

9301B

Operating Manual

Genelec 9301B

Multichannel AES/EBU Interface

GENELEC®



Genelec 9301B Multichannel AES/EBU Interface



Introduction

Congratulations and thank you for purchasing the Genelec 9301B multichannel AES/EBU interface.

This manual addresses the setting up and use of the Genelec 9301B multichannel AES/EBU interface intended for use with 7300 Series subwoofers.

73xx Smart Active Monitoring (SAM) subwoofers have one AES/EBU digital input. The 9301B expands that digital audio connectivity to 16 channels, to create, for example, a 9.1.6 configuration including the additional low frequency effects (LFE) channel.

Genelec's energy-saving Intelligent Signal Sensing (ISS) function automatically puts the 9301B into a power-save state when no AES/EBU input signal is present. The waiting time before activation can be configured using Genelec Loudspeaker Manager (GLM) software. When ISS is on your monitoring system will remain ready for action and the 9301B will consume less than 0.5 watt of power. The interface will wake up and switch to normal operating mode when it senses an AES/EBU input signal.

This 9301B is supplied with:

- Mains cable
- 5 m GLM network cable
- Operating manual

Installation

We strongly recommend switching off/disconnecting mains power from all system devices before connecting signal cables.

Connections

The mains input supports a wide voltage range (100-240 VAC, 50-60 Hz). If the mains power is provided by a generator, inverter or a low-quality UPS device, we recommend using a harmonic filter to reduce the unwanted harmonic distortion.

The digital audio inputs for AES/EBU digital audio both use DB25 connectors. If the LFE channel is in use, the interface channel and subframe carrying the LFE signal is assigned by the user in GLM.

The digital audio output for the monitors uses one DB25 connector to deliver 16 channels of AES/EBU format audio. The output signals are bit-to-bit copies of the digital input signals, so the outputs retain the original signal quality without modification. When used, the LFE signal is output through the same DB25 connector, meaning that the LFE channel content is available for any device connected to this output.

The digital audio output for the subwoofer is a single male XLR connector, which uses an AES/EBU cable to carry the sum of all the main channel inputs over one AES/EBU subframe and the LFE channel, if used, over the other AES/EBU subframe. A GLM Kit and Genelec Loudspeaker Manager (GLM)

software is required in order to use the 9301B with 7300 Series subwoofers.

The AES/EBU output on 7300 Series subwoofers enables the daisy-chaining of additional SAM subwoofers to increase the capacity of the system's low frequency acoustic output (SPL). To make this possible, GLM software will align the playback of the complete subwoofer system with the rest of the monitoring system.

The 9301B includes two GLM Network connectors for management using Genelec Loudspeaker Manager (GLM) software.

Input cabling

Digital Audio Workstations and other professional digital audio sources frequently offer DB25 connectors using AES59 standard compatible pinouts for digital audio. These typically feature four inputs and four outputs, delivering up to 8 channels of digital audio in and 8 channels of digital out. This pinout is also known as the Tascam digital audio pinout. The AES59 standard also offers a configuration to deliver 16 channels of digital audio in one direction, used in the output DB25 connector of 9301B (see 'Output cabling' section below).

The 9301B uses two AES59 compatible DB25 connectors for input, each receiving up to 8 channels of digital audio from the digital audio source, typically connected with DB25-to-DB25 cables connecting the audio source digital outputs to the receiving device

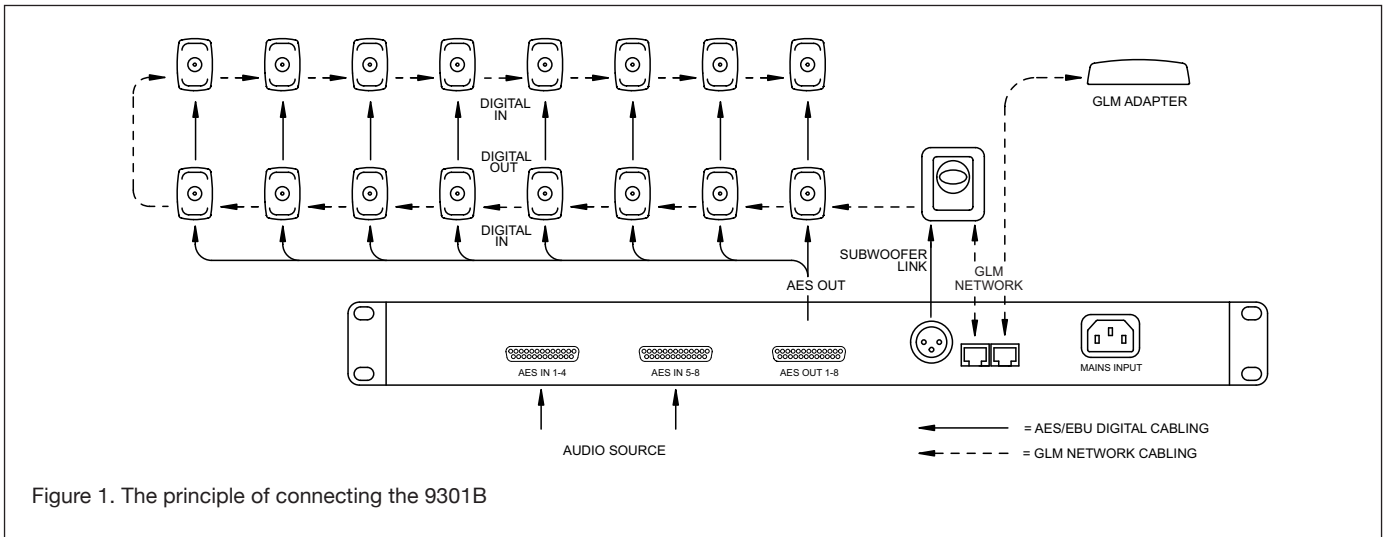

Figure 1. The principle of connecting the 9301B

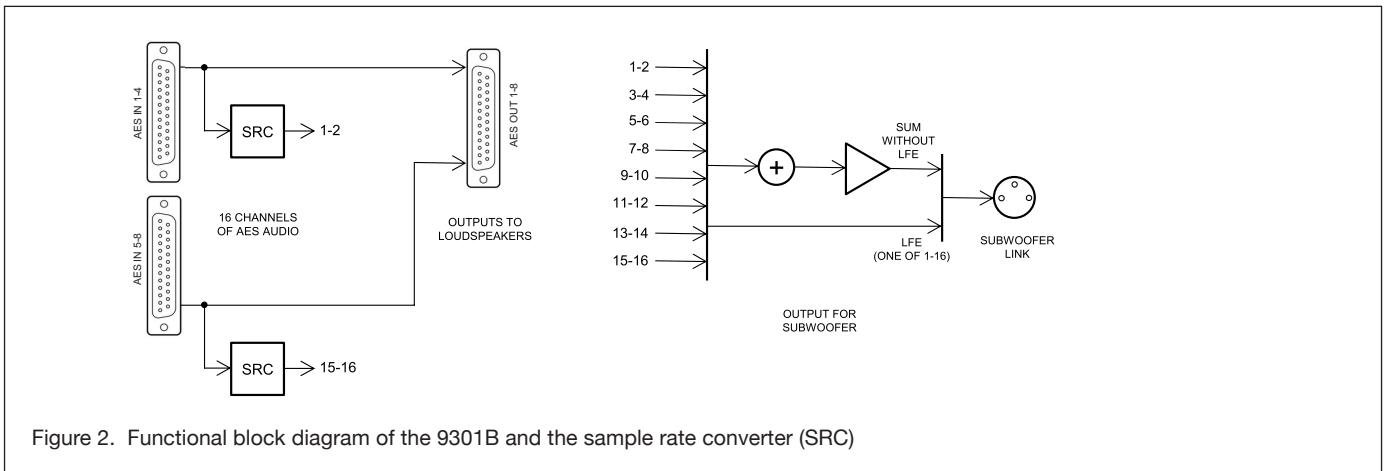

Figure 2. Functional block diagram of the 9301B and the sample rate converter (SRC)

digital inputs (see Fig. 3). Please check for this specifically when purchasing the cable.

If you'd also like to access the incoming digital audio lines on your audio source's DB25 connectors, a combination of two break-out cables offering XLR connectors can be used between your audio source and each 9301B DB25 input. This makes the audio source device's DB25 connectors available for incoming connections and this is also a safe choice as you will always have the possibility to connect specific outputs at the digital audio source to the digital audio inputs in 9301B. For example, Avid cable type DigiSnake DB25-XLR M+F AES/EBU is suitable for this.

Output cabling

The AES59 standard offers a configuration to deliver 16 channels of digital audio in one direction. This is in the output DB25 connector of 9301B. The audio output

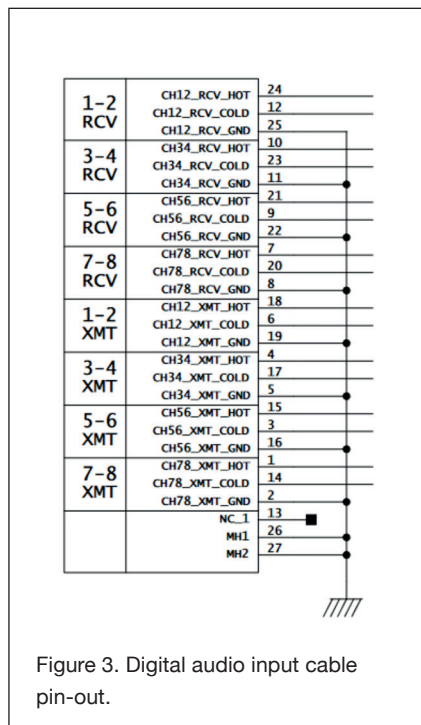

Figure 3. Digital audio input cable pin-out.

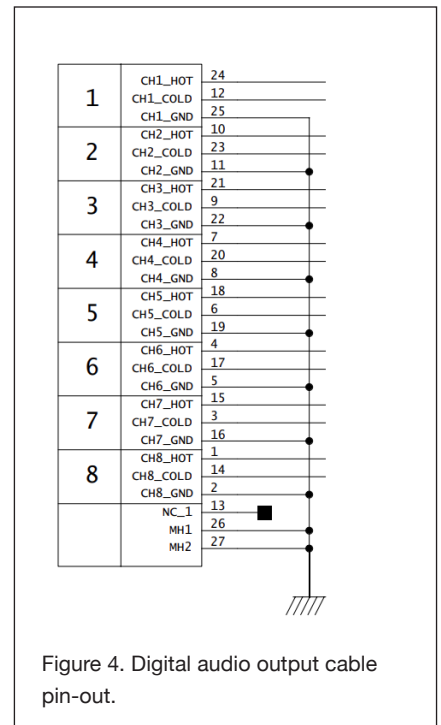

Figure 4. Digital audio output cable pin-out.

in 9301B is intended for connections to monitors. The recommended cable for this connection is an 8 x XLR male fan-out cable with AES59 pin-out, also known as the Tascam analogue pin-out. For example an Avid cable type DB25-XLRM DigiSnake can be used. Typically AES/EBU XLR-to-XLR cables are required to extend the signal onwards to the monitors.

Connector pinouts

The input connector pinouts of the 9301B's two DB25 audio input connectors follow the AES59 standard compatible pinout shown in Figure 3. This features four inputs and four outputs, delivering 8 channels of digital audio in and 8 channels of digital out. This pinout is also known as the Tascam digital audio pinout.

The AES59 standard offers a configuration to deliver 16 channels of digital audio in one direction. The output connector pin-out of the 9301B's single DB25 out is shown below. This pinout is compatible with the AES59 standard. This pinout is also known as the Tascam analogue output pinout. We strongly recommend that a high-quality AES/EBU digital audio cable is used.

Controls and Adjustments

The 9301B's front panel features a mains power switch with power-on light and eight active-connection indicator lights for AES/EBU inputs, each carrying two channels of audio.

The 9301B is completely set up using Genelec Loudspeaker Manager (GLM™) software. Please refer to the 'Use With GLM Management Network' section below for details.

While editing the 9301B settings in GLM, the interface's power-on light will blink continuously. A lit input light indicates a valid AES/EBU input. If an input light is off, there is an AES/EBU data issue or there is no valid AES/EBU input. See Table 1 for a list of indicator lights and their functions.

Use With GLM™ Management Network

The 9301B is set up using Genelec Loudspeaker Manager GLM™ software, using GLM's Management Network. More information about the GLM is available in the SAM System Operating Manual.

Indicator	Colour, indication	Meaning
Power switch	Solid green	Power on, normal operation
	Blinking green	GLM is adjusting 9301B
	Green blink every 10 s	9301B in power save mode
	No light	No power, power off
Input signal indicator	Solid green	Valid digital audio is detected and received
	No light	Valid input is not detected

Table 1. Front panel indicator light functions

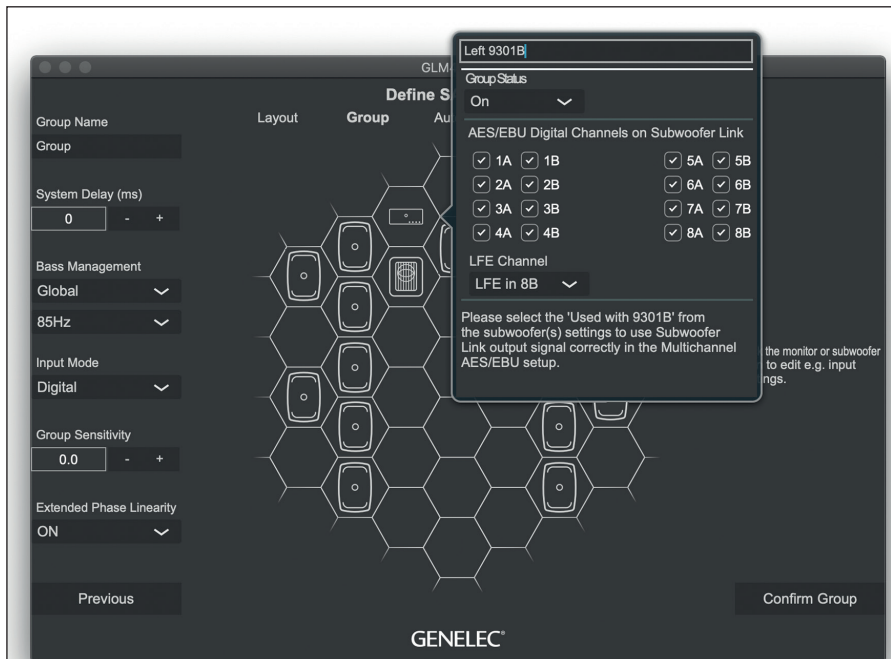

Figure 5. 9301B setup panel in GLM software.

System configuration

Setup is simple and consists of the following steps:

- Connect digital audio inputs 'AES IN 1-4' and 'AES IN 5-8'.
- Connect 'AES OUT 1-8' to a fan-out cable and continue with XLR-to-XLR cables to each monitor. Please use cables intended for carrying AES/EBU digital audio. We strongly discourage the use of standard analogue microphone cables as this may reduce system performance.
- Connect the 'SUBWOOFER LINK' output to the 'DIGITAL IN' connector on a Genelec 7300 Series subwoofer.
- Connect CAT 5 (RJ45) cables between the 9301B, every monitor and subwoofer.

Finally, connect to the GLM Adapter device (see Figure 1). The connection order of the other devices is not important. Connect the GLM Adapter device to your computer via USB.

- Install and run Genelec Loudspeaker Manager (GLM) software.

All devices appear in GLM software monitor stack. Move devices from the monitor stack onto GLM honeycomb grid, including the 9301B. You may want to drag and drop 9301B close to the subwoofer connected to it (see Figure 5).

When using multiple 9301Bs, you can identify an 9301B by clicking the 9301B icon in GLM, causing the associated 9301B device front panel power button light to blink.

Setting up a 9301B in GLM:

- Select the 'Input Signal Type' for the monitor Group to be 'AES/EBU Digital'. Then 9301B devices become active in the group. Set the 'AES/EBU Digital Input Mode' for all the connected 7300 Series subwoofers to 'Multichannel'.
- Select the AES/EBU inputs to enable them.
- In the 'LFE Channel' drop-down, select the AES input and subframe that carries the LFE channel audio.
- Select the '+10 dB' setting in the subwoofer configuration if the LFE channel audio requires a 10 dB boost relative to the main audio channels.

When all 9301B units in the system are set to 'Group Off' state, the 'AES/EBU Digital Input Mode' in all 7300 series subwoofers switch the AES/EBU digital stereo audio input to a standard stereo audio input.

Acoustic calibration

To acoustically calibrate your setup, fix the measurement microphone included with your GLM Kit onto a microphone stand so that the microphone points upwards, then place the microphone at the listening position with the top positioned at the listener's ear height.

Follow the steps in GLM software to calibrate your entire system. The calibration process starts after you create a new group preset using 'File' | 'New' menu item. An existing group preset can be calibrated by selecting the 'Group Preset' | 'Calibrate' menu item.

If you wish to disconnect the computer after calibration, save GLM calibration onto monitors, subwoofers and 9301B interfaces in your system. The settings can be stored using GLM software menu item 'Store' | 'Store the Current Group Settings'. Note that monitors and subwoofers have a switch that enables stored settings. This switch must be set to ON for operating the system with the stored settings. After removing the GLM network cable and powering the 9301B and monitors off and on again enables the stored settings. We strongly recommend using GLM software and keeping the GLM network connected for the full flexibility of the monitoring system.

Returning to factory settings

GLM settings stored in a 9301B can be erased by keeping the power switch depressed for more than 10 seconds before releasing it again. This returns the 9301B to its factory settings. After this, GLM software should be used to reconfigure the 9301B.

Operating Environment

The 9301B is designed for indoor use only, and the permissible ambient room temperature is 15-35 degrees Celsius (59-95°F) with a relative humidity of 20% to 80% (noncondensing). If the 9301B has been stored or transported in a cool environment before entering a warm room, please wait between 60 minutes before unpacking it, as this will prevent harmful condensation. Sufficient cooling must be ensured to keep the 9301B within optimal operating temperatures. No minimum clearance for ventilation is needed around the interface.

Maintenance

There are no user serviceable parts inside the 9301B. Maintenance or repair must only be performed by Genelec certified service personnel.

Guarantee

Genelec guarantees the 9301B for two years against manufacturing faults or defects that alter performance. Refer to the reseller for full sales and guarantee terms.

Safety Considerations

The 9301B has been designed in accordance with international safety standards. To ensure safe operation, the following warnings and precautions must be observed:

- Servicing and adjustment must only be performed by Genelec certified service personnel.
- The enclosure must not be opened.
- Do not use this product with a mains cable or mains outlet without a protective earth (potential-equalising) connection, as doing so may result in personal injury.
- To prevent fire or electric shock, never expose the unit to water or moisture.
- Do not place objects filled with liquid, such as vases, on or near the 9301B.
- The 9301B is never completely disconnected from mains power unless the mains cable is removed from the device or the mains outlet.

Compliance to FCC Rules

This device complies with part 15 of the FCC Rules. Operation is subject to both of the following two conditions:

- This device may not cause harmful interference.
- This device must accept any interference received, including interference that may cause undesired operation.

Note: This equipment has been tested and found to comply with the limits for a Class B digital device, pursuant to part 15 of the FCC Rules. These limits are designed to provide reasonable protection against harmful interference in a residential installation. This equipment generates, uses, and can radiate radio frequency energy and, if not installed and used in accordance with the instructions, may cause harmful interference to radio communications. There is no guarantee that interference will not occur in a particular installation. If this equipment does cause harmful interference to radio or television reception, which can be determined by turning the equipment off and on, the user is encouraged to try and correct the interference by one or more of the following measures:

- Reorient or relocate the receiving antenna.
- Increase the separation between the equipment and receiver.
- Connect the equipment into an outlet on a circuit different from that to which the receiver is connected.
- Consult the dealer or an experienced radio/TV technician for help.

Modifications not expressly approved by the manufacturer can void the user's authority to operate the equipment under FCC rules.

SPECIFICATIONS	
Weight	2 kg (4.4 lbs)
Dimensions: Height Width Depth	43 mm (1 3/4 in) 483 mm (19 in) 105 mm (4 1/8 in)
Mains voltage	100...240 VAC (50...60 Hz)
Mains tolerance	+/- 10 %
Power consumption ISS power saving mode Idle Full operation	< 0.5 W 2.5 W 4 W
Digital audio input connectors	2 x DB25 (Tascam AES59-2012)
Digital audio input impedance	110 Ohm
Digital audio output connectors	1 x DB25 (Tascam AES59-2012) & 1 x XLR subwoofer out
Digital audio format	AES/EBU (AES3)
Digital audio word length	Minimum 16 bits, maximum 24 bits. Fixed point, AES/EBU format
Digital audio sample rate	Minimum 32 kHz, maximum 192 kHz. Supports single-wire AES/EBU audio, does not support dual wire AES/EBU audio

Genelec 9301B Multichannel AES/EBU Interface

GENELEC®

International enquiries:

Genelec, Olvitie 5
FIN-74100, Iisalmi, Finland
Phone +358 17 83881
Fax +358 17 812 267
Email genelec@genelec.com

In the U.S. please contact:

Genelec, Inc., 7 Tech Circle
Natick, MA 01760, USA
Phone +1 508 652 0900
Fax +1 508 652 0909
Email genelec.usa@genelec.com

In China please contact:

Beijing Genelec Audio Co.Ltd
Room 101, Building B33,
Universal Business Park,
No.10 Jiuxianqiao Road,
Chaoyang District,
100015 Beijing, China
Phone +86 (10) 5823 2014
+86 400 700 1978
Email genelec.china@genelec.com

In Japan, please contact:

Genelec Japan Inc.
2-22-21 Akasaka, Minato-ku
07-0052, Tokyo
Phone +81-3-6441-0591
genelec.japan@genelec.com
Email genelec.japan@genelec.com

In Sweden please contact

Genelec Sverige
Tureholmsvägen 12
125 35 Älvsjö
Sweden
Phone +46 8 449 5220
Email sweden@genelec.com