

Louisiana-Pacific Corporation
Design No. LPC/RB 120-05
Rim Board
LP® SolidStart® Rim Board
ASTM E119
Rating: 2 Hour

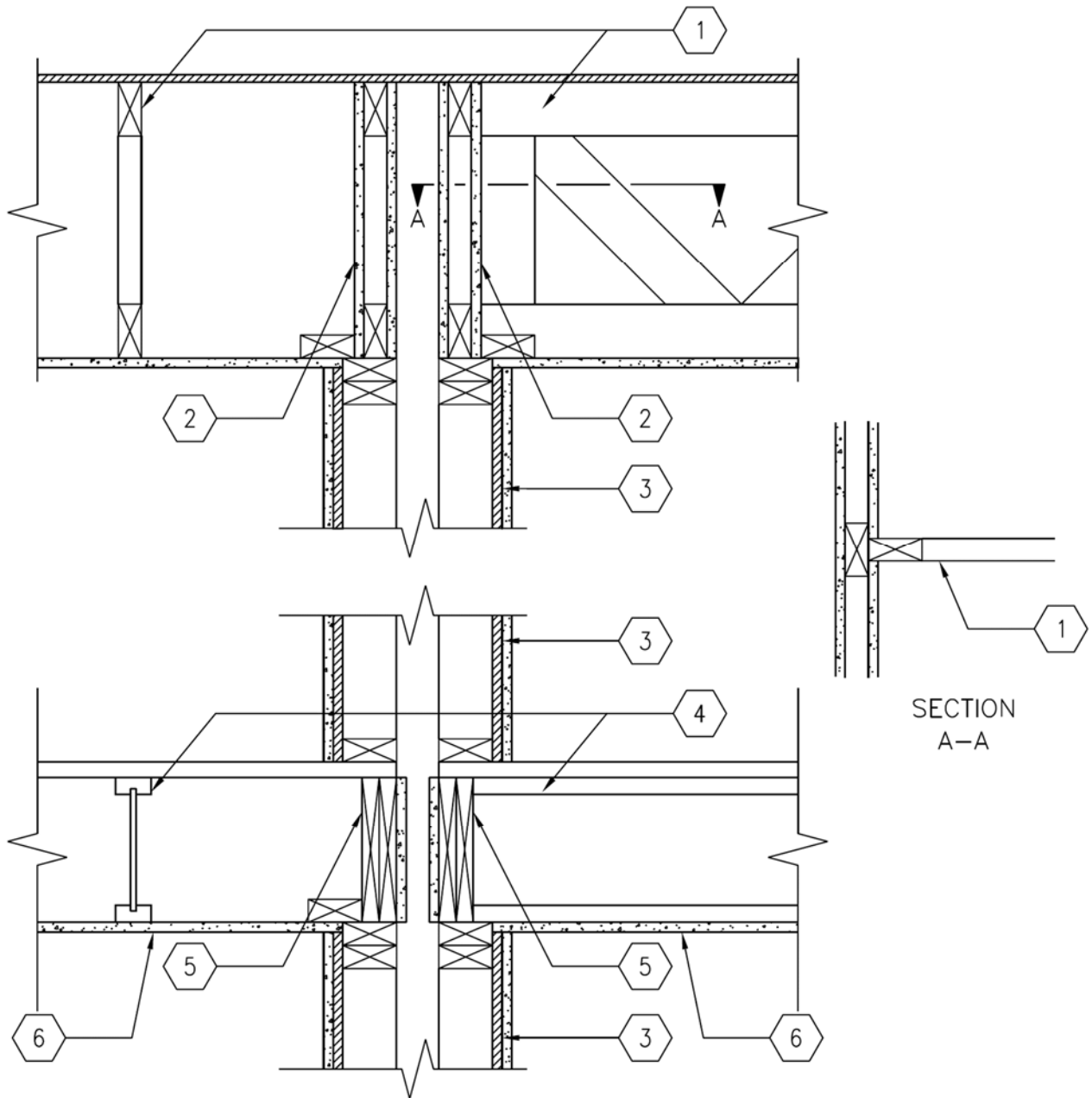

The assembly is based on a residual rim board thickness of 1 in.



- 1. ROOF/CEILING:** Roof/ceiling assembly constructed with trusses or joists per the project specifications. Trusses or joists can be parallel or perpendicular to the 2 hr fire-resistance rated wall assembly (Item 3).

As illustrated in Section A-A view, a continuous vertical web is allowed at each truss with min. 1 in. overlap for interior gypsum on each side of truss. Gypsum board to be continuous on interior or cut to fit tight between trusses with max. 1/16 in. gap.

- 2. 2-HR FIRE RATED CONTINUITY TO ROOF DECK:** Maintain the 2 hr fire-resistance rated separation by installing a truss or joist parallel with the 2 hr fire-resistance rated wall on each of the two top plates. For non-load bearing truss or joist apply 1 layer (continuous) of 5/8 in. thick Type X gypsum board on each side of the truss or joist (shown) using 1-7/8 in. long, 8d cement coated nails spaced 8 in. on center (oc). For load bearing truss or joist, apply 2 layers (continuous) of 5/8 in. thick Type X gypsum board on each side of the truss or joist (not shown) using 1-7/8 in. long, 8d cement coated nails spaced 12 in. oc for the first layer and 2-3/8 in. long, 8d cement coated nails spaced 8 in. oc for the second (outer) layer. Joint treatment not required at square edges.
- 3. WALL ASSEMBLY:** Intertek Design No. BTC/WPPS 120-2 or UL Design No. U350 Configuration A (shown) and Configuration B, 2 hr fire-resistance rated wall assembly, continuous from floor to ceiling.
- 4. FLOOR/CEILING ASSEMBLY:** Floor/ceiling assembly constructed with trusses or joists per the project specifications. Trusses or joists can

be parallel or perpendicular to the 2 hr fire-resistance rated wall assembly (Item 3). For parallel framing, provide intermediate blocking at max. 4 ft. oc.

- 5. RIMBOARD:** Solid LSL Rimboard

CERTIFIED PRODUCT: Louisiana- Pacific Corporation, LP® SolidStart® LSL.

Alternatively, other composite lumber conforming to all pertinent provisions of ASTM D5456 maybe used and must maintain minimum requirements specified below.

Maintain the 2 hr fire-resistance rating continuity through the floor/ceiling assembly (Item 4) with option A or B.

- A. One min. 2-1/4 in. thick continuous solid LSL. Apply 1 layer (continuous) of min. 5/8-in. thick Type X gypsum board on the unoccupied side of the rim board using 1-7/8 in. long, 8d cement coated nails spaced 8 in. oc.
- B. Two min. 1-1/8 in. thick, continuous LSL. Apply 1 layer (continuous) of min. 5/8 in. thick Type X gypsum board on the unoccupied side of the rim board using 1-7/8 in. long, 8d cement coated nails spaced 8 in. oc.

- 6. GYPSUM BOARD:** Min. 5/8 in. thick Type X gypsum board required on ceiling of floor/ceiling assembly (Item 4).

Consult the listing report on the Directory of Building Products (<https://bpdirectory.intertek.com>) for the edition of the standard(s) evaluated.