

MULTISTRAND STAY CABLE SYSTEMS





**WE MAKE INFRASTRUCTURE
SAFER, STRONGER, AND SMARTER.**



Contents

History	4	Full Size Testing	30
DYNA Grip® Stay Cable System	6	Standard Fatigue and Tensile Testing	30
High Fatigue Performance	6	Fatigue and Tensile Testing with higher load level and additional Transverse Deflection	30
Durability and high-quality Corrosion Protection	7	Fatigue and Tensile Testing with additional Transverse Deflection (Setra)	31
Replaceability of Strands	7	Increased Load Cycle Testing – 10 Million Cycles	31
Fast Construction Cycles	7	Monostrand Fatigue Testing under Reversed Cyclic Flexural Loading	32
Drawing	8	Leak Tightness Test	33
DYNA Grip® Stay Cable System – Optional Solutions	10	Cable Installation	34
Vandalism Protection & Guide Deviator	10	Stressing	36
Cable Hardening	11	ConTen Stressing	36
Fire Protection	12	DYNA Force® Elasto-Magnetic Sensor	38
Cable De-icing	13	Functional Principle	38
Clevis Anchorage	14	System Components	38
DYNA® Link Anchor Box System	16	System Advantages in Comparison to other Measuring Systems	38
Advantages to Conventional Pylon Solutions	16	Quality Assurance	39
Advantages in Comparison to Conventional Saddle Solutions	17	Practical Applications	39
Stay Cable Installation	19	Cable Inspection	40
Saddle Solution	20	Visual Inspection	40
Saddle with Individual Tubes	20	Vibration Measurement	41
Fully Grouted Solutions	22	Magnetic Flux Leakage Inspection	41
DYNA Bond® Anchorage	22	References	42
Saddle with Anchor Groove and Pin	23	Stay Cable References	42
Strand and Wedge	24	Extradosed Bridges	46
Epoxy Coated Strands	24	Arch Bridges	48
Outer Stay Pipe	25	Special Applications	49
Cable Damping	26		
Excitation Causes	27		
Damper Design	28		

History

ABOUT US

DYWIDAG-Systems International (DSI) is a globally leading system supplier of innovative technologies for the construction industry.

TRADITION

The long tradition of DSI reaches back as far as 1865 – the founding year of the German construction firm, Dyckerhoff & Widmann AG (DYWIDAG). DSI was founded in the year 1979 to market DYWIDAG Systems and technical know-how around the world and to develop innovative systems resulting from its own R&D activities.

DSI TECHNOLOGY

In more than 50 countries and at 15 regional manufacturing sites, DSI Construction develops, produces and supplies high quality systems such as DYWIDAG Post-Tensioning Systems, Geotechnical Systems and "Concrete Accessories". In accordance with our slogan "*Local Presence – Global Competence*", more than 1,400 specialized and experienced DSI employees ensure that DSI's technologies and know-how are available around the world. DSI offers quality on all levels – quality that is characterized by creativity, reliability and profitability.

COMPREHENSIVE SERVICES

Our comprehensive services include the conception, design, planning and installation of its systems as well as quality management and on site supervision.

RESEARCH & DEVELOPMENT

Continued investments in Research & Development and the resulting patent applications sustainably strengthen the know-how available within the DSI Construction Group. By offering innovative solutions in accordance with superior quality standards, we fulfill the constantly changing requirements of our target markets. It is our declared aim to always be one step ahead.

CLIENT ORIENTATION

The needs and requirements of clients and business partners are always of paramount importance. Our company is characterized by reliability, trust and cooperation based on partnership. We offer our clients the advantages of an international system supplier with a product range that is tailored to suit individual requirements.

CERTIFICATIONS & INTERNATIONAL ORGANIZATIONS

International organizations, trade associations and standards committees are becoming more important in times in which products and services seem more and more interchangeable. Organizations and trade associations are cross-linked on a global basis and promote the exchange of technology and know-how across borders. We are an active member in many International Organizations to drive technical developments. In April 2016, DSI received a general technical approval for DYNA Grip® Multistrand Stay Cables for Stay Cable Bridges. It is the world's first approval to regulate Multistrand Stay Cable Systems.



1994

Odawara Blueway Bridge, Odawara, Japan

MILESTONES

DYWIDAG Post-Tensioning Systems and Stay Cable Systems are world renowned for reliability and performance; they are perfectly suitable for all applications in post-tensioned construction. They embrace the whole spectrum from bridge construction and buildings to civil applications – both above and below ground.

In addition to traditional post-tensioning systems with bars, DSI offers a complete product line in strand post-tensioning (bonded, unbonded and external) as well as stay-cable systems to fulfill the changing requirements in the industry today and tomorrow.

As a further development of the first cable stayed bridges in the 60's and 70's of the last century, new systems were introduced into the market considering new materials and increasing requirements on modern infrastructures.

The application of DSI's stay cable system for the Odawara Blueway Bridge (Japan) in 1994 – which is known as the first extradosed bridge in the world – as well as for Kap Shui Mun Bridge (Hongkong) in 1995 are two outstanding milestones in DSI's stay cable history.

Established in 2000 and still used today, the DYNA Grip® System already took into account the requirements for modern cable systems at the turn of the millennium. Our stay cable systems have always combined the highest safety and reliability standards with excellent economical efficiency in their research and development.

Dependable corrosion protection methods, damper design, fire protection, vibration measurements and the recently developed DYNA Force® monitoring system significantly contribute to the longevity of modern construction and cable hardening for mitigating multiple threat scenarios (vandalism, fire, blasts etc.).



2000

Victoria Bridge, Rosario, Argentina
First DYNA Grip® Stay Cable Bridge



1972

2. Main Bridge, Hoechst Chemicals,
Frankfurt, Germany



1995

Kap Shui Mun Bridge, Hongkong, China
DYNA Bond® Stay Cable Bridge with 176 cables

DYNA Grip® Stay Cable System

The DYNA Grip® Stressing Anchorage consists of an anchor block in which the strands are anchored by high fatigue 3 part-wedges. A ring nut is threaded onto the anchor block to transmit the cable force into the structure via the bearing plate. A steel pipe which incorporates bending and sealing provisions for the strands is part of the anchor block. A non-adjustable anchorage with the same provisions for bending and sealing of the strands can be placed at the dead-end side.

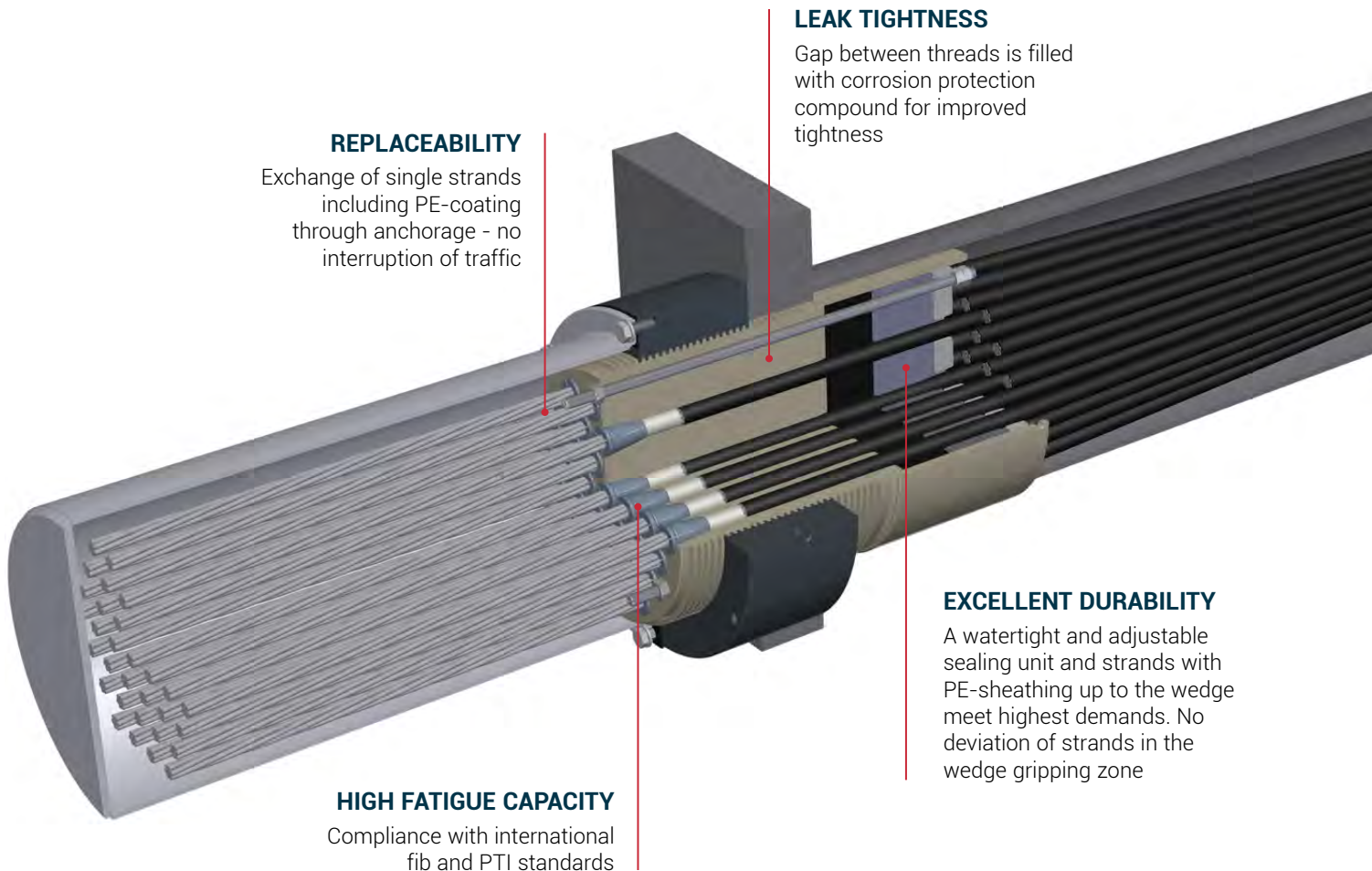

REPLACEABILITY

Exchange of single strands including PE-coating through anchorage - no interruption of traffic

LEAK TIGHTNESS

Gap between threads is filled with corrosion protection compound for improved tightness

EXCELLENT DURABILITY

A watertight and adjustable sealing unit and strands with PE-sheathing up to the wedge meet highest demands. No deviation of strands in the wedge gripping zone

HIGH FATIGUE CAPACITY

Compliance with international fib and PTI standards

HIGH FATIGUE PERFORMANCE

The system has proven its excellent performance and fulfills the requirements of *fib* Bulletin 30 as well as PTI & Setra requirements for fatigue and tensile strength:

- Multiple full size tests on cable sizes from 7 to 156 strands
- Tests on single strands under reversed cyclic flexural loading with 45% and 60% GUTS, 2 million load cycles with anchorages inclined by 3.0° and additional angular deviation between $\pm 10\text{mrad}$ and $\pm 35\text{mrad}$
- The system has been successfully tested in standard tests with a stress range of up to 200MPa at an upper stress limit of 45% GUTS and at 2 million load cycles with anchorages inclined by 0.6°. In addition, full size tests have been performed successfully with an upper load of up to 60% GUTS, up to 10 million load cycles and a stress range of up to 250MPa
- The leak tightness of the anchorage area has been demonstrated for the complete system and even meets stringent fib and Setra requirements with:
 - Up to 3m water head
 - Several load cycles in the longitudinal and transverse direction
 - Temperature cycling 20–70°C

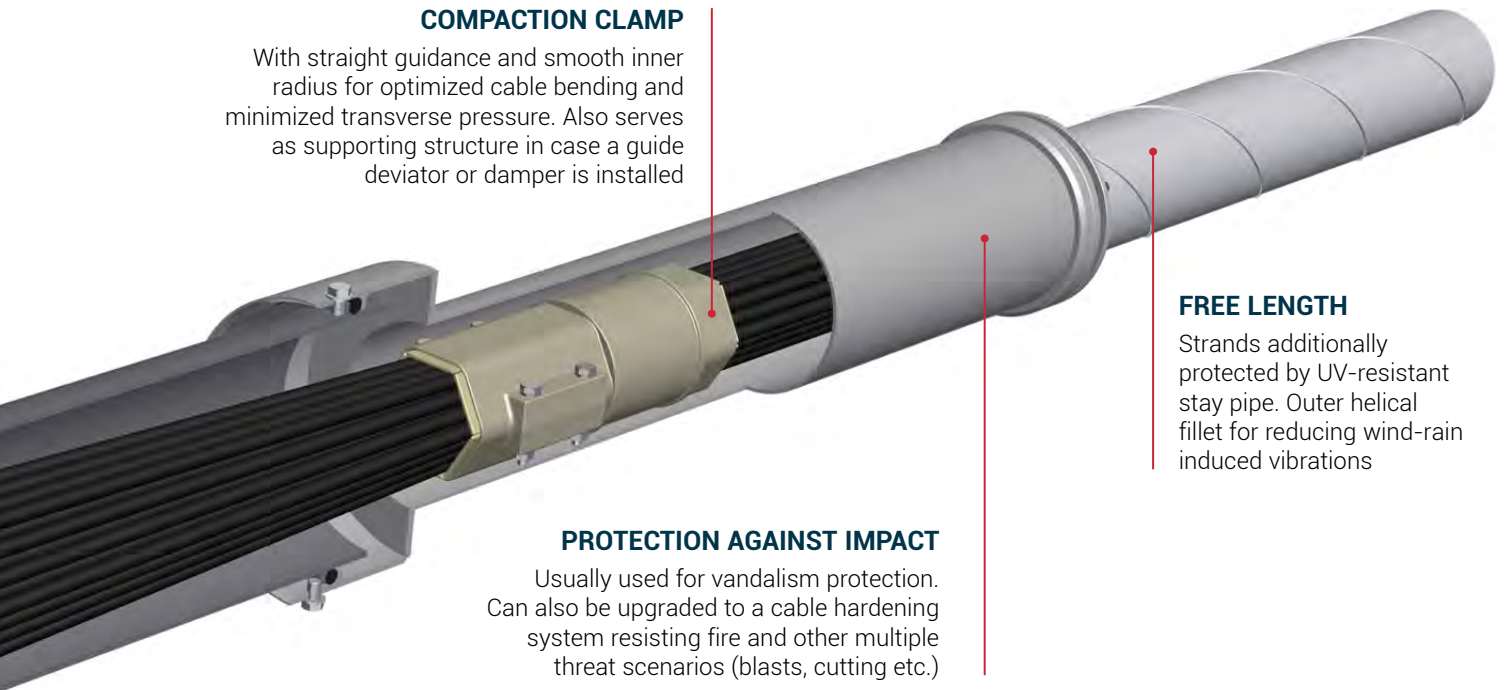

COMPACTION CLAMP

With straight guidance and smooth inner radius for optimized cable bending and minimized transverse pressure. Also serves as supporting structure in case a guide deviator or damper is installed

FREE LENGTH

Strands additionally protected by UV-resistant stay pipe. Outer helical fillet for reducing wind-rain induced vibrations

PROTECTION AGAINST IMPACT

Usually used for vandalism protection. Can also be upgraded to a cable hardening system resisting fire and other multiple threat scenarios (blasts, cutting etc.)

DURABILITY AND HIGH-QUALITY CORROSION PROTECTION

Strands are guided into the anchorage by an elaborate system that ensures both leak tightness and smooth deviation:

- Compressible sealing plates ensure water and even vacuum tightness
- The correct function can be checked and even adjusted during inspection
- Bending stresses are minimized by a filter that arranges a straight-line entering into the wedge gripping area
- A cap including filler material for the protection of individual strands is placed in front
- Corrosion protection resists corrosivity class C5 in accordance with ISO 12944

The anchorages have been designed for threading the strands including their PE-sheathing through the anchorage:

- Dismantling of the strand's PE-sheathing is minimized to what is absolutely necessary.
- The factory applied corrosion protection of the strands continues directly up to the wedges.
- Significant reduction of the length of anchorage area where interstices are filled with corrosion protection compound. Both high durability and cost savings in terms of additional filling material are guaranteed.

Free length:

- The strands are protected by a multi-layer system of galvanized wires and are tightly sheathed by HDPE. A wax filling is used for the interstices in between.
- An outer stay pipe made of UV-resistant HDPE additionally protects the strands and minimizes rain-wind induced vibrations with an outer helical fillet that provides a low drag coefficient.

REPLACEABILITY OF STRANDS

As the PE-coating is pulled directly through the anchorage, an exchange of strands is possible at any time during the service life of the bridge without the need for renewing or replacing any

- Strand exchange is performed directly at the anchorages
- There is no need for moving the cable's outer stay pipe for accessing the strand bundle either at the deck or outside the pylon – no disruptions to traffic.

FAST CONSTRUCTION CYCLES

- Lightweight equipment for strand installation and stressing operations is provided by DSI.
- A compaction clamp, installed after stressing on the strand bundle, keeps the strand in a compact hexagonal pattern.
- Non-protruding recess pipes at the pylon - no additional formwork adjustment is required.
- No exact dismantling of the strand's outer sheathing is necessary. In case of stressing actions that are additionally required, the strand sheathing is compressed by small tubes in front of the wedges while the strand is pulled through and elongated by the jack.
- The use of tower cranes or other lifting equipment can be limited to a minimum.

DRAWING

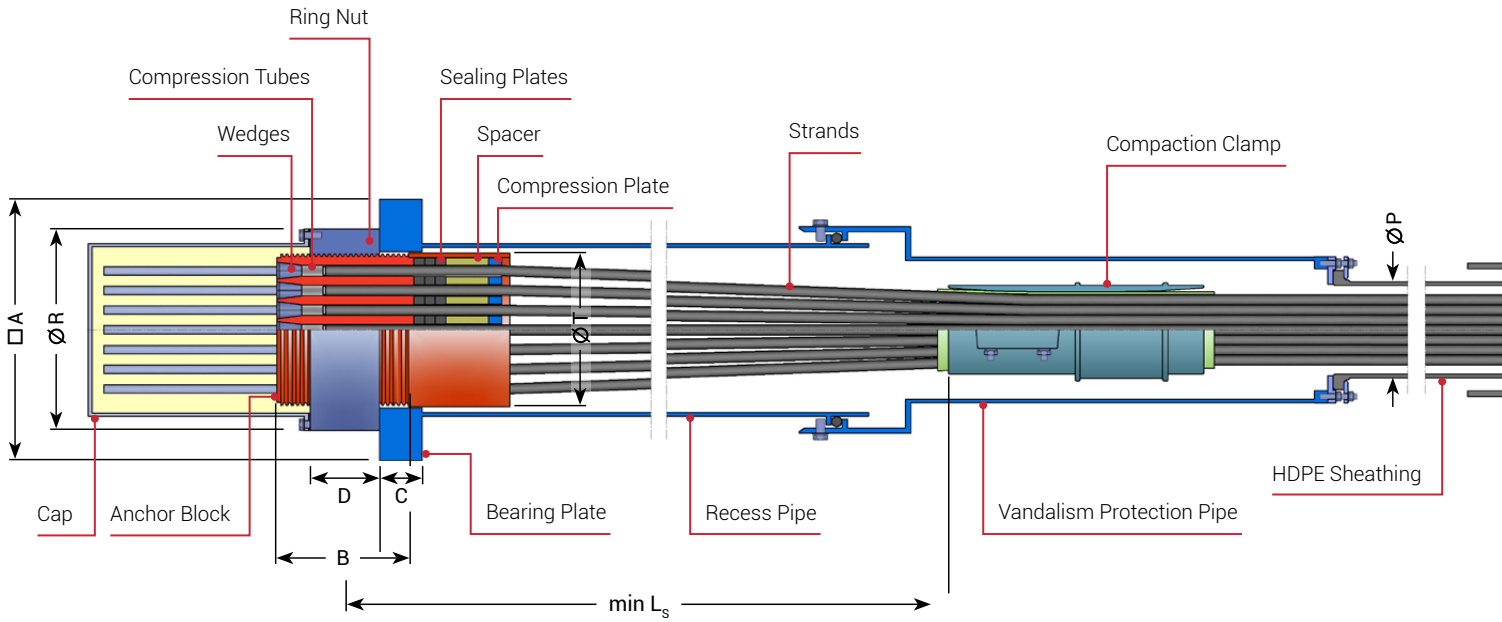

DYNA GRIP® ANCHORAGE – TECHNICAL DATA

(forces calculated with strands 0.62” St 1660/1860)

Cable type *	DG-P4	DG-P7	DG-P12	DG-P19	DG-P31
No. of strands	4	7	12	19	31

Forces [kN] **	DG-P4	DG-P7	DG-P12	DG-P19	DG-P31
Ultimate load at 100% GUTS	1,116	1,953	3,348	5,301	8,649
Service load at 50% GUTS for stay cables	558	977	1,674	2,651	4,325
Service load at 60% GUTS for extradosed tendons	670	1,172	2,009	3,181	5,189

Dimensions [mm]		DG-P4	DG-P7	DG-P12	DG-P19	DG-P31
Bearing plate ***	□ A	190	250	300	370	460
Bearing plate ***	C	20	25	30	35	40
Bearing plate opening	∅ T	112	145	183	219	267
Thread ****	B	160	170	200	220	230
Ring nut	D	50	50	90	110	120
Ring nut	∅ R	150	210	244	287	350
Dead anchor	E	50	90	120	120	135
Dead anchor	∅ F	150	190	215	261	324
Distance of compaction clamp, stressing end	min L _s	520	650	880	1,080	1,350
Distance of compaction clamp, dead end	min L _d	430	540	770	970	1,240
HDPE sheathing	∅ P	63	90	110	125	160
HDPE transition tube	∅ S	110	140	200	225	250

* larger sizes on special request

** local design guidelines must be taken into account

*** dimensions correspond to concrete strength ≥ 35MPa (cylinder) at 45% GUTS according to PTI anchorage zone design

**** standard length, changeable on special request

Subject to modification

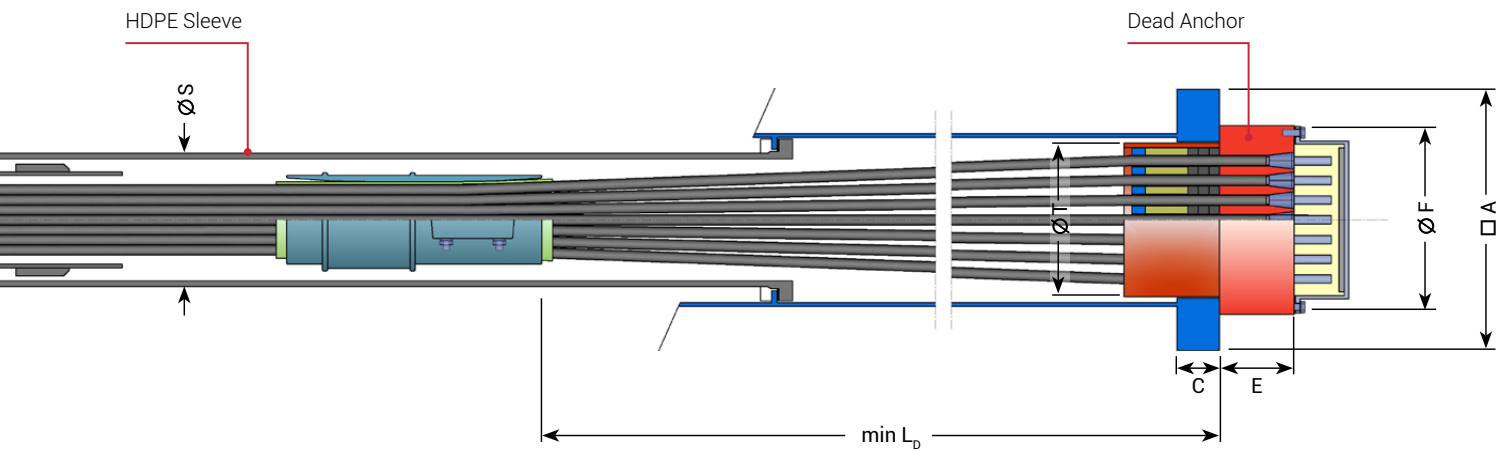

DG-P37	DG-P43	DG-P55	DG-P61	DG-P73	DG-P85	DG-P91	DG-P109	DG-P127
37	43	55	61	73	85	91	109	127
10,323	11,997	15,345	17,019	20,367	23,715	25,389	30,411	35,433
5,162	5,999	7,673	8,510	10,184	11,858	12,695	15,206	17,717
6,194	7,198	9,207	10,211	12,220	14,229	15,233	18,247	21,260
500	600	600	640	715	780	780	855	910
45	55	60	65	70	75	80	85	90
293	329	341	371	403	429	455	479	531
240	250	270	275	290	300	310	340	350
130	140	160	165	180	190	200	230	240
378	420	440	480	536	554	600	636	700
135	150	170	170	185	190	195	210	220
354	398	420	450	490	522	550	586	645
1,500	1,690	1,750	1,920	2,070	2,170	2,340	3,020	3,390
1,390	1,580	1,640	1,810	1,960	2,050	2,230	2,910	3,280
180	180	200	225	250	280	280	315	315
250	315	315	315	355	355	355	450	450

DYNA Grip® Stay Cable System - Optional Solutions

VANDALISM PROTECTION & GUIDE DEVIATOR

The DYNA Grip® Stay Cable System can be easily adjusted or upgraded if required:

- The length of the vandalism protection pipe can be adjusted to project specific requirements to achieve any requested height above the bridge deck level. It can be made of 2 long parts or customized for retrofitting purposes.
- On special request, guide deviators can be provided both at the deck and at the pylon to:
 - reduce cable bending at the anchorages
 - decrease cable vibrations
- DSI has patented (EP2729621 B1; US9009899 B2) an eccentric flange connection between the recess pipe and the housing for the guide deviator. The eccentric flange connection ensures that eccentricities caused by wrong installation angles of the recess pipe can be compensated.



CABLE HARDENING

DSI's cable hardening system has been developed to protect the stay cables effectively against multiple threat scenarios for all stay cable sizes.

- Any kind of mitigation level in terms of specific customized threat scenarios and the required strength of the protection system can be taken into consideration.
- Highly effective protection material can be easily adjusted to requirements and threats
- Numerical simulation and physical testing is carried out using expertise from Fraunhofer Institute for High Speed Dynamics (Ernst-Mach-Institute)
- Validation of different scenarios with specific threats following bridge security guidelines (e.g. AASHTO)
- Therefore, DSI's Cable Hardening system is designed according but not limited to the typical and notable threats as shown in table below
- Adaptable for bridge retrofitting applications using half-shell technology

Cable Hardening shows advantageous performance characteristics:

- Eases installation and is adjustable to different bridge construction methods
- Can be adjusted to any kind of bridge construction layout within anchorage and transition zones
- Incorporates adjacent functional cable units like dampers either internally or externally
- Allows easy inspection and maintenance of the protection system itself but also the stay cable system in general

CABLE HARDENING THREAT RESISTANCE

Threat	Type	Available
Fire	Hydrocarbon Fire	Yes
Explosive Device	HEIED	Yes
	VBIED	Yes
Non Explosive Device	Thermal Cutting	Yes
	Mechanical Cutting	Yes
	Exothermic Lance	Yes

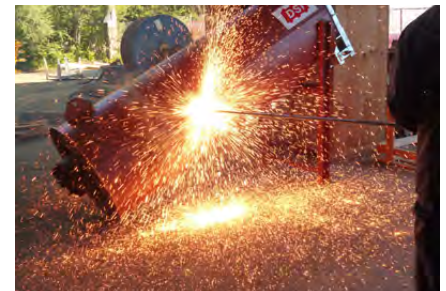

Exothermic Lance

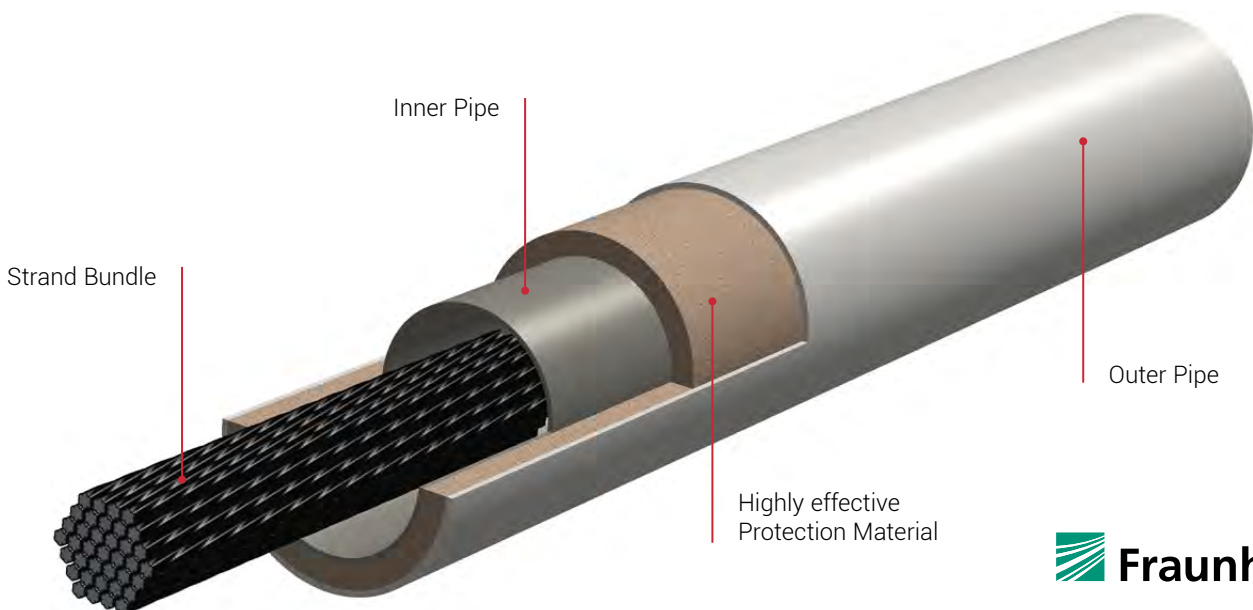

FIRE PROTECTION

Lightning, a car accident or other external incidents may cause fire on a bridge. In that case, the main parts of the stay cable system need to be protected against damage.

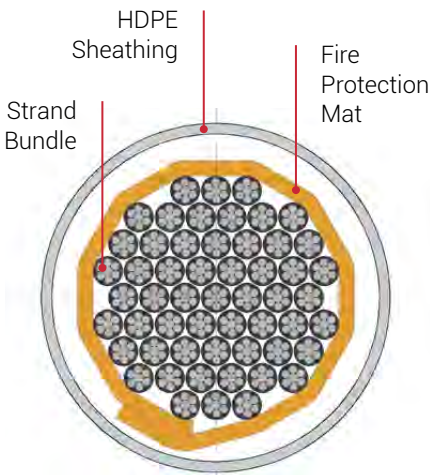

FIRE PROTECTION MATS FOR THE FREE CABLE LENGTH

DSI's stay cable system fully complies with PTI requirements for fire resistance and has been verified using the load capacity test at 300°C.

Furthermore, special fire protection mats resist a 1,100°C hydrocarbon fire for at least 30 minutes without the strands heating up to above 300°C, thus fully complying with PTI requirements.

- Used for the free length of the stay cable
- Covered by standard HDPE sheathing
- Mats have a hydrophobic behavior to avoid water absorption
- Any other fire resistance period can be achieved easily by modifying the mat thickness
- Application in cable transition zone is possible

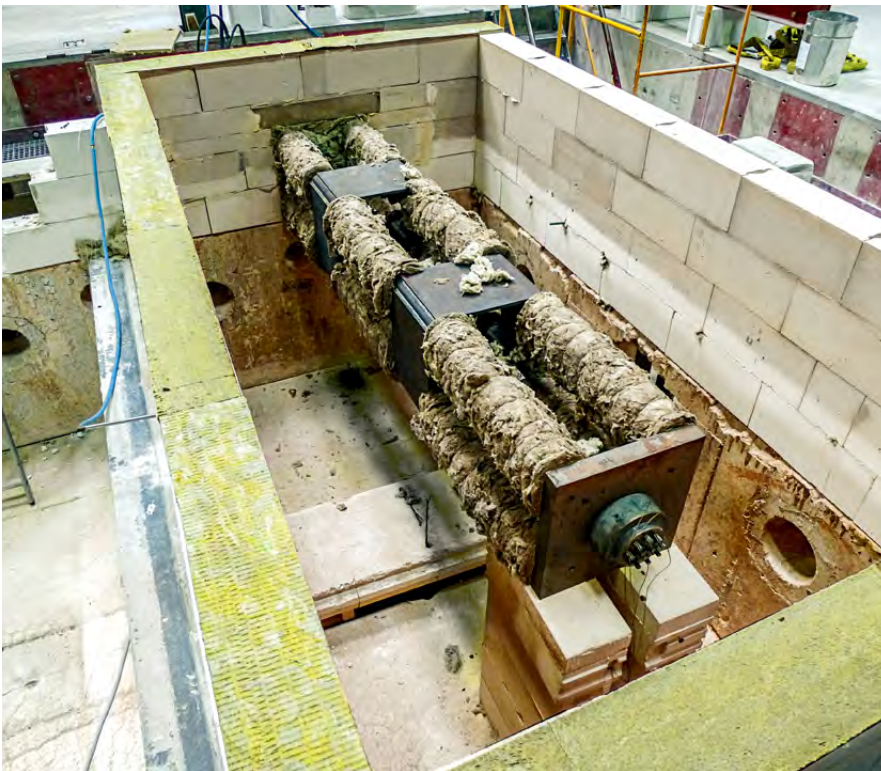

ANCHORAGE AREA

- Steel parts in the anchorage area can be coated with a special fire protection coat that is intumescent under heat impact and thus protects the steel parts
- Protection has been demonstrated during laboratory tests
- Fire protection coating fulfills the highest requirements according to standard ISO 12944, corrosivity class C5

ANCHORAGE PROTECTION SYSTEM

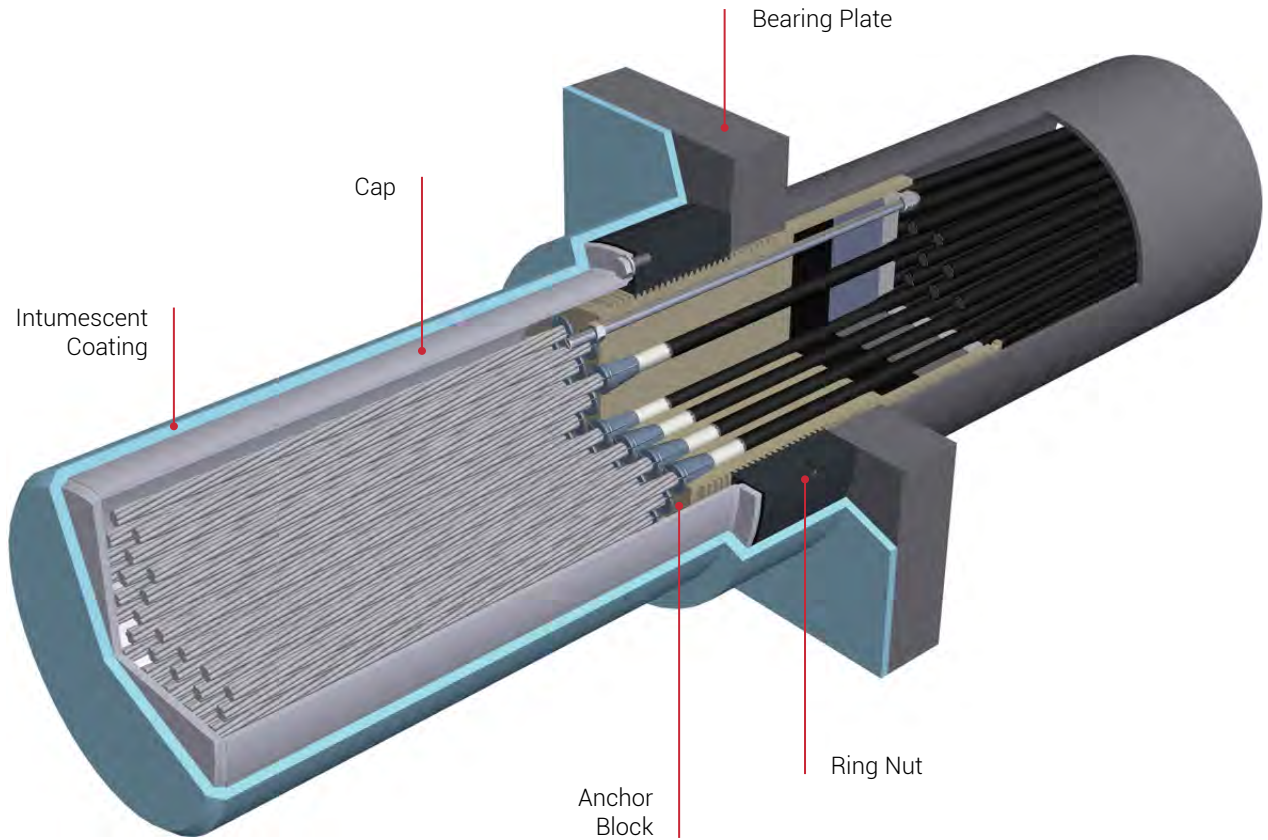

CABLE DE-ICING

Methods are available to reduce the risk of snow and ice accumulation falling from stay cables and endangering traffic running on the bridge's superstructure.

Patented measurements are designed, eliminating the risk of harming the cable structure. In order to comply with client specific needs in dependence of different climatic conditions,

DSI closely cooperates with globally recognized expertise and testing facilities.

CLEVIS ANCHORAGE

- Architectural requirements for the design of stay cable bridges are steadily increasing. Pylons often need to be as slim and elegant as possible.
- Solutions are needed in which the stay cables are connected to the structure outside of the pylon if the space inside the pylon is insufficient for common stay cable anchorages that are supported by bearing plates.
- DSI developed the DYNA Grip® Clevis Anchorage for strand cable types DG-P4 to DG-P61 as standard sizes with additional types on request, offering an economic alternative to conventional systems that have been used so far.
- The complete strand cable can be easily pre-assembled on the superstructure and is lifted into its final position afterwards.
- DSI offers special tools for the preassembly of the clevis as well as the mounting of the pin into the clevis hole.
- Restressing of individual strands as well as the replacement of the complete strand bundle is possible.
- This system also offers other DYNA Grip® System advantages.

Fatigue tests were carried out at the Technical University of Munich in accordance with *fib* Bulletin 30 requirements.

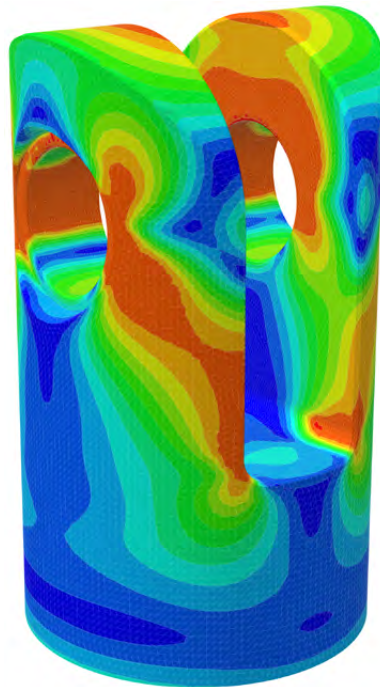

The tests respected an inclination of 0.6° – even towards the inflexible centerline – and an upper load of 0.45 GUTS. They were carried out with a stress range of 200N/mm² at 2 million load cycles.

These dynamic tests, as well as the subsequent static tensile tests, were performed with outstanding success.

The clevis anchorage is not only suitable for stay cable bridges, but can also be used for arch bridge hangers where available space in the arch is too small for aligning ordinarily fixed anchors.

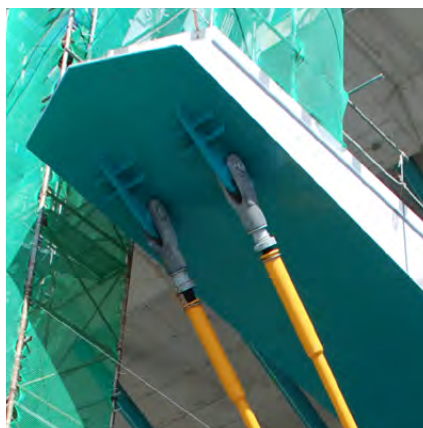
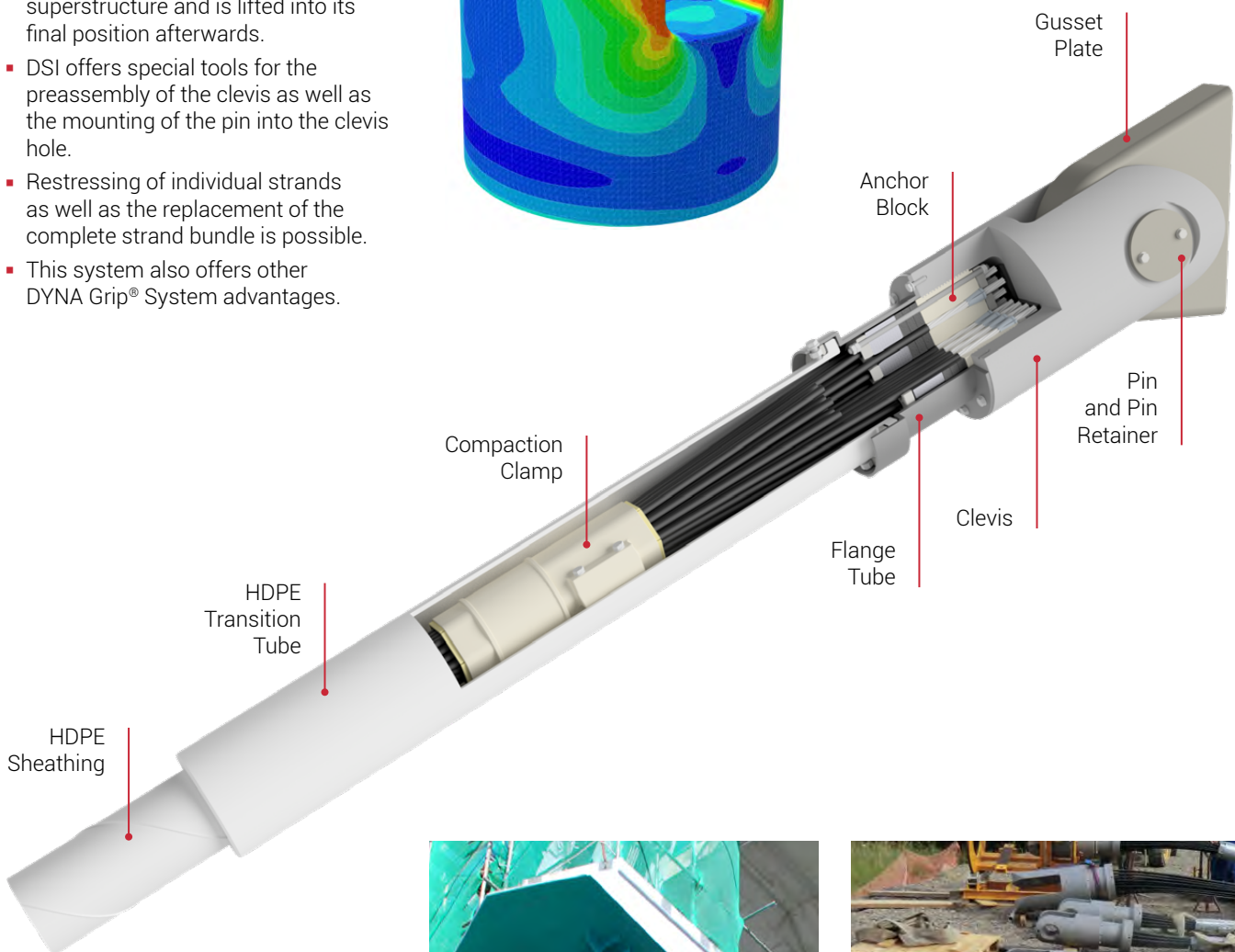

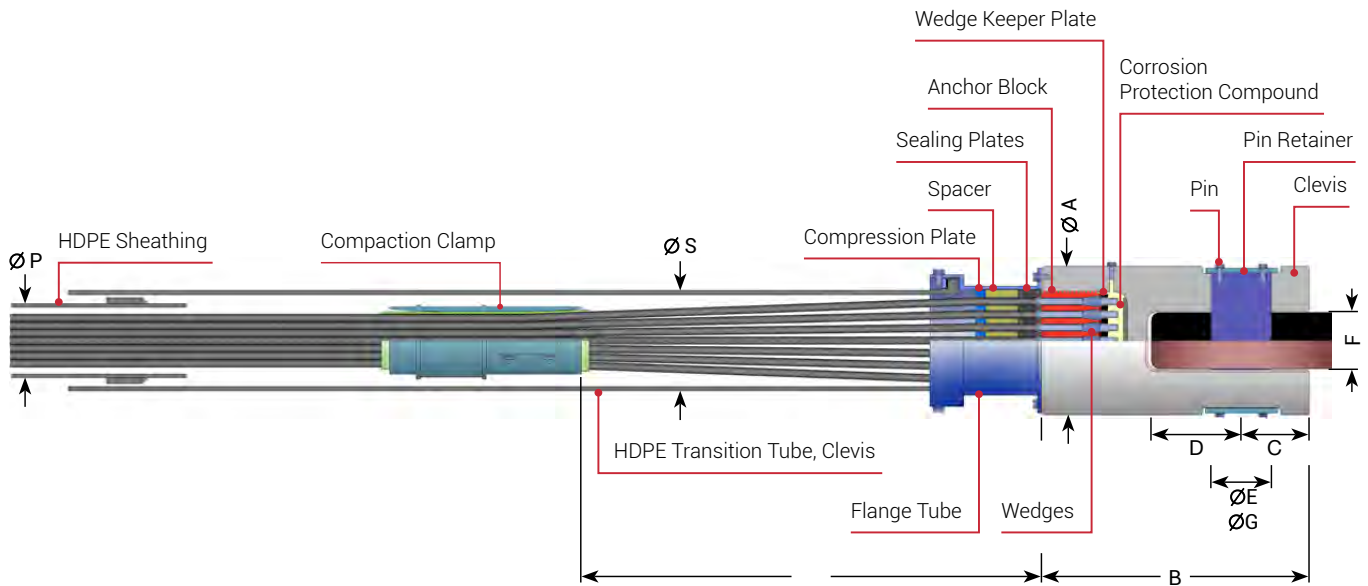

DYNA GRIP® ANCHORAGE – TECHNICAL DATA

(forces calculated with strands 0.62" St 1660/1860)

Cable type *	DG-P4	DG-P7	DG-P12	DG-P19	DG-P31	DG-P37	DG-P43	DG-P55	DG-P61
No. of strands	4	7	12	19	31	37	43	55	61

Forces [kN] **									
Ultimate load at 100% GUTS	1,116	1,953	3,348	5,301	8,649	10,323	11,997	15,345	17,019
Service load at 50% GUTS for stay cables	558	977	1,674	2,651	4,325	5,162	5,999	7,673	8,510
Service load at 60% GUTS for extradosed tendons	670	1,172	2,009	3,181	5,189	6,194	7,198	9,207	10,211

Dimensions [mm]										
Clevis	Ø A	150	200	246	290	351	390	432	463	493
Clevis length	B	350	385	436	528	616	667	720	810	838
Clevis	C	67	82	105	136	170	191	211	239	252
Gusset plate	D	88	108	136	177	221	241	264	301	311
Pin	Ø E	52	67	85	115	138	150	170	195	202
Gusset plate	F	52	63	90	100	125	140	160	175	195
Gusset plate hole	Ø G	54	69	87	117	140	152	172	197	204
Distance of compaction clamp	H	400	510	740	940	1,210	1,360	1,550	1,610	1,780
HDPE sheathing	Ø P	63	90	110	125	160	180	200	200	225

* Bigger size on special request

** Load design guidelines have to be considered

DYNA® Link Anchor Box System

The DYNA® Link Anchor Box System is based on a conventional steel structure in which stay cables are anchored with standard DYNA Grip® anchorages. The DYNA® Link curved Anchor Box is economically designed using conventional steel construction standards to ensure capacity, serviceability and excellent fatigue characteristics. Differential forces are transferred to the concrete by shear studs in regular design, which are welded to the outer surface of the Anchor Box flanges.



ADVANTAGES IN COMPARISON TO CONVENTIONAL PYLON SOLUTIONS

The DYNA® Link Anchor Box features many advantages in comparison to conventional pylon solutions in which cables are anchored inside the pylon section:

- When using DYNA® Link Anchor Boxes, pylon dimensions can be significantly reduced by eliminating anchorages inside the pylon. This allows slender and aesthetical pylon shapes.
- The pylon does not need to be hollow to allow access for installing, stressing and servicing the anchorages.
- Total cost and construction time of the pylon can be reduced.
- Easy and fast installation of box and stay cable with minimum manpower during cable installation.
- The horizontal load can be transferred directly through the DYNA® Link Anchor Box with reduced stresses within the concrete.

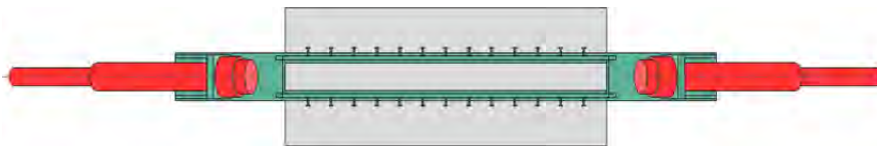

DYNA® Link Anchor Box

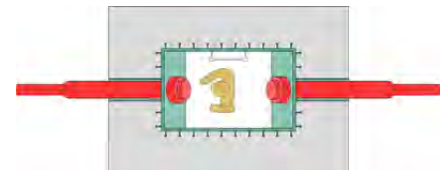

Accessible Steel Box



ADVANTAGES IN COMPARISON TO CONVENTIONAL SADDLE SOLUTIONS

The DYNA® Link Anchor Box features many advantages in comparison to conventional saddle solutions in which strands are guided through the pylon:

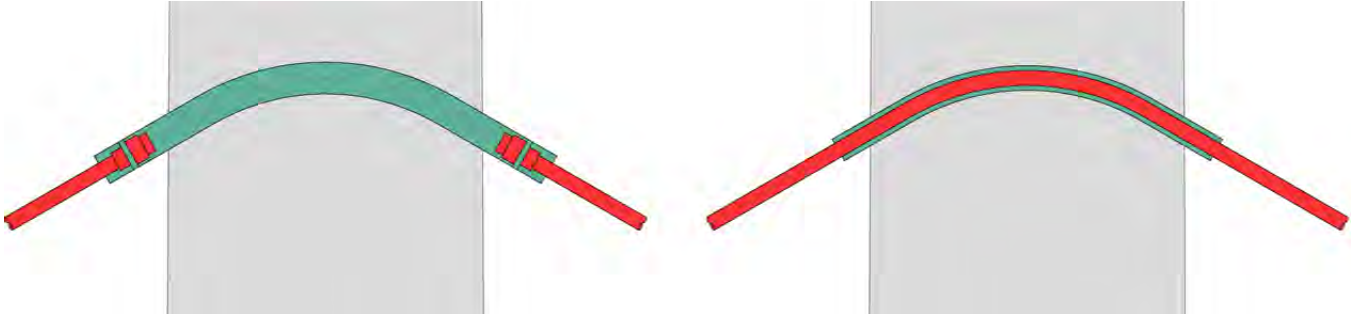

DYNA® Link

Conventional Saddle

Topic	Description	Conclusion
Bridge Design	<p>The use of conventional saddles results in equal strand numbers on both sides of the tower for each cable. This outcome might not be the most efficient or desirable from an economical and behavioral point of view. This is evident for end spans that have a considerably larger stiffness than adjacent main spans and particularly for cables anchored close to end supports.</p> <p>There is also uncertainty on what is the effective cable length to be used in the structural analysis. This uncertainty stems from the fact that a certain length of the curved strands inside the saddle will be subjected to varying axial strains. This effect may be significant for the shorter cables of Extradosed bridges.</p>	<p>With the DYNA® Link Anchor Box, the stay cable assembly is flexible. Different cable sizes can be used, and the effective cable length with a working point at the anchorage is clearly defined.</p>
Friction Factor and Slip Limit State	<p>Slip in conventional saddles is prevented by friction between the strands and the saddle. Current design recommendations (such as PTI recommendations and <i>fib</i> Bulletin 30) require that the friction factor be derived from tests on specimens representing the parameters of the actual saddles. These tests are conducted in the laboratory in dry and controlled conditions. Due to possible contamination or condensation, the conditions in an actual saddle on site may be quite different from the test conditions. This creates uncertainty as to the actual friction factor available to resist differential cable forces during the construction and service stages of the bridge.</p> <p>Slip of strands inside a saddle must be completely avoided. This is an additional limit state that must be investigated and verified by the bridge designer. This limit state is not related to the strength of the cable components, but depends on the friction between strand and saddle and the magnitude of the cable forces at both ends of the saddle. Additional load cases and combinations may need to be investigated using advanced analytical methods, to ensure that this limit state would not be violated.</p>	<p>By means of the DYNA® Link Anchor Box, the full cable force can be reliably taken at each side of the pylon. There is no limitation by a friction factor and there are no uncertainties of friction at different climatic conditions. Friction tests and additional slip limit stage investigations within the structural computation are not required.</p> <p>DYNA® Link Anchor Boxes can even be used in seismic regions where friction type saddles are not recommended.</p>
Bending and Transverse Stresses	<p>Due to the curvature of saddles, bending and transverse stresses are transferred to the strands. The bending stresses will reduce the axial strength of the strands. The transverse stresses may result in fretting effects between the strand wires or between the strands and the saddle that will result in reduced fatigue strength of the strands.</p>	<p>At the DYNA® Link Anchor Box, the strands are not deviated along the saddle. Therefore, the fatigue performance and durability is not compromised, and existing full size fatigue and leak tightness tests of DYNA Grip® stay cable tests can be used. Furthermore, there are no limits in the respective saddle radii.</p>

ADVANTAGES TO CONVENTIONAL SADDLE SOLUTIONS

Topic	Description	Conclusion
Bridge Construction	<p>The use of cable saddles results in doubling the man power and equipment required for the installation and stressing of cables. In addition, saddles require the pace of cantilever construction on both sides of the tower to always be symmetrical before a cable may be installed. This results in increased construction costs and inefficient utilization of resources.</p>	<p>The DYNA® Link Anchor Box provides full flexibility for the construction cycle, as cables may be installed alternately so that the overall construction time can be significantly reduced.</p>
Cable Inspection and Maintenance	<p>Saddles do not allow the inspection of strands inside them. This may be critical because the strands are anchored by friction inside the saddle pipes and are subjected to multi-axial stresses and differential movements due to live and dynamic loads.</p> <p>These conditions may adversely impact the design life of the strands and their corrosion protection system; and this uncertainty may not be acceptable to bridge owners.</p>	<p>The durability of the DYNA® Link Anchor Box is not compromised, as there are no strands which are deviated. Window opening at the DYNA® Link Anchor Box allows easy access for inspection and maintenance. It is even possible to replace a complete strand bundle only on one side of the pylon.</p>

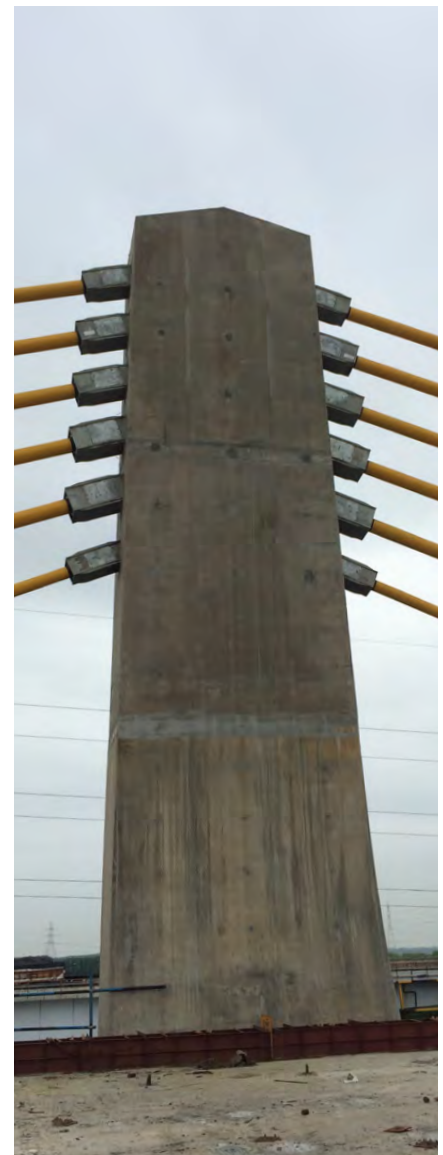

STAY CABLE INSTALLATION

Depending on the pylon dimensions and cable layout, the DYNA® Link Anchor Box may either be provided with a lateral or a top access at the pylon interface for stay cable installation.

Standard solutions for both options have been designed for each cable type using Finite-Element Analysis software with the following design assumptions which are based on SETRA:

All standard solutions can be adapted easily to any project specific demand, and thus, the actual pylon dimension, cable angles as well as design loads will be taken into account.

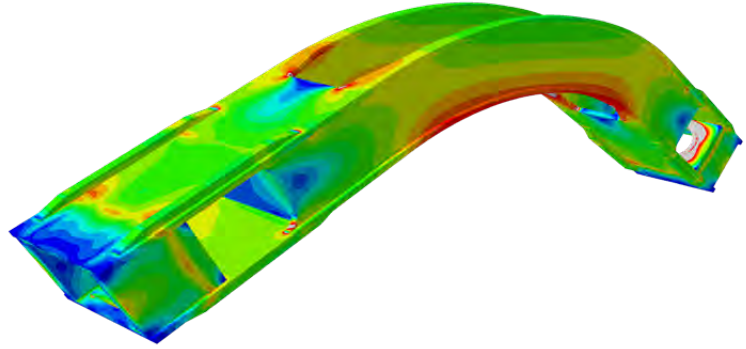

Von Mises stresses of a DYNA® Link Anchor Box with lateral access

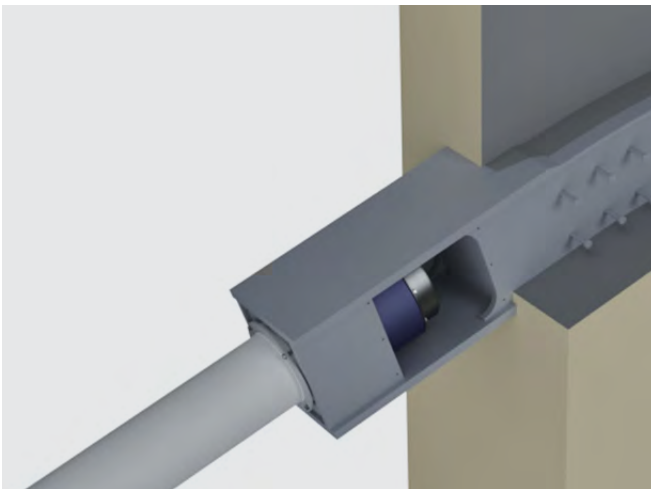

Lateral Installation opening for DYNA Grip® Stay Cable Anchorage

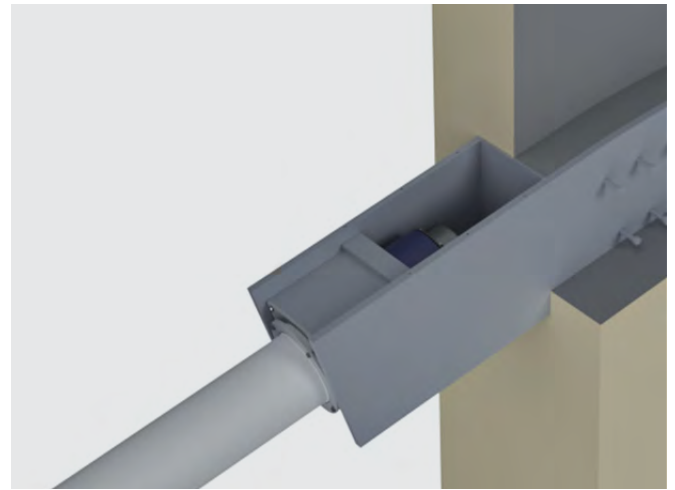

Open top Installation opening for DYNA Grip® Stay Cable Anchorage

Type	Load Level	Deviation
ULS DESIGN LOAD	90 % GUTS	+ 25 mrad deviation angle
SLS DESIGN LOAD	45 % resp. 60 % GUTS (stay cable resp. extradosed)	+ 25 mrad deviation angle
FLS DESIGN LOAD	200 MPa at 45 % GUTS resp. 140 MPa at 60% GUTS	+ 10 mrad deviation



Saddle Solution

SADDLE WITH INDIVIDUAL TUBES

If strands need to be guided through the pylon structure and a transfer of forces by friction is required, DYWIDAG offers a saddle in which the strands are guided from one side of the pylon to the other:

- Strands are placed into a multitude of individual, curved recess tubes. The interstices between the saddle tube and the recess tubes are grouted
- The saddle itself is embedded into concrete
- Individual strands can be replaced
- Differential forces are transferred by friction
- Application of Epoxy coated strands and consequently:
- no peeling of strands' sheathing within the saddle necessary
- no pressure; the coating is therefore not in danger of being harmed, which can occur when using PE-sheathed strand



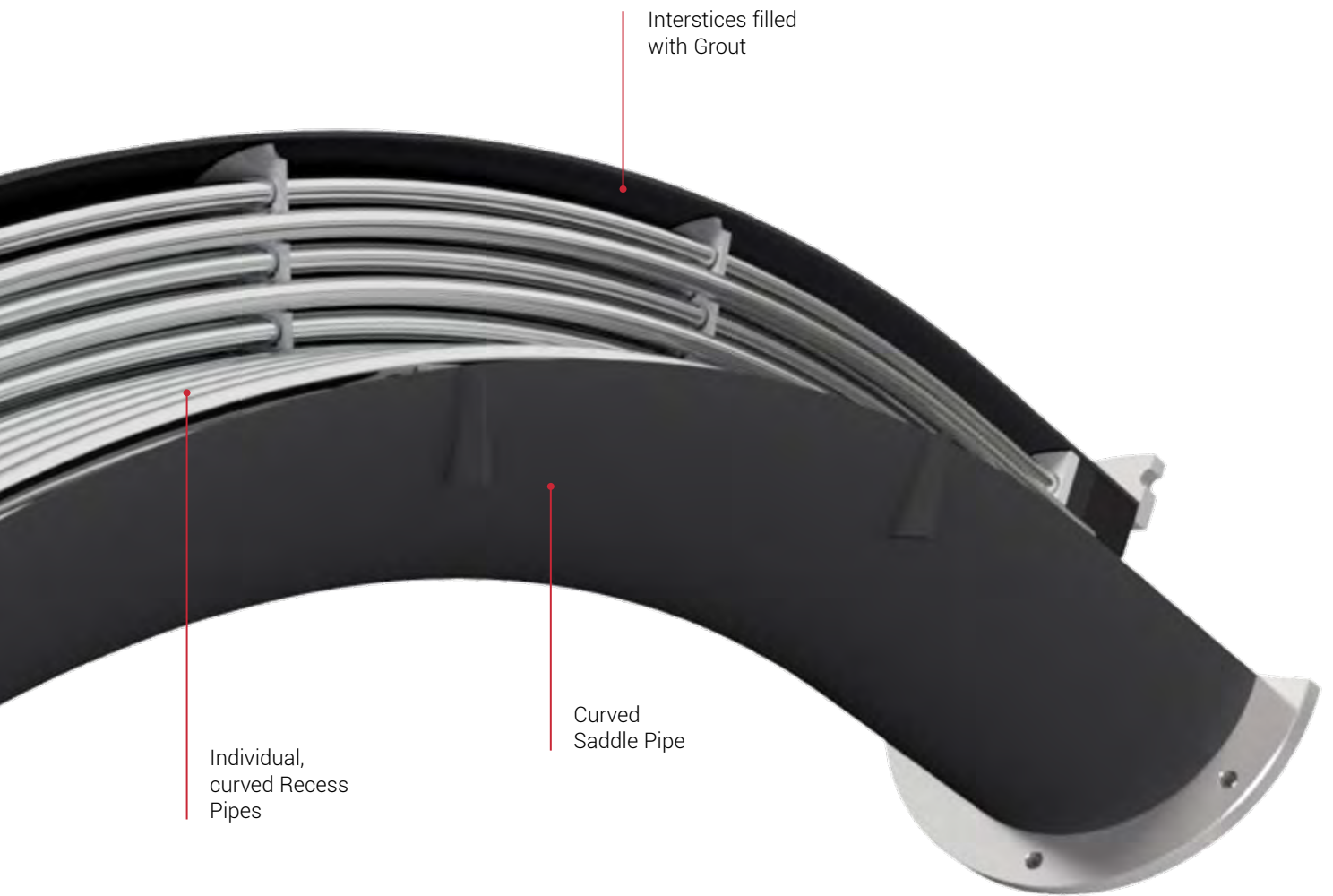

Fully Grouted Solutions

DYNA BOND® ANCHORAGE

The DYNA Bond® Anchorage consists of a conical steel pipe (bond socket) supporting a wedge plate in which the strands are anchored with high-fatigue 3-part wedges. A ring nut is fitted on the threaded end of the bond socket and distributes the cable force through a bearing plate into the structure.

- During the construction period – prior to grouting the bond socket – all the applied loads are supported directly by the wedges.
- At the final state of construction, all additional loads (live loads, vibrations and earthquakes) are partly resisted by both wedges and grouted bond socket.

- DYNA Bond® Anchorages have an excellent fatigue resistance because the bond action in the bond socket substantially reduces the magnitude of the dynamic loads reaching the wedge anchorage. Fatigue tests have proven a stress range of up to 240N/mm² at an upper load of 45% GUTS and 2 million load cycles.

ADDITIONAL ADVANTAGES

- Minimized bending effects at the anchorage by placing an elastomeric bearing inside the recess tube
- Reliable corrosion protection for the sensitive anchorage area, as all voids in the anchorage zone are filled with a stable and robust filler
- Enhanced fire resistance and protection against vandalism, impact loads and blast effects

- Easy fixation of external dampers directly on the grouted stay pipe
- A special patent protected sealing provision allows to grout the anchorage area only so that the free length remains without grout

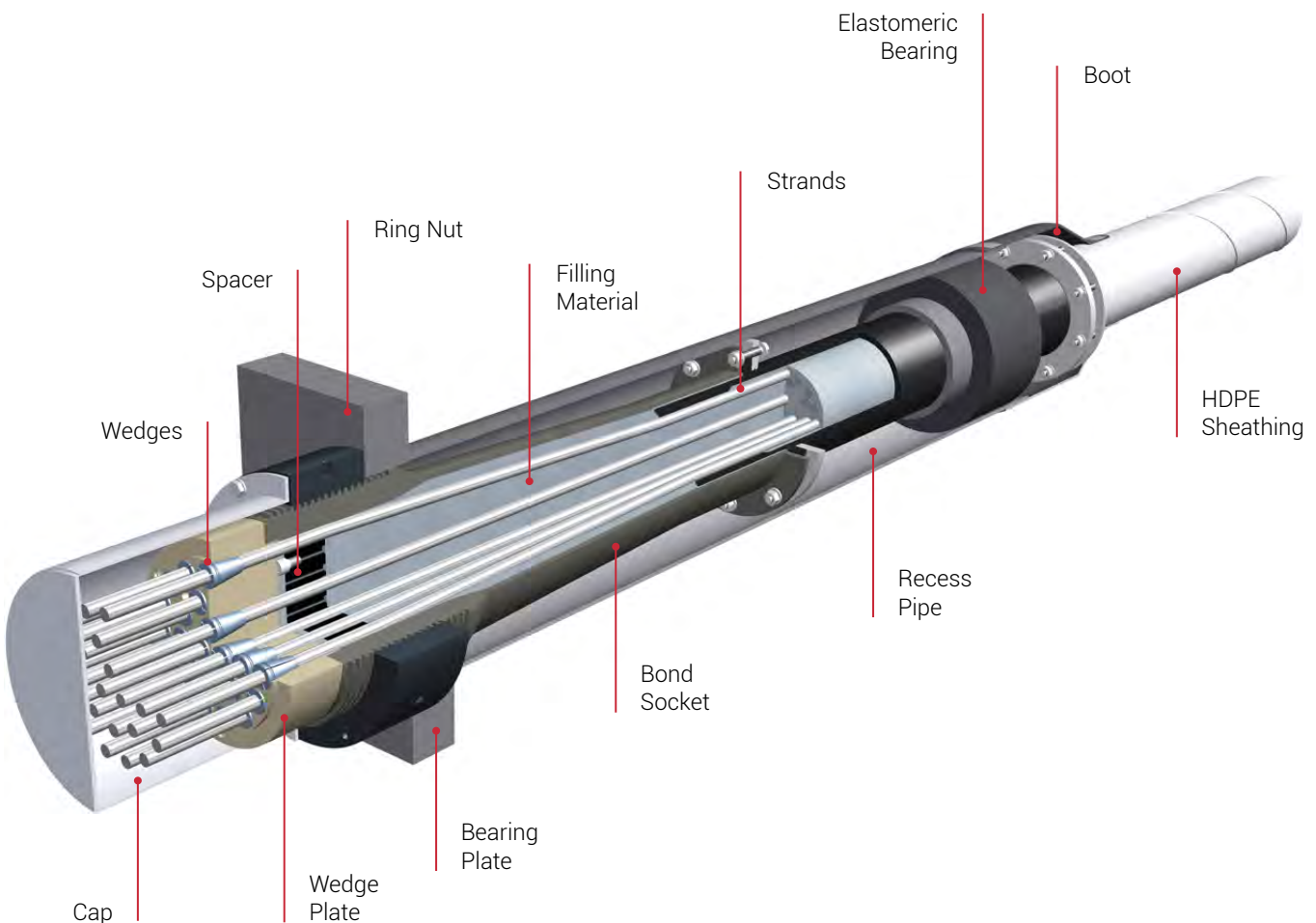

SADDLE WITH ANCHOR GROOVE AND PIN

The saddle transfers differential forces via a shear nose with pin into the pylon concrete construction.

- Strands (without PE coating inside the saddle) are guided in a curved tube and injected in the deviation area using special grout
- The strand bundle including saddle pipe can be exchanged if necessary
- An inner, curved saddle pipe is guided through an outer recess pipe that is embedded into the concrete
- Differential forces in the stays at both sides of the saddle are reliably transferred via a shear nose (anchor groove – pin construction)

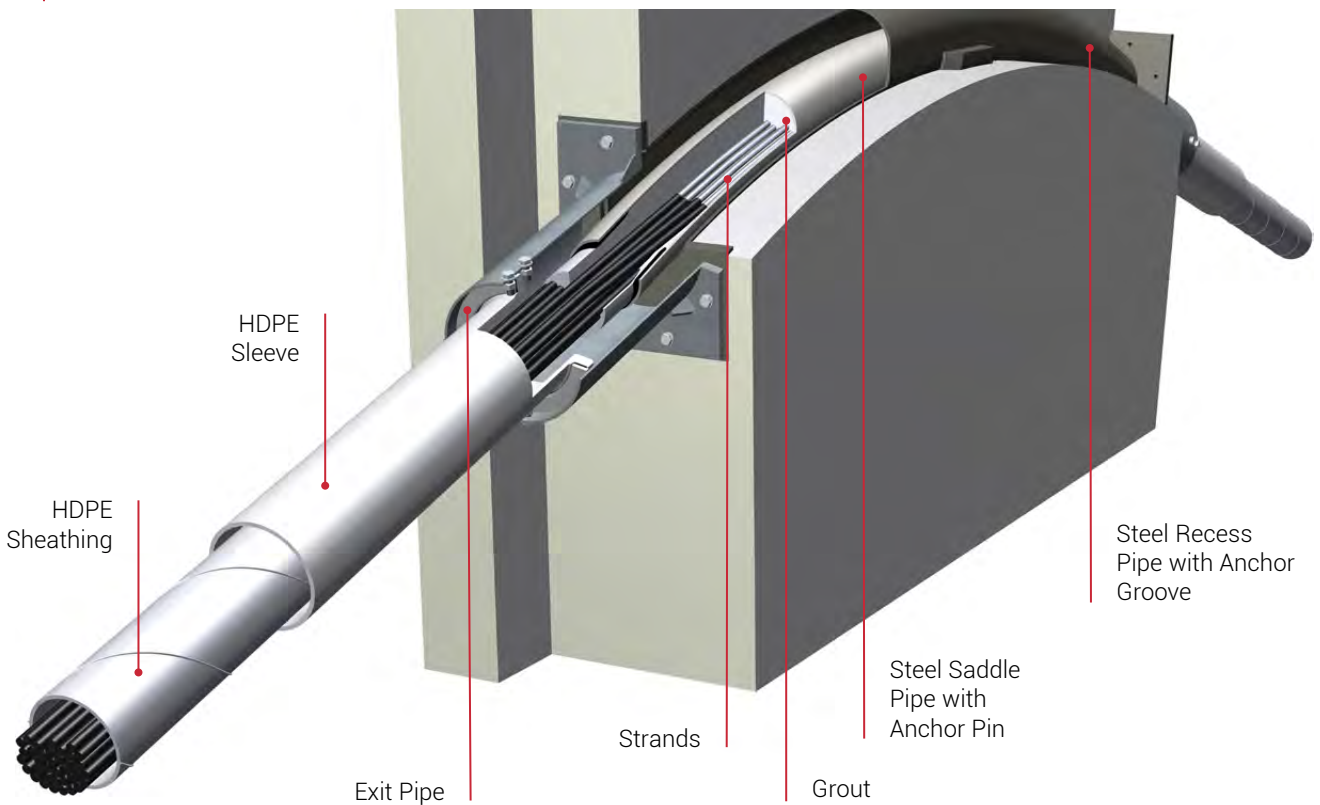
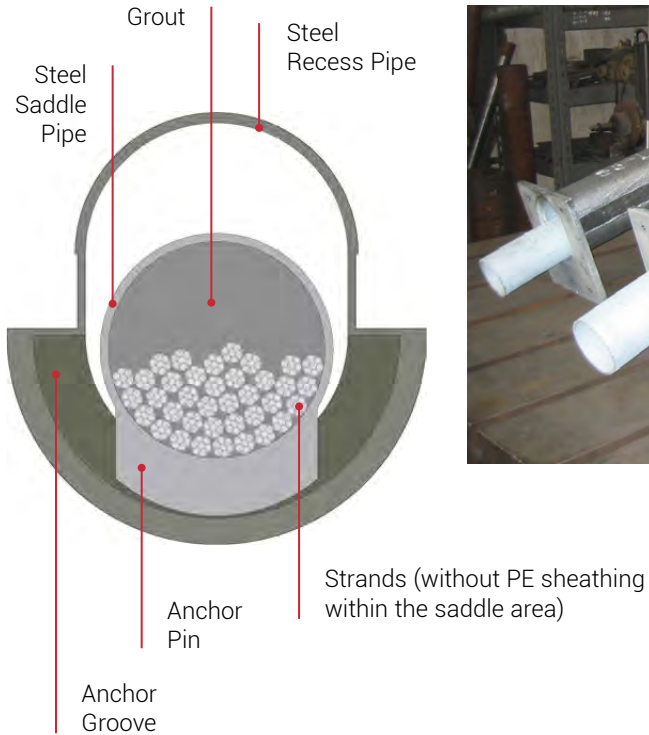

Strand and Wedge

DYWIDAG Stay Cables use strands that meet the requirements of *fib* and *PTI-Recommendations* for stay cables, *ASTM*, *BS* as well as other national or international standards.

Generally, the following types of strands are used:

- 7 cold-drawn galvanized wires
 - PE-sheathed with minimum thickness of > 1.5mm in accordance with *fib* Bulletin 30
 - Low relaxation strand
- Wax as a void filler for the interstices between wires and PE sheathing
 - Diameters up to 0.62" and steel grades up to 1,860N/mm²
 - Strands are anchored with specially treated 3-part wedges that are characterized by high fatigue resistance.

EPOXY COATED STRANDS

- Epoxy coated strand is manufactured in compliance with ISO 14655:1999 or ASTM A882. The 3-part wedges are specially designed for epoxy coated strands. The teeth penetrate through the coating so that they grip into the wires of the strand.
- Fatigue tests conducted on single-strand tendons have proven a dynamic stress range of up to 260N/mm² (upper stress 0.45 GUTS at 2 million load cycles).
- Cold-drawn 7-wire strand is coated with epoxy resin in the shop
- Interstices between the 7 wires are completely filled with epoxy resin, thus providing excellent and robust long-time corrosion protection
- Epoxy material reduces fretting action between the individual wires and cushions adjacent strands in deviation areas. It avoids damages within the sensitive wedge gripping area and retains its properties as corrosion protection barrier
- The excellent bond of the epoxy with the steel wires and the ductile behavior of the epoxy material avoids damages within the sensitive wedge gripping area and retains its properties as a corrosion protection barrier
- An additional PE sheathing on top of the epoxy coating is possible, protecting strands from damage during handling and on-site installation



Wedge for Galvanized Strand

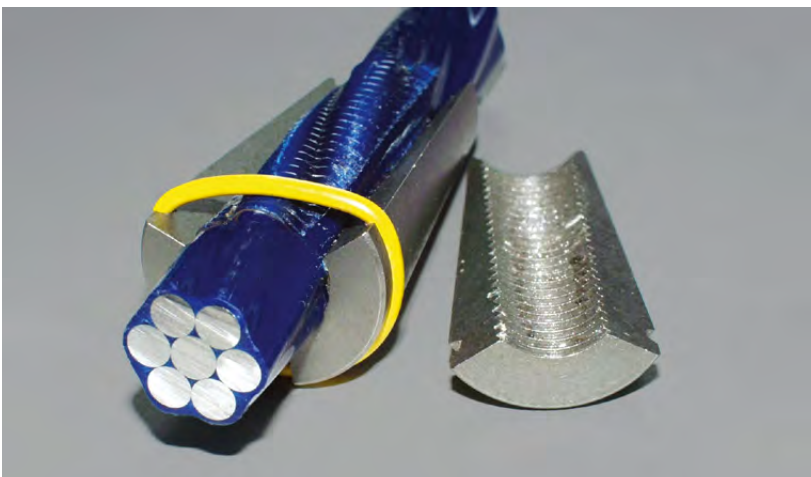

Wedge for Epoxy Strands



Epoxy Coated Strand

OUTER STAY PIPE

STANDARD PIPE

- HDPE pipes serve as protection against environmental influences and are typically used as outer covers of DYWIDAG Stay Cables. Main characteristics:
- Wind load reduction at the cable
- Outer helix with demonstrated efficiency against rain-wind induced cable vibrations
- Co-extruded or fully colored pipes
- Wide range of colors
- The excellent UV-resistance has been proven in accelerated aging tests
- Steel or stainless steel pipes are available on special request

SLIM DUCT

- For long span bridges, lateral wind loading at the cables needs to be taken into account for pylon design. To reduce the wind load, DSI offers slim sheathing with reduced pipe diameters.



Standard Duct



Slim Duct

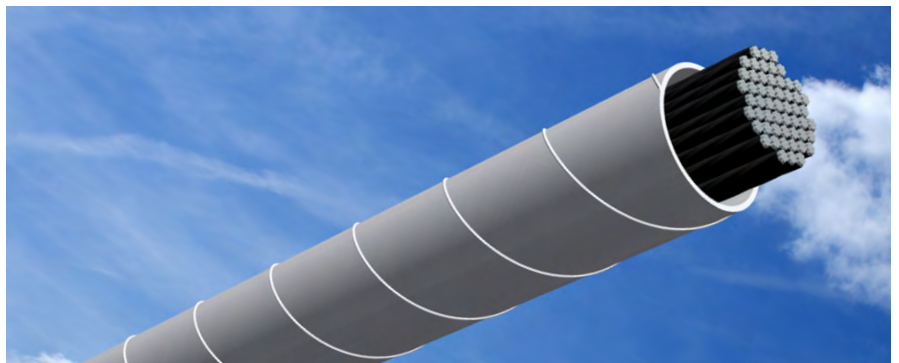

HDPE Sheathing with Helix



Stainless Steel Duct

Cable Damping

Slender supporting structures and long cable lengths make stay cables susceptible to vibrations. Big vibration amplitudes may result in damages to the cable due to bending and fatigue loads. This decreases a cable's durability and may even endanger structural safety.

Depending on the respective cable parameters, each cable is more or less prone to vibration. Longer cables are more likely to vibrate than short ones. Nevertheless, cables with lengths above 200m have been installed without additional dampers without any vibration problems. On the other hand, even very short cables sometimes need dampers.

By experience, DSI recommends to increase a cable's inherent damping by using additional damping devices for cable lengths above 80m. Cables start vibrating when they are excited. Please find following some excitation causes and methods for mitigating their effects.



EXCITATION CAUSES

BUFFETING

- Wind causes drag, lift and moment forces on cables that result in cable vibrations. Depending on the boundary conditions, inherent damping of a stay cable without additional damping might not be high enough to decrease these vibrations to an acceptable amplitude.

VORTEX-SHEDDING

- Uniform wind flow causes turbulent vortices to detach, alternating from a cable's top and bottom side, so that vibrations are caused. The amplitudes are usually small compared to the cable diameter. However, resonance of the vortex shedding frequency and cable eigenfrequencies can result in larger amplitudes.

GALLOPING

- Galloping affects rectangular shapes or round shapes with asymmetry. If the wind speed is above a critical value, vortices detach from the edges and create similar effects as vortex shedding. However, contrary to vortex shedding, galloping results in high amplitude vibrations.

WAKE GALLOPING

- Wake Galloping occurs at cables that are closely spaced in wind direction. Vortices behind one cable excite the cable that is next to it and lead to vibrations.

ICED GALLOPING

- Ice that sticks to a round cable can alter its cross section in such a way that galloping occurs above a critical wind speed.

RAIN-WIND INDUCED VIBRATIONS

- During specific combinations of rain intensity, wind speed, wind direction and cable inclination, water rivulets arrange at the cable's top and bottom surface. Due to wind, they move a few degrees around the cable circumference and induce vibrations into the cable. This happens at relatively low wind speeds.

PARAMETRIC EXCITATION

- Parametric excitation is caused if the excitation acts on other parts of the structure (such as the pylon), and if this vibration is transferred into the cables.
- DSI not only supplies the appropriate damping devices but also supports bridge designers and owners in choosing a damping concept that is customized to their specific project needs.

OUTER HELICAL FILLET

- To mitigate rain-wind induced vibrations, a double helical fillet is applied on the surface of outer stay pipes
- Different diameters have been tested in climatic wind tunnel tests
- Demonstrated drag coefficient of $C_D = 0.6$ for large cable diameters

DRAG COEFFICIENT FOR STAY PIPE

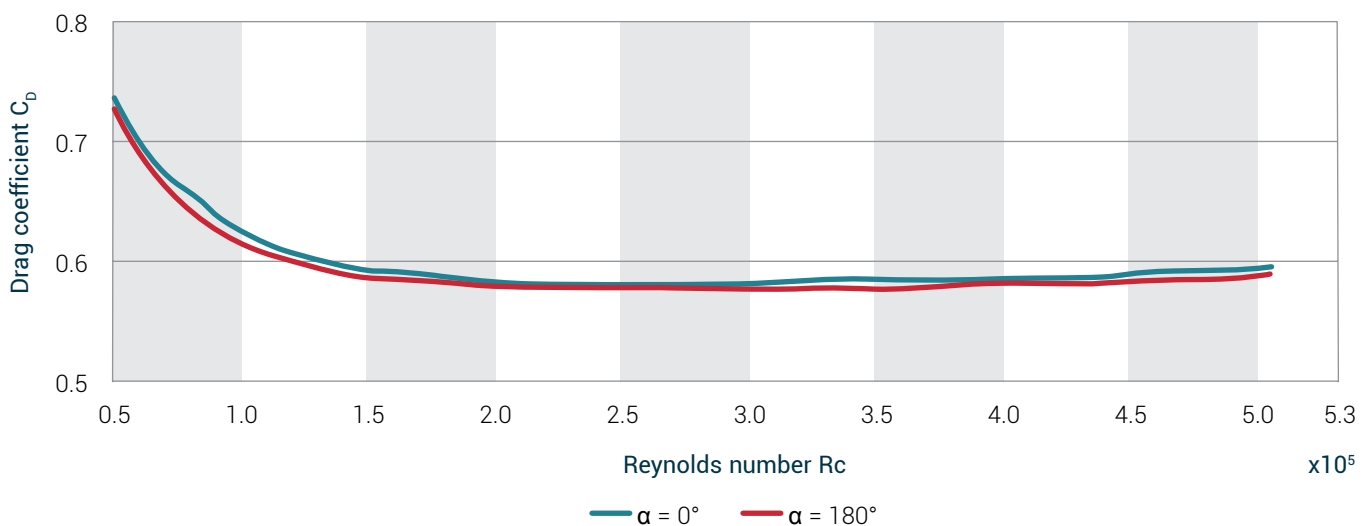

DAMPER DESIGN

- Sufficient damping prevents cables from vibrating. DSI recommends damping values of at least 3–4% logarithmic decrement δ to be reached for the first two to three vibration modes depending on each cable's boundary conditions and on project specific requirements. These damping values can usually not be achieved by inherent cable damping so that additional damping is required.
- External viscous dampers provide very effective supplementary damping.
- Special software developed for DSI

EXTERNAL VISCOUS DAMPER

- Efficient dampers can be computed for each cable taking into account several vibration modes
- In plane, the damper is sufficient to also suppress out of plane vibrations
- Slender and aesthetic design; available in several colors

CORRELATION OF ACHIEVABLE DAMPING COEFFICIENT, DAMPING RATIO AND SCRUTON NUMBER

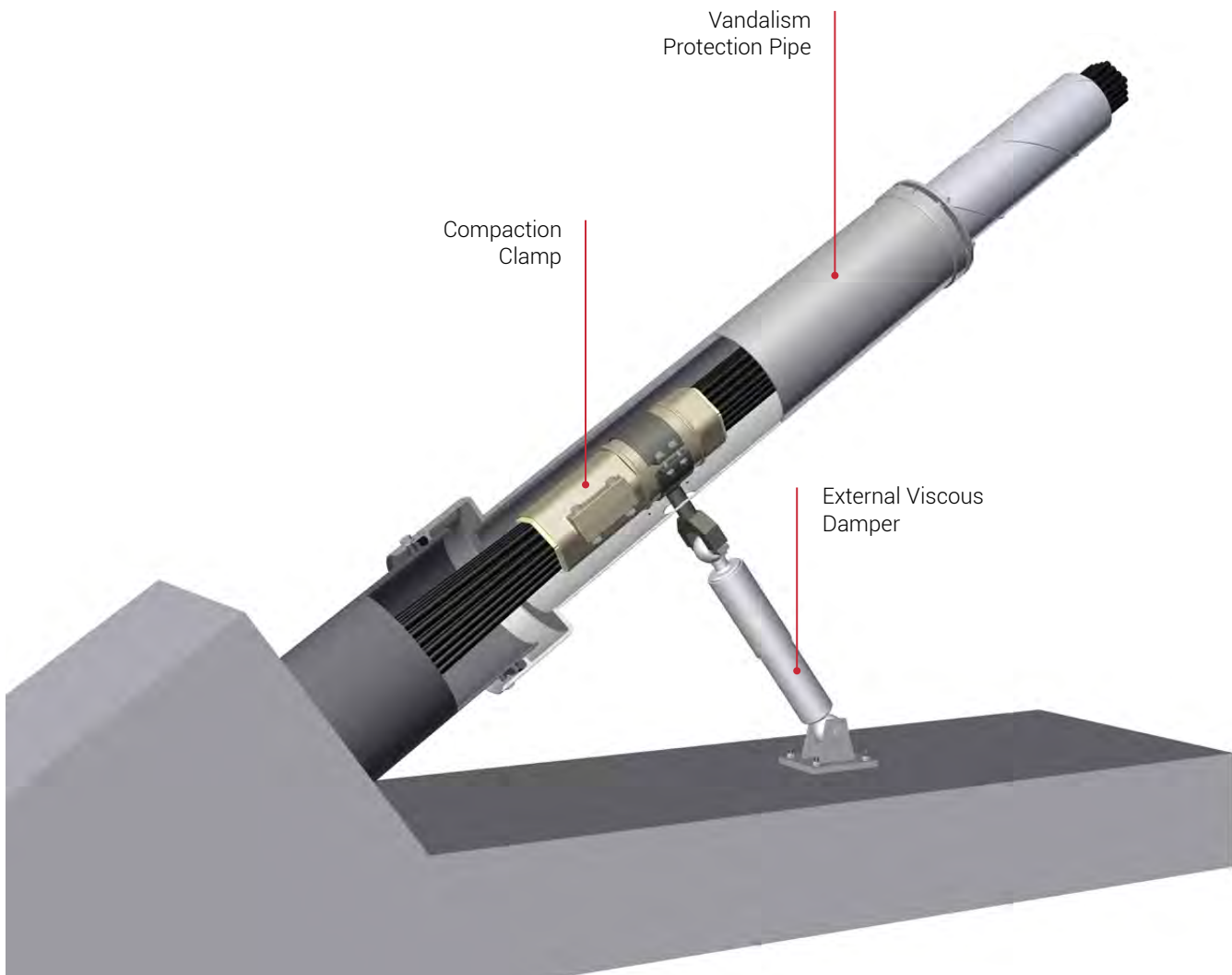
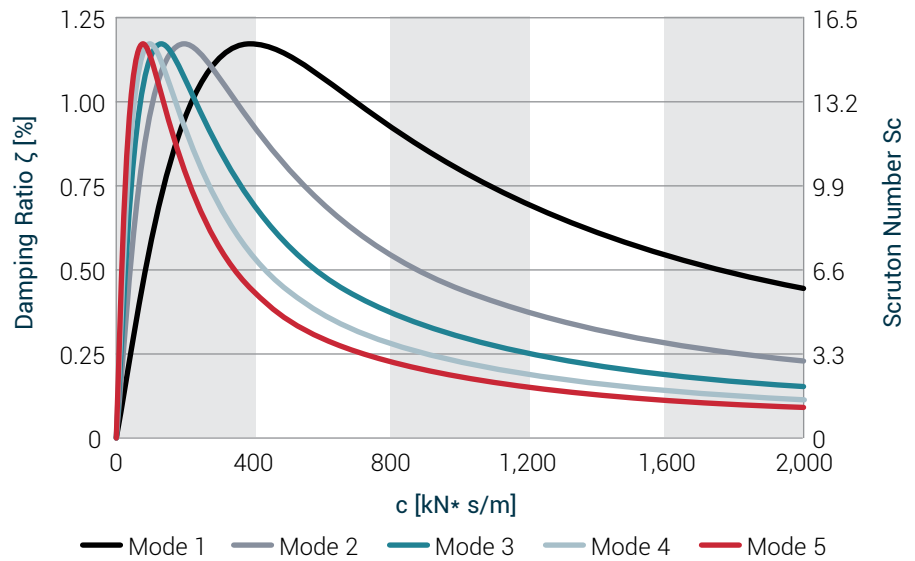

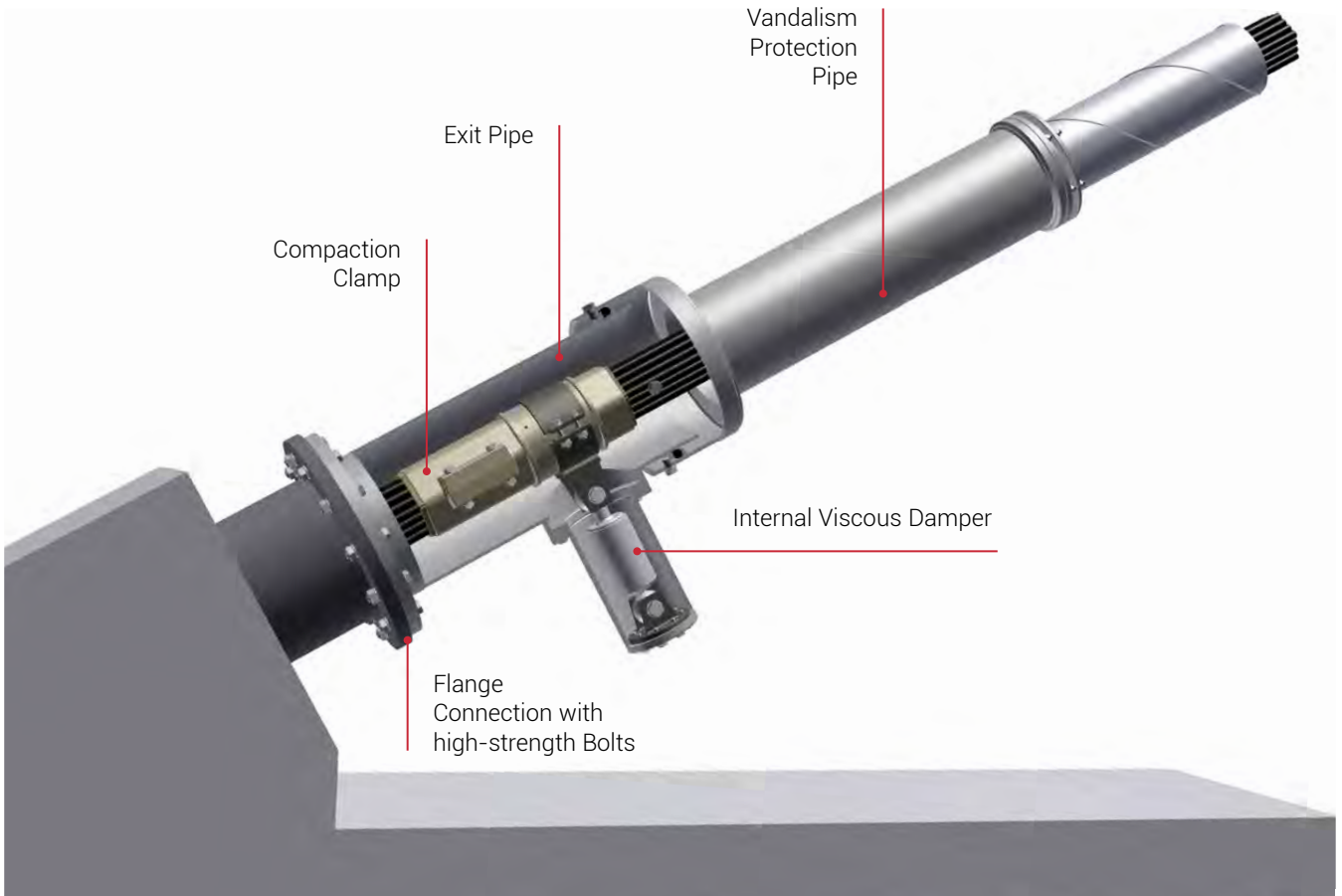

INTERNAL VISCOUS DAMPER

In addition to external viscous dampers, DSI also offers internal viscous dampers that are attached to the exit pipe.

- Damping forces are transmitted from the damper through its steel housing and exit pipe into the recess pipe, from where they are transferred into the superstructure
- Housed dampers are advantageous due to their avoiding additional support structures for connection to the bridge deck
- Since DSI housed dampers do not require a connection point on deck, they can be used at virtually any cable position
- Increased durability is a benefit of housed dampers: they are not affected by weathering
- A stiff flanged connection is required

INTERNAL RUBBER DAMPER

Especially used for short and medium cable lengths

- Internal rubber dampers are placed inside the exit pipe parallel to the cable axis
- Their elastomeric high efficiency material dissipates vibration energy while deforming when subject to shear stress

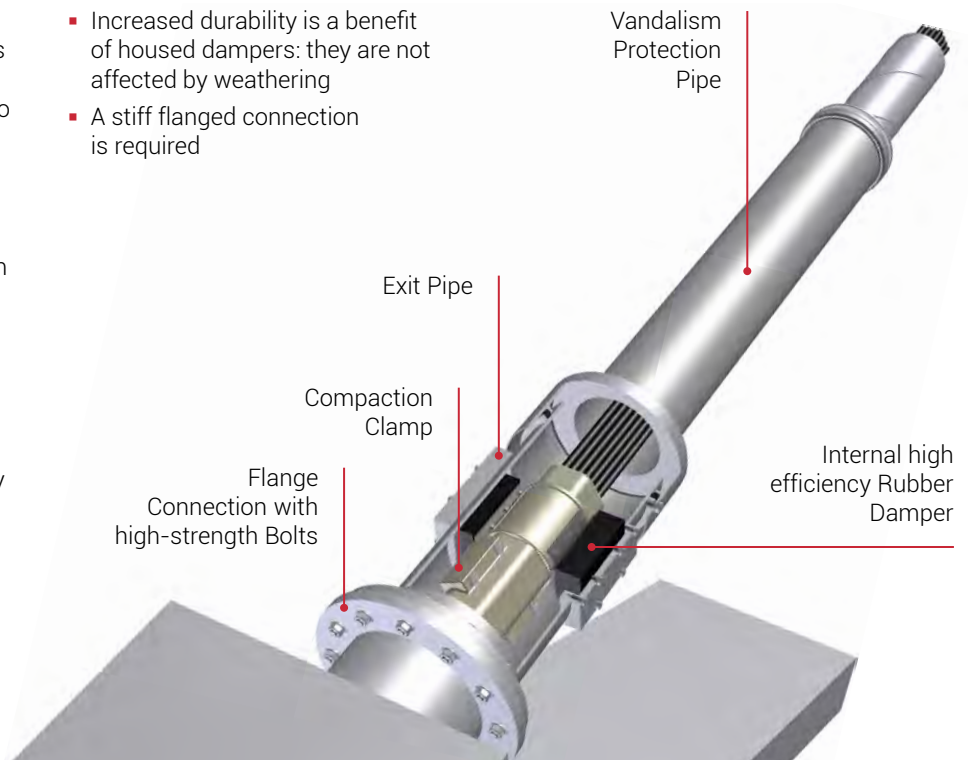

Full Size Testing

DYWIDAG Stay Cables have been successfully tested in numerous static and fatigue tests in compliance with *fib*, SETRA and PTI recommendations. Tests have been conducted in collaboration with renowned Universities such as CTL, TU Munich, TU Vienna, MPA Braunschweig or DTU Copenhagen.



STANDARD FATIGUE AND TENSILE TESTING

- Applying 2 million load cycles
- Stress range of 200N/mm²
- Upper load level of 45% GUTS
- Inclined anchorages of 10mrad

DYWIDAG Stay Cable testing has also been successfully conducted in additional full size tests with increased requirements in terms of upper load and additional angular deviation of the cable system.



FATIGUE AND TENSILE TESTING WITH HIGHER LOAD LEVEL AND ADDITIONAL TRANSVERSE DEFLECTION

- Application of 2 million load cycles
- Stress range of 100N/mm²
- Upper load level of 60% GUTS
- Anchorages inclined by 10mrad
- Deviation of $\pm 25\text{mrad}$ in transversal direction

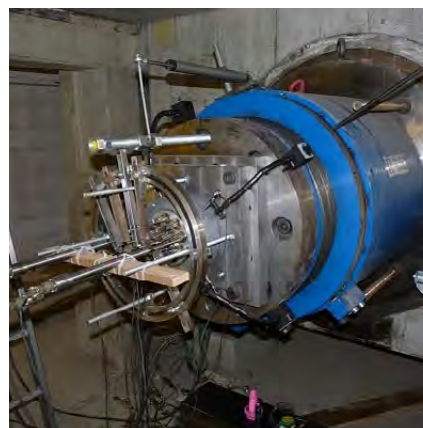
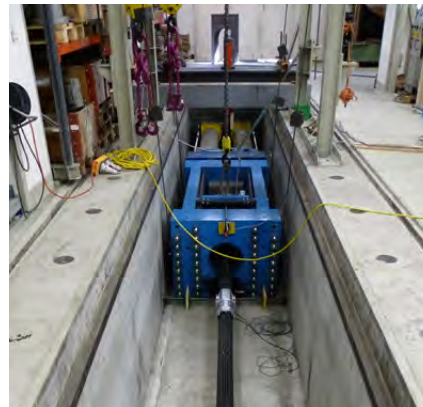

FATIGUE AND TENSILE TESTING WITH ADDITIONAL TRANSVERSE DEFLECTION (SETRA)

- Applying 2 million load cycles
- Stress range of 200N/mm²,
- Upper load level of 45% GUTS
- Transverse deflection resulting in cyclic angular deviation from 0 to 10mrad

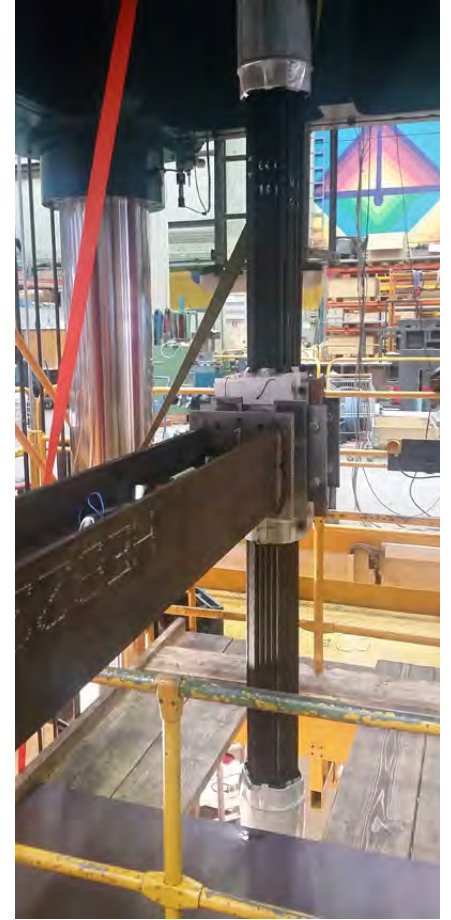

INCREASED LOAD CYCLE TESTING – 10 MILLION CYCLES

- Application of 10 million load cycles
- Stress range of 200N/mm²
- Upper load level of 45% GUTS
- Anchorages inclined by 10mrad

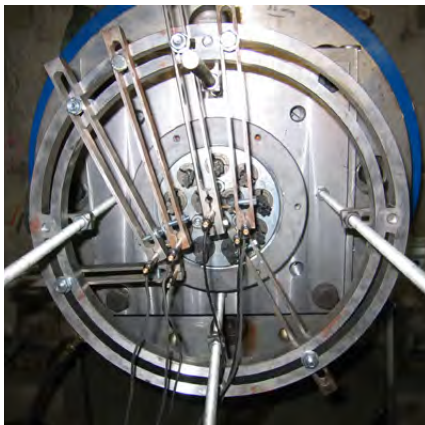

MONOSTRAND FATIGUE TESTING UNDER REVERSED CYCLIC FLEXURAL LOADING

A series of *bending fatigue* tests on galvanized, waxed and PE-coated 7 wire strands 0.62" with an ultimate tensile strength of 1,860N/mm² were successfully performed. They proved that the standard protective measures of the sealing unit within the DYNA Grip® Anchorage are effective for fatigue bending *without* the additional use of a guide deviator.

- Application of 2 million load cycles
- Different upper load levels varying from 45% to 60% GUTS
- Static inclination at the anchorage between 0.6° and 3.0°
- Additional angular deviation at the center of the strand between ± 10mrad and ± 35mrad

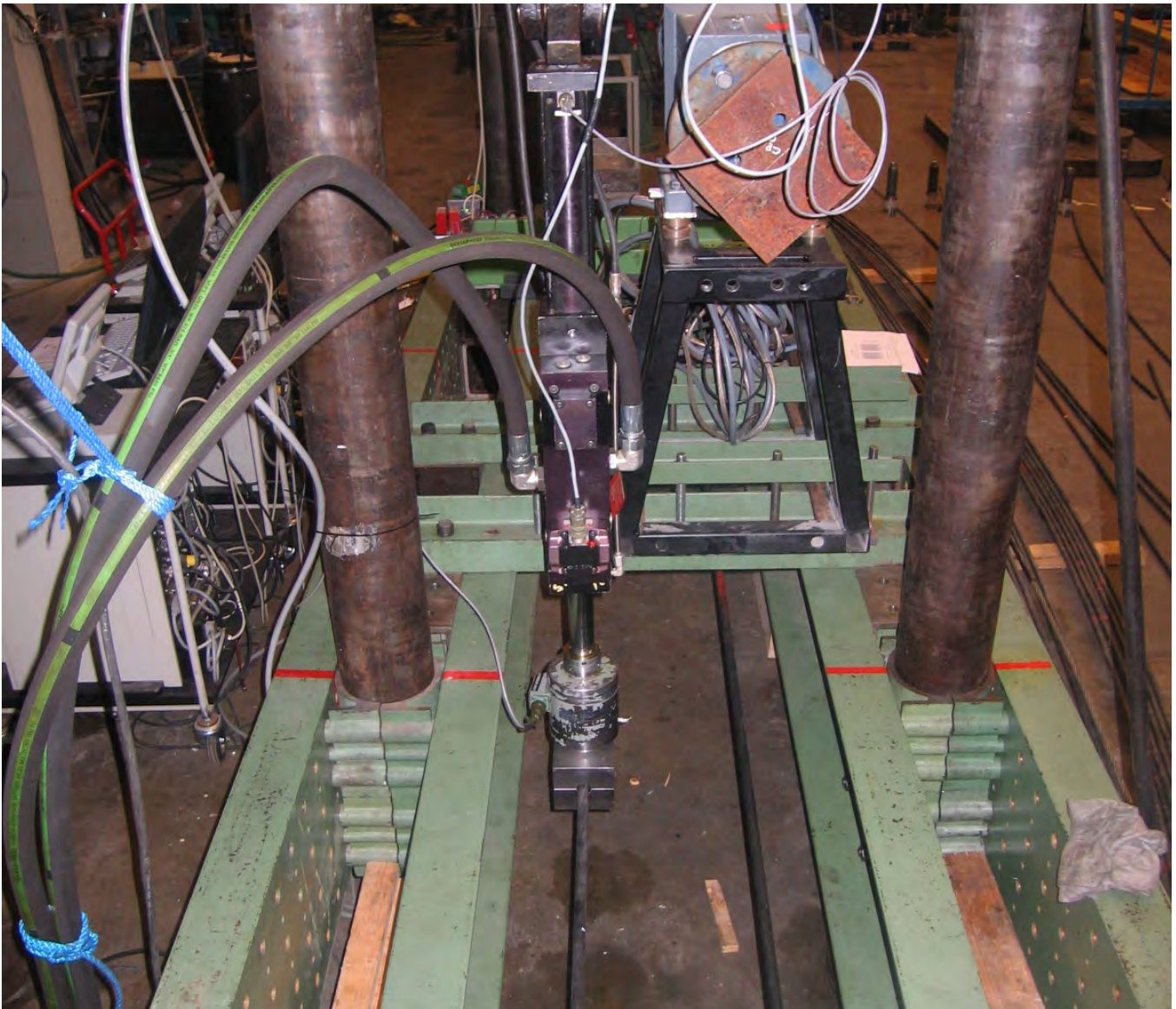

LEAK TIGHTNESS TEST

DSI anchorages are fully resistant to any infiltration of water. Tested according to PTI requirements:

- Subsequent to fatigue testing
- For 96 hours
- With a 3m water head

And tested according to fib and Setra requirements with:

- Up to 3m water head
- Several longitudinal and transverse load cycles
- Temperature cycle 20°C – 70°C



Cable Installation

DSI has developed various methods to optimize and simplify cable installation procedures depending on site specific space and time constraints.

If required, the complete cable can also be preassembled on the ground first.

- The outer sheathing is welded to its required length directly on site using heated tool welding and is then lifted into an inclined position
- Strands are uncoiled either from wooden reels or are provided reel-less. They are installed and stressed one by one using lightweight equipment
- Strand installation is performed using small winches or pushing devices
- Hardware configuration can be adjusted to site conditions to ensure a fast, customized solution that minimizes costs and cycle times
- Afterwards, strands are installed into the sheathing, and the complete cable is lifted into its final position
- Subsequently, all strands are stressed





Stressing

DYWIDAG stressing equipment is designed to ensure an economic and convenient installation process.

CONTEN STRESSING

The patented (EP2307637 B1; US8702066 B2) ConTen System uses a monojack that is hydraulically coupled with a control unit. The system is applicable both for DYNA Grip® and DYNA Bond® Stay Cable Systems.

- A special calculation method – developed by DSI – determines the force for the first strand and the corresponding forces for all subsequent strands
- This allows monitoring the stressing operation up to the required final cable force
- Every single strand is stressed individually
- Equal forces are achieved in all strands within one cable at the end of the stressing operation
- Influences of temperature and load changes during stressing are automatically eliminated

In case of very short strand elongation values or if the cable force needs to be adjusted, retensioning or releasing of the complete cable is possible by turning the ring nut. Special compact gradient jacks are available for this purpose

- Gradient jacks may be moved fully assembled or disassembled into their main components so that they fit even through small openings
- The same economic type of hydraulic pump can be used for both stressing systems. The pump is light, robust and has proven its reliability in many stay cable projects

CHANGE OF STRAND FORCE DEPENDING ON THE NUMBER OF STRESSED STRANDS

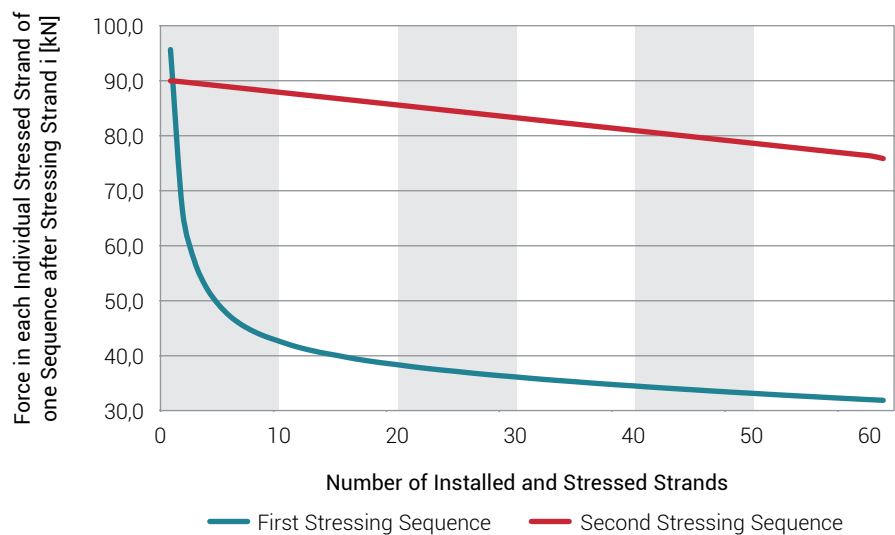

Standard Hydraulic Pump

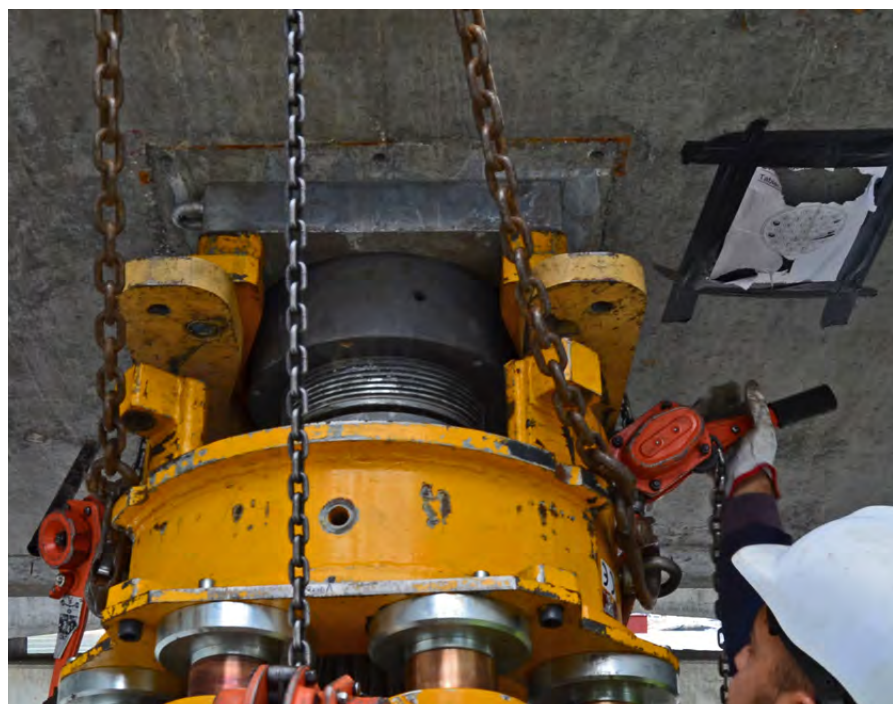

Gradient Jack



ConTen Jack

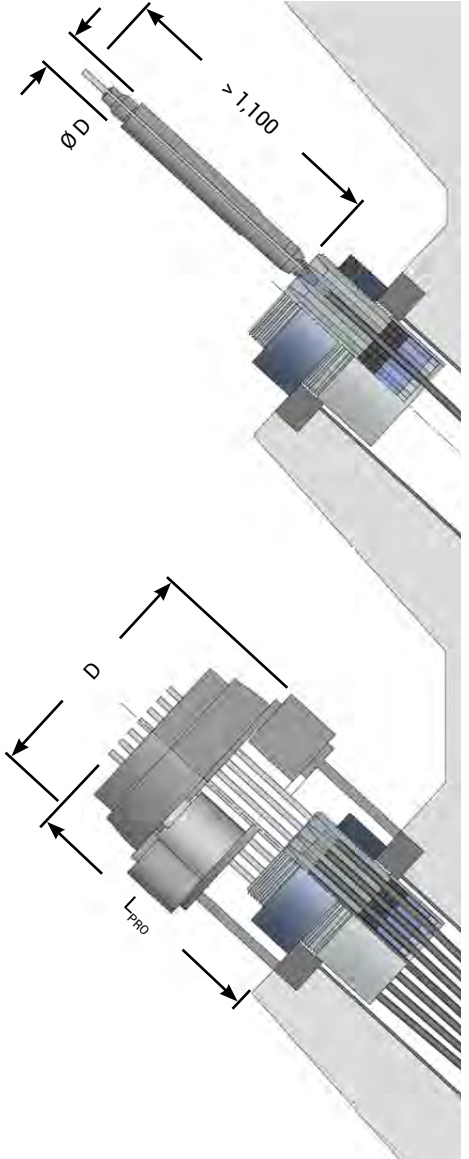

STRESSING EQUIPMENT

Jack Type	Cable Size	Type	Capacity	D	Minimum Strand Protrusion L_{PRO}	Weight
			[kN]	[mm]	[mm]	[kg]
ConTen Jack	All Types	180kN	182	$\varnothing 73$	1,100	19
Gradient Jacks (DYNA Grip® **)	12	C 27	3,500	560 x 610	610 *	400
	19					
	31					
	37	C 37	4,200	610 x 610	705 *	520
	55	C 61	6,800	700 x 700	750 *	700
	61					
	73	C 73	8,400	780 x 760	850 *	820
91	C 91	11,000	870 x 870	890 *	2,100	
109	C 127	16,000	1,160 x 1,050	910 *	3,100	
127						

* Measured from the top of the bearing plate

** For multistrand jacks for DYNA Bond®, please contact DSI

DYNA Force[®] Elasto-Magnetic Sensor

This system has been developed to measure or monitor forces within single strands of a stay cable during the construction progress as well as during the entire service life.

FUNCTIONAL PRINCIPLE

- The permeability of steel to a magnetic field changes with the stress level in the steel
- By measuring the change in a magnetic field, the magnitude of the stress in the steel element is obtained
- Data is gathered and elected by special system components
- Data can be handled using a conventional computer

SYSTEM COMPONENTS

- Portable Power Stress Unit
- Sensor with lead wire
- Multiplexer Box for connecting more than one sensor to the Power stress Unit at the same time
- Automated measurement on several sensors through multiplexer
- Transfer of data by WLAN connection or cellular wireless connection

SYSTEM ADVANTAGES IN COMPARISON TO OTHER MEASURING SYSTEMS

- The system cannot be overloaded
- Maintenance free
- No direct contact between the sensor and the strand/bar
- Resistant against dust and humidity
- Up to 2% of measurement accuracy



QUALITY ASSURANCE

- All DYNA Force® Sensors are professionally made in a quality controlled facility
- Every DYNA Force® Sensor is tested and individually packed and numbered at the DSI facility before it is sent to the job site

PRACTICAL APPLICATIONS

- When a DYNA Force® Sensor is installed on a strand, the force in it may be obtained directly by merely attaching the leads from the sensor to a portable Power Stress Unit
- No other equipment is needed
- DYNA Force® Sensors have been used in many bridge and building structures for the past several years
- Applicable not only for long-term monitoring, but also for supervision during the construction phase



Cable Inspection

VISUAL INSPECTION

Visual inspection is a key measure during cable maintenance and inspection.

- DYWIDAG visual inspection keeps traffic disturbances to a minimum
- Cameras are placed on an automotive cable robot that moves along the outer surface of the cable sheathing
- Cable surface is checked for damages or color changes
- Possible defects can be detected quickly
- Afterwards, detailed examinations can be limited to critical spots

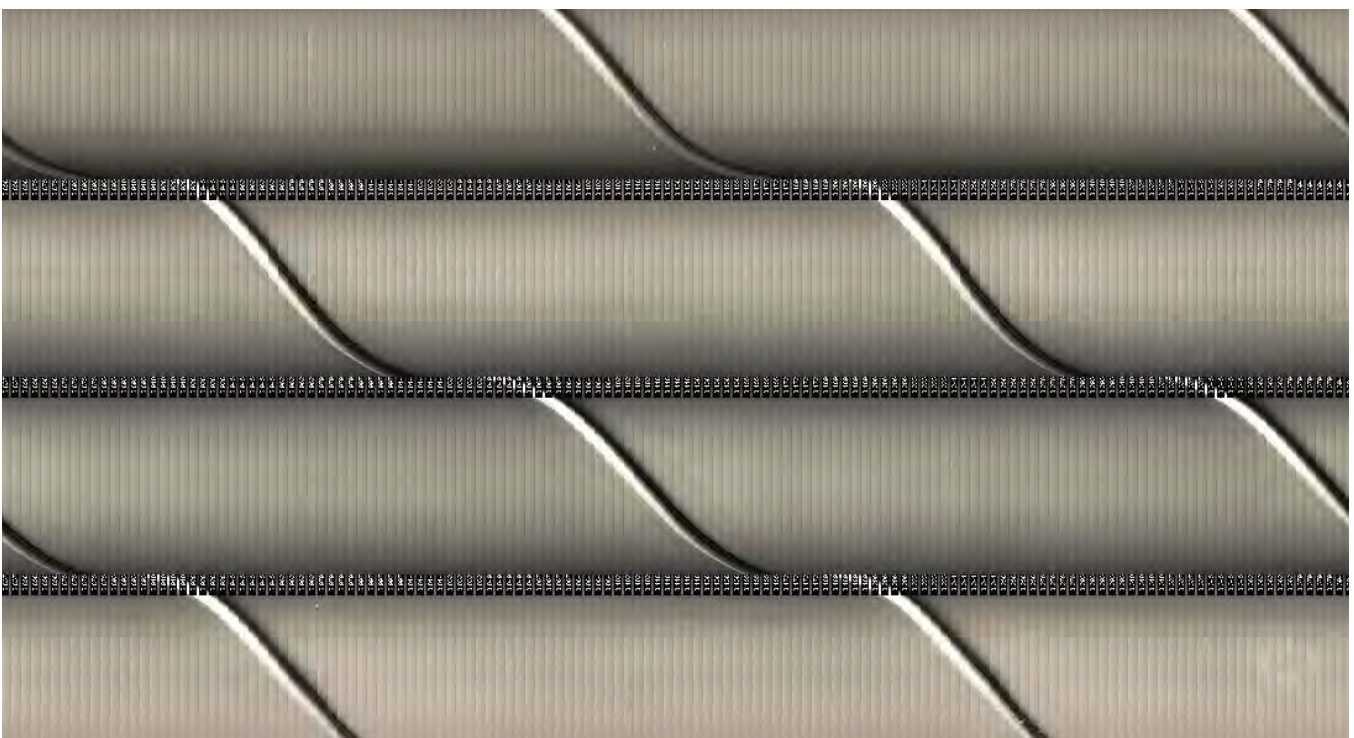
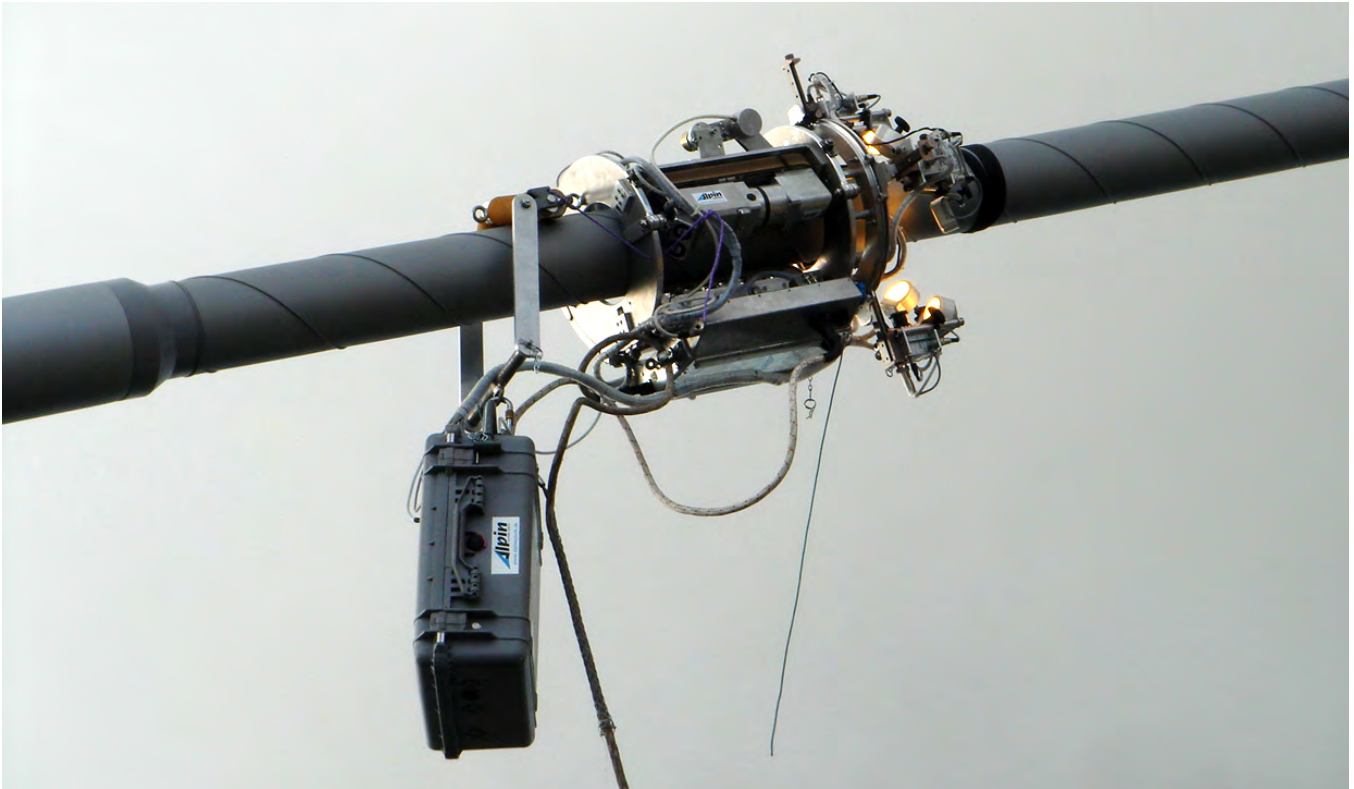

VIBRATION MEASUREMENT

Cable forces and cable damping values are very important both during and after construction as well as for monitoring. DSI offers vibration measurement for tension members to quickly and efficiently determine both cable forces and damping values.

- A 3-dimensional accelerometer, placed on the cable, registers its movements
- Measurement at one cable only takes a few minutes
- Each cable has an individual vibration characteristic depending on cable force, dimensions, the type of anchorage and on possible cable supports
- Eigenfrequencies and eigenmodes correspond to the vibration characteristics and can be calculated from the vibration measurement
- The obtained cable eigenfrequencies are used to calculate tensioning forces
- Damping values can be calculated by determining the decay of vibration amplitudes



MAGNETIC FLUX LEAKAGE INSPECTION

Magnetic flux leakage inspection is a non-destructive testing method that detects changing magnetic properties. DSI uses this method to determine corrosion, breaks or cuts to strands.

Magnetic flux leakage inspection is a very economic and fast testing procedure:

- The equipment can be adapted to fit different pipe diameters
- Only the deck anchorage needs to be accessible for mounting the equipment. The measuring equipment is moved by hoists and winches in the free cable length, thus minimizing traffic disturbances
- The whole strand bundle can be magnetized, which even allows checking strands on the inside

There is no need to remove HDPE sheathing: The equipment moves along the pipes, and the magnetic field permeates the HDPE sheathing.

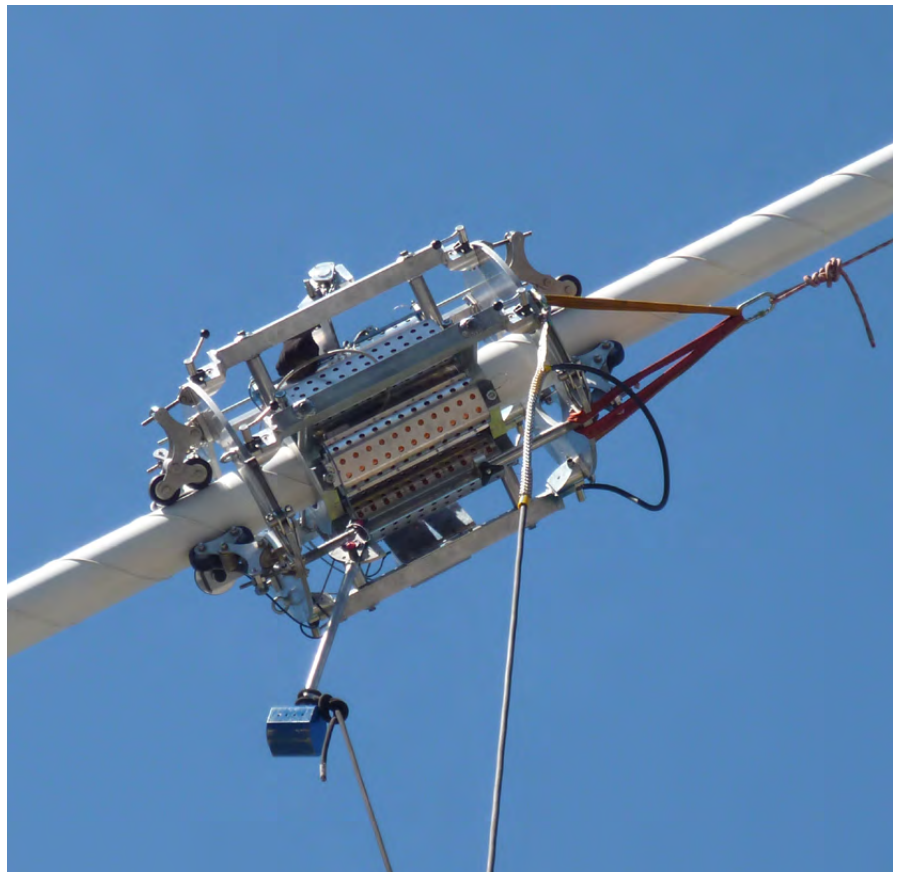

References

STAY CABLE REFERENCES

LARGE SCALE USE OF DYNA FORCE® SENSORS AND DYNA GRIP® STAY CABLES: ABRAHAM LINCOLN BRIDGE, LOUISVILLE, OH, USA

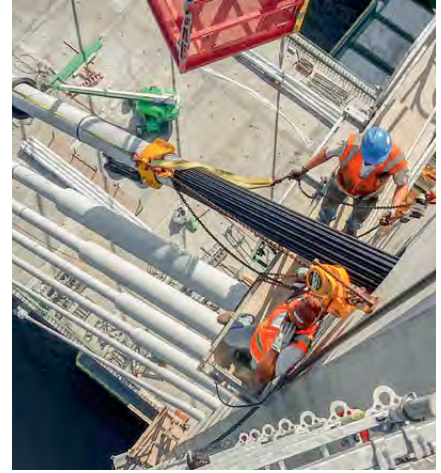

Owner Kentucky Transportation Cabinet (KYTC), USA +++
General Contractor Walsh Construction Company, USA +++
Contractor Milestone Contractors, L.P., USA +++
Engineering (Lead Design) Jacobs Engineering Group Inc., USA +++
Engineering (Design) COWI Bridge North America (formerly Buckland & Taylor Ltd.), Canada

DSI Units DYWIDAG-Systems International GmbH, BU Special Projects, Germany and DYWIDAG-Systems International USA Inc., BU Post-Tensioning, East, USA
DSI Construction Scope Production, supply and technical support
DYWIDAG Construction Products 88 Type DG-P37, DG-P48, DG-P55, DG-P73, DG-P91 and DG-P109 DYNA Grip® Stay Cables, 88 internal hydraulic dampers, 264 DYNA Force® Sensors with readout unit

THE TSUBASA BRIDGE: DYNA GRIP® STAY CABLES SUPPORT CAMBODIA'S LONGEST BRIDGE, NEAK LEOUNG, CAMBODIA



Owner Ministry of Public Works and Transport, Kingdom of Cambodia, Cambodia +++
General Contractor Sumitomo Mitsui Construction Co., Ltd., Japan +++
Architect Chodai Co., Ltd and Oriental Consultants Co., Ltd, Japan +++
Consulting Chodai Co., Ltd and Oriental Consultants Co., Ltd, Japan

DSI Unit and DSI Licensee DYWIDAG-Systems International GmbH, GBU, Germany; Sumitomo (SEI) Steel Wire Corp., Japan
DSI Construction and Sumitomo Scope Production, supply, installation, engineering services and technical support
DYWIDAG Construction Products 160 Type DG-P61, 55, 37, 31 and 22 DYNA Grip® Stay Cables; Type 12S 15.2, 3S 15.2, 19S 15.2, 5S 15.2, 7S 15.2 and 9S 15.2 DYWIDAG Strand Tendons; 32mm and 36mm Ø DYWIDAG Bar Tendons; Form Travellers

DYWIDAG POST-TENSIONING SYSTEMS AND DYNA GRIP® STAY CABLES FOR EWIJK CABLE STAYED BRIDGE, EWIJK, NETHERLANDS



Owner Rijkswaterstaat, Netherlands +++
General Contractor JV, consisting of Mobilis B.V., Netherlands, DYWIDAG Bau GmbH, Germany and Aannemingsmaatschappij Van Gelder B.V., Netherlands +++
Engineers Kinkel + Partner, Germany +++
Architects Paul Wintermans van Quist Wintermans Architecten, Netherlands

DSI Units DYWIDAG-Systems International GmbH, BU Post-Tensioning, Germany; DYWIDAG-Systems International B.V., Netherlands
DSI Construction Scope Production, supply, installation, tensioning and grouting
DYWIDAG Construction Products approx. 1,000t of prefabricated tendons as well as of tendons assembled on site, 8-0.62", 9-0.62", 19-0.62" and 22-0.62" with MA Anchorages and SD Plate Anchorages; 80 Type DG-P 73 and DG-P 91 DYNA Grip® Stay Cables

DYNA GRIP® STAY CABLE SYSTEM FOR NEW LANDMARK: THE ELBE BRIDGE, SCHOENEBECK, GERMANY



Owner Federal State of Saxony-Anhalt and city of Magdeburg, Germany +++
General Contractor Landesbetrieb Bau Sachsen-Anhalt, Germany +++
Contractor JV, consisting of Kirchner Holding GmbH and Donges SteelTec GmbH, both Germany +++
 Planner/Technical Development Leonhardt, Andrä und Partner Beratende Ingenieure VBI, GmbH, Germany

DSI Unit DYWIDAG-Systems International GmbH, Post-Tensioning, Germany
DSI Construction Scope Production, supply, technical support, magnetic flux leakage inspection and vibration measurement during compliance testing
DYWIDAG Construction Products approx. 340t of DYWIDAG Strand Tendons and of 36 Type DG-P 31, DG-P 37 and DG-P 55 DYNA Grip® Stay Cables; DYNA Force® Monitoring System

References

STAY CABLE BRIDGES

DSI SUPPLIES POST-TENSIONING SYSTEMS FOR A SELF-ANCHORED PEDESTRIAN SUSPENSION BRIDGE, SAN DIEGO, CA, USA



Owner City of San Diego, USA +++
Architect Safdie Rabines Architects, USA +++
General Contractor Reyes Construction, Inc., USA +++
Engineers T.Y. Lin International, USA

DSI Unit DYWIDAG-Systems International USA Inc., BU Post-Tensioning, West, USA

DSI Construction Scope Production, supply, installation, testing and grouting

DYWIDAG Construction Products 12-0.6", 19-0.6", 37-0.6", 37-0.62" and 43-0.6" DYWIDAG Main Stay Cable and DYWIDAG Strand Tendons incl. anchorages, accessories and stainless steel sheathing; DYNA Force® Sensors for load monitoring

DYNA GRIP® SYSTEM FOR SOUTH KOREA'S FIRST CURVED STAY CABLE BRIDGE, SAE POONG BRIDGE, YEOSU, SOUTH KOREA

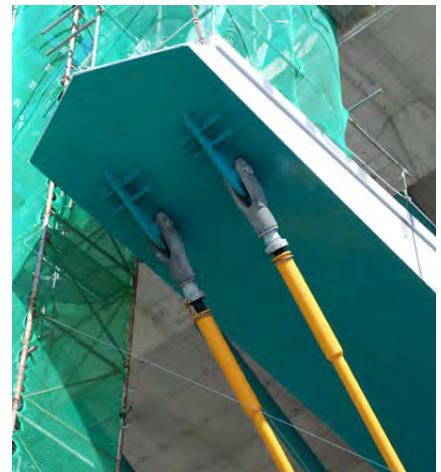

Owner Iksan Regional Construction & Management Administration, South Korea +++
General Contractor Daelim Consortium, South Korea +++
Design Chungbuk Engineering, South Korea +++
Consulting Daelim Industrial Co., LTD & Envico Consultants Co., LTD, both South Korea +++
Subcontractor for Stay Cable Installation BNG Consultants

DSI Unit and DSI Licensee DYWIDAG-Systems International GmbH, GBU, Germany; Sumitomo (SEI) Steel Wire Corp., Japan

DSI Construction and Sumitomo Scope Production and supply

DYWIDAG Construction Products 64 Type DG-P55 DYNA Grip® Stay Cables, 26 Type DG-P61 DYNA Grip® Stay Cables, 6 Type DG-P19 Stay Cables, 12 Type DG-P12 DYNA Grip® Stay Cables, 8 Type DG-P37 Stay Cables and 4 Type DG-P61 Stay Cables as well as of Clevis Anchorages

NEW PITT RIVER STAY CABLE BRIDGE IN CANADA SOLVES LONG TERM TRAFFIC CONGESTION PROBLEM, PITT MEADOWS, BC, CANADA

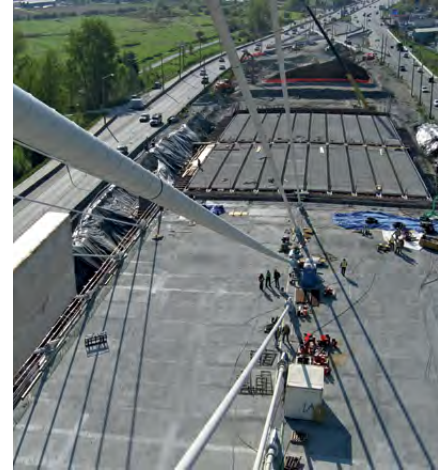

Owner British Columbia Provincial Government, Vancouver, Canada +++
General Contractor Peter Kiewit Sons, Inc., Saskatoon, Canada +++
Consultant MMM Group, Thornhill, Canada +++
Design Associated Engineering (B.C.) Ltd., Vancouver, Canada; International Bridge Technologies, Inc, Coquitlam, Canada (Detailed design and construction engineering for main bridge)

DSI Unit DSI Canada Ltd., Western Division, Surrey, Canada
DSI Construction Scope Production, supply and technical assistance
DYWIDAG Construction Products 96 Type DG-P31 and DG-P61 DYNA Grip® Stay Cables; External Damper; rental of equipment

NEW GENERATION OF STAY-CABLE BRIDGES INCORPORATING DSI EXPERTISE, PENOBSCOT NARROWS BRIDGE, BUCKSPORT, ME, USA



Owner Maine Department of Transportation, USA +++
General Contractor JV consisting of Cianbro and Reed & Reed, USA +++
Engineer Figg Bridge Engineers, Inc., Tallahassee, Florida, USA

DSI Unit DSI USA, BU Post-Tensioning, USA
DSI Construction Scope Production, supply and technical assistance
DYWIDAG Construction Products 80 total DYNA Grip® Stay Cables with epoxy-coated strands, HDPE Ducts with nitrogen filling, 4 form travellers, DYNA Force® Sensors for load monitoring

References

EXTRADOSED BRIDGES

DYNA® LINK PERMITS ECONOMIC CONSTRUCTION, CHAO PHRAYA RIVER CROSSING, NONTHABURI, THAILAND



Owner Ministry of Transport, Department of Rural Roads, Thailand +++

General Contractor JV ITD-SMCC, consisting of Italian-Thai Development Public Company Limited, Thailand and Sumitomo Mitsui Construction Co., Ltd., Japan +++

Architect Epsilon Co., Ltd., Thailand

DSI Unit DYWIDAG-Systems International GmbH, GBU, Germany

DSI Construction Scope Development, production, supply and supervision

DYWIDAG Construction Products 48 Type DG-P 31 DYNA Grip® Stay Cables, 48 Type DG-P 55 DYNA Grip® Stay Cables, 48 DYNA® Link Anchor Box Structures

A CASE FOR DYNA GRIP®: TROIS BASSINS BRIDGE, LA RÉUNION ISLAND

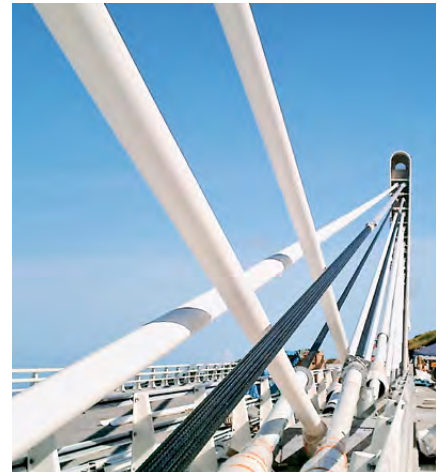

Contracting Authority Région Réunion-Direction d'Opération Route des Tamarins, Saint Denis, La Réunion +++

Prime Contractor ARCADIS ESG, Sèvres, France; Cotéba, La Plaine Saint-Denis, France +++

Architect Strates/Berlottier Architectes, Bourg-en-Bresse, France +++

General Contractor Eiffage TP, Neuilly sur Marne, France ; Matière, Groupe Razel SA, France

DSI Units DSI Group Headquarter Operations, Germany; DSI France SAS, France

DSI Construction Scope Production, supply and installation

DYWIDAG Construction Products 34 pieces of DYNA Grip® DG-P37 anchorages; supply of 352 DYWIDAG Post-Tensioning anchorages types MA 6812 and MA 6819 and 36 anchorages VC 6819 for external Post-Tensioning; Fire Protection over the full cable length

**DYNA GRIP® STAY CABLES FOR GUJARAT'S FIRST EXTRADOSED BRIDGE:
THE 3RD NARMADA BRIDGE, BHARUCH, INDIA**



Owner National Highway Authority of India, India +++
General Contractor Larsen & Toubro Limited, India +++
Consulting Engineers Precast Bridge Tech. Co., Ltd., Thailand +++
Consulting JV, consisting of Yogma Engineering co., Ltd., Korea and Feedback Ventures Pvt., Ltd., India

DSI Unit/Subcontractor DSI-BRIDGECON India Pvt. Ltd., India
DSI-BRIDGECON Scope Design and supply
DYWIDAG Construction Products 216 Type DG-P31, DG-P37, DG-P43 and DG-P55 DYNA Grip® Stay Cables, DYNA® Link Anchor Box System, DYNA Force® Sensors

**DYWIDAG SYSTEMS SECURE LONGEST EXTRADOSED BRIDGE IN
EUROPE: POVAŽSKÁ BYSTRICA BRIDGE, SLOVAKIA**

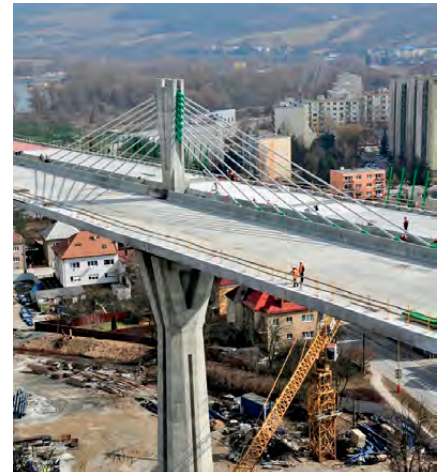

Owner Federal State of Saxony-Anhalt and city of Magdeburg, Germany +++
General Contractor Landesbetrieb Bau Sachsen-Anhalt, Germany +++
Contractor JV, consisting of Kirchner Holding GmbH and Donges SteelTec GmbH, both Germany +++
Planner/Technical Development Leonhardt, Andrä und Partner Beratende Ingenieure VBI, GmbH, Germany

DSI Licensee Doprastav, Bratislava, Slovakia
Doprastav Scope Supply and installation
DYWIDAG Construction Products 56 saddles and 112 DG-P 37 anchorages; rental of equipment

References

ARCHED BRIDGES

NEW LAKE CHAMPLAIN ARCH BRIDGE ENSURES EFFICIENT TRANSPORT CONNECTION, CROWN POINT, NY, USA



Owner New York State Department of Transportation +++
General Contractor Flatiron Constructors, Inc., USA +++
Architect HNTB Corporation, USA +++
Consulting Engineers HNTB Corporation, USA

DSI Unit DYWIDAG-Systems International USA Inc., BU Post-Tensioning, East, USA
DSI Construction Scope Production, supply and installation
DYWIDAG Construction Products 64 DYNA Grip® Stay Cables, Clevis Anchorages and post-tensioning systems for the bridge deck

A BRIDGE LEADING THE WAY INTO THE FUTURE: THE GAJO ARCH BRIDGE, SOUTH KOREA



Owner Cabletek, Seoul, Korea +++ **General Contractor** Hanjin Heavy Industries & Construction Co. Ltd., Korea

DSI Units DSI Group Headquarter Operations, Munich, Germany and DSI Korea Co. Ltd., Seoul, Korea
DSI Construction Scope Production, supply, installation
DYWIDAG Construction Products 160 DYNA Grip® DG-P12 anchorages

SPECIAL APPLICATIONS

DYNA GRIP® SYSTEM STABILIZES FRANCE'S FIRST MOVABLE STADIUM ROOF, LILLE, FRANCE

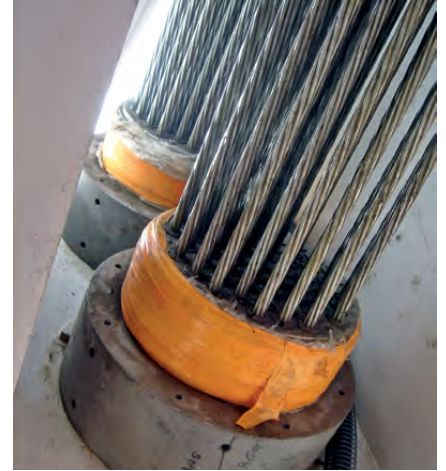

Owner Communauté Urbaine de Lille Métropole, France +++
General Contractor Elisa (Eiffage Lille Stadium Aréna), France +++
Contractor EIFFAGE Travaux, France +++ Subcontractor Eiffel, France +++
Architect Pierre Ferret; Valode & Pistre, both France +++
Consulting Engineers Iosis, Arcora, Froclum, all of them France +++
Consulting Socotec, France Engineers Greisch, Belgium

DSI Unit DSI France SAS, France

DSI Construction Scope Production and supply

DYWIDAG Construction Products 0.62", St 1860 Stay Cable Strands, 8 deviation saddles for 55 strands, 6 Type DG-P 37 DYNA Grip® Anchorages and 4 Type DG-P 55 DYNA Grip® Anchorages as well as DYNA Force® Sensor

TENSIONING FOR HIGH TENSION: DYNA GRIP® STAY CABLES STABILIZE WIND POWER STATION, VAASA, FINLAND



Owner Mervento Oy, Finland

DSI Units DYWIDAG-Systems International GmbH and DYWIDAG-Systems International GmbH, Headquarter Operations, both Germany

DSI Construction Scope Production, supply, installation and technical service

DYWIDAG Construction Products 6 Type DG-P 37 DYNA Grip® Stay Cables and 12 DYWIDAG Strand Anchors, 22 strands; rental of equipment

AUSTRALIA

DYWIDAG-Systems International Pty. Ltd.
25 Pacific Highway
Bennetts Green, NSW 2290
Australia
Phone +61-2-49 48 90 99
E-mail civilsales@dywidag.com.au
www.dsicivil.com.au

AUSTRIA

DSI Underground Austria GmbH
Alfred-Wagner-Strasse 1
4061 Pasching/Linz
Austria
Phone +43-7229-610 49-0
E-mail info.austria@dsiunderground.at
www.dsiunderground.at

BELGIUM

DYWIDAG-Systems International N.V.
Philipssite 5, bus 15
Ubicenter
3001 Leuven
Belgium
Phone +32-16-60 77 60
E-mail info.be@dywidag-systems.com
www.dywidag-systems.com/emea

BRAZIL

PROTENDIDOS DYWIDAG Ltda.
Rua Iaiá, 150 – 10º andar – Cj. 102
Itaim Bibi
04542-060-São Paulo/SP
Brazil
Phone +55-11-21 31 37 00
E-mail ventas@dywidag.com.br
www.dywidag.com.br

DSI PREPRON

Rua Virgília Maria de Oliveira Freitas, 110
Distrito Industrial II CEP. 19570-000
Regente Feijó – SP
Brazil
Phone +55-18-32 79 31 51
E-mail prepron@prepron.com.br
www.dsi-prepron.com.br

CANADA

DSI Canada Civil Ltd.
37 Cardico Drive
Stouffville, ON L4A 2G5
Canada
Phone +1-905-888 8988
E-mail ecd@dsiamerica.com
www.dsicanada.ca

DSI Canada Civil Ltd.

19433 – 96th Avenue, Suite 103
Surrey, BC V4N 4C4
Canada
Phone +1-604-888 8818
E-mail wcd@dsiamerica.com
www.dsicanada.ca

CHILE

DSI-DYWIDAG-SYSTEMS Construcción SpA
Av. Presidente Riesco 5335
piso 9, oficina 909
Las Condes, Santiago de Chile
Chile
Phone +56-2-2714 3974
E-mail informaciones.chile@systemasdywidag.com
www.dywidag.cl

CHINA

DYWIDAG-Systems International Far East Ltd.
Unit 905-907
9/F, Prosperity Millennia Plaza
663 King's Road
North Point
Hong Kong
Phone +852-28-33 19 13
E-mail dsihk@dsife.com.hk
www.dywidag-systems.com/emea

COLOMBIA

DSI Colombia S.A.S.
Carrera 43A No. 8 sur – 15 Oficina 403
Edificio Torre Oviedo
Medellín, Colombia
Phone +57-4-403 12 00
E-mail ventas.colombia@sistemasydywidag.com
www.dsi-colombia.co

CROATIA

PRESS-KON
Obala Hrvatskog
narodnog preporoda 6
21000 Split
Croatia
Phone +385-21-34 27 66
E-mail info@dywidag-systems.com

Czech Republic
DYWIDAG-Systems International
Jilemnického 29/46
772 00 Olomouc-Nedvěži
Czech Republic
Phone +420-585-94 10 76
www.dywidag-systems.com/emea

EGYPT

MISR DYWIDAG
20 Haroun Street
El Dokki
Giza
Egypt
Phone +20-2-37 61 48 69
E-mail mail@misrwywidag.com

FINLAND

TENSICON OY
Rattitie 17
007700, Helsinki 77
Finland
Phone +358-500-40 64 38
www.tensicon.fi

FRANCE

DSI France SAS
Rue de la Craz
Z.I. des Chartinières
01120 Dagneux
France
Phone +33-4-78 79 27 82
E-mail dsi.france@dywidag-systems.fr
www.dywidag-systems.fr

GERMANY

DYWIDAG-Systems International GmbH
Max-Planck-Ring 1
40764 Langenfeld
Germany
Phone +49-2173-79 02-0
E-mail suspa@dywidag-systems.com
www.dywidag-systems.de

DYWIDAG-Systems International GmbH

Schuetzenstrasse 20
14641 Nauen
Germany
Phone +49-3321-44 18-0

DYWIDAG-Systems International GmbH

Siemensstrasse 8
85716 Unterschleissheim
Germany
Phone +49-89-30 90 50-100
E-mail dsihv@dywidag-systems.com
www.dywidag-systems.com/emea

GREECE

Post-Tensioning Systems
Kostantinos Zervas
34th Sintagmatos Pezikon 5
Pireas TK 18532 Athens
Greece
Phone +30-213-0227 363

INDIA

DSI-BRIDGECON India Pvt. Ltd.
265, Okhla Industrial Estate,
Phase 3
110020 New Delhi
India
Phone +91-11-41 83 20 60-61
E-mail info@dsi-bridgecon.com
www.dsi-bridgecon.com

INDONESIA

PT DELTA SYSTECH INDONESIA
Wisma Ritra 2nd Floor
Jl. Warung Buncit Raya No. 6
Jakarta – 12740
Indonesia
Phone +62-21-797 02 89
E-mail prestress@dsi-indonesia.co.id

ISRAEL

EVEN GEV Ltd.
Emanuel Building
31 Ha'Barzel Str.
Ramat Ha'Hayal
Tel Aviv 69710
Israel
Phone +972-77-501 00 56

ITALY

DYWIT S.P.A.
Viale Europa 72 Strada A 7/9
20090 Cusago (MI)
Italy
Phone +39-02-901 65 71
E-mail info@dywit.it
www.dywit.it

JAPAN

SUMITOMO ELECTRIC INDUSTRIES, LTD.
Sales Department
Special Steel Wire Division
1-1-1, Koya-kita Itami,
Hyogo, 664-0016
Japan
Phone +81-72-771-0966
www.sei-ssw.co.jp

KOREA

DYWIDAG-Systems Korea Co. Ltd.
5th Floor, Spring Morning B/D
8, Mabang-ro, Seocho-gu
Seoul 06778
Korea
Phone +82-2-34 72 01 41
E-mail dywidagkor@gmail.com
www.dsikorea.co.kr

LEBANON

SOPREL Liban SAL
Liban Cable Street
Halate
Lebanon
Phone +961-9-44 88 60
E-mail contact@soprel-liban.com

LITHUANIA

Delta Nova
Užupio g. 30
LT-01203 Vilnius
Lithuania
Phone +370-5272-53 08
E-mail info@deltanova.lt
www.deltanova.lt

NETHERLANDS

DYWIDAG-Systems International B.V.
Veilingweg 2
5301 KM Zaltbommel
Netherlands
Phone +31-418-57 89 22
E-mail emai.nl@dywidag-systems.com
www.dywidag-systems.nl

NIGERIA

PTSL Post Tensioning Services Limited
167C Isale Eko Av
Dolphin Estate
Ikoyi, Lagos
Nigeria
Phone +234-80-72 72 22 22
E-mail info@pts-l.com
www.pts-l.com

NORWAY

Dywidag Norge AS
Norvald Strands veg 21
2212 Kongsvinger
Norway
Phone +47-62-88 86 80
E-mail adm@dywidag-norge.no
www.dywidag-norge.no

PERU

DSI - DYWIDAG CONSTRUCCIÓN PERU S.A.C.
Calle Uno Oeste 0061 Of. 103
San Isidro-Lima 1
Peru
Phone +51-1-224 54 54
E-mail ventas.peru@sistemasdywidag.com
www.dsi-peru.com

PHILIPPINES

GCS Godel Concrete & Systems Inc.
2001 Mabini St. Malate
Manila
1004 Metro Manila
The Philippines
Phone +63-917-89 18 092
E-mail tkrause@gcs.com.ph
www.gcs.com.ph

POLAND

DYWIDAG-Systems International Sp. z o.o.
ul. Bojowników o Wolnosć i Demokrację,
38/121
41-506 Chorzów
Poland
Phone +48-32-241 09 98
E-mail dsi-polska@dywidag-systems.com
www.dywidag-systems.pl

PORTUGAL

DYWIDAG SISTEMAS CONSTRUCTIVOS, SA
Rua D. Manuel, n.º 24 A
Quinta da Parreirinha
2695-003 Bobadela (Loures)
Portugal
Phone +351-21-892 28 90
E-mail dywidag@dywidag-sistemas.com

QATAR

DSI Middle East W.L.L. (Formerly QACS)
Al Shoumoukh Towers 11th Floor
Street 231 Building no 58
Area no 23, Suhaim Bin Hamed Doha
P.O.Box 24893
Doha / Qatar
Phone +974-44-58 04 11
www.dsi-middleeast.com

RUSSIA

DSI-PSK 000
Joint Venture
Leninsky prospekt,
d. 105, korp. 4
Moscow 119421
Russia
Phone +7-495-234 25 02
www.psk-holding.ru

SAUDI ARABIA

DYWIDAG-Systems International
Saudi Arabia, LLC
P.O. Box 64014
Riyadh-Olaya 11536
Saudi Arabia
Phone +966-11-455 31 23
E-mail dsihv@dywidag-systems.com
www.dywidag-systems.com/emea

SERBIA / MONTENEGRO

EnCon d.o.o
12 Vlakoviceva Street
11000 Belgrade
Serbia
Phone +381-11-32 40 294
E-mail iv.encon@eunet.rs

SINGAPORE

UTRACON STRUCTURAL SYSTEMS PTE LTD
5 Joo Koon Way
Singapur 628944
Phone +65-64-15 30 78
E-mail utracon@utracon.com
www.utracon.com

SLOVAKIA

Doprastav, a.s.
Závod Prefa
Drieňová 31
821 01 Bratislava
Slovakia
Phone +421-2-48 271 130
E-mail bratislava@doprastav.sk
www.doprastav.sk

SOUTH AFRICA

Amsteele Systems
Unit 20, Lothlorien Industrial Park
Tedstone Road, Wadeville
Albemarle 1410
South Africa
Phone +27-11-827 6721

SPAIN

DYWIDAG SISTEMAS CONSTRUCTIVOS, S.A.
Avd/de la Industria, 4
Pol. Ind. la Cantuena
28947 Fuenlabrada (Madrid)
Spain
Phone +34-91-642 20 72
E-mail dywidag@dywidag-sistemas.com
www.dywidag-sistemas.com

SWITZERLAND

SpannStahl AG
Industriegebiet
Waesserstrasse 29
8340 Hinwil/ZH
Switzerland
Phone +41-44-9 38 97 97
E-mail info@spannstahl.ch
www.spannstahl.ch

TAIWAN

DYWITECH Co. Ltd.
13th Fl.-3, No. 163, Sec. 1, Keelung Road
Taipei 110
Taiwan, R.O.C.
Phone +886-2-27 48 10 76

THAILAND

Span Systems International Co., Ltd.
71/1 Soi Charoenpom 2, Pradiphat Road,
Samsen-nai, Phayathai,
Bangkok 10400
Thailand
Phone +66-87-48 67 777
E-mail spansystems@span-systems.com

TURKEY

DIVIGER Yapi Teknoloji A.S.
Yildiz Posta Cad.
Ayildiz Sitesi 30/15
34349 Istanbul-Gayrettepe
Turkey
Phone +90-212-234 56 12
E-mail diviger@diviger.com

UNITED ARAB EMIRATES (U.A.E.)

DYWIDAG-Systems International
PO Box 234085
Dubai Residential Oasis Building,
Block 2, Flat 208,
Damascus Street,
Al Qusais Industrial 2,
Dubai, United Arab Emirates
Phone +971-5555-00 275
E-mail dsihv@dywidag-systems.com
www.dywidag-systems.com/emea

UNITED KINGDOM

DYWIDAG-Systems International Ltd.
Northfield Road
Southam, Warwickshire, CV47 0FG
Great Britain
Phone +44-1926-81 39 80
E-mail sales@dywidag.co.uk
www.dywidag.co.uk

USA

DYWIDAG-Systems International USA Inc.
320 Marmon Drive
Bolingbrook, IL 60440
USA
Phone +1-630-739 1100
E-mail dsiamerica@dsiamerica.com
www.dsiamerica.com

DYWIDAG-Systems International USA Inc.

2154 South Street
Long Beach, CA 90805
USA
Phone +1-562-531 6161
E-mail dsiamerica@dsiamerica.com
www.dsiamerica.com

ARGENTINA
AUSTRALIA
AUSTRIA
BELGIUM
BOSNIA AND HERZEGOVINA
BRAZIL
CANADA
CHILE
CHINA
COLOMBIA
COSTA RICA
CROATIA
CZECH REPUBLIC
DENMARK
EGYPT
ESTONIA
FINLAND
FRANCE
GERMANY
GREECE
GUATEMALA
HONDURAS
HONG KONG
INDIA
INDONESIA
IRAN
ITALY
JAPAN
KOREA
LEBANON
LUXEMBOURG
MALAYSIA
MEXICO
NETHERLANDS
NIGERIA
NORWAY
OMAN
PANAMA
PARAGUAY
PERU
POLAND
PORTUGAL
QATAR
RUSSIA
SAUDI ARABIA
SINGAPORE
SOUTH AFRICA
SPAIN
SWEDEN
SWITZERLAND
TAIWAN
THAILAND
TURKEY
UNITED ARAB EMIRATES
UNITED KINGDOM
URUGUAY
USA
VENEZUELA

North America

DYWIDAG-Systems International USA Inc.
320 Marmon Drive
Bolingbrook, IL 60440
USA
Phone +1-630-7 39 11 00
E-mail dsiamerica@dsiamerica.com
www.dsiamerica.com

South America

PROTENDIDOS DYWIDAG Ltda.
Rua Iaiá, 150 – 10º andar - Cj.102
Itaim Bibi
04542-060-São Paulo/SP
Brazil
Phone +55-11-21 31 37 00
E-mail vendas@dywidag.com.br
www.dywidag.com.br

EMEA

DYWIDAG-Systems International GmbH
Siemensstrasse 8
85716 Unterschleissheim
Germany
Phone +49-89-30 90 50-100
E-mail dsihv@dywidag-systems.com
www.dywidag-systems.com/emea

APAC

DYWIDAG-Systems International Pty. Ltd.
25 Pacific Highway
Bennetts Green, NSW 2290
Australia
Phone +61-2-49 48 90 99
E-mail civilsales@dywidag.com.au
www.dsicivil.com.au

Please Note:

This brochure serves basic information purposes only. Technical data and information provided herein shall be considered non-binding and may be subject to change without notice. We do not assume any liability for losses or damages attributed to the use of this technical data and any improper use of our products. Should you require further information on particular products, please do not hesitate to contact us.