

Part #109998-001

# Product Manual:

Model #1325D  
Axial Ventilator



  
**PELSUE**<sup>®</sup>  
*ISO 9001 Certified*

**T.A. Pelsue Company**  
2500 South Tejon Street  
Englewood, Colorado, USA 80110  
Tel. 800-525-8460 or 303-936-7432  
Fax. 303-934-5581  
Internet: [www.pelsue.com](http://www.pelsue.com)  
Email: [sales@pelsue.com](mailto:sales@pelsue.com)



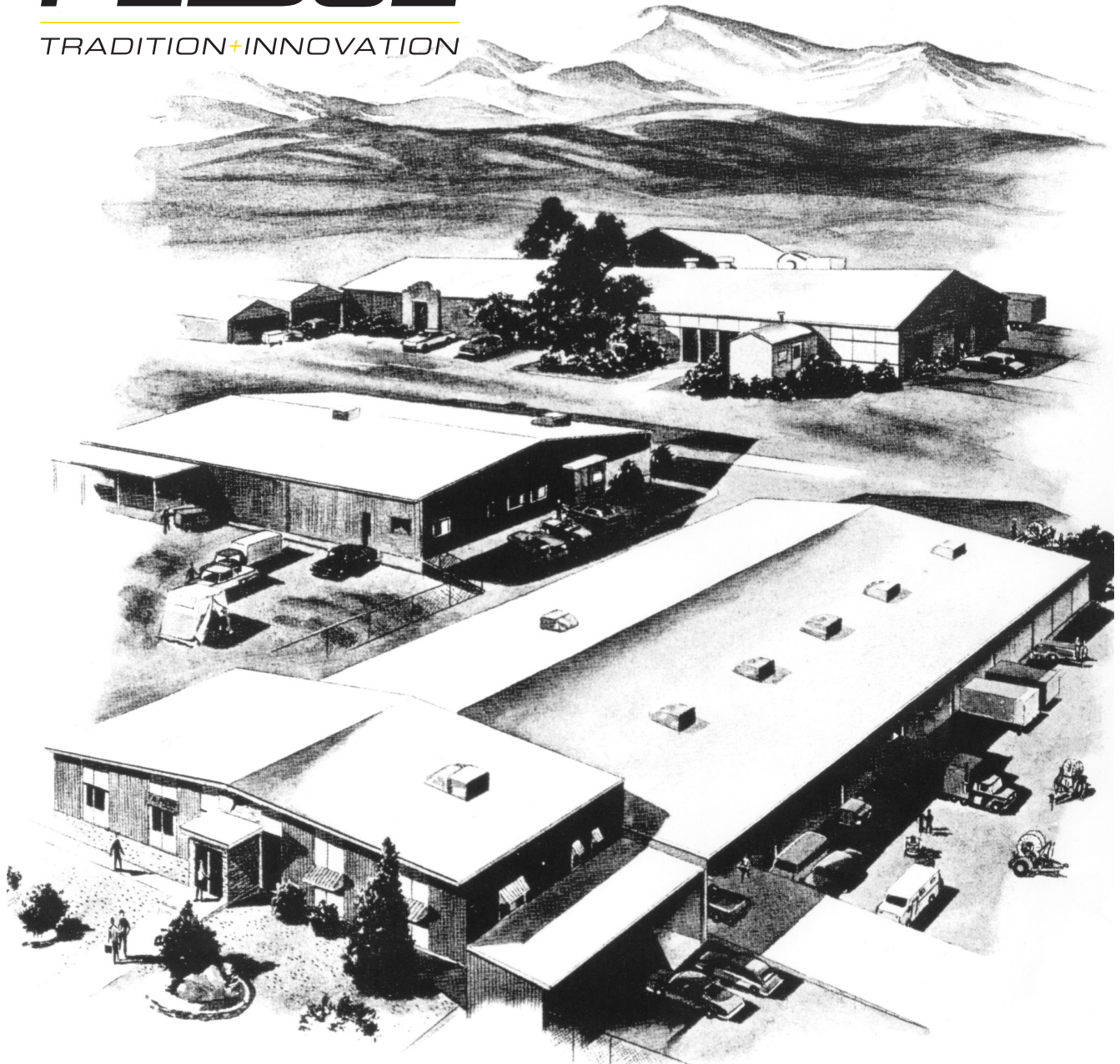

Since our inception in 1963 – the T.A. Pelsue Company has designed and manufactured high quality equipment to improve the personnel efficiency and working conditions in various underground, confined, and outdoor areas. Founded by T. Allen Pelsue, the company has established a continuing reputation for excellence in the production of fine products for a broad spectrum of industry throughout the world.

Now, in our second generation of family direction, continued commitment to innovation and quality makes Pelsue a leading source of equipment for many types of confined spaces. We specialize in safety, retrieval, fall arrest, ventilation, cable placing, splicing, and maintenance nationally and abroad. With more than 70,000 square feet of facilities available, Pelsue continues the dedication that has made us pre-eminent in this field.

# Table of Contents

---

| <b>Section</b>   | <b>Description</b>                                  | <b>Page #</b> |
|------------------|---|---------------|
| <b>1.0</b> ..... | <b>General Information</b> .....                    | <b>5</b>      |
| 1.1              | Quality Policy                                      |               |
| 1.2              | Pelsue Product Warranty                             |               |
| <b>2.0</b> ..... | <b>Introduction &amp; Product Information</b> ..... | <b>7</b>      |
| 2.1              | Serial Number                                       |               |
| <b>3.0</b> ..... | <b>Configuration &amp; Assembly</b> .....           | <b>8</b>      |
| 3.1              | Parts Diagram & List                                |               |
| 3.2              | Wiring Diagram                                      |               |
| <b>4.0</b> ..... | <b>Safety</b> .....                                 | <b>11</b>     |
| 4.1              | Safety Alert Symbol                                 |               |
| 4.2              | General Safety Information                          |               |
| <b>5.0</b> ..... | <b>Product Operation</b> .....                      | <b>13</b>     |
| 5.1              | Product Description & Capabilities                  |               |
| 5.2              | Start-Up & Operating Procedures                     |               |

# 1.0 General Information

---

## 1.1 Quality Policy

---

### **T.A. Pelsue Company**

#### **Quality Policy**

OUR GOAL IS THE PURSUIT OF NEVER-ENDING IMPROVEMENT IN PRODUCT QUALITY AND BUSINESS SYSTEMS.

METHODS TO BE EMPLOYED IN ATTAINING THIS GOAL WILL INCLUDE NEW PRODUCT QUALITY PLANNING, EMPLOYEE TRAINING, AND UTILIZATION OF EMPLOYEE INVOLVEMENT GROUPS TO SOLVE PROBLEMS.

IN AN INCREASINGLY COMPETITIVE MARKETPLACE, ENSURING CUSTOMER SATISFACTION IS ONE OF THE DIFFERENTIATORS THAT SETS YOU APART FROM THE PACK AND YIELDS A COMPETITIVE ADVANTAGE.

THEREFORE, WE WILL SUPPORT TOTAL CUSTOMER SATISFACTION BY IMPLEMENTING THE **ISO 9001 QUALITY SYSTEM** AND PROVIDING THE NECESSARY ATMOSPHERE AND TRAINING TO NURTURE THIS CONCEPT THROUGHOUT OUR ORGANIZATION.

WE WILL MAKE EVERY BUSINESS DECISION AS THOUGH THE QUALITY OF THE PART OR SERVICE PROVIDED WAS DESTINED FOR OUR OWN OR OUR FAMILY'S USE. WE WILL ALWAYS THINK **QUALITY FIRST**.

EVERY T.A. PELSUE COMPANY EMPLOYEE IS EXPECTED TO COMMIT TO THIS PHILOSOPHY IN THE PERFORMANCE OF HIS OR HER DAILY TASKS.

#### **QUALITY FIRST!**

T.A. PELSUE COMPANY SENIOR MANAGEMENT TEAM

## 1.2 - Pelsue Product Warranty

### PELSUE PORTABLE PRODUCT WARRANTY

- Pelsue products are designed and engineered to perform as stated in published specifications. Quality materials and workmanship are used in the manufacture of this product. With regular maintenance and proper care, Pelsue equipment provides many trouble free hours of operation.
- The T.A. Pelsue Company warrants to the buyer that material furnished will conform to specifications and will be free from defects in material and workmanship from the date of shipment to the original buyer, for the period listed by product description on the reverse side of this warranty statement.
- In the event of failure of any components of a Pelsue product within the warranty period, service must be pre-approved by the T.A. Pelsue Company and service must be performed by the T.A. Pelsue Company Parts and Service Department in Englewood Colorado, or at the option of T.A. Pelsue Company, service may be performed at any designated service center, which may include any authorized service center for the component manufacture.
- Damage or failure due to misuse, mishandling, or unauthorized modifications will not be covered by this warranty. Unless otherwise agreed, the T.A. Pelsue Company shall repair or replace the defective components within (30) calendar days of notice of failure. T.A. Pelsue Company's obligation hereunder, shall be limited to the repair or replacement of the product or component as set forth above, and shall not include any liability whatsoever for damages caused by such failure, including but not limited to consequential or incidental damages flowing from use or lack of use of product.
- Any replacement, repair, modification, installation or other service performed by the T.A. Pelsue Company shall be warranted by the remainder of the unexpired period of the warranty, or for a period of (90) calendar days, whichever is longer.
- All materials or parts returned for credit or warranty shall be returned only with prior approval, and will be subject to factory inspection before credit is allowed. Parts claimed defective will be replaced upon request and will be invoiced as purchased, subject to credit when the parts claimed to be defective have been received and examined by the factory.
- This warranty is expressly in lieu of all other warranties expressed or implied, including any warranties of merchantability or warranties of fitness for any particular use and all other obligations or liabilities in connection with the sale of this equipment.

| <u>Product Description</u>                    | <u>Warranty Coverage*</u> |
|---|---------------------------|
| • Ventilators .....                           | 1 year                    |
| • Heaters .....                               | 1 year                    |
| • Ventilator Hoses/Ducts .....                | 3 months                  |
| • Pel-Cans and Caddys.....                    | 1 year                    |
| • Hose Adapters .....                         | 1 year                    |
| • Manhole Shields & Manhole Guards .....      | 1 year                    |
| • Pel-Brite Work Lights .....                 | 6 months                  |
| • Planks and Plank Supports .....             | 6 months                  |
| • Duct Rodders and Accessories .....          | 6 months                  |
| • Submersible Pumps .....                     | 6 months                  |
| • Discharge and Suction Hoses for Pumps ..... | 3 months                  |
| • Wheel Chocks .....                          | 1 year                    |

\*From date of shipment to original buyer.

T.A. Pelsue Company, 2500 South Tejon Street, Englewood, Colorado 80110, 800-525-8460

## 2.0 - Introduction & Product Information

Congratulations on your choice of a **Pelsue Model #1325D Axial Ventilator** to compliment your confined space ventilation operation. This equipment has been designed and manufactured to exceed confined space requirements and regulations in order to meet the needs of the discriminating operator for efficiency and safety during confined space entry operations.

Safe, efficient and trouble-free operation and maintenance of the system requires that anyone who will be operating, maintaining, or inspecting the equipment, read, understand and follow all the operation, safety, maintenance, and inspection instructions contained within this manual. This manual covers the Pelsue Model #1325D Axial Ventilator. Use the Table of Contents as a guide to find specific information.

Keep this manual available for future reference if required, and as a tool in the training of new operators.

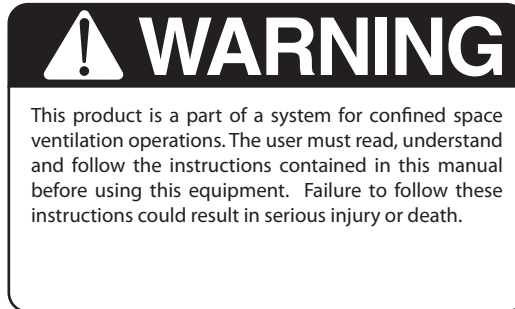

## 2.1 - Serial Number

### Product Serial Number

Always give your dealer the serial number of your Pelsue confined space ventilator product when ordering parts or requesting service or other information.

The identification & serial number decal is permanently embossed with a serial number. The identification & serial number decal is located on the main Ventilator housing as shown in *Fig. 2a*. The serial number decal will appear as shown to the right in *Fig. 2b*. A space has been provided below for the recording of the serial number for future reference.

MODEL: **#1325D** \_\_\_\_\_

Serial Number : \_\_\_\_\_

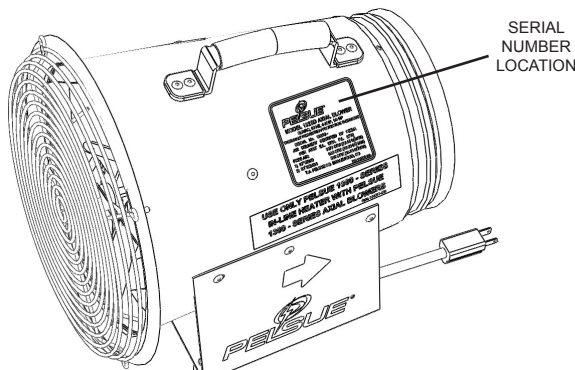

**Figure 2a:** Serial Number Location

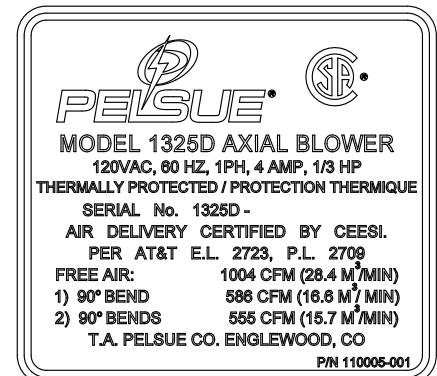

**Figure 2b:** #1325D Serial Number Plate

## 3.0 - Configuration & Assembly

Upon initial receipt of the #1325D Axial Ventilator, inspect the packaging for any evidence that the product may have been damaged in shipment. While unpacking the product, inspect all of the components for damage. If damage to any of the components is discovered, Alert the shipping carrier immediately of the damage to the shipment.

### 3.1 Parts Diagram & List

Refer to the following parts breakdown diagram (Figure #3.1a & #3.1b) and the accompanying parts list (Table #3.1a & #3.1b) for identification of parts in the event replacements become necessary. The parts list table displays applicable part numbers, descriptions, and quantity per assembly.

\*\*Refer to parts list above if replacement parts are required. Replacement parts can be ordered from the T.A. Pelsue Company at 800-525-8460.

| Item Number | Part Number | Description   | Quantity |
|-------------|-------------|---|----------|
| 3           | 110006-001  | WELDMENT - AXIAL HOUSING, 1300D / 1400D                               | 1        |
| 4           | 110021-001  | BASE - AXIAL BLOWER, PAINTED & SILKSCREENED                           | 1        |
| 5           | 100188-001  | FOOT - RUBBER, 3/4" OD, W/ WASHER                                     | 4        |
| 6           | 100405-004  | STRAIN RELIEF - WATERTIGHT, 1/2" HUB, 0.250"- 0.375" DIAM.            | 1        |
| 7           | 26E-005700  | CORDSET - W/MOLDED PLUG 16/3 SJTOW RATED                              | 1        |
| 8           | 119268-001  | FAN BLADE - 10" DIA., 3/8" SHAFT, 3450 RPM, ALUM, CW                  | 1        |
| 9           | 118809-001  | MOTOR MOUNT - AXIAL BLOWERS, HDPE / STEEL BLOWER HOUSINGS             | 1        |
| 10          | 110002-010  | ASSEMBLY - AXIAL MOTOR 120V/60Hz/1Ph, 1/3Hp. W/CAPACITOR, 3/8"SHAFT   | 1        |
| 11          | 126038-001  | END PLATE - AXIAL MOTOR, AFT (OUTLET) END, MOTOR SUPPORT              | 1        |
| 12          | 110000-001  | GRILLE - OUTLET, 1300D/1400D, AS POWDER COATED IN BLACK               | 1        |
| 13          | 126038-002  | VERTICAL RIB - AXIAL MOTOR, STEEL HOUSING, HANDLE LOCATION ATTACHMENT | 1        |
| 14          | 124331-001  | HANDLE - OVER-MOLDED VINYL HANDLE W/ RIVET-ON ENDS                    | 1        |
| 15          | 68N-004300  | WASHER - LOCK, INTERNAL TOOTH, #10, PLATED                            | 2        |
| 16          | 68N-035000  | SCREW - MACHINE, HEX HD, SLOT, 10-24 UNC X 3/8", PLATED               | 2        |
| 17          | 104977-001  | GRILLE - INTAKE, 1300D/1400D, AS POWDERCOATED BLK                     | 1        |
| 18          | 104151-001  | WASHER - RIVET BACK UP, 7/32" ID X 7/16" OD, SS                       | 6        |
| 19          | 100050-006  | WASHER - FLAT, #10, TYPE A, W, PLATED                                 | 6        |
| 20          | 110733-001  | LOCKNUT - HEX WITH NYLON INSERT, 10-32, BLACK                         | 6        |
| 21          | 118518-001  | RIVET - STAVEX, BLIND FLANGE DOME, BLACK, .188" DIA                   | 14       |
| 22          | 118519-001  | RIVET - STAVEX, BLIND FLANGE DOME, BLACK, .188" DIA                   | 8        |
| 23          | 26E-014100  | TERMINAL - BUTT SPLICE, 16GA - 14 GA, NYLON INSUL (NOT SHOWN)         | 3        |
| 24          | 26E-040210  | TERMINAL - QUICK DIS. FEMALE, 18-22, 1/4 TAB, NYL INS (NOT SHOWN)     | 2        |
| 25          | 105343-001  | TUBING - HEAT SHRINK, BLK, 3/8" (NOT SHOWN)                           | 6        |
| 26          | 110005-001  | DECAL - ID & SERIAL PLATE, 1325D AXIAL BLOWER                         | 1        |
| 27          | 104011-001  | DECAL - "USE ONLY PELSUE 1600-SERIES IN-LINE..." 1300 SERIES          | 1        |

**Table 3.1a: #1325D**  
Parts List

| Item Number | Part Number | Description  | Quantity |
|-------------|-------------|--|----------|
| 3           | 110002-001  | MOTOR - ELECTRIC, AXIAL, 3/8" SHAFT, 120VAC                        | 1        |
| 4           | 110007-001  | CAPACITOR - 7.5 MFD, 370 VAC, 60 HZ                                | 1        |
| 5           | 110288-001  | COVER - RUBBER, CAPACITOR CONNECTION                               | 1        |
| 6           | 119023-001  | GASKET, FOAM STRIP, 3/8" X 1" X 11" LG. NEOPRENE W/PSA CLOSED CELL | 0.091    |
| 7           | 114628-001  | CAPACITOR BRACKET - 7.5 MFD, 370 VAC, 60HZ                         | 1        |

**Table 3.1b: #110002-010**  
Parts List



### 3.1 Parts Diagram & List (continued)

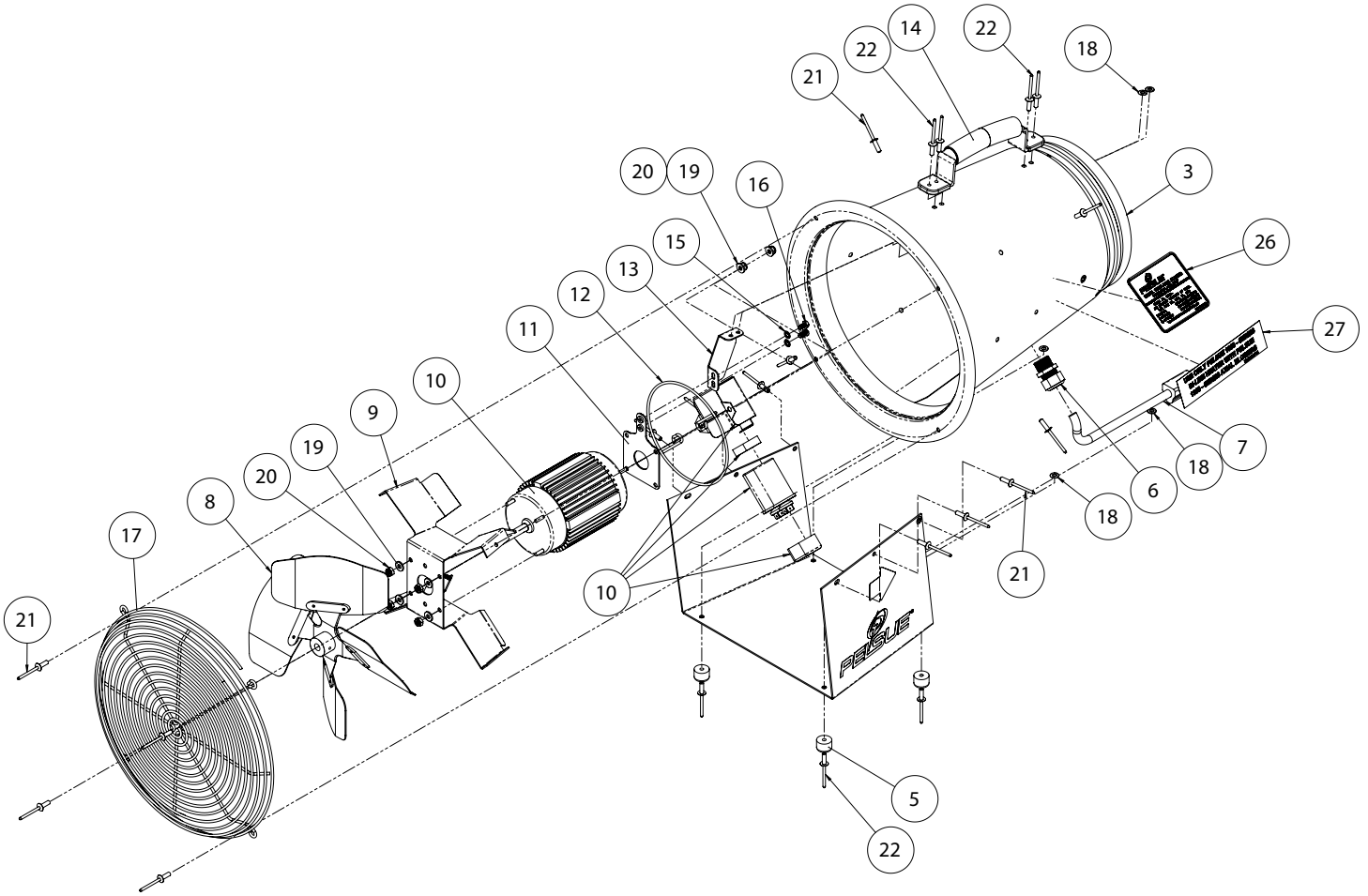

**Figure 3.1a: #1325D**  
Parts Diagram

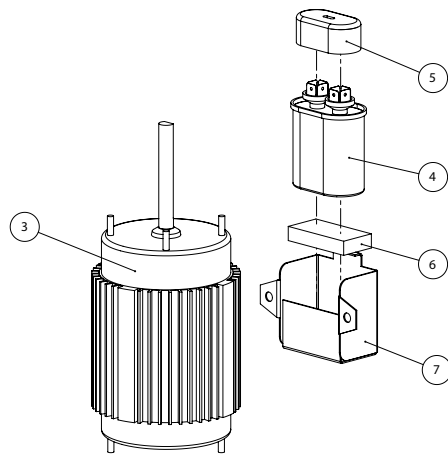

**Figure 3.1b: #110002-010**  
Parts Diagram

## 3.2 Wiring Diagram

Shown below in Figure 3.2a, is a wiring diagram of the motor and the cordset.

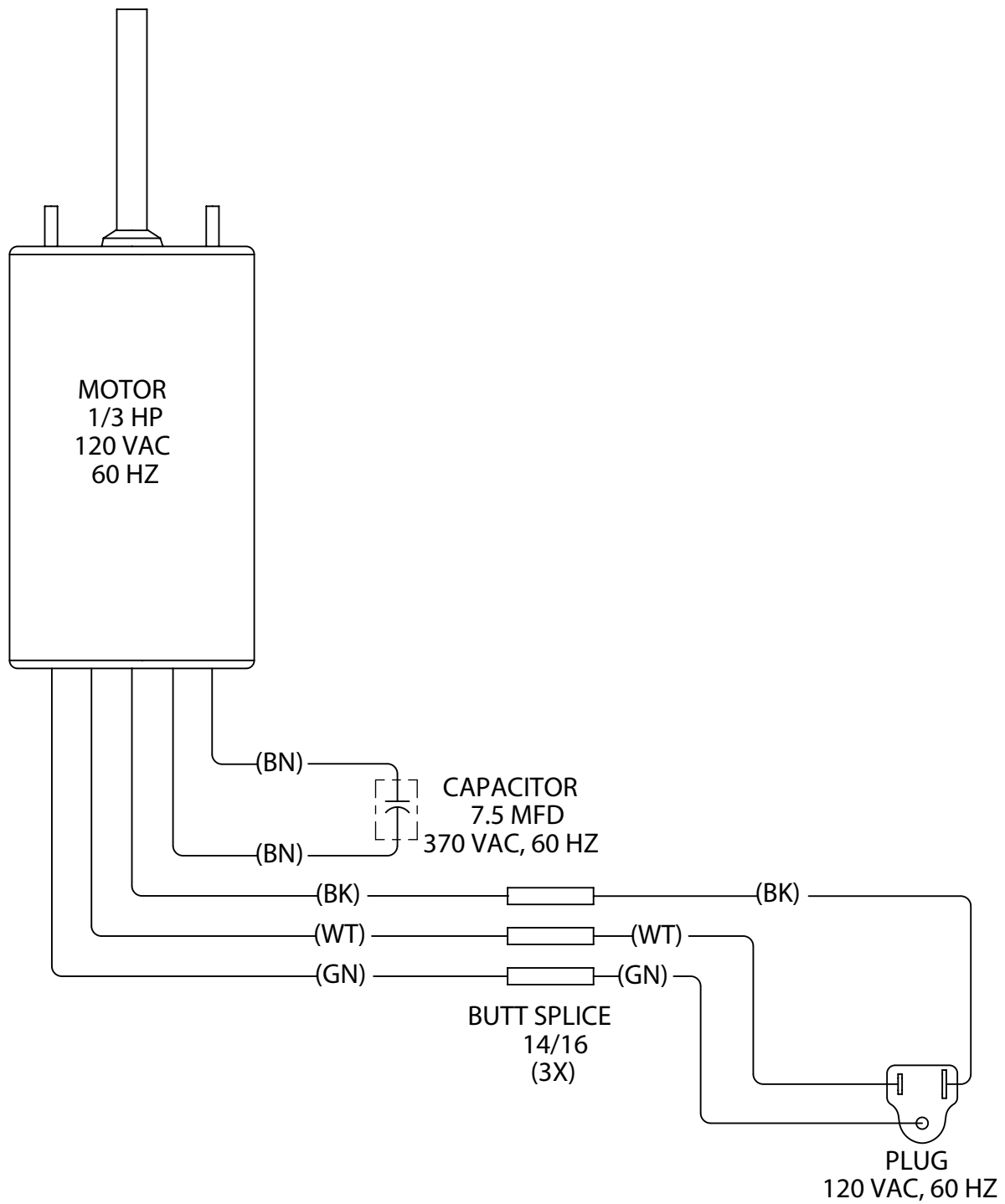

**Figure 3.2a:** #1325D  
Wiring Diagram

## 4.0 - Safety

---

The following section will address the safety precautions which must be adhered to when working with Pelsue confined Space Ventilation equipment such as the #1325D Axial Ventilator. Any user must familiarize themselves with the information in this section before utilizing the equipment.

### **SIGNAL WORDS:**

Note the use of the signal words **DANGER**, **WARNING** and **CAUTION** with the safety messages. The appropriate signal word for each message has been selected using the following guidelines:

- DANGER-** Indicates an imminently hazardous situation that, if not avoided, will result in death or serious injury. This signal word is to be limited to the most extreme situations or for hidden or unseen hazards.
- WARNING-** Indicates a potentially hazardous situation that, if not avoided, could result in death or serious injury and includes obvious and hidden hazards. It may also be used to alert against unsafe practices.
- CAUTION-** Indicates a potentially hazardous situation that, if not avoided, may result in minor or moderate injury. It may also be used to alert against unsafe practices.

You are responsible for the safe operation of your Pelsue #1325D Axial Ventilator. You must ensure that anyone who will operate or work around the equipment be familiar with confined space ventilation procedures. This manual will take you step-by-step through the workings and capabilities of the #1325D Axial Ventilator and alert you to all good safety and operating practices while using the system.

Remember, you are the key to safety. Good safety practices not only protect you but also the people around you. Make these practices a working part of your safety program. Be certain that everyone operating in or around a confined space is familiar with the procedures recommended and follows safety precautions. Remember, most accidents can be prevented. Do not risk injury or death by ignoring good safety practices.

- The most important safety device on this equipment is a safe operator. It is the operator's responsibility to read and understand all safety and operating instructions in the manual and to follow these. Most accidents can be avoided.
- A person must understand the operation of this equipment and be trained in its usage before operating the equipment. An untrained operator exposes himself and others to possible serious injury or death.
- Do not modify the equipment in any way. Unauthorized modification may impair the function and/or safety and could affect the life of the equipment.
- Think SAFETY! Work SAFELY!

## 4.1 - Safety Alert Symbol

---

### **SAFETY ALERT SYMBOL**

This Safety Alert symbol means **ATTENTION! BECOME ALERT! YOUR SAFETY IS INVOLVED!**

The Safety Alert symbol identifies important safety messages on your Pelsue Confined Space Product and in the manual. When you see this symbol, be alert to the possibility of personal injury or death. Follow the instruction in the safety message.

Why is this symbol important to you?

- 3 BIG Reasons:**
- Accidents Disable and Kill.**
  - Accidents Cost You Money.**
  - Accidents Can Be Avoided.**



## 4.2 - General Safety Information

---

### **Safety Precautions:**

It is necessary to follow these safety precautions, each time, prior to using the product.

The Safety Precautions is not limited to, but must include the following items;

1. Do not use the Ventilator for anything other than its intended use.
2. Do not wear loose clothing that can become entangled in operating machinery. Do not operate the Ventilator without inlet or outlet screen guards in place.
3. Do not place fingers or any other object through inlet or outlet screens.
4. Always operate the Ventilator from a properly grounded ground fault circuit interrupter-equipped receptacle.
5. Never handle energized power cords with wet hands.
6. Never let extension cords or plug connection lay in water. Locate the Ventilator so that it cannot fall into water inadvertently.
7. Never use cords with frayed , cut, or brittle insulation. Check the cord for sound connections to the ground fault interrupter receptacle.
8. Never use this Ventilator in an explosive environment.
9. Ensure that toxic fumes are not blown into a confined space.
10. Unattended use of equipment is not recommended.



**! CAUTION !** - Be sure the Ventilator is disconnected from the power source before doing any maintenance or repair work on the Ventilator.

**! CAUTION !** - Check all power cords for cuts, frayed ends, or brittle insulation. See parts list for replacement cord part number.

**! CAUTION !** - The user must ensure that the Ventilator is located where it cannot fall into water inadvertently and the extension cords or plug connections do not lay in water.

### **For Parts & service;**

#### **T.A. Pelsue Service Department**

2500 South Tejon Street  
Englewood, Colorado 80110  
Phone: 800-525-8460 or 303-936-7432  
Fax: 303-934-5581  
[www.pelsue.com](http://www.pelsue.com)

# 5.0 - Product Operation

The following section will address the capabilities and the general operation of the Pelsue #1325D Axial Ventilator. The instructions contained within this section should be adhered to each and every time the product is used. Any person tasked with installing or operating the piece of equipment should be familiar with these procedures.

## 5.1 - Product Description & Capabilities

The Pelsue #1325D Axial Ventilator is built with a cold rolled steel housing for exceptional strength and durability. The Pelsue #1325D Axial Ventilator is specifically designed for confined space applications. All specifications, instructions, and procedures provided within this manual or upon Pelsue Specification Documents are based upon and only valid for usage with Pelsue accessories. The T.A. Pelsue Company can not verify equipment safety and/or compliance when utilized with anything other than Pelsue approved confined space accessories.

### Axial Ventilator - #1325D

#### General Specifications

- Weight - 19.5 LBS.
- Height - 14-1/2"
- Width - 13"
- Length - 14-1/2"

#### Model Specifications & Performance

##### #1325D

- Voltage 120VAC, 60Hz
- Amperage 4
- H.P. 1/3 (.248kW)
- Free Air 1004 CFM (28.4 m3/min)
- One 90° Bend 568 CFM (16.6 m3/min)
- Two 90° Bends 555 CFM (15.7 m3/min)

#### Features:

- Low Maintenance
- Specifically designed to provide a completely portable source of fresh air

#### Materials & Construction

- Main Structure: - Cold Rolled Steel
- Hardware - Plated Steel

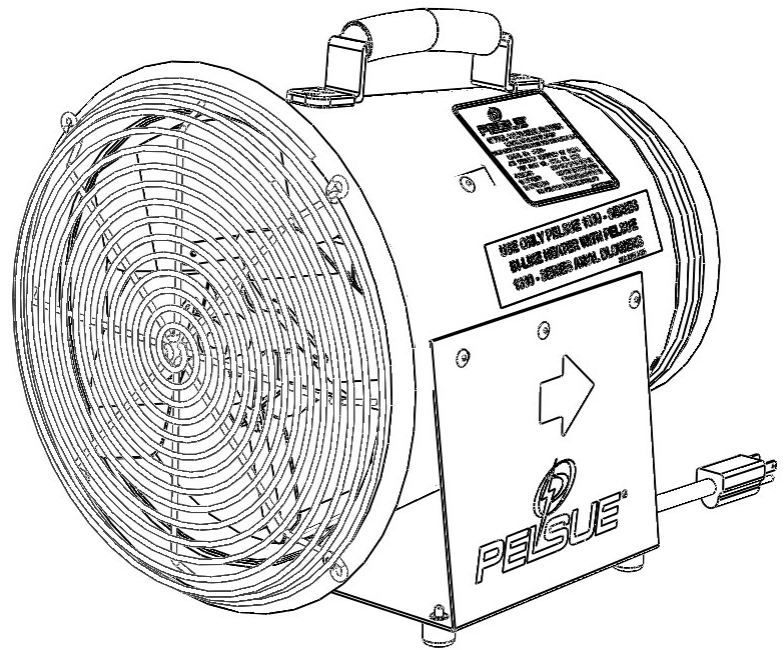

**Figure #5.1a:** #1325D Axial Ventilator

#### Additional Requirements & Notes

- The #1325D Axial Ventilators are single-speed Ventilators.

## 5.2 - Start-Up & Operating Procedures

Prior to Operation, the #1325D Axial Ventilator should be configured and prepared according to the following guidelines.

### 1. Pre-Operation Inspection:

It is necessary to perform a visual inspection, each time, prior to using the product. If deficiencies are found, remove the product from service and contact the T.A. Pelsue regarding repair. The following checklist coupled with *Figure #5.2a* should be used as a guide to determine whether the equipment is in good operating condition prior to usage. Equipment that is not in good condition can endanger the safety of the entrant and attendant during use.

The Pre-Operation Visual Inspection is not limited to, but must include the following items;

- a. Check the Ventilator inlet and outlet guard screens for obstructions.
- b. Remove any objects around the immediate area that could be sucked into the Ventilator.
- c. The cordset is properly attached to the Ventilator.
- d. The rubber feet are attached.

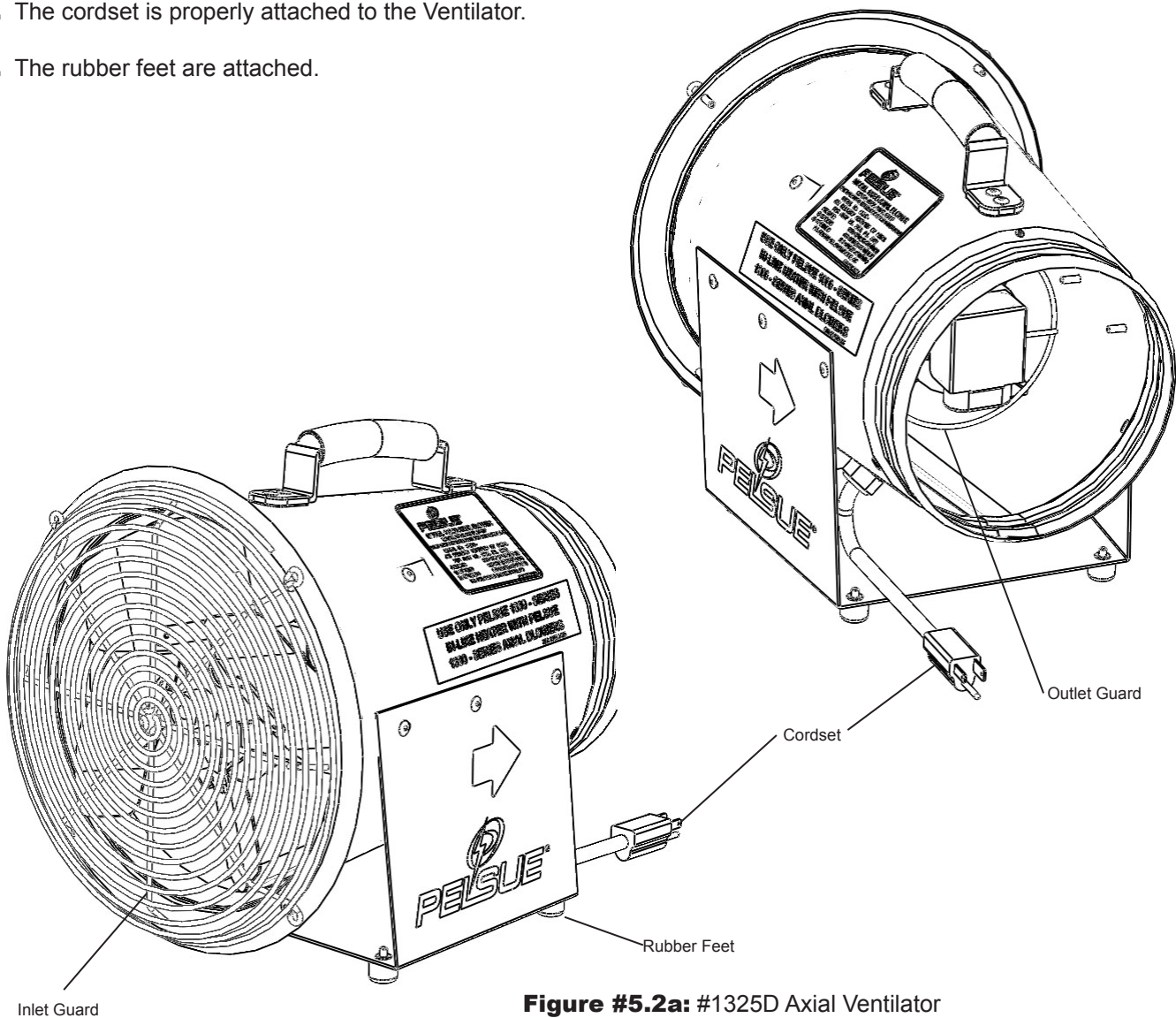

**Figure #5.2a:** #1325D Axial Ventilator  
Pre-Operation Inspection Points

## 5.2 - Start-Up & Operating Procedures (continued)

### 2. Setup of 1325D Axial Ventilator:

Choose a location where installation will provide suitable proximity to the work area yet minimize obstructions during use and in the event a rescue is necessary. Once a location is chosen;

- Ventilator should be placed 1.5 meters upwind where possible, from the confined space, and have its inlet pointed into the wind. This will reduce the chance of contamination being blown into the confined space. (Refer to Fig. #5.2b)
- Plug the Ventilator power cord to a properly grounded receptacle.
- Extend and place the Ventilator hose as required.
- When Ventilator operation is no longer required, unplug the power cord. Coil and store the power cord in the space between the housing and base or in the outlet port of the Ventilator.

### Important Notes:

- During confined space entry operations, it should not be assumed that the ventilator will maintain the air inside the confined space at a safe condition. When the ventilator is in use, the air inside the confined space should be monitored continuously for the presence of poisonous gases and/or toxic fumes.
- Ensure that the Ventilator provides positive airflow the entire time during usage. The axial Ventilator can be used with an accessory Pelsue Air Flow Alarm (FLO-CHEK) in order to alert the entrants that positive ventilation is lost.

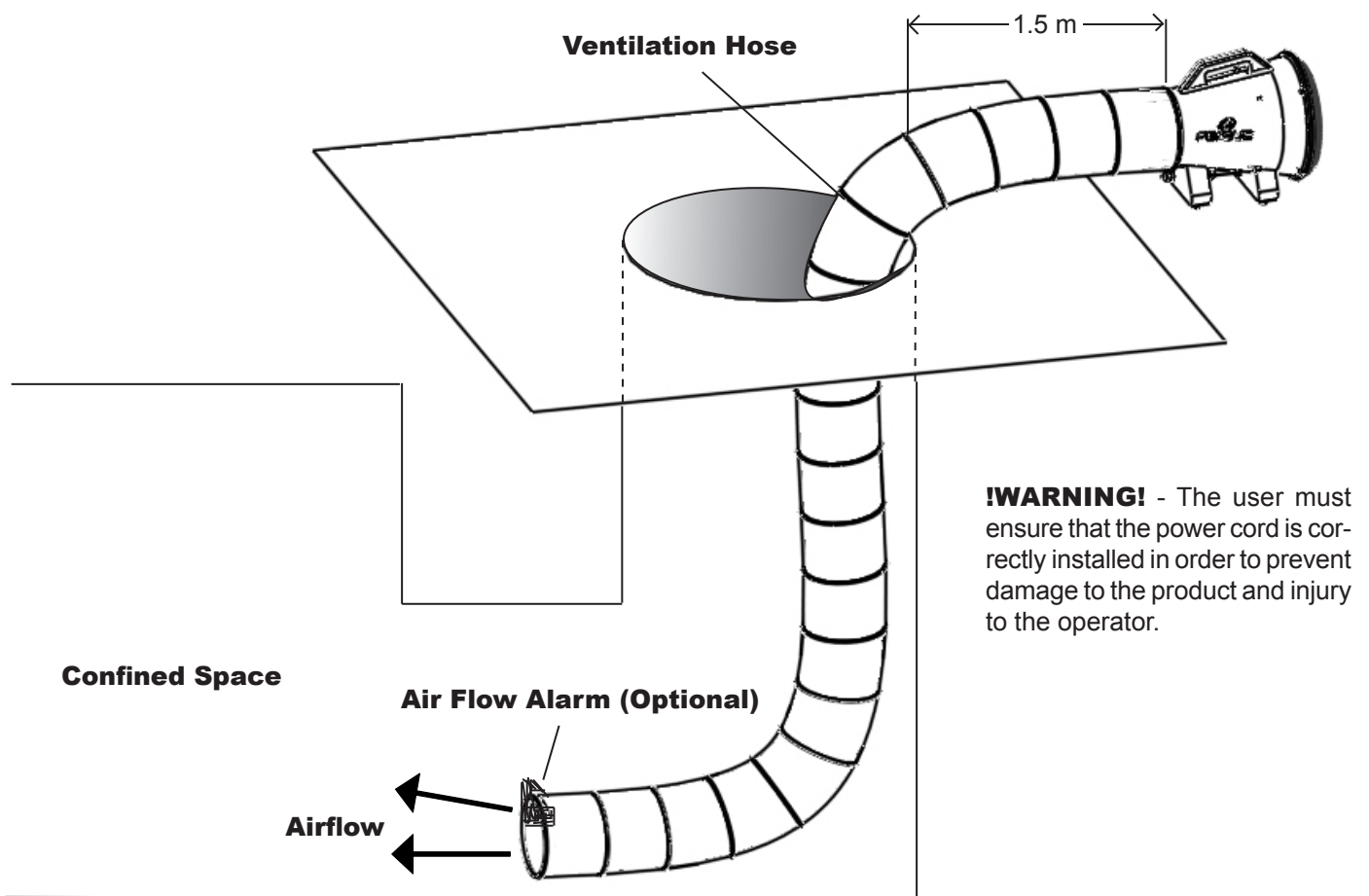

**Figure #5.2b:** Axial Ventilator Setup in Confined Space



**T.A. Pelsue Company**

2500 South Tejon Street, Englewood, Colorado, USA 80110  
Toll free 800-525-8460 or 303-936-7432 Fax. 303-934-5581  
Internet: [www.pelsue.com](http://www.pelsue.com) Email: [sales@pelsue.com](mailto:sales@pelsue.com)