



# Product Specifications

## Model #BC-08A Adjustable Angle Clamp (For use with Pelsue FT-C70 Fall Arrest Post)

The Pelsue Adjustable Angle Clamp is constructed from carbon steel and has steel hardware. The Adjustable Angle Clamp is specifically designed to provide a portable mounting base for a fall arrest post on structural angle sections. The clamp can be installed in two different configurations depending on the orientation of the angle beam. The #BC-08A is designed to fit on a number of different size angles that can range from 3.5" to 8" and a flange thickness ranging from 3/16" to 3/4". All specifications provided are based upon and only valid for usage with Pelsue Fall Arrest Post Model #FT-C70. The T.A. Pelsue Company can not verify equipment safety and/or compliance when utilized with any other system.

### General Specifications:

Product is designed and tested to be used in a General Application:

1. As a portable Fall Arrest Post mounting base

**Man Rated Load Capacity Using Fall Arrest Post.....**Rating is determined by fall arrest post.

**Warning!** A 900 LB. maximum arrest force (MAF) fall arrest device must be used when system is employed as part of a complete fall arrest system. Maximum weight of person upon anchorage is 350 LBS. (159 KG.) inclusive of all tools and equipment.

### Materials & Construction:

**General Construction.....**Welded Carbon Steel, Zinc Plated

- Hardware .....Grade 8 Steel Zinc Plated Steel

### Weight:

**Weight.....**35 lbs. (15.9 kg)

### Features:

- For portable usage on angular structural sections
- Can be installed in two configurations (normal & inverted) depending on beam orientation
- Provides a mounting base for a Pelsue Fall Arrest Post Model #FT-C70
- Two adjustment bolts allow for various flange thicknesses

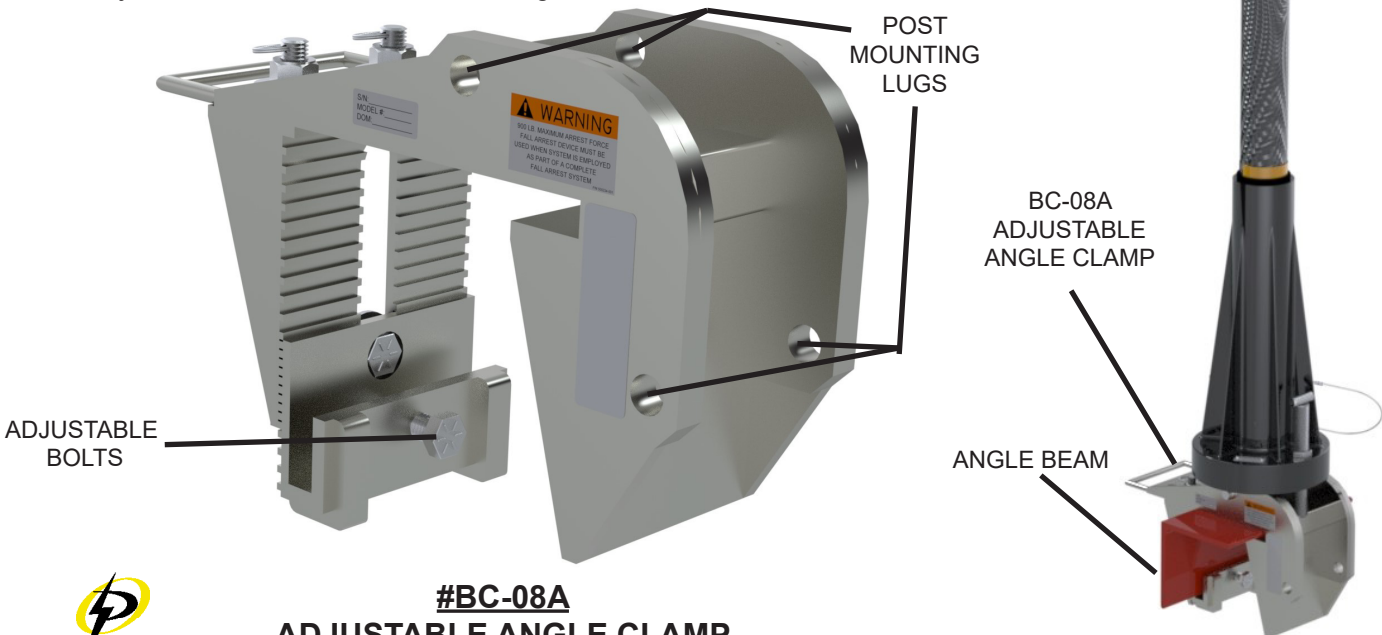

**#BC-08A  
ADJUSTABLE ANGLE CLAMP**

**ADJUSTABLE ANGLE CLAMP SHOWN  
ON A TYPICAL STRUCTURAL ANGLE SECTION  
WITH A MODEL #FT-C70  
FALL ARREST POST INSTALLED**



2500 S. Tejon St.  
Englewood, CO 80110  
Ph: 1-800-525-8460, (303) 936-7432  
Fax: (303)934-5581  
Web: www.pelsue.com E-mail: sales@pelsue.com



# Product Specifications

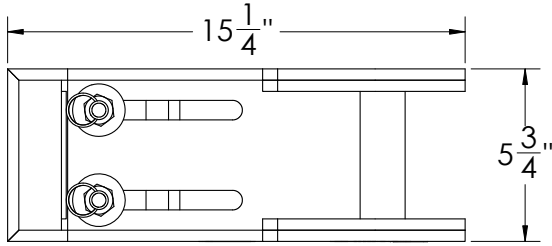

**TOP VIEW**

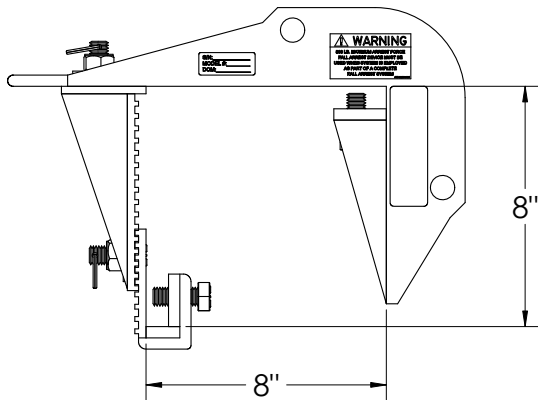

**SIDE VIEW  
MAXIMUM ANGLE BEAM**

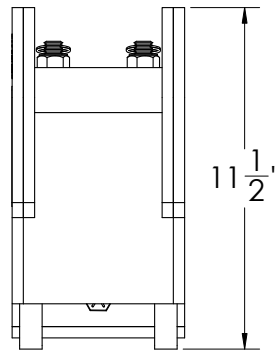

**FRONT VIEW  
MAXIMUM ANGLE BEAM**

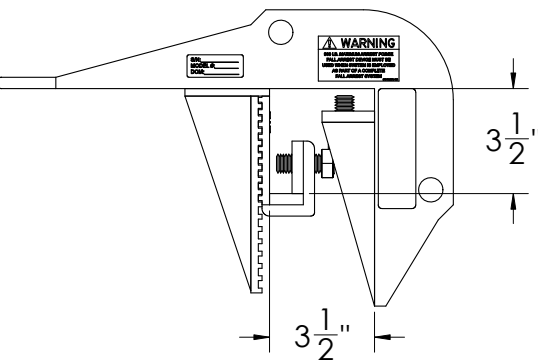

**SIDE VIEW  
MINIMUM ANGLE BEAM**

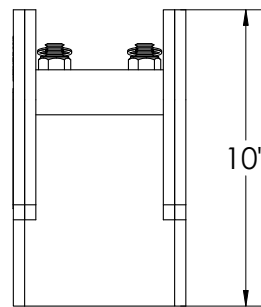

**FRONT VIEW  
MINIMUM ANGLE BEAM**

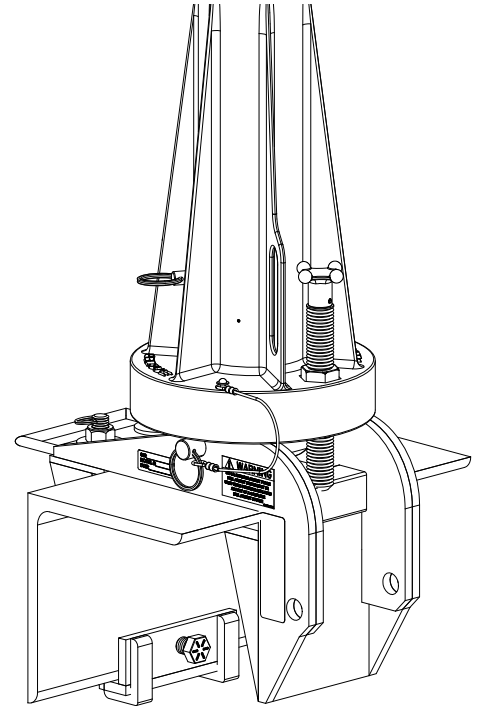

**TOP MOUNT**

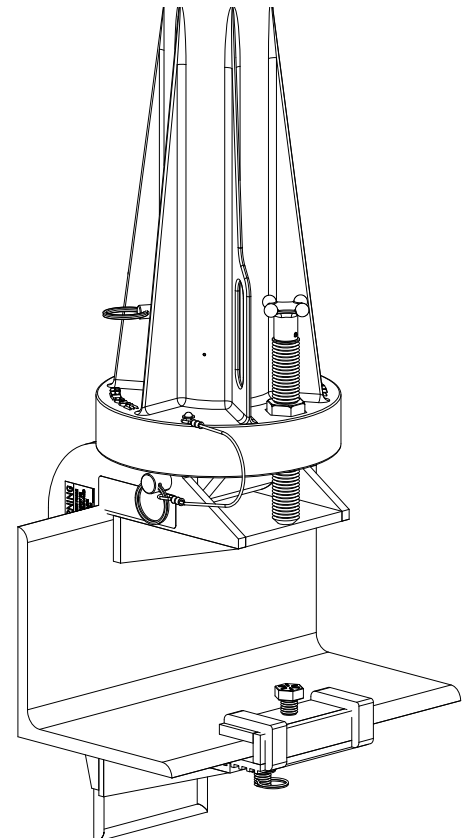

**EDGE MOUNT**



2500 S. Tejon St.  
 Englewood, CO 80110  
 Ph: 1-800-525-8460, (303) 936-7432  
 Fax: (303)934-5581  
 Web: [www.pelsue.com](http://www.pelsue.com) E-mail: [sales@pelsue.com](mailto:sales@pelsue.com)