

Part #950130-001

Product Manual:

Model #6759
Work Umbrella



PELSUE[®]
ISO 9001 Certified

T.A. Pelsue Company
2500 South Tejon Street
Englewood, Colorado, USA 80110
Tel. 800-525-8460 or 303-936-7432
Fax. 303-934-5581
Internet: www.pelsue.com
Email: sales@pelsue.com

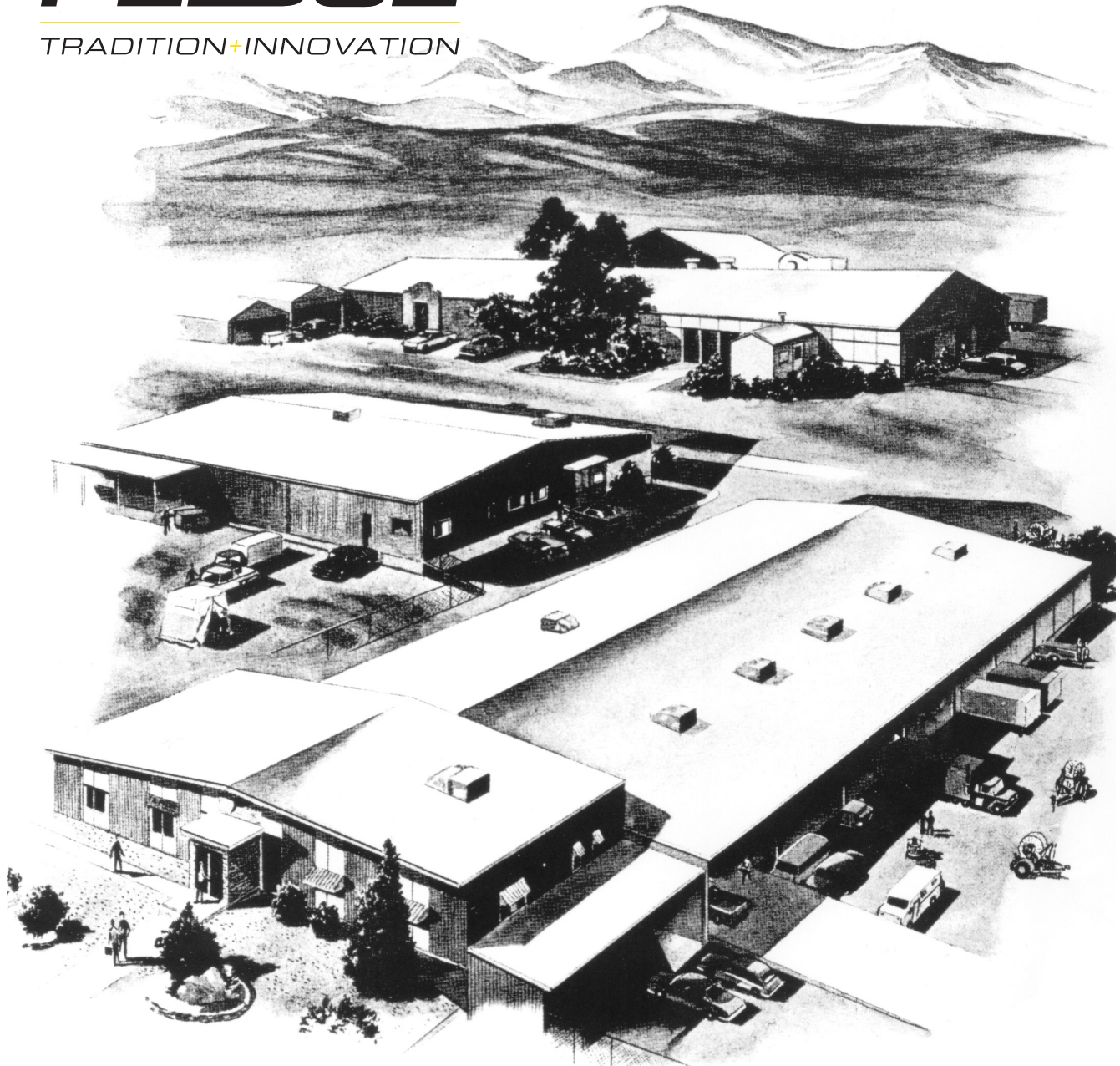

Since our inception in 1963 – the T.A. Pelsue Company has designed and manufactured high quality equipment to improve the personnel efficiency and working conditions in various underground, confined, and outdoor areas.

Founded by T. Allen Pelsue, the company has established a continuing reputation for excellence in the production of fine products for a broad spectrum of industry throughout the world.

Now, in our second generation of family direction, continued commitment to innovation and quality makes Pelsue a leading source of equipment for many types of confined spaces. We specialize in safety, retrieval, fall arrest, ventilation, cable placing, splicing, and maintenance nationally and abroad. With more than 70,000 square feet of facilities available, Pelsue continues the dedication that has made us pre-eminent in this field.

Table of Contents

Section	Description	Page #
1.0	General Information	5
1.1	Quality Policy	
1.2	Pelsue Product Warranty	
2.0	Introduction & Product Information	7
2.1	Serial Number	
3.0	Configuration & Assembly	8
3.1	Parts Diagram & List	
4.0	Safety	10
4.1	Safety Alert Symbol	
4.2	General Safety Information	
5.0	Product Operation	12
5.1	Product Description & Capabilities	
5.2	Set-Up, Operating, & Take-Down Procedures	

T.A. Pelsue Company

Quality Policy

OUR GOAL IS THE PURSUIT OF NEVER-ENDING IMPROVEMENT IN PRODUCT QUALITY AND BUSINESS SYSTEMS.

METHODS TO BE EMPLOYED IN ATTAINING THIS GOAL WILL INCLUDE NEW PRODUCT QUALITY PLANNING, EMPLOYEE TRAINING, AND UTILIZATION OF EMPLOYEE INVOLVEMENT GROUPS TO SOLVE PROBLEMS.

IN AN INCREASINGLY COMPETITIVE MARKETPLACE, ENSURING CUSTOMER SATISFACTION IS ONE OF THE DIFFERENTIATORS THAT SETS YOU APART FROM THE PACK AND YIELDS A COMPETITIVE ADVANTAGE.

THEREFORE, WE WILL SUPPORT TOTAL CUSTOMER SATISFACTION BY IMPLEMENTING THE **ISO 9001 QUALITY SYSTEM** AND PROVIDING THE NECESSARY ATMOSPHERE AND TRAINING TO NURTURE THIS CONCEPT THROUGHOUT OUR ORGANIZATION.

WE WILL MAKE EVERY BUSINESS DECISION AS THOUGH THE QUALITY OF THE PART OR SERVICE PROVIDED WAS DESTINED FOR OUR OWN OR OUR FAMILY'S USE. WE WILL ALWAYS THINK **QUALITY FIRST**.

EVERY T.A. PELSUE COMPANY EMPLOYEE IS EXPECTED TO COMMIT TO THIS PHILOSOPHY IN THE PERFORMANCE OF HIS OR HER DAILY TASKS.

QUALITY FIRST!

T.A. PELSUE COMPANY SENIOR MANAGEMENT TEAM

1.2 - Pelsue Product Warranty

PELSUE SEWN GOODS PRODUCT WARRANTY

- Pelsue sewn goods are designed and engineered to perform as stated in published specifications. Quality materials and workmanship are used in the manufacture of this product. With regular maintenance and proper care, Pelsue equipment provides many trouble free hours of operation.
- The T.A. Pelsue Company warrants to the buyer that material furnished will conform to specifications and will be free from defects in material and workmanship from the date of shipment to the original buyer, for the period listed by product description at the bottom of this warranty statement.
- In the event of failure of any components of a Pelsue product within the warranty period, service must be pre-approved by the T.A. Pelsue Company and service must be performed by the T.A. Pelsue Company Parts and Service Department in Englewood Colorado, or at the option of T.A. Pelsue Company, service may be performed at any designated service center, which may include any authorized service center for the component manufacture.
- Damage or failure due to misuse, mishandling, unauthorized modifications, wear and tear or extreme weather, will not be covered by this warranty. Unless otherwise agreed, the T.A. Pelsue Company shall repair or replace the defective product or component within (30) calendar days of notice of failure. T.A. Pelsue Company's obligation hereunder, shall be limited to the repair or replacement of the product or component as set forth above, and shall not include any liability whatsoever for damages caused by such failure, including but not limited to consequential or incidental damages flowing from use or lack of use of product.
- Components found defective shall be returned to T.A. Pelsue Company for repair or replacement, with the risk of loss borne by buyer and freight paid by buyer. The T.A. Pelsue Company shall repair or replace the defective components and ship within (30) days of receipt of defective component. The repaired or replaced component will be returned to customer, freight prepaid by T.A. Pelsue Company. If material returned to T.A. Pelsue Company for repair, as provided for in this section, is determined to be beyond repair, the T.A. Pelsue Company shall notify the sender and, unless otherwise agreed, will ship a replacement unit within (30) days of such notification, subject to availability. T.A. Pelsue Company's obligation hereunder, shall be limited to the repair or replacement of the product as set forth above and shall not include any liability whatever for damages caused by such defect, including but not limited to consequential or incidental damages flowing from loss of use.
- Any replacement, repair, modification, installation or other service performed by the T.A. Pelsue Company shall be warranted by the remainder of the unexpired period of the warranty, or for a period of (30) calendar days, whichever is longer.
- All materials or parts returned for credit or warranty shall be returned only with prior approval, and will be subject to factory inspection before credit is allowed. Products or parts claimed defective will be replaced upon request and will be invoiced as purchased, subject to credit when the products or parts claimed to be defective have been received and examined by the factory.
- Pelsue tents are constructed of flame retardant fabric meeting CPAI-84 or NFPA 701 or both. While flame retardant, these fabrics will burn if exposed to any open flame. Use caution around open flames or hot surfaces.
- Pelsue tents are seam sealed on all roof seams at the factory. Occasional resealing will be necessary depending upon use and weather conditions. Seam sealer for this purpose is included with your stake kit.
- This warranty is expressly in lieu of all other warranties expressed or implied, including any warranties of merchantability or warranties of fitness for any particular use and all other obligations or liabilities in connection with the sale of this equipment.

DURATION OF WARRANTY

- Tents and Sewn Products 1 Year

2.0 - Introduction & Product Information

Congratulations on your choice of a **Pelsue Model #6759 Work Umbrella** to facilitate your remote location shelter requirements. This equipment has been designed and manufactured to meet the needs of the discriminating operator for efficiency and safety during operations which require protection from the weather. The Umbrella is designed as a shelter for technicians as well as equipment in outdoor or exposed locations.

Safe, efficient and trouble-free operation and maintenance of the system requires that anyone who will be operating, maintaining, or inspecting the equipment, read, understand and follow all the operation, safety, maintenance, and inspection instructions contained within this manual. This manual covers the Pelsue Model #6759 Work Umbrella. Use the Table of Contents as a guide to find specific information.

Keep this manual available for future reference if required, and as a tool in the training of new operators.

2.1 - Serial Number

Product Serial Number

Always give your dealer the serial number of your Pelsue Portable Shelter product when ordering parts or requesting service or other information.

The identifying decal is permanently embossed with a serial number. The ID decal is located in the corner of the inner side of the roof, as shown in *Fig. 2a*. The entire support structure has been omitted from *Fig. 2a* for clarity. The decal will appear as shown to the right in *Fig. 2b*. A space has been provided below for the recording of the serial number for future reference.

MODEL: #6759 _____

Serial Number : _____



Manufactured by:

T.A. Pelsue Company
2500 South Tejon Street
Englewood, Colorado 80110
www.pelsue.com
email: sales@pelsue.com
Toll Free: 1-800-525-8460
Main: 303-936-7432



MODEL # _____ **6759**
SERIAL # _____ **#####**

WARNING!! - Keep all flame and heat sources away from this tent fabric!

This tent is made with flame resistant fabric which meets CPAI-84 specifications. It is not fireproof. The fabric will burn if left in continuous contact with any flame source.

The application of any foreign substance to this tent fabric may render the flame resistant properties ineffective.

This product is covered by one or more of the following U.S. Patents. Other U.S. and Foreign Patents pending.
4,941,499 / 3,941,140 / 4,026,312 / 4,077,417 / 4,450,851 / 4,637,748 / 4,819,680

117198-001

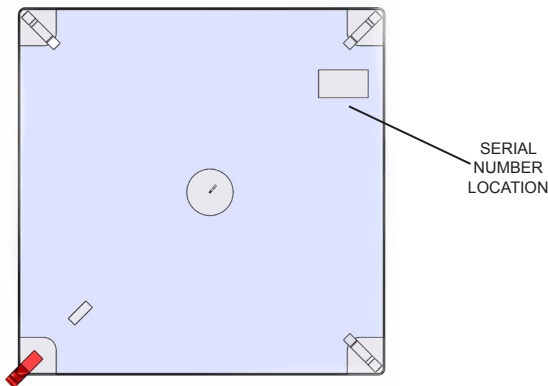

Figure 2b: #6759
Serial Number Decal

Figure 2a: Serial Number
Location - Support Structure Omitted for Clarity

3.0 - Configuration & Assembly

Upon initial receipt of the Model #6759 Umbrella, inspect the packaging for any evidence that the product may have been damaged in shipment. While unpacking the product, inspect all of the components for damage. If damage to any of the components is discovered, Alert the shipping carrier immediately of the damage to the shipment.

3.1 Parts Diagram & List

Refer to the following parts breakdown diagram (Figure #3.1a) and the accompanying parts list (Table #3.1a) for identification of parts in the event replacements become necessary. The parts list table displays applicable part numbers, descriptions, and quantity per assembly.

* Replacement parts can be ordered from the T.A. Pelsue Company at 800-525-8460.

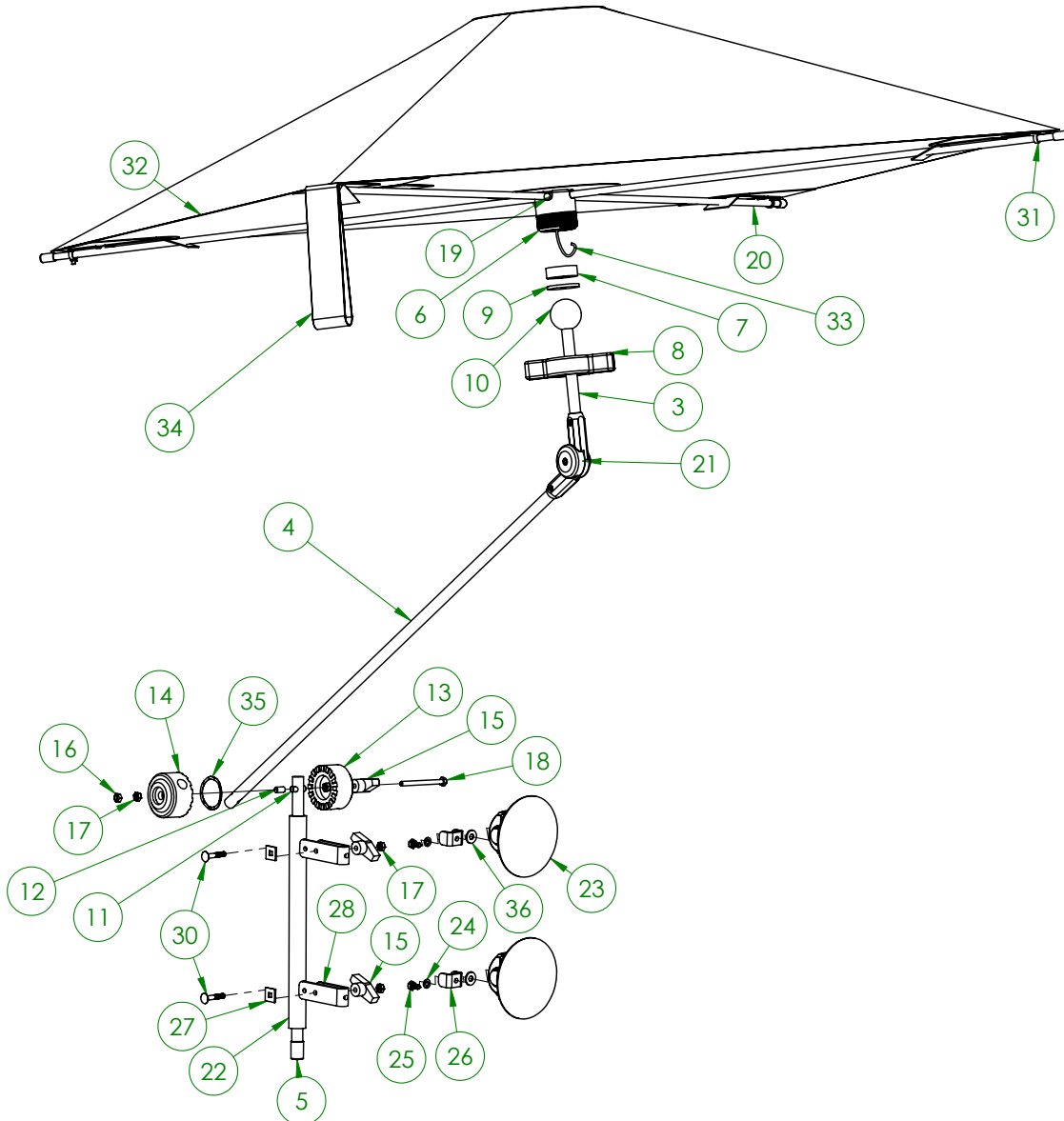

Figure 3.1a: #6759
Parts Diagram

3.1 Parts Diagram & List (continued)

ITEM NUMBER	PRODUCT NUMBER	DESCRIPTION	QUANTITY
3	114714-004	ROD - FIBERGLASS, 5/8" DIA. X 7.50" LG	1
4	114714-003	ROD - FIBERGLASS, 5/8" DIA. X 36.00" LG	1
5	114714-002	ROD - FIBERGLASS, 5/8" DIA. X 16.00" LG, W/ VINYL TIP	1
6	126544-010	HUB - BASE CUP	1
7	126545-001	HUB PLATE - THREADED BALL LOCK	1
8	126546-001	COLLAR - THREADED BALL LOCK	1
9	126547-002	DISC - RUBBER, 1.8" DIA. X 0.16" THICK, 0.25" HOLE	1
10	126547-U01	BALL - STYRENE, 1-3/4" DIAMETER, AS MODIFIED	1
11	126570-S01	SLEEVE - TUBING, STAINLESS, 0.9 L X .3125 OD X 22GA W	1
12	126570-S02	SLEEVE - TUBING, STAINLESS, 0.54L X .3125 OD X 22GA W	1
13	126570-001	HINGE - TOOTHED, BLACK ACETAL, FEMALE SIDE	1
14	126571-001	HINGE - TOOTHED, BLACK ACETAL, MALE SIDE	1
15	126704-001	KNOB - SNAPLOCK, BL PLASTIC, 2" W X 1" D, HEX RECESS	3
16	107941-001	NUT - STOVER, 1/4-20 UNC, GRADE 5	1
17	100048-010	NUT - HEX, 1/4-20 UNC, PLATED	4
18	126729-001	SCREW - TAP, HEX HD, 1/4-20 X 3" L, ALLTHREAD S. STEEL	1
19	100216-002	ROD END - TENT HUB, RES-6, .375 ID, ZINC	4
20	104029-001	ROD - F GLASS, .375 DIA X 41.5, CHAMFERED, ONE VINYL TIP	4
21	126552-001	HINGE - LOCKING, PLASTIC, 220° ROTATION, 5/8" HOLES	1
22	106503-000	HOSE - RUBBER, 5/8" ID, HEATER HOSE, BLACK	1
23	118864-001	VACUUM MOUNT - SUCTION CUP, 4.5" DIA., 1/4-20 INSERT	2
24	100121-009	WASHER - LOCK, 1/4 IN, HELICAL SPG, PLATED	2
25	100604-005	SCREW - HEX HD, 1/4-20 UNC X 1/2", PLATED, GRADE 5	2
26	126715-002	BRACKET - U-SHAPED, FOR RUBBER CUP MOUNT	2
27	126687-001	WASHER - SQAURE, 1/4" ID, 3/4" OD	2
28	126553-R01	STRAP - RUBBER, CUP CLAMP, 6.29" L X 1.00" W X 0.175" T	2
29	126553-G01	GROMMET, 9/32" ID X 0.300 BARREL LENGTH, STAINLESS	2
30	126729-002	BOLT - CARRIAGE, 1/4-20 UNC X 1-1/2", STAINLESS STEEL	2
31	121900-008	CABLE TIE - 8" BLACK, ZIP TIE, WIRE, 450-T50R0	3
32	126542-001	ROOF - SEWN ASSEMBLY, SHADE MATERIAL, 59" X 59"	1
33	126703-S01	ROPE - 4 DIAMOND BRAID, TIE-OFF ROOF TO HUB	1
34	126555-001	HANDLE - WEBBING, RED, 2" WIDE, WITH ROD POCKET	1
35	126570-R02	SPRING - SINGLE TURN, 4 WAVE, STAINLESS, GAP, 1.875 OD	1
36	100050-009	WASHER - FLAT, 1/4 IN, TYPE A, W, PLATED	1

Table 3.1a: #6759
Parts List

4.0 - Safety

The following section will address the safety precautions which must be adhered to when working with Pelsue Portable Shelter equipment such as the #6759 Work Umbrella. Any user must familiarize themselves with the information in this section before utilizing the equipment.

SIGNAL WORDS:

Note the use of the signal words **DANGER**, **WARNING** and **CAUTION** with the safety messages. The appropriate signal word for each message has been selected using the following guidelines:

- DANGER-** Indicates an imminently hazardous situation that, if not avoided, will result in death or serious injury. This signal word is to be limited to the most extreme situations or for hidden or unseen hazards.
- WARNING-** Indicates a potentially hazardous situation that, if not avoided, could result in death or serious injury and includes obvious and hidden hazards. It may also be used to alert against unsafe practices.
- CAUTION-** Indicates a potentially hazardous situation that, if not avoided, may result in minor or moderate injury. It may also be used to alert against unsafe practices.

You are responsible for the safe operation of your Pelsue #6759 Work Umbrella. You must ensure that anyone who will operate or work around the shelter be familiar with the proper Safe Operating Procedure. This manual will take you step-by-step through the workings and capabilities of the #6759 Umbrella and alert you to good safety and operating practices while using the system.

Remember, you are the key to safety. Good safety practices not only protect you but also the people around you. Make these practices a working part of your safety program. Be certain that everyone operating in or around a confined space is familiar with the procedures recommended and follows safety precautions. Remember, most accidents can be prevented. Do not risk injury or death by ignoring good safety practices.

- The most important safety device on this equipment is a safe operator. It is the operator's responsibility to read and understand all of the safety and operating instructions presented within this manual and to follow them. Most accidents can be avoided.
- A person must understand the operation of this equipment and be trained in its usage before operating the equipment. An untrained operator exposes himself and others to possible serious injury or death.
- Do not modify the equipment in any way. Unauthorized modification may impair the function and/or safety and could affect the life of the equipment.
- Think SAFETY! Work SAFELY!

4.1 - Safety Alert Symbol

SAFETY ALERT SYMBOL

This Safety Alert symbol means **ATTENTION! BECOME ALERT! YOUR SAFETY IS INVOLVED!**

The Safety Alert symbol identifies important safety messages on your Pelsue Product and in the manual. When you see this symbol, be alert to the possibility of personal injury or death. Follow the instruction in the safety message.



Why is this symbol important to you?

- 3 BIG Reasons:**
- Accidents Disable and Kill.**
 - Accidents Cost You Money.**
 - Accidents Can Be Avoided.**

Safety Precautions:

It is necessary to follow these safety precautions, each time, prior to using the product.

The Safety Precautions are not limited to, but must include the following items;

- 1.** Do not use the shelter for anything other than its intended use.
- 2.** Loose fabric may become caught in rotating machinery; if operating a ventilator, heater/blower, or any other equipment with spinning parts, be sure that adequate clearance is given between the Umbrella and rotating equipment, especially during set-up and take-down.
- 3.** The fabric of the Umbrella is flame resistant, however, exposure to flame or spark may cause it to ignite. Never allow a fire near, or impose residual sparks on the Umbrella. Do not smoke while under the Umbrella.
- 4.** Prevent any fumes from any internal combustion engines (such as a vehicle or generator) from entering the Umbrella. The open sides can lead to a false sense of ventilation. Any warm exhaust fumes will rise, and be trapped in the dome.
- 5.** Similarly, do not store any solvents or petroleum products under the Umbrella; the fumes are noxious and the danger of explosion from accumulation of volatile gases is severe.
- 6.** Since weather is unpredictable, the user must incorporate their own good judgement, common sense, and knowledge of local conditions with the installation instructions. The installer is responsible for anticipating weather severity for proper time and method of installation.



! CAUTION ! - The clearances between the tent rods, rod ends, and central hub are very tight. Use care when placing hands to deploy and take-down the Umbrella. Avoid holding the rods near the hub to eliminate the chances of pinching or trapping fingers.

! CAUTION ! - The tent rods are in significant tension when the tent is deployed. They have potential energy stored in their curvature which could result in a rapid motion if their restraints were removed. Never cut or deteriorate the rod pockets or cable ties associated with the rods.

! CAUTION ! - The Umbrella will be deployed overhead, and there are inherent risks in overhead work. Always be aware and use caution when working under equipment. During deployment and take-down, use caution to manually stabilize the support structure whenever both cups are not secured to the anchoring location. During operation, periodically check cups for positive suction.

5.0 - Product Operation

The following section will address the capabilities and the general operation of the Pelsue Model #6759 Work Umbrella. The instructions contained within this section should be adhered to each and every time the product is used. Any person tasked with installing or operating this piece of equipment should be familiar with these procedures.

5.1 - Product Description & Capabilities

The Umbrella is comprised of a support structure and a sewn assembly. Within the sewn assembly there is a roof, tent rods, and central support hub with threaded ball-lock. The roof is made of shade material, which is white on the outside, and black on the inside. This allows the Umbrella to provide ultra violet protection without blacking out all light. Computer screens which could not be read in direct sunlight are easily visible in the shade of the Umbrella. There is no need for an additional light source during daylight hours. The shade material also reduces solar heating effects, so the environment under the Umbrella should be cooler than ambient in sunny locations.

The support structure is based on securing two 4.5" diameter suction cups to a surface near the work area. Then a set of two hinges and one ball-hub allow the user to adjust the placement and orientation of the Umbrella in three axes, for full adjustability. The structure has been designed for ease of use, and can be installed and then broken down again in a matter of minutes. The minimum footprint required for the suction cups to adhere to is 5" wide by 10" high. The vertical alignment can be adjusted from 10" to 14" as situations may require. The cups do not need to be in vertical alignment because of the tilt adjustability.

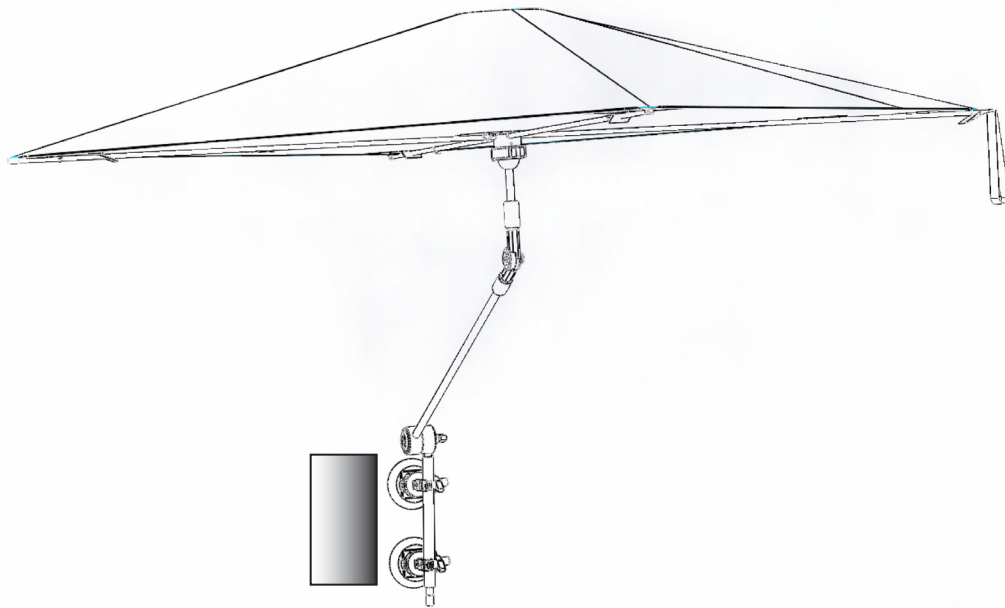

Figure #5.1a: #6759
Deployed Umbrella With Example 'Footprint'

5.2 - Set-Up, Operating, & Take-Down Procedures

Prior to Operation, the #6759 Work Umbrella should be configured and prepared according to the following guidelines.

It is necessary to perform a visual inspection, each time, prior to using the product. If deficiencies are found, remove the product from service and contact the T.A. Pelsue Company regarding repair. The following checklist coupled with *Figure #5.2a* should be used as a guide to determine whether the equipment is in good operating condition prior to usage. Equipment that is not in good condition can endanger the safety of the entrant(s) and attendant(s) during use.

The Pre-Operation Visual Inspection is not limited to, but must include the following items;

- a. Suction cup rubber base must be clean, free of debris, not cut or torn, and the round, white air filter must be in place. If these conditions are not met, positive hold will be diminished or impossible.
- b. Check rod & handle pockets (corners of the roof have reinforced nylon and webbing) for signs of wear or loose seams. These pockets are critical to tent tension and must be intact. Observe rod pocket locations in *Fig. 5.2a*.
- c. Two rubber straps connecting the suction cups to the fiberglass rod must be free of cracks or tears.

Set-Up of #6759 Work Umbrella with Vacuum Mount Suction Cups

Choose a location where installation will provide suitable protection to the work area, yet minimize obstructions during use. The suction cups require a smooth, clean surface (flat is not necessary). Mud, grease, or any form of grime must be wiped off before installation to ensure positive hold. Suction cups hold well on wet or dry surfaces. Once a location is chosen:

- a. Remove the Umbrella and support structure from the carry bag. The system consists of one complete assembly for the attachment interface and support structure, as well as a complete sewn assembly with integral tent rods and ball-hub.
- b. To start, determine the placement of the suction cups, abiding the notes about the surface condition listed above. Place the cups firmly against the desired mount location, and pump the white plunger shaft repeatedly until the red line is no longer visible. This red line is an indicator that the vacuum seal has diminished; to remedy, simply press the plunger again. Once the red line on the plunger is no longer visible, the cup is optimally secured.
- c. Repeat with the other suction cup.
- d. Loosen the handle on the toothed hinge by turning it counter-clockwise. This will allow the hinge to spin 360 degrees, so use caution that the assembly does not rotate and strike the operator or others present. The shaft has been fixed so as to only allow a maximum gap of about 1/4"; do not attempt to force the hinge open any further. Place the upper section of the assembly where appropriate, then tighten the handle fully, engaging the teeth completely.
- e. The other hinge operates on a push button. This hinge has 220 degrees of travel. Use this hinge to orient the uppermost rod at the final angle desired (roughly vertical is recommended).
- f. Now the sewn assembly can be attached. With the black surface facing the operator, grab the rod which is attached at only one end - taking caution to avoid the hub to avoid injury - then pull out and down on the red handle while pushing up on the rod. Slip the end of the loose rod into the pocket of the red handle.
- g. Finally, place the hub of the Umbrella onto the white ball at the top of the assembly; spin the collar onto the hub.
- h. The ball hub is designed to auto-level the roof, but it can be adjusted to tilt manually. Once the orientation is as desired, hand-tighten the collar to secure the Umbrella to the structure.

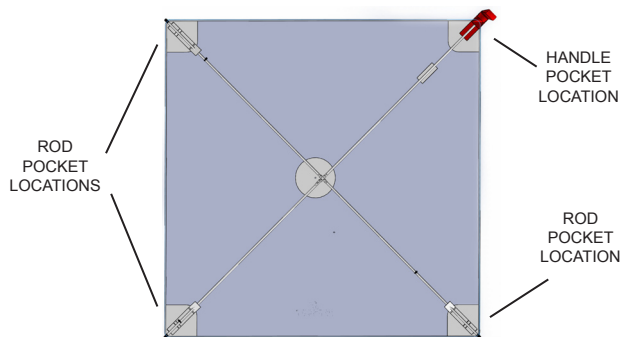

Figure #5.2a: #6759 Roof, Support Structure Omitted for Clarity

Important Notes:

- The positive hold of the cups must be maintained throughout operation. Periodically check the red line indicator for vacuum, and press the plunger as necessary to maintain. Different surfaces and surface conditions will determine the frequency required.
- The handles on the cup mounting brackets may be loosened to rotate the entire support structure. Ensure that they are tightened before operation to avoid unwanted movement of the tent.

5.2 - Set-Up, Operating, & Take-Down Procedures (continued)

Take-Down of #6759 Work Umbrella with Vacuum Mount Suction Cups

The dismantling of the Umbrella involves some overhead work, as the tent is located above the user. Always use caution and remain aware of surroundings when working with objects above.

- a. Remove the Umbrella from the support structure by spinning collar on ball-hub counterclockwise. Use caution that the roof does not catch wind and take flight. The collar is permanently locked onto the fiberglass rod, it can be left as is, ready for the next use.
- b. Pull out and push up on the red handle, slipping the fourth tent rod out of the integral red handle pocket. Now the whole sewn assembly can be folded up, with the four tent rods gathered together. Allow to dry, then place in the carry case.
- c. Loosen the handle on the toothed hinge by turning it counter-clockwise. This will allow the hinge to spin 360 degrees, so use caution that the assembly does not rotate and strike the operator or others present. The shaft has been fixed so as to only allow a maximum gap of about 1/4"; do not attempt to force the hinge open any further. Position the upper section of fiberglass rod to be aligned with the section for the suction cups. Then tighten the handle fully, engaging the teeth completely. Leaving the hinge in an open position during storage could lead to bending of the shaft.
- d. Now press the button on the other hinge and align that final section of fiberglass rod with the other two.
- e. Release the suction cups by locating the rubber nibs on opposing sides of the cup (at the base, see *Fig. 5.2b*) and pulling them towards the center, and each other. The cups will fall off, so use one hand to support the structure.
- f. Replace the red protective disks on the rubber bases of the cups for longer life-span.
- g. Store the support structure in the carry bag with the Umbrella. Be sure that the fabric has an opportunity to dry fully before being put into storage. If the sewn assembly is wet before storage, and does not dry adequately, mold, mildew, and rot can take hold, causing eventual fabric failure as well as possible health issues.

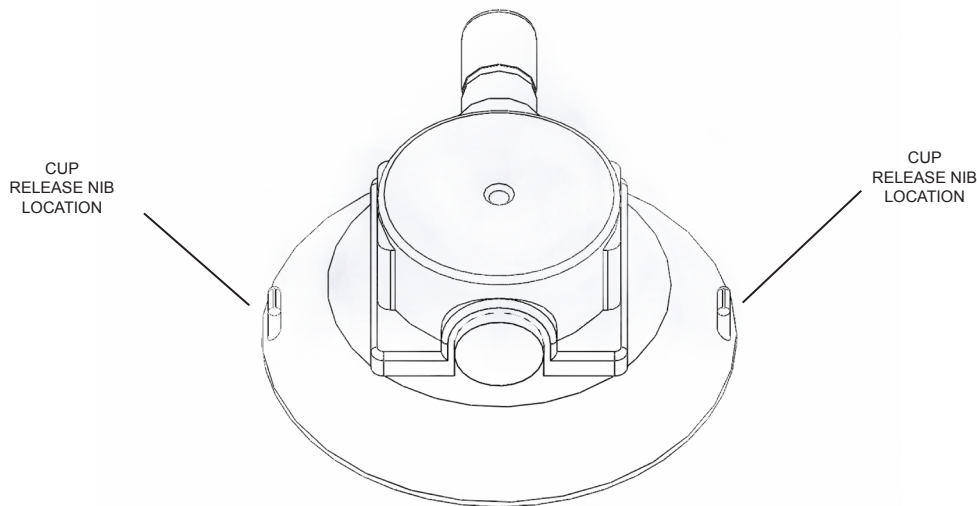

Figure #5.2b: Location of cup nibs for release of vacuum mount.

Notes:



T.A. Pelsue Company

2500 South Tejon Street, Englewood, Colorado, USA 80110
Toll free 800-525-8460 or 303-936-7432 Fax. 303-934-5581
Internet: www.pelsue.com Email: sales@pelsue.com