

Part #501169-001

Product Manual:

**“AC-R” Series Anchor Clamps for Round Manways
[Provides Fall Arrest Tower Mounting]**



PELSUE®
ISO 9001 Certified

T.A. Pelsue Company
2500 South Tejon Street
Englewood, Colorado, USA 80110
Tel. 800-525-8460 or 303-936-7432
Fax. 303-934-5581
Internet: www.pelsue.com
Email: sales@pelsue.com

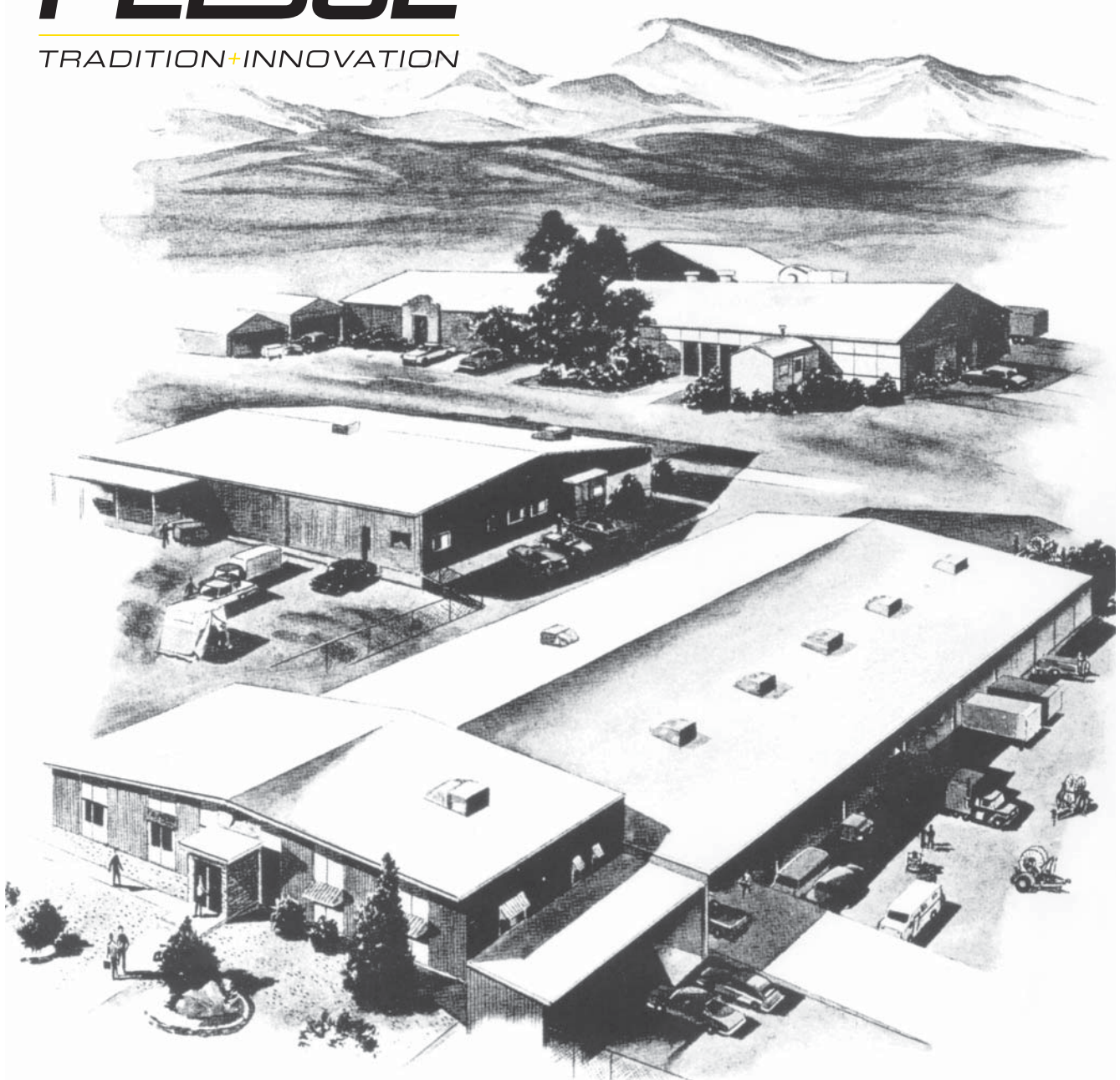

Since our inception in 1963 – the T.A. Pelsue Company has designed and manufactured high quality equipment to improve the personnel efficiency and working conditions in various underground, confined, and outdoor areas.

Founded by T. Allen Pelsue, the company has established a continuing reputation for excellence in the production of fine products for a broad spectrum of industry throughout the world.

Now, in our second generation of family direction, continued commitment to innovation and quality makes Pelsue a leading source of equipment for many types of confined spaces. We specialize in safety, retrieval, fall arrest, ventilation, cable placing, splicing, and maintenance nationally and abroad. With more than 70,000 square feet of facilities available, Pelsue continues the dedication that has made us pre-eminent in this field.

Table of Contents

Section	Description	Page #
1.0	General Information	5
1.1	Quality Policy	
1.2	Pelsue Product Warranty	
2.0	Introduction & Product Information	7
2.1	Serial Number	
3.0	Configuration & Assembly	8
4.0	Safety	9
4.1	Warning Statement	
4.2	Safety Alert Symbol	
4.3	General Safety Information	
4.4	Operating Safety	
4.5	Maintenance Safety	
4.6	New Operator Safety Information	
5.0	Product Operation	12
5.1	Product Description & Capabilities	
5.2	Product Installation & Set-Up	
6.0	Maintenance & Inspection	18
6.1	Maintenance	
6.2	Inspection	
6.3	Inspection Log	
7.0	Storage	22
8.0	Contact Information	22

1.0 General Information

1.1 Quality Policy

T.A. Pelsue Company

Quality Policy

OUR GOAL IS THE PURSUIT OF NEVER-ENDING IMPROVEMENT IN PRODUCT QUALITY AND BUSINESS SYSTEMS.

METHODS TO BE EMPLOYED IN ATTAINING THIS GOAL WILL INCLUDE NEW PRODUCT QUALITY PLANNING, EMPLOYEE TRAINING, AND UTILIZATION OF EMPLOYEE INVOLVEMENT GROUPS TO SOLVE PROBLEMS.

IN AN INCREASINGLY COMPETITIVE MARKETPLACE, ENSURING CUSTOMER SATISFACTION IS ONE OF THE DIFFERENTIATORS THAT SETS YOU APART FROM THE PACK AND YIELDS A COMPETITIVE ADVANTAGE.

THEREFORE, WE WILL SUPPORT TOTAL CUSTOMER SATISFACTION BY IMPLEMENTING THE **ISO 9001 QUALITY SYSTEM** AND PROVIDING THE NECESSARY ATMOSPHERE AND TRAINING TO NURTURE THIS CONCEPT THROUGHOUT OUR ORGANIZATION.

WE WILL MAKE EVERY BUSINESS DECISION AS THOUGH THE QUALITY OF THE PART OR SERVICE PROVIDED WAS DESTINED FOR OUR OWN OR OUR FAMILY'S USE. WE WILL ALWAYS THINK **QUALITY FIRST**.

EVERY T.A. PELSUE COMPANY EMPLOYEE IS EXPECTED TO COMMIT TO THIS PHILOSOPHY IN THE PERFORMANCE OF HIS OR HER DAILY TASKS.

QUALITY FIRST!

T.A. PELSUE COMPANY SENIOR MANAGEMENT TEAM

1.0 General Information (continued)

1.2 - Pelsue Product Warranty

PELSUE FALL ARREST/ RETRIEVAL PRODUCT WARRANTY

- Pelsue products are designed and engineered to perform as stated in published specifications. Quality materials and workmanship are used in the manufacture of this product. With regular maintenance and proper care, Pelsue equipment provides many trouble free hours of operation.
- The T.A. Pelsue Company warrants to the buyer that material furnished will conform to specifications and will be free from defects in material and workmanship from the date of shipment to the original buyer, for the period listed by product description at the bottom of this warranty statement.
- In the event of failure of any components of a Pelsue product within the warranty period, service must be pre-approved by the T.A. Pelsue Company and service must be performed by the T.A. Pelsue Company Parts and Service Department in Englewood Colorado, or at the option of T.A. Pelsue Company, service may be performed at any designated service center, which may include any authorized service center for the component manufacture.
- Damage or failure due to misuse, mishandling, or unauthorized modifications will not be covered by this warranty. Unless otherwise agreed, the T.A. Pelsue Company shall repair or replace the defective components within (30) calendar days of notice of failure. T.A. Pelsue Company's obligation hereunder, shall be limited to the repair or replacement of the product or component as set forth above, and shall not include any liability whatsoever for damages caused by such failure, including but not limited to consequential or incidental damages flowing from use or lack of use of product.
- Any replacement, repair, modification, installation or other service performed by the T.A. Pelsue Company shall be warranted by the remainder of the unexpired period of the warranty, or for a period of (90) calendar days, whichever is longer.
- All materials or parts returned for credit or warranty shall be returned only with prior approval, and will be subject to factory inspection before credit is allowed. Parts claimed defective will be replaced upon request and will be invoiced as purchased, subject to credit when the parts claimed to be defective have been received and examined by the factory.
- This warranty is expressly in lieu of all other warranties expressed or implied, including any warranties of merchantability or warranties of fitness for any particular use and all other obligations or liabilities in connection with the sale of this equipment.

<u>Product Description</u>	<u>Warranty Coverage*</u>
• Davits and Bases, Life Guard Systems, Fall Arrest Towers,..... Hitch Mounts, Mounting Sleeves	1 year
• Winches.....	1 year
• Winch Cable and Rope (not including standard wear and..... tear or misuse or improper storage)	3 months
• Rope.....	3 months
• Pelsue Painted or Plated Surfaces.....	1 year

*From date of shipment to original buyer.

T.A. Pelsue Company, 2500 South Tejon Street, Englewood, Colorado 80110, 800-525-8460

2.0 - Introduction & Product Information

Congratulations on your choice of a **Pelsue AC-R Series Anchor Clamp** to compliment your fall arrest system. This equipment has been designed and manufactured to exceed fall arrest requirements and regulations in order to meet the needs of the discriminating operator.

Safe, efficient and trouble-free operation and maintenance of the system requires that anyone who will be operating, maintaining, or inspecting the equipment, read, understand and follow all of the operation, safety, maintenance, and inspection instructions contained within this manual. This manual is applicable to all Pelsue AC-R Series Anchor Clamps. Use the Table of Contents as a guide to find specific information.

Keep this manual available for future reference and for usage as a tool in the instruction of new operators. Establish a regular training program for all operators. Establish a regular maintenance and inspection program to keep the equipment in top condition.

⚠ WARNING

This product is a part of a complete Fall Arrest system. The user must read, understand and follow the instructions contained in this manual for each component or total system before using this equipment. Establish an appropriate training, maintenance and inspection program for your people and the equipment. Failure to follow these instructions could result in serious injury or death.

2.1 - Serial Number

Product Serial Number

Always give your dealer the serial number of your Pelsue Fall Arrest product when ordering parts or requesting service or other information.

The serial number decal is permanently embossed with a serial number. The serial number decal will appear as shown in *Figure 2a* at the right and is located on the side of the beam clamp (see *Figure 2b*). A space has been provided below for the recording of the serial number for future reference.

S/N#	_____
MODEL#	_____
DOM	_____

Figure 2a:
Serial Number Decal

MODEL: **#AC-** _____

Serial Number : _____

Date of Manufacture (DOM): _____

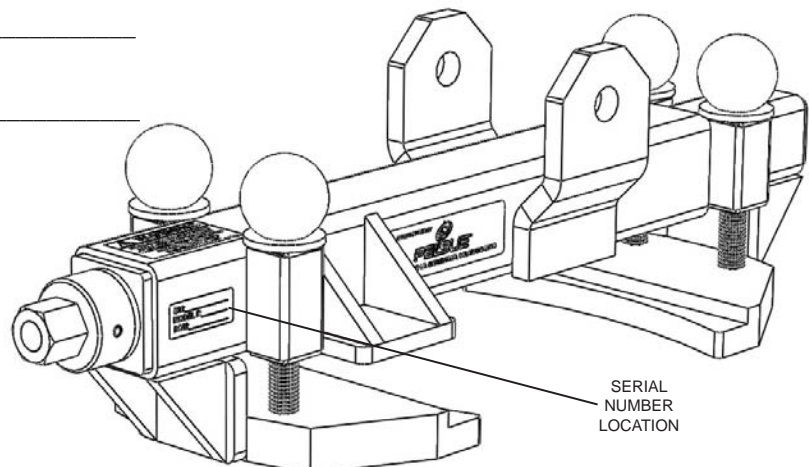

Figure 2b:
Serial Number Decal Location

3.0 - Configuration & Assembly

Upon initial receipt of the #AC-R Series Device, inspect the packaging for any evidence that the product may have been damaged in shipment. While unpacking the product, inspect all of the components for damage. If damage to any of the components is discovered, DO NOT USE THE PRODUCT! Alert the shipping carrier immediately of the damage to the shipment.

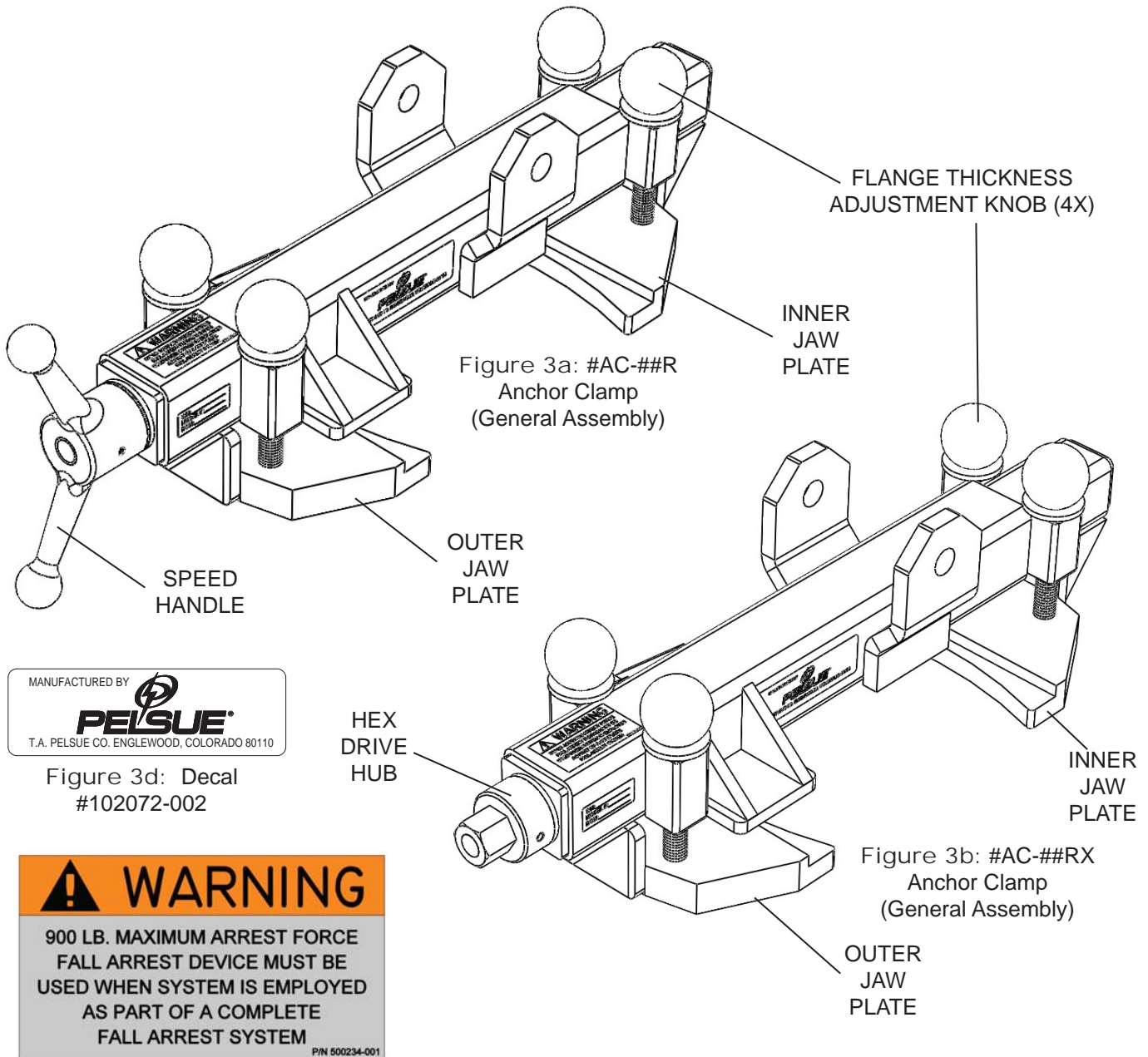

Figure 3a: #AC-##R
Anchor Clamp
(General Assembly)

FLANGE THICKNESS
ADJUSTMENT KNOB (4X)

INNER
JAW
PLATE

SPEED
HANDLE

OUTER
JAW
PLATE

MANUFACTURED BY
PELSUE
T.A. PELSUE CO., ENGLEWOOD, COLORADO 80110

Figure 3d: Decal
#102072-002

HEX
DRIVE
HUB

INNER
JAW
PLATE

Figure 3b: #AC-##RX
Anchor Clamp
(General Assembly)

OUTER
JAW
PLATE

WARNING

900 LB. MAXIMUM ARREST FORCE
FALL ARREST DEVICE MUST BE
USED WHEN SYSTEM IS EMPLOYED
AS PART OF A COMPLETE
FALL ARREST SYSTEM

P/N 500234-001

Figure 3e: Decal
#500234-001

Verify that all parts are present before product use.

The AC-R Series Anchor Clamp is shipped fully assembled.

1. Ensure that the product has been shipped with all the necessary components and is in working order (Refer to Fig. #3a or #3b)

**Refer to the Figures above to determine if replacement parts are required. Replacement parts can be obtained from the T.A. Pelsue Company at 800-525-8460.

4.0 - Safety

The following section will address the safety precautions which must be adhered to when working with Pelsue Fall Arrest equipment such as the AC-R Series Anchor Clamps. Any user must familiarize themselves with the information in this section before utilizing the equipment.

SIGNAL WORDS:

Note the use of the signal words **DANGER**, **WARNING** and **CAUTION** with the safety messages. The appropriate signal word for each message has been selected using the following guidelines:

- DANGER-** Indicates an imminently hazardous situation that, if not avoided, will result in death or serious injury. This signal word is to be limited to the most extreme situations or for hidden or unseen hazards.
- WARNING-** Indicates a potentially hazardous situation that, if not avoided, could result in death or serious injury and includes obvious and hidden hazards. It may also be used to alert against unsafe practices.
- CAUTION-** Indicates a potentially hazardous situation that, if not avoided, may result in minor or moderate injury. It may also be used to alert against unsafe practices.

You are responsible for the safe operation, maintenance and inspection of your Pelsue AC-R Series Anchor Clamp. You must ensure that anyone who will operate, maintain, inspect or work around the equipment be familiar with the operating and maintenance procedures and related safety information contained in this manual. This manual will take you step-by-step through the workings and capabilities of the AC-R Series Anchor Clamp and alert you to all good safety and operating practices while using the system.

Remember, you are the key to safety. Good safety practices not only protect you but also the people around you. Make these practices a working part of your safety program. Be certain that everyone operating this equipment is familiar with the procedures recommended and follows safety precautions. Remember, most accidents can be prevented. Do not risk injury or death by ignoring good safety practices.

- System owners must give operating instructions to operators or employees before allowing them to use the equipment and at least annually thereafter.
- The most important safety device on this equipment is a safe operator. It is the operator's responsibility to read and understand all safety and operating instructions in the manual and to follow those guidelines. Most accidents can be avoided.
- A person must understand the operation of this equipment and be trained in its usage before operating the equipment. An untrained operator exposes himself and others to possible serious injury or death.
- Do not modify the equipment in any way. Unauthorized modification may impair the function and/or safety and could affect the life of the equipment.
- Think SAFETY! Work SAFELY!

4.1 - Warning Statement

WARNING!

Products manufactured or sold by the T.A. Pelsue Company are intended for use by professionals trained and experienced in the use, inspection and maintenance of these products.

Paraprofessional users such as volunteer rescue workers and sportsmen involved in risk sports such as climbing and caving will be held to the same standard of experience and training as professionals.

Technical rescue, repelling, climbing and the training involved are hazardous activities. Each situation has its own unique conditions and must be evaluated. Effective risk management comes from experience, proper training and good personal judgement.



4.2 - Safety Alert Symbol

SAFETY ALERT SYMBOL

This Safety Alert symbol means **ATTENTION! BECOME ALERT! YOUR SAFETY IS INVOLVED!**

The Safety Alert symbol identifies important safety messages on your Pelsue Retrieval Product and in the manual. When you see this symbol, be alert to the possibility of personal injury or death. Follow the instruction in the safety message.



Why is this symbol important to you?

3 BIG Reasons: Accidents Disable and Kill.

Accidents Cost You Money.

Accidents Can Be Avoided.

4.3 - General Safety Information

1. Read, understand, and follow the Product Manual and all safety signs before using, maintaining or inspecting the equipment.
2. Refer to and follow applicable standards and regulations. Comply with requirements of local regulations for your applications.
3. Establish an equipment-use training program for inexperienced employees. Only trained, competent persons shall use the equipment. An untrained operator is not qualified to operate the system.
4. Have a first-aid kit available for use should the need arise and know how to use it.
5. Provide a fire extinguisher for use in case of an accident. Store in a highly visible place.
6. Install and properly secure all guards and shields before operating.
7. Wear appropriate protective gear. This list includes but is not limited to:
 - A hard hat
 - Protective shoes with slip resistant soles
 - Heavy gloves
 - Protective clothing
 - Face Protection
8. Review and follow the Pre-Operation Checklist before using a component in the system or system itself.
9. Establish a regular maintenance and inspection program with your equipment and maintain detailed records.
10. Review safety related items and operating instructions with all personnel on a regular basis.

4.4 - Operating Safety

1. Read, understand and follow the Product Manual as well as all printed warnings that may be located on the product itself before using, maintaining or inspecting the equipment.
2. Train all operators before allowing them to use the product. An untrained operator exposes themselves, bystanders and workers to possible serious injury or death.
3. Visually inspect the product and all auxiliary components and equipment before using. Correct any problems before using the equipment.
4. Securely anchor the product before using.
5. Use only certified anchor and connector components in your system.
6. Use only an approved full body harness for the workers.

4.4 - Operating Safety (continued)

7. Always work in teams. When working upon an elevated surface where a fall is possible, making a subsequent rescue necessary, personnel must be available and ready for rescue immediately. Working alone with this equipment is inherently dangerous and not advised!
8. Do not exceed the capacity of the system at any time (see section 5.1).
9. Establish a regular training program for all operators and potential rescuers.
10. Establish a detailed inspection program for your equipment and document the findings. Return the equipment to the manufacturer for repair if any problems are found.
11. Plan your work program before starting. Have the required people, equipment and procedures readily available in order to safely complete any task prior to commencing.
12. Do not use the equipment around physical or environmental hazards. This list includes but is not limited to:
 - Corrosion that may affect the structural integrity of the lifeline or other components.
 - Chemicals which can degrade components in a manner which can not be visually identified.
 - Toxic gases: Rescuers or workers can be killed in toxic environments.
 - Heat or elevated temperatures.
 - Moving machinery: Workers or auxiliary equipment can be contacted by or pulled into moving components.
 - Sharp edges: Workers or the rescue equipment can be injured by or damaged by sharp edges or components.
 - Electrical hazards: Stay away from power lines or components carrying electrical power.
 - Overload: Do not overload the system at any time during operation (see section 5.1).
 - Follow elevated space regulations and standards.

4.5 - Maintenance Safety

1. Read, understand and follow the Product Manual as well as any printed warnings that may be present on the product before using, maintaining or inspecting the equipment.
2. ANSI and OSHA require a regular inspection program for all fall arrest equipment as well as properly-documented results of the inspections. Follow the inspection procedures contained in this manual and use the inspection form to document the results (see section 6.0).
3. Keep instructional and safety signs clean and legible at all times. Clean or replace as required.
4. Remove the equipment from service if a problem is found during the inspection. Return to an authorized repair depot or the factory for service.

4.6 - New Operator or Owner

The Pelsue AC-R Series Adjustable Anchor Clamp for Round Manways is designed as a portable Base System for a Pelsue Model #FT-C70 fall arrest tower. Every new operator must read, understand and follow the instructions in this Product Manual. No person should be permitted to use the equipment without prior proper training. The training should be reviewed with experienced operators on a regular basis. At regular intervals, perform a detailed inspection of the equipment and document the results. Remove the product from service if any deficiencies are found. Alterations or misuse of this equipment or failure to follow instructions may result in serious injury or death.

It is the responsibility of the owner's organization to ensure that the proper training is provided to all operators of any fall arrest device before they start working with the equipment. Follow all safety instructions exactly. Safety is everyone's business. By following recommended procedures, a safe working environment is provided for the operator, bystanders and the area around the work site. Untrained operators are not qualified to operate the equipment.

Many features incorporated into this equipment are the result of suggestions made by customers like you. Read this manual carefully to learn how to operate & install the equipment safely and as intended. By following the operating instructions in conjunction with a good maintenance program, your product will provide many years of trouble free service.

5.0 - Product Operation

The following section will address the capabilities and the general operation of the Pelsue AC-R Series Anchor Clamp. The instructions contained within this section should be adhered to each and every time the product is used. Any person tasked with installing or operating the piece of equipment should be familiar with these procedures.

5.1 - Product Description & Capabilities

The Pelsue AC-R Series Anchor Clamp is constructed from carbon steel & incorporates high-strength alloy steel hardware. The AC-R Series Anchor Clamp is specifically designed to provide a compliant mounting point for a Pelsue Model #FT-C70 Fall Arrest Tower. All specifications, instructions, and procedures provided within this manual or upon Pelsue Specification Documents are based upon and only valid for usage with a Pelsue #FT-C70 Fall Arrest Tower. The T.A. Pelsue Company can not verify equipment safety and/or compliance when utilized with anything other than Pelsue-approved AC-R Series Anchor Clamp complementary products.

General Specifications:

Designed for a clamping attachment to round flanged manway entries commonly found in industrial locations

- Minimum Manway Flange Diameter: 16" (AC-28R & AC-28RX)
19" (AC-34R & AC-34RX)
- Maximum Manway Flange Diameter: 28" (AC-28R & AC-28RX)
34" (AC-34R & AC-34RX)
- Product Weight: 55 LBS. (AC-28R & AC-28RX)
59 LBS. (AC-34R & AC-34RX)

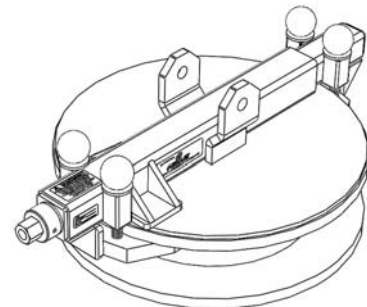

Figure #5a: AC-R Series Installed on a Manway (Minimum Diameter)

Compliance & Rating:

- Fall Arrest Tower Mounting: The AC-R Tower Mounting Ears provide a compliant mounting point for a Pelsue Model #FT-C70 Fall Arrest Tower when the tower is installed and utilized per the published requirements.

Other Requirements:

- It is the user's responsibility to ensure that the structure to which the AC-R Clamp is attached is capable of withstanding the loads imparted to it by a proof-loaded system in order to retain stated compliance. *Refer to the loading diagrams located within this section for required information*
- The AC-R Clamp is only to be used in conjunction with a Pelsue Model #FT-C70 Fall Arrest Tower, the system must be employed according to the requirements and limitations of both the anchor clamp and the fall arrest tower.

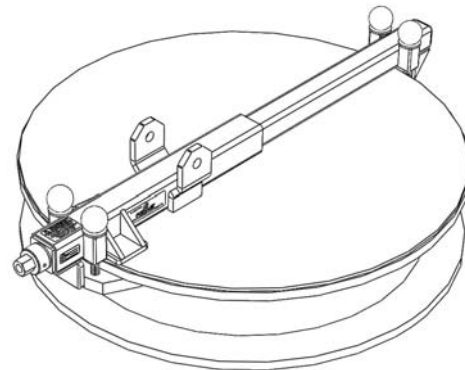

Figure #5b: AC-R Series Installed on a Manway (Maximum Diameter)

Materials & Construction

- Main Structure - Carbon Steel
- Hardware - Alloy Steel



The load ratings presented here may supersede or be superseded by the capabilities of an installed accessory. The rating of a complete fall arrest system can only be rated to the capabilities of its lowest-rated component.



! WARNING ! - The user must ensure that the manway and structure to which the AC-R Series Clamp is attached is capable of withstanding all of the loads imparted to it by the device when proof-loaded. There is a limitless variety of structural configurations possible and addressing each potential scenario is beyond the scope of this manual. A "qualified person" must approve each attachment point.

! WARNING ! - The user must ensure that all adjustment points and fasteners are properly secured in order to retain the stated compliance of the entire system.

5.1 - Product Description & Capabilities (continued)

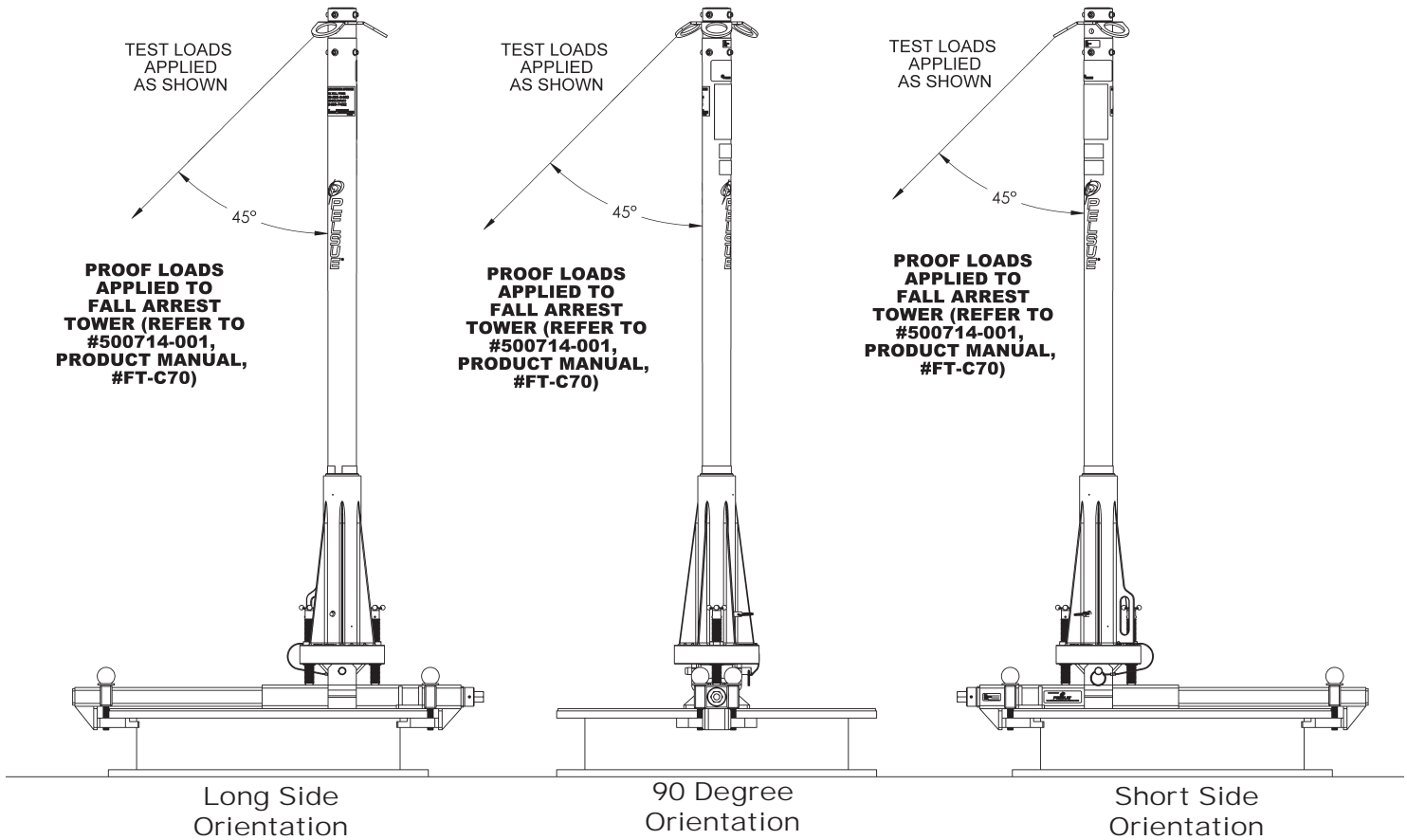

Figure #5c: AC-R Series Anchor Clamp, Testing & Loading Diagram

5.2 - Product Installation & Set-up

Prior to Operation, the AC-R Series Anchor Clamp doe Round Manways must be configured and installed according to the following guidelines.

1. Pre-Operation Inspection:

It is necessary to perform a visual inspection prior to each time using the product. If any deficiencies are found, remove the product from service and contact the T.A. Pelsue Co. regarding repair. The following checklist coupled with *Figure #5.2a* should be used as a guide to determine whether the equipment is in good operating condition prior to usage. Equipment that is not in good condition can endanger the safety of the operators during use.

The Pre-Operation Visual Inspection is not limited to, but must include the following items;

- a. Check that the product has no structural defects, such as dents, bends, cracks, or fractures. Check for elongation of the holes in the Tower Mounting Ears.
- b. Ensure that all product decals are clear and legible.
- c. Ensure that the Hex Drive Hub or Speed Handle turns freely and that the width of the clamp opens and closes as intended (binding in the width adjustment may be indicative of further damage).
- c. Ensure that the 4X Flange Thickness Adjustment Knobs turn freely and that the jaw plates move up and down as intended (binding in the adjustment knobs or jaw plates may be indicative of further damage).

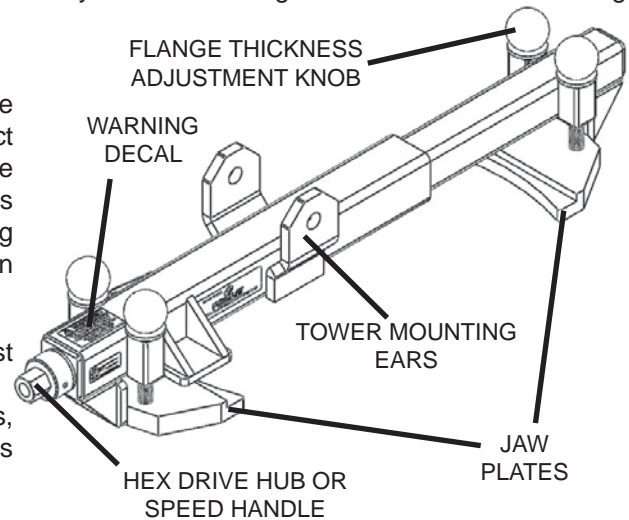

Figure #5d: AC-R Series Pre-Operation Inspection Points

5.2 - Product Installation & Set-up (continued)

2. Installation of the AC-R Series Anchor Clamp for Round Manways:

- a. Choose a location where installation will provide suitable proximity to the work area yet minimize obstructions during use and in the event a rescue is necessary. Select a Round Manway that possesses dimensions which fall within the range(s) tabulated below;

Model Number	"D"		"T"	
	Minimum Manway Flange Outside Diameter	Maximum Manway Flange Outside Diameter	Minimum Flange Thickness	Maximum Flange Thickness
AC-28R	16.00	28.00	0.50	1.25
AC-28RX				
AC-34R	19.00	34.00	0.50	1.25
AC-34RX				

Table #5a: Range of Allowable Manway Dimensions for Safe Installation of AC-R Series Clamp

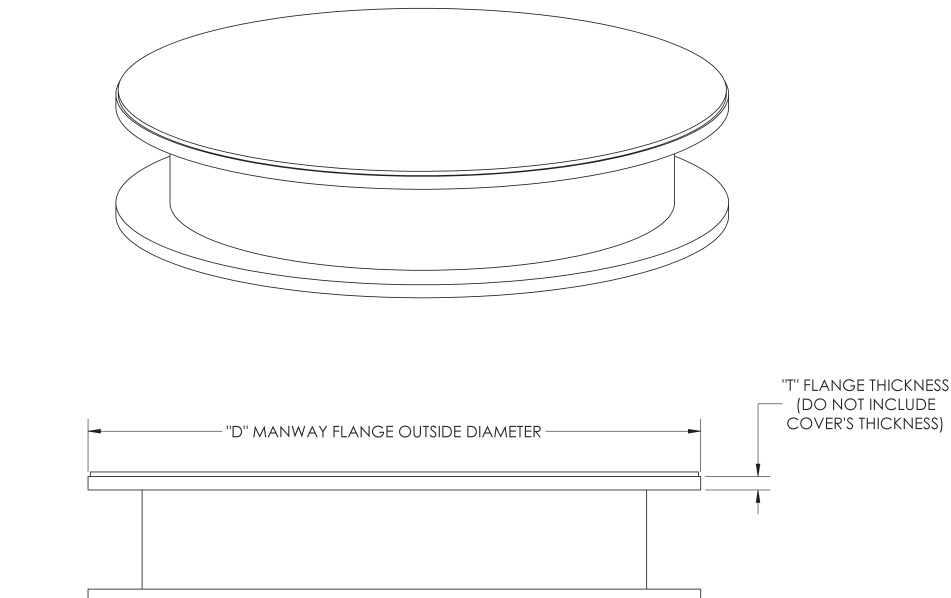

Figure #5e: Manway Diagram with Dimensional Definitions (typical, Round Construction)



! WARNING ! - The AC-R Series Anchor Clamp exhibits construction that allows it to extend beyond the dimensions of the "Maximum Manway Flange Outside Diameter". This is made possible in order to facilitate the installation of the device. As a result of this construction the AC-R Series clamp **CAN** physically mount on Manway structures which fall outside of the tabulated dimensions (refer to Table #5a). However, in order to retain product safety and compliance, the AC-R series clamp must only be installed on round manways which fall within the ranges published within Table #5a.

•When utilized as a Fall Arrest Tower Anchorage: Install The clamp so that the tower to be utilized will clear all obstructions yet provide full access to all required work areas within the towers's safe working radius.

**Once a location and manway have been chosen, Ensure that the Manway as well as the supporting structure to which the clamp will be attached is capable of withstanding all of the forces imparted to it by the proof-loaded system (Refer to Section 5.1 of this manual).

5.2 - Product Installation & Set-up (continued)

- b. Once a location is chosen for clamp installation, turn all 4X Flange Thickness Adjustment knobs and the Hex Drive Hub or Speed Handle counterclockwise such that the parts of the clamp open to a point where it can be placed over and around the manway structure.

! WARNING ! - The user must ensure that the manway and structure to which the AC-R Series Clamp is attached is capable of withstanding all of the loads imparted to it by the device when proof-loaded. There is a limitless variety of manway and structure configurations and addressing each potential scenario is beyond the scope of this manual. A “qualified person” must approve each attachment point.

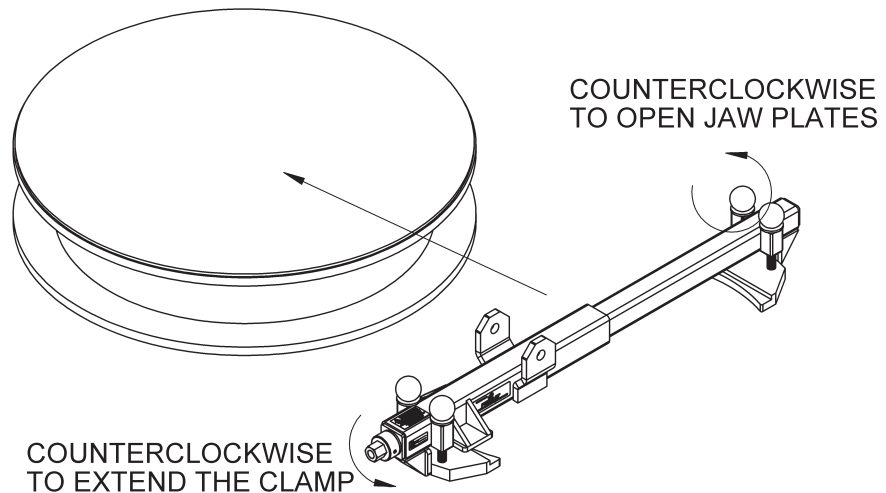

Figure #5f: Installation Step “b”

- c. Once positioned at the center of the manway structure, turn the Hex Drive Hub or Speed Handle Clockwise to pull the sections of the clamp together around the manway flange. The 4X vertical adjustment screws should just come into contact with the outside of the manway flange. Do not over tighten at this stage, or the threaded components could become damaged.

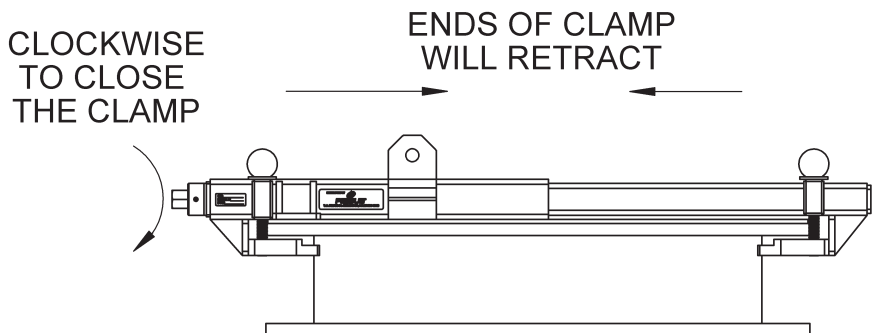

Figure #5g: Installation Step “c”

! WARNING ! Excessive tightening of the Hex Handle Hub/Speed Handle, especially if utilizing a powered tool for this step, can permanently damage the clamp and cause it to fail. The vertical screws only need to be brought close to the manway flange, they do not serve to “grip” the structure!

- d. Ensure that the 4X vertical adjustment screws are adjacent to the outside diameter of the manway flange. It should also be verified that the upper flat surface of each jaw plate is located underneath the manway flange. Simply placing the “notched” section of the jaw plates under the flange is not adequate. Bringing the vertical screws into “near” contact with the flange should ensure that the jaws are properly positioned (refer to Figure #5h for proper positioning).

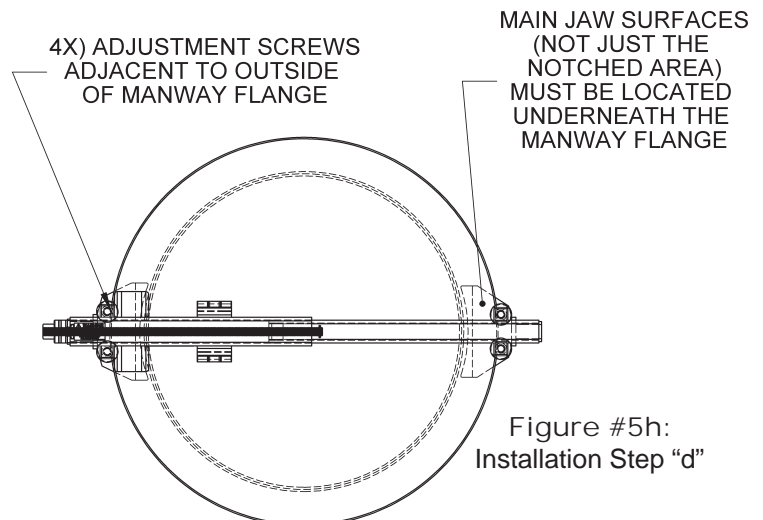

Figure #5h: Installation Step “d”

5.2 - Product Installation & Set-up (continued)

- e. Turn the 4X Flange Thickness adjustment knobs clockwise to bring the jaw plates into contact with the bottom face of the manway flange. Using only hand strength tighten the four knobs as much as possible to complete installation of the AC-R Series clamp. Check all adjustment points and ensure that the clamp is securely and properly installed before proceeding. It should not be possible to move the clamp without loosening the adjustments when the clamp is properly installed.



!WARNING! - The user must ensure that the AC-R Series Clamp is properly installed & securely clamped on the selected structure before attaching any life-line or additional fall arrest system components.

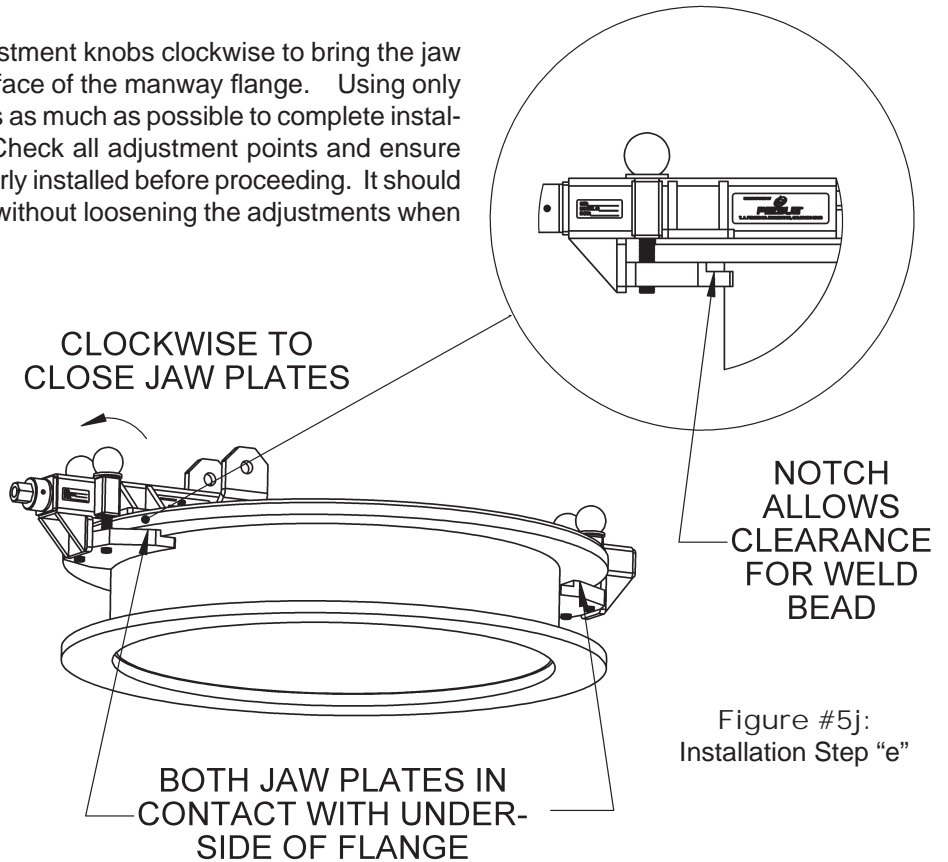

Figure #5j:
Installation Step "e"

3. Installation of an #FT-C70 Fall Arrest Tower on the AC-R Series Anchor Clamp:

- Install the AC-R Series Anchor Clamp according to the instructions in Step #2 of section 5.2 of this manual.
- Separate the #FT-C70 tower into its two major components (i.e. the Base Assembly, and the Tower Assembly)
- Center the tower base assembly over the tower mounting ears, placing the pin holes "in-line". Visually align the pin holes and insert the base securing pin completely through each ear and the tower base. The screw pegs may have to be adjusted on the base in order to allow alignment.

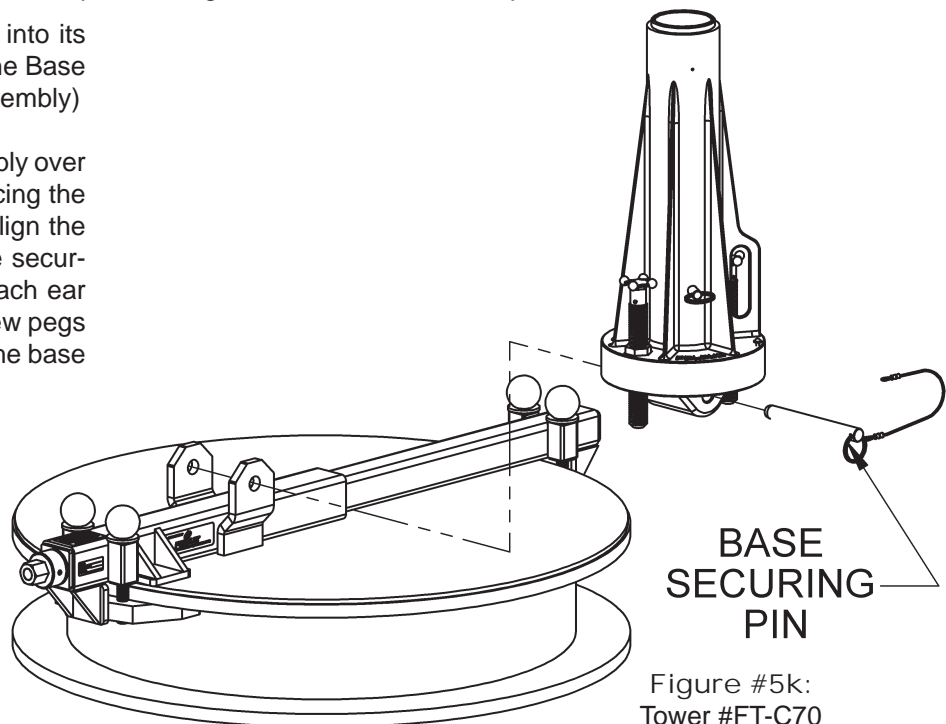

Figure #5k:
Tower #FT-C70
Installation Step "c"

5.2 - Product Installation & Set-up (continued)

- d. Insert the tower assembly into the installed base assembly, rotate by hand to align the pin holes, then lock the tower in place with the Tower Securing Pin
- e. Adjust the levelling pegs in order to place the tower in a vertical position (Refer to Fig. 5n). **! WARNING !** - The #FT-C70 fall arrest tower can only be used for the anchoring of personal fall arrest systems when placed in a vertical orientation. Check that all adjustments and fasteners are secure, then utilize the #FT-C70 Fall Arrest Tower according to its Product Manual (Refer to document #500714-001).

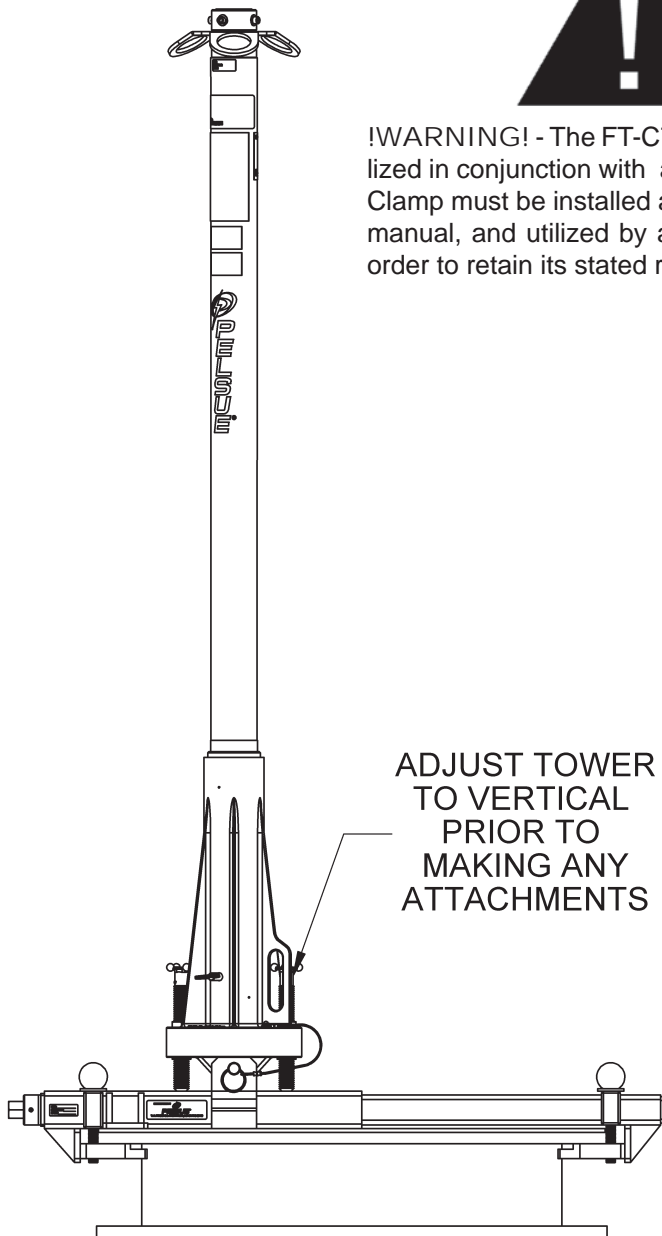

Figure #5n:
Tower #FT-C70 Installation Step "e"



!WARNING! - The FT-C70 Fall Arrest Tower utilized in conjunction with an AC-R Series Anchor Clamp must be installed according to its product manual, and utilized by a qualified individual in order to retain its stated rating & compliance.

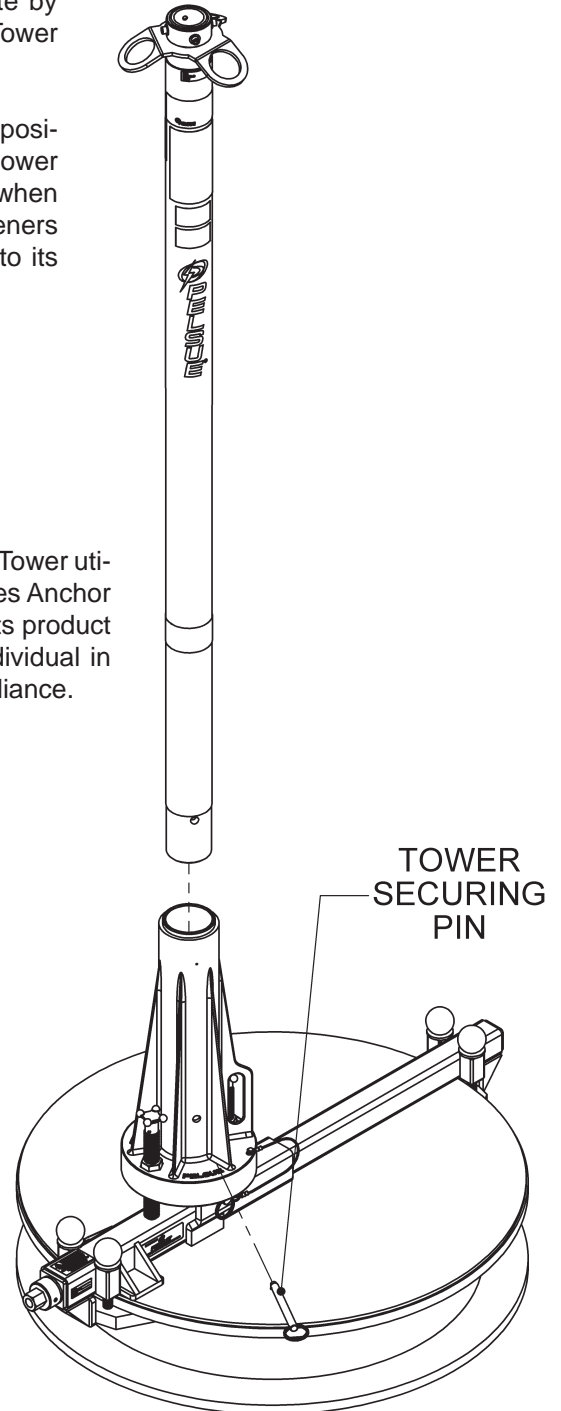

Figure #5m:
Tower #FT-C70
Installation Step "d"



!WARNING! - Any FT-C70 Fall Arrest Tower Attached to an AC-R Series Anchor Clamp must be utilized within its published limits and capabilities. The rating of the installed tower may supersede or derate the capabilities of the AC-R Series Clamp.

6.0 - Maintenance & Inspection



MAINTENANCE & INSPECTION

1. Read, understand and follow the Product Manual and signs on the product before using, maintaining or inspecting the equipment.
2. ANSI and OSHA require a regular inspection program for all fall arrest equipment and to maintain documented results of these inspections. Follow the inspection procedure contained in this manual and use the inspection form to document the results.
3. Keep instructional and safety signs clean and legible at all times. Clean or replace as required.
4. Remove the equipment from service if a problem is found during the inspection. Return to an authorized repair depot or the factory for service.

6.1 - Maintenance

For the most part, the AC-R Series Anchor Clamp is intended to be a maintenance-free piece of equipment, however several steps can be taken to keep the system in top-notch working order and also extend the working life of the product.

Before Each Use:

1. Visual Inspection: Perform a complete visual inspection. Refer to section 6.2 for guidelines and take any maintenance steps that are necessary.

Annually:

1. Clean Product: Use a damp cloth and mild soap to clean the structure and labels of dirt and residue. Be sure the labels are legible (replacements are available from Pelsue)
2. Lubricate all Threaded Components: Apply a water resistant lubricant suitable for high-strength steel fasteners to all threads in order to extend the working life of these components.
3. Complete Inspection: Perform a thorough inspection, paying attention to the bullet points provided within section 6.2. Record results and keep documentation. A log has been provided in section 6.3 specifically for the recording of the dates & results of annual system inspections.

Periodic Factory Service Inspection: It is recommended that the product be serviced by a factory authorized service center or the manufacturer after a period of three years. Extreme working conditions may make it necessary to increase the frequency of such an evaluation. Factory servicing shall include but not be limited to an intensive inspection and cleaning of all internal and external components. Failure to provide proper service may shorten product life and could endanger performance or function.

6.2 - Inspection

When completing an inspection of an AC-R Series Anchor Clamp, the following specific items should be checked;

1. Labels:

Check that all of the labels are clean and legible (Refer to Section 3.0). Clean the labels if any are dirty using mild soap and a damp cloth. Replace if any are illegible. Decals & labels provide valuable warning and caution information applicable to product usage and limitations, and should be visible and present at all times.

2. Tower Mounting Ears:

Visually inspect for any fracture or deformation. Overloading of the system can deform and damage the ears. Specifically check for "elongation" of the pin holes in the ears. The pin holes should be round with relatively sharp edges at the face of the ear. Any AC-R Series Anchor Clamp system exhibiting deformation in the ears should be removed from service immediately.

6.2 - Inspection (continued)

3. Structure:

The entire product structure should be checked for cracks, gouges, dents, bends or breaks. If there are dents or any other structural damage, the unit should be removed from service and returned to the factory for repair.

- Pay special attention to weld locations: look for cracks or separation at the welds. Keep in mind the nickel plating can age and scratch, this normal finish scratching can be confused with structural cracking. If there is any uncertainty with regards to cracks, contact the Pelsue service department for assistance and/or recommendations
- Ensure that the sections of the device can freely move and be adjusted as intended without interference. Binding or interference of any kind may be indicative of structural damage and must be cause for further inspection.

4. Threaded Adjustments:

Ensure that when turning the Hex Drive Hub or Speed Handle as well as the 4X Flange Thickness Adjustment Knobs, that they turn freely and that there is no binding in the movement of the parts. Visually check the condition of all of the threads on the adjustment screws. The threads must be clean, and free of any damage. If any stripped or flattened threads are observed anywhere on the product, it must be removed from service immediately.

6.3 - Inspection Log

Model Number : _____
Serial Number : _____
Date Purchased : _____
#AC- _____

Place a check (✓) in the box if item is acceptable, place an x (X) in the box if item requires maintenance or repair

Date	Labels	Tower Mounting Ears	Structure	Threaded Adjustments	Notes
Inspector (print & sign) :					
Inspector (print & sign) :					
Inspector (print & sign) :					
Inspector (print & sign) :					
Inspector (print & sign) :					
Inspector (print & sign) :					
Inspector (print & sign) :					
Inspector (print & sign) :					
Inspector (print & sign) :					

6.3 - Inspection Log (continued)

Place a check (✓) in the box if item is acceptable, place an x (X) in the box if item requires maintenance or repair

Date	Labels	Tower Mounting Ears	Structure	Threaded Adjustments	Notes
Inspector (print & sign) :					
Inspector (print & sign) :					
Inspector (print & sign) :					
Inspector (print & sign) :					
Inspector (print & sign) :					
Inspector (print & sign) :					
Inspector (print & sign) :					
Inspector (print & sign) :					

7.0 - Storage

Prior to storage, the product should be thoroughly inspected and maintained. Repair or replace any worn or damaged components to prevent any unnecessary down time at the next use.

Follow this procedure:

1. Thoroughly clean the entire unit using a mild soap on the frame and labels.
2. Perform a complete inspection of the unit and document the results prior to storage.
3. Ensure that the unit is completely dry prior to storage.

8.0 - Contact Information

For More Information...



T.A. Pelsue Company
2500 S. Tejon St.
Englewood, CO 80110

Toll Free: 1-800-525-8460
Telephone: 1-303-936-7432
Fax: 1-303-934-5581

Website: www.pelsue.com

Email: sales@pelsue.com



T.A. Pelsue Company
2500 South Tejon Street, Englewood, Colorado, USA 80110
Toll free 800-525-8460 or 303-936-7432 Fax. 303-934-5581
Internet: www.pelsue.com Email: sales@pelsue.com