

Part #501126-001

Product Manual:

Model #BC-08A
Adjustable Angle Beam Clamp



PELSUE[®]
ISO 9001 Certified

T.A. Pelsue Company
2500 South Tejon Street
Englewood, Colorado, USA 80110
Tel. 800-525-8460 or 303-936-7432
Fax. 303-934-5581
Internet: www.pelsue.com
Email: sales@pelsue.com

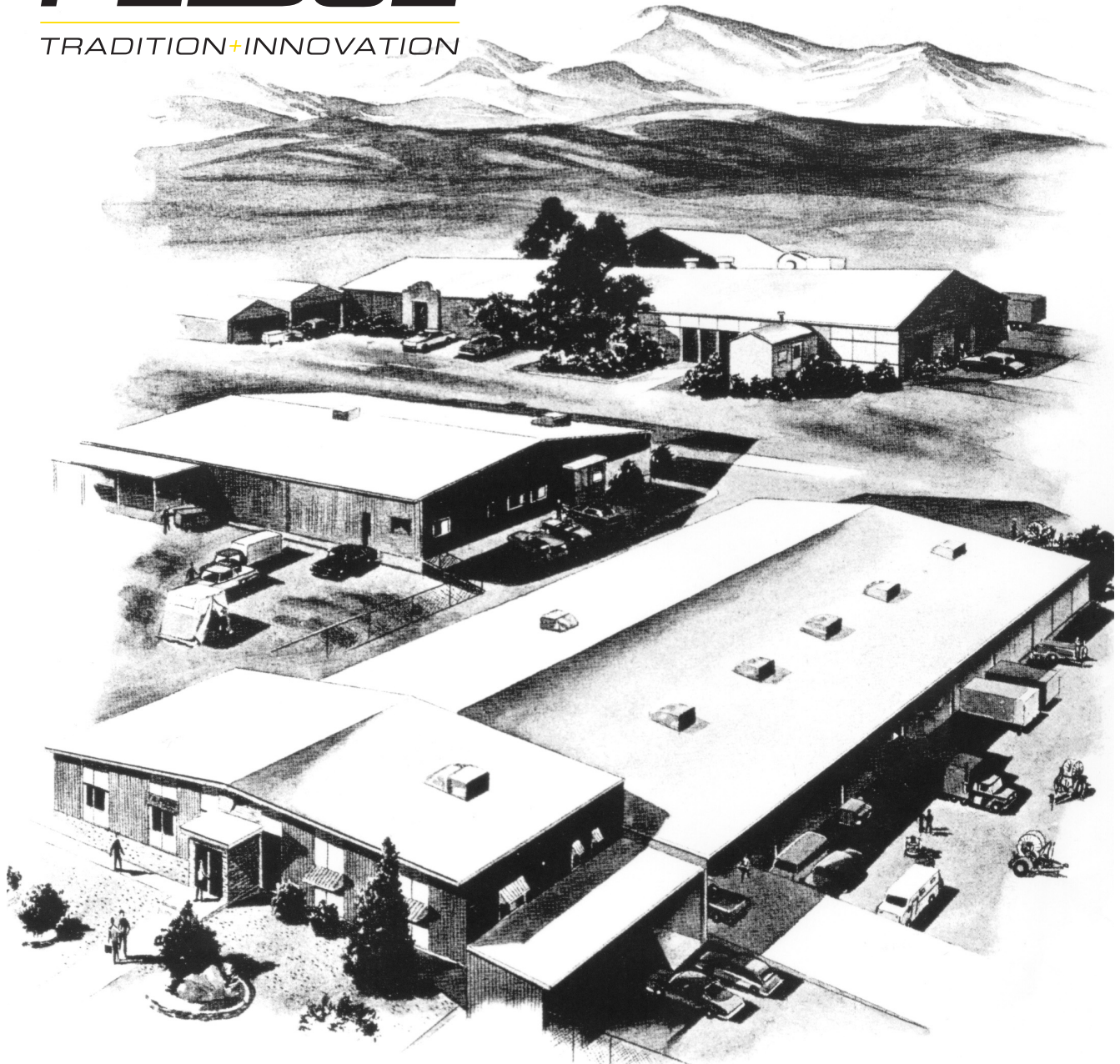

Since our inception in 1963 – the T.A. Pelsue Company has designed and manufactured high quality equipment to improve the personnel efficiency and working conditions in various underground, confined, and outdoor areas. Founded by T. Allen Pelsue, the company has established a continuing reputation for excellence in the production of fine products for a broad spectrum of industry throughout the world.

Now, in our second generation of family direction, continued commitment to innovation and quality makes Pelsue a leading source of equipment for many types of confined spaces. We specialize in safety, retrieval, fall arrest, ventilation, cable placing, splicing, and maintenance nationally and abroad. With more than 70,000 square feet of facilities available, Pelsue continues the dedication that has made us pre-eminent in this field.

Table of Contents

Section	Description	Page #
1.0	General Information	5
1.1	Quality Policy	
1.2	Pelsue Product Warranty	
2.0	Introduction & Product Information	7
2.1	Serial Number	
3.0	Configuration & Assembly	8
4.0	Safety	9
4.1	Warning Statement	
4.2	Safety Alert Symbol	
4.3	General Safety Information	
4.4	Operating Safety	
4.5	Maintenance Safety	
4.6	New Operator Safety Information	
5.0	Product Operation	12
5.1	Product Description & Capabilities	
5.2	Product Installation & Set-Up	
6.0	Maintenance & Inspection	16
6.1	Maintenance	
6.2	Inspection	
6.3	Inspection Log	
7.0	Storage	19
8.0	Contact Information	19

T.A. Pelsue Company

Quality Policy

OUR GOAL IS THE PURSUIT OF NEVER-ENDING IMPROVEMENT IN PRODUCT QUALITY AND BUSINESS SYSTEMS.

METHODS TO BE EMPLOYED IN ATTAINING THIS GOAL WILL INCLUDE NEW PRODUCT QUALITY PLANNING, EMPLOYEE TRAINING, AND UTILIZATION OF EMPLOYEE INVOLVEMENT GROUPS TO SOLVE PROBLEMS.

IN AN INCREASINGLY COMPETITIVE MARKETPLACE, ENSURING CUSTOMER SATISFACTION IS ONE OF THE DIFFERENTIATORS THAT SETS YOU APART FROM THE PACK AND YIELDS A COMPETITIVE ADVANTAGE.

THEREFORE, WE WILL SUPPORT TOTAL CUSTOMER SATISFACTION BY IMPLEMENTING THE **ISO 9001 QUALITY SYSTEM** AND PROVIDING THE NECESSARY ATMOSPHERE AND TRAINING TO NURTURE THIS CONCEPT THROUGHOUT OUR ORGANIZATION.

WE WILL MAKE EVERY BUSINESS DECISION AS THOUGH THE QUALITY OF THE PART OR SERVICE PROVIDED WAS DESTINED FOR OUR OWN OR OUR FAMILY'S USE. WE WILL ALWAYS THINK **QUALITY FIRST**.

EVERY T.A. PELSUE COMPANY EMPLOYEE IS EXPECTED TO COMMIT TO THIS PHILOSOPHY IN THE PERFORMANCE OF HIS OR HER DAILY TASKS.

QUALITY FIRST!

T.A. PELSUE COMPANY SENIOR MANAGEMENT TEAM

1.2 - Pelsue Product Warranty

Pelsue products are designed and engineered to perform as stated in published specifications. Quality materials and workmanship are used in the manufacture of this product. With regular maintenance and proper care, Pelsue equipment provides many trouble free hours of operation.

The T.A. Pelsue Company warrants to the buyer that the Hoist Product furnished will conform to specifications and will be free from defects in material and workmanship from the date of shipment to the original buyer, for a period of 3 months (90 days). In the event of failure of any components of a Pelsue product within the warranty period, service must be pre-approved by the T.A. Pelsue Company, and service must be performed by the T.A. Pelsue Parts and Service Department in Englewood, Colorado, or at the option of the T.A. Pelsue Company, service may be performed at any designated service center, which may include any authorized service center for the component manufacturer. Unauthorized repairs will not be covered by this warranty.

Damage or failure due to misuse, mishandling, or unauthorized modifications will not be covered by this warranty. Unless otherwise agreed, the T.A. Pelsue Company shall repair or replace the defective components within (30) calendar days of notice of failure. T.A. Pelsue Company's obligation hereunder, shall be limited to the repair or replacement of the product or component as set forth above and shall not include any liability whatsoever for damages caused by such failure, including, but not limited to consequential or incidental damages flowing from use or lack of use of product.

Any replacement, repair, modification, installation, or other service performed by the T.A. Pelsue Company shall be warranted by the remainder of the unexpired period of the warranty, or for a period of (90) calendar days, whichever is longer.

All materials or parts returned for credit or warranty shall be returned only with prior approval, and will be subject to factory inspection before credit is allowed. Parts claimed defective will be replaced upon request and will be invoiced as purchased, subject to credit when the parts claimed to be defective have been received and examined by the factory.

This warranty is expressly in lieu of all other warranties expressed or implied, including any warranties of merchantability or warranties of fitness for any particular use and all other obligations or liabilities in connection with the sale of this equipment.

T.A. Pelsue Company, 2500 South Tejon Street, Englewood, Colorado 80110, 800-525-8460

2.0 - Introduction & Product Information

Congratulations on your choice of a **Pelsue Model #BC-08A Adjustable Angle Beam Clamp** to compliment your fall arrest system. This equipment has been designed and manufactured to exceed fall arrest requirements and regulations in order to meet the needs of the discriminating operator.

Safe, efficient and trouble-free operation and maintenance of the system requires that anyone who will be operating, maintaining, or inspecting the equipment, read, understand and follow all of the operation, safety, maintenance, and inspection instructions contained within this manual. This manual covers the Pelsue Model #BC-08A Adjustable Angle Beam Clamp. Use the Table of Contents as a guide to find specific information.

Keep this manual available for future reference and for usage as a tool in the instruction of new operators. Establish a regular training program for all operators. Establish a regular maintenance and inspection program to keep the equipment in top condition.

⚠ WARNING

This product is a part of a complete Fall Arrest system. The user must read, understand and follow the instructions contained in this manual for each component or total system before using this equipment. Establish an appropriate training, maintenance and inspection program for your people and the equipment. Failure to follow these instructions could result in serious injury or death.

2.1 - Serial Number

Product Serial Number

Always give your dealer the serial number of your Pelsue Fall Arrest product when ordering parts or requesting service or other information.

The serial number decal is permanently embossed with a serial number. The serial number decal will appear as shown in *Figure 2a* at the right and is located on the side of the beam clamp (see *Figure 2b*). A space has been provided below for the recording of the serial number for future reference.

S/N#	_____
MODEL#	_____
DOM	_____

Figure 2a:
Serial Number Decal

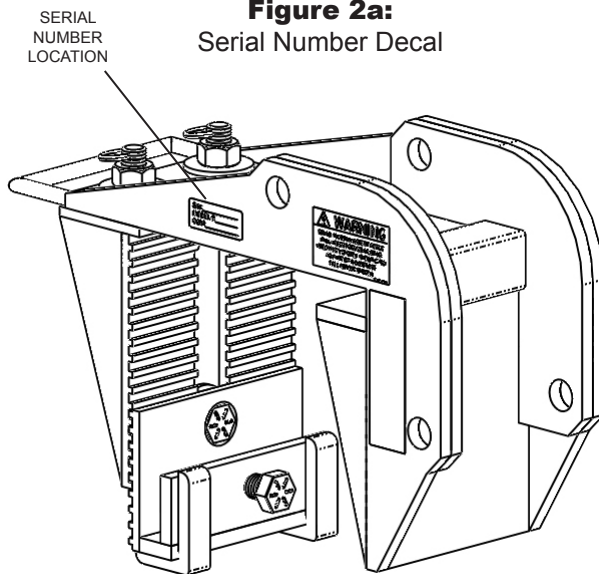

Figure 2b:
Serial Number Decal Location

MODEL: **#BC-08A** _____

Serial Number : _____

Date of Manufacture (DOM): _____

3.0 - Configuration & Assembly

Upon initial receipt of the #BC-08A system, inspect the packaging for any evidence that the product may have been damaged in shipment. While unpacking the product, inspect all of the components for damage. If damage to any of the components is discovered, DO NOT USE THE PRODUCT! Alert the shipping carrier immediately of the damage to the shipment.

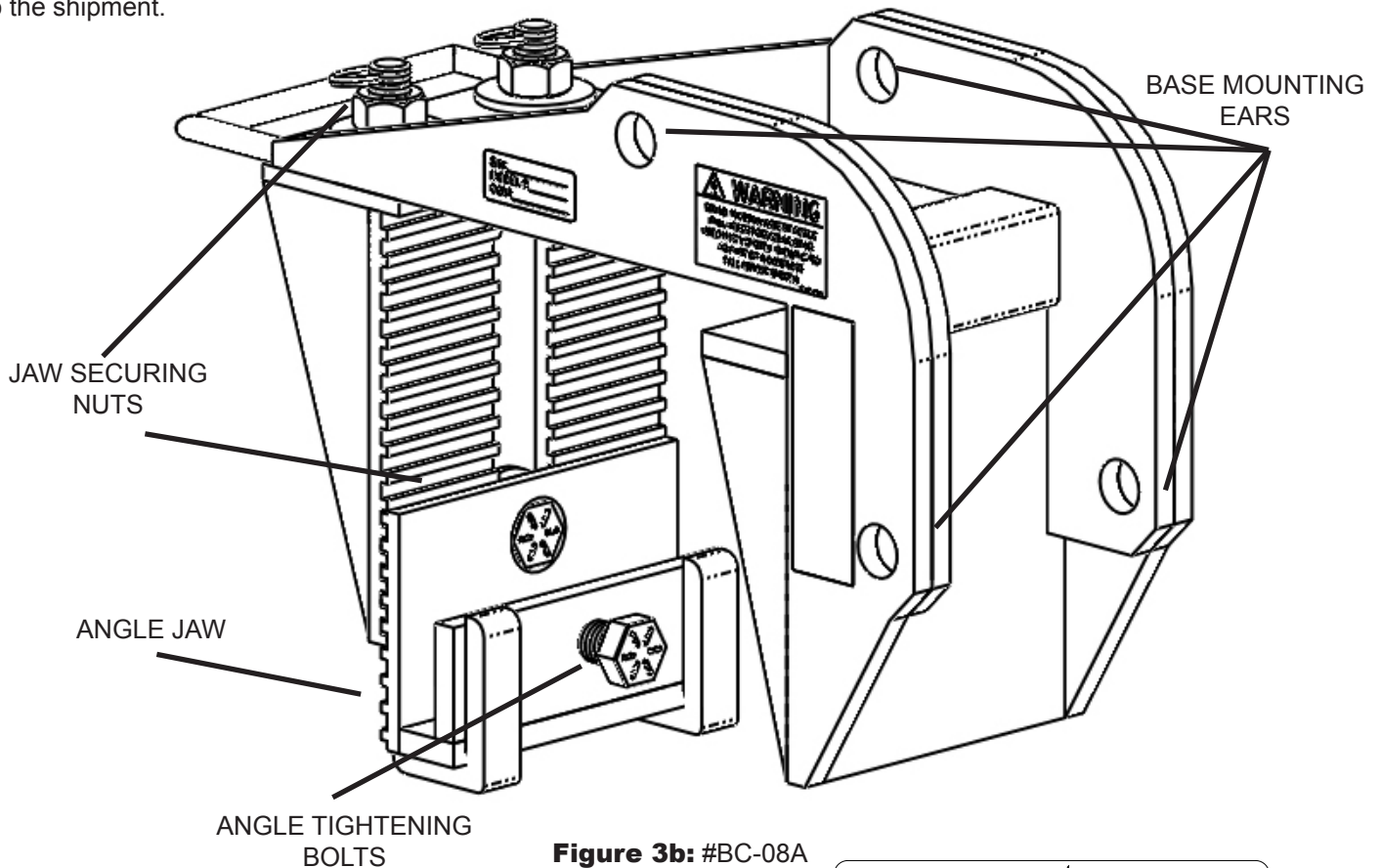

Figure 3b: #BC-08A
Parts Diagram

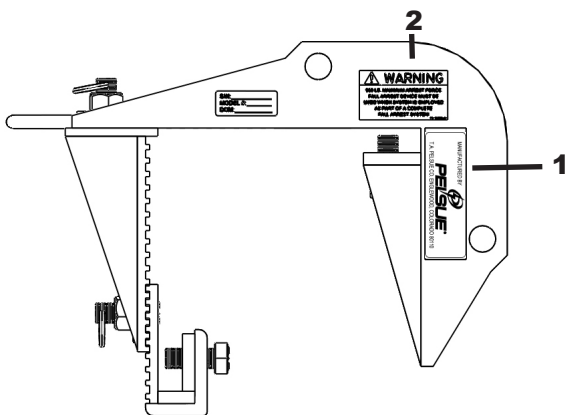

Figure 3c: #BC-08A
Label Location



1) 102072-002

WARNING

**900 LB. MAXIMUM ARREST FORCE
FALL ARREST DEVICE MUST BE
USED WHEN SYSTEM IS EMPLOYED
AS PART OF A COMPLETE
FALL ARREST SYSTEM**

P/N 500234-001

2) 500234-001

Verify that all parts are present before product use.
The #BC-08A is shipped fully assembled.

- 1.** Ensure that the product has been shipped with all the necessary components and is in working order (Refer to Fig. #3b)

**Refer to parts list above if replacement parts are required. Replacement parts can be ordered from the T.A. Pelsue Company at 800-525-8460.

The following section will address the safety precautions which must be adhered to when working with Pelsue Fall Arrest equipment such as the #BC-08A Adjustable Angle Beam Clamp. Any user must familiarize themselves with the information in this section before utilizing the equipment.

SIGNAL WORDS:

Note the use of the signal words **DANGER**, **WARNING** and **CAUTION** with the safety messages. The appropriate signal word for each message has been selected using the following guidelines:

- DANGER-** Indicates an imminently hazardous situation that, if not avoided, will result in death or serious injury. This signal word is to be limited to the most extreme situations or for hidden or unseen hazards.
- WARNING-** Indicates a potentially hazardous situation that, if not avoided, could result in death or serious injury and includes obvious and hidden hazards. It may also be used to alert against unsafe practices.
- CAUTION-** Indicates a potentially hazardous situation that, if not avoided, may result in minor or moderate injury. It may also be used to alert against unsafe practices.

You are responsible for the safe operation, maintenance and inspection of your Pelsue #BC-08A Adjustable Angle Beam Clamp. You must ensure that anyone who will operate, maintain, inspect or work around the equipment be familiar with the operating and maintenance procedures and related safety information contained in this manual. This manual will take you step-by-step through the workings and capabilities of the #BC-08A Adjustable Angle Beam Clamp and alert you to all good safety and operating practices while using the system.

Remember, you are the key to safety. Good safety practices not only protect you but also the people around you. Make these practices a working part of your safety program. Be certain that everyone operating this equipment is familiar with the procedures recommended and follows safety precautions. Remember, most accidents can be prevented. Do not risk injury or death by ignoring good safety practices.

- System owners must give operating instructions to operators or employees before allowing them to use the equipment and at least annually thereafter.
- The most important safety device on this equipment is a safe operator. It is the operator's responsibility to read and understand all safety and operating instructions in the manual and to follow those guidelines. Most accidents can be avoided.
- A person must understand the operation of this equipment and be trained in its usage before operating the equipment. An untrained operator exposes himself and others to possible serious injury or death.
- Do not modify the equipment in any way. Unauthorized modification may impair the function and/or safety and could affect the life of the equipment.
- Think SAFETY! Work SAFELY!

4.1 - Warning Statement

WARNING!

Products manufactured or sold by the T.A. Pelsue Company are intended for use by professionals trained and experienced in the use, inspection and maintenance of these products.

Paraprofessional users such as volunteer rescue workers and sportsmen involved in risk sports such as climbing and caving will be held to the same standard of experience and training as professionals.

Technical rescue, repelling, climbing and the training involved are hazardous activities. Each situation has its own unique conditions and must be evaluated. Effective risk management comes from experience, proper training and good personal judgement.



4.2 - Safety Alert Symbol

SAFETY ALERT SYMBOL

This Safety Alert symbol means **ATTENTION! BECOME ALERT! YOUR SAFETY IS INVOLVED!**

The Safety Alert symbol identifies important safety messages on your Pelsue Retrieval Product and in the manual. When you see this symbol, be alert to the possibility of personal injury or death. Follow the instruction in the safety message.



Why is this symbol important to you?

3 BIG Reasons: Accidents Disable and Kill.

Accidents Cost You Money.

Accidents Can Be Avoided.

4.3 - General Safety Information

1. Read, understand, and follow the Product Manual and all safety signs before using, maintaining or inspecting the equipment.
2. Refer to and follow applicable standards and regulations. Comply with requirements of local regulations for your applications.
3. Establish an equipment-use training program for inexperienced employees. Only trained, competent persons shall use the equipment. An untrained operator is not qualified to operate the system.
4. Have a first-aid kit available for use should the need arise and know how to use it.
5. Provide a fire extinguisher for use in case of an accident. Store in a highly visible place.
6. Install and properly secure all guards and shields before operating.
7. Wear appropriate protective gear. This list includes but is not limited to:
 - A hard hat
 - Protective shoes with slip resistant soles
 - Heavy gloves
 - Protective clothing
 - Face Protection
8. Review and follow the Pre-Operation Checklist before using a component in the system or system itself.
9. Establish a regular maintenance and inspection program with your equipment and maintain detailed records.
10. Review safety related items and operating instructions with all personnel on a regular basis.

4.4 - Operating Safety

1. Read, understand and follow the Product Manual as well as all printed warnings that may be located on the product itself before using, maintaining or inspecting the equipment.
2. Train all operators before allowing them to use the product. An untrained operator exposes themselves, bystanders and workers to possible serious injury or death.
3. Visually inspect the product and all auxiliary components and equipment before using. Correct any problems before using the equipment.
4. Securely anchor the product before using.
5. Use only certified anchor and connector components in your system.
6. Use only an approved full body harness for the workers.

4.4 - Operating Safety (continued)

- 7.** Always work in teams. When working upon an elevated surface where a fall is possible, making a subsequent rescue necessary, personnel must be available and ready for rescue immediately. Working alone with this equipment is inherently dangerous and not advised!
- 8.** Do not exceed the capacity of the system at any time (see section 5.1).
- 9.** Establish a regular training program for all operators and potential rescuers.
- 10.** Establish a detailed inspection program for your equipment and document the findings. Return the equipment to the manufacturer for repair if any problems are found.
- 11.** Plan your work program before starting. Have the required people, equipment and procedures readily available in order to safely complete any task prior to commencing.
- 12.** Do not use the equipment around physical or environmental hazards. This list includes but is not limited to:
 - Corrosion that may affect the structural integrity of the lifeline or other components.
 - Chemicals which can degrade components in a manner which can not be visually identified.
 - Toxic gases: Rescuers or workers can be killed in toxic environments.
 - Heat or elevated temperatures.
 - Moving machinery: Workers or auxiliary equipment can be contacted by or pulled into moving components.
 - Sharp edges: Workers or the rescue equipment can be injured by or damaged by sharp edges or components.
 - Electrical hazards: Stay away from power lines or components carrying electrical power.
 - Overload: Do not overload the system at any time during operation (see section 5.1).
 - Follow elevated space regulations and standards.

4.5 - Maintenance Safety

- 1.** Read, understand and follow the Product Manual as well as any printed warnings that may be present on the product before using, maintaining or inspecting the equipment.
- 2.** ANSI and OSHA require a regular inspection program for all fall arrest equipment as well as properly-documented results of the inspections. Follow the inspection procedures contained in this manual and use the inspection form to document the results (see section 6.0).
- 3.** Keep instructional and safety signs clean and legible at all times. Clean or replace as required.
- 4.** Remove the equipment from service if a problem is found during the inspection. Return to an authorized repair depot or the factory for service.

4.6 - New Operator or Owner

The Pelsue #BC-08A Adjustable Angle Beam Clamp is designed as a portable Base System for a Pelsue Model #FT-C70 fall arrest tower. Every new operator must read, understand and follow the instructions in this Product Manual. No person should be permitted to use the equipment without prior proper training. The training should be reviewed with experienced operators on a regular basis. At regular intervals, perform a detailed inspection of the equipment and document the results. Remove the product from service if any deficiencies are found. Alterations or misuse of this equipment or failure to follow instructions may result in serious injury or death.

It is the responsibility of the owner's organization to ensure that the proper training is provided to all operators of any fall arrest device before they start working with the equipment. Follow all safety instructions exactly. Safety is everyone's business. By following recommended procedures, a safe working environment is provided for the operator, bystanders and the area around the work site. Untrained operators are not qualified to operate the equipment.

Many features incorporated into this equipment are the result of suggestions made by customers like you. Read this manual carefully to learn how to operate & install the equipment safely and as intended. By following the operating instructions in conjunction with a good maintenance program, your product will provide many years of trouble free service.

5.0 - Product Operation

The following section will address the capabilities and the general operation of the Pelsue #BC-08A Adjustable Angle Beam Clamp. The instructions contained within this section should be adhered to each and every time the product is used. Any person tasked with installing or operating the piece of equipment should be familiar with these procedures.

5.1 - Product Description & Capabilities

The Pelsue #BC-08A Adjustable Angle Beam Clamp is built from carbon steel & incorporates high-strength alloy steel hardware. The BC-08A Adjustable Angle Beam Clamp is specifically designed to provide a compliant mounting point for a Pelsue Model #FT-C70 Fall Arrest Tower. All specifications, instructions, and procedures provided within this manual or upon Pelsue Specification Documents are based upon and only valid for usage with a Pelsue #FT-C70 Fall Arrest Tower. The T.A. Pelsue Company can not verify equipment safety and/or compliance when utilized with anything other than Pelsue- approved BC-08A complementary products.

General Specifications:

Designed for clamping attachment on structural steel angle beams commonly found in industrial locations

- Minimum Angle Beam: 3-1/2" x 3-1/2"
- Maximum Angle Beam: 8" x 8"
- Product Weight: 35 lbs.

Compliance & Rating:

- **Fall Arrest Tower Mounting:** The #BC-08A Base Lugs provide a compliant mounting point for a Pelsue Model #FT-C70 Fall Arrest Tower when the tower is installed and utilized per the published requirements.

Other Requirements:

- It is the user's responsibility to ensure that the structure to which the #BC-08A is attached is capable of withstanding the loads imparted to it by a proof-loaded system in order to retain stated compliance. *Refer to the loading diagrams located within this section for required information*
- The #BC-08A is only to be used in conjunction with a Peluse Model #FT-C70 Fall Arrest Tower, the system must be employed according to the requirements and limitations of both the angle beam clamp and the fall arrest tower.

Materials & Construction

- Main Structure - Carbon Steel
- Hardware - Grade 8 Plated Steel

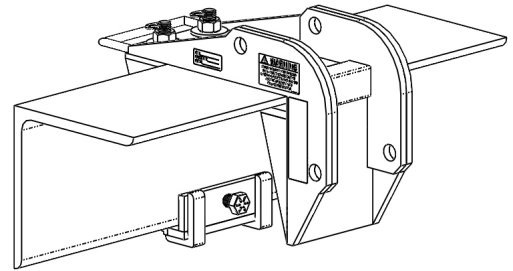

Figure #5.1a: #BC-08A Installed on Angle Beam: Top Configuration

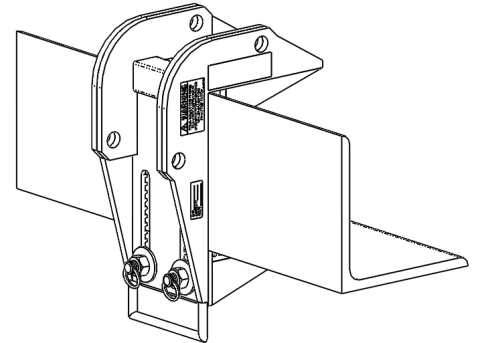

Figure #5.1b: #BC-08A Installed on Angle Beam: Edge Configuration



The load ratings presented here may supersede or be superseded by the capabilities of an installed accessory. The rating of a complete fall arrest system can only be rated to the capabilities of its lowest-rated component.



! WARNING ! - The user must ensure that the beam to which the #BC-08A is attached is capable of withstanding all of the loads imparted to it by the device when proof-loaded. There is a limitless variety of structural steel configurations and addressing each potential scenario is beyond the scope of this manual. A "qualified person" must approve each attachment point.

! WARNING ! - The user must ensure that all fasteners are properly secured in order to retain the stated compliance of the entire system.

5.1 - Product Description & Capabilities (continued)

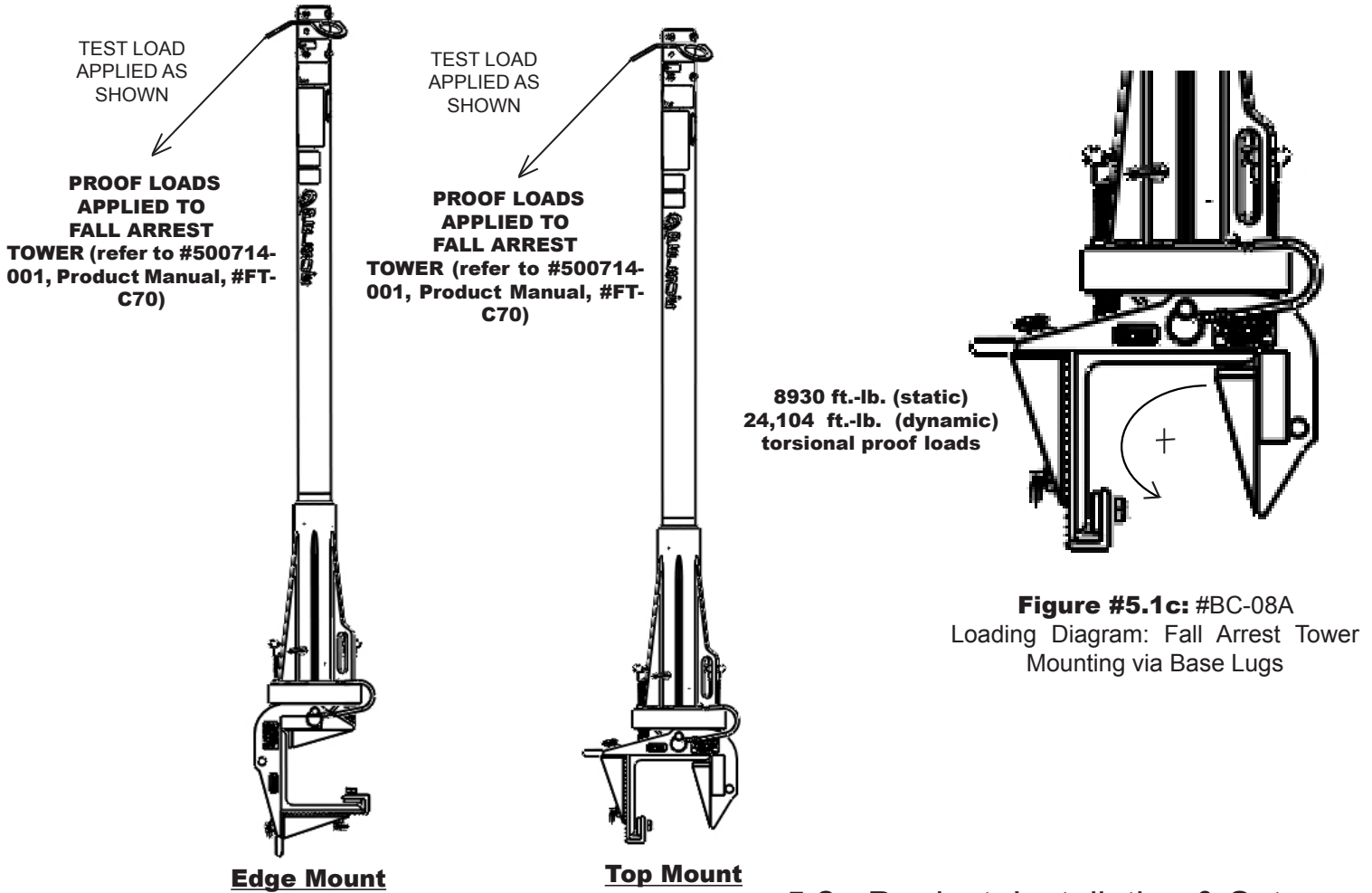

5.2 - Product Installation & Set-up

Prior to Operation, the #BC-08A Adjustable Angle Beam Clamp must be configured and installed according to the following guidelines.

1. Pre-Operation Inspection:

It is necessary to perform a visual inspection prior to each time using the product. If any deficiencies are found, remove the product from service and contact the T.A. Pelsue Co. regarding repair. The following checklist coupled with *Figure #5.2a* should be used as a guide to determine whether the equipment is in good operating condition prior to usage. Equipment that is not in good condition can endanger the safety of the operators during use.

The Pre-Operation Visual Inspection is not limited to, but must include the following items;

- a. Check that the product has no structural defects, such as dents, bends, cracks, or fractures.
- b. Ensure that all product rating & warning labels are clear and legible.
- c. Check that the track teeth mesh properly when tightening down on the tightening nuts. (improper meshing can be indicative of a defect).
- d. All hardware has not been damaged and is in working condition.

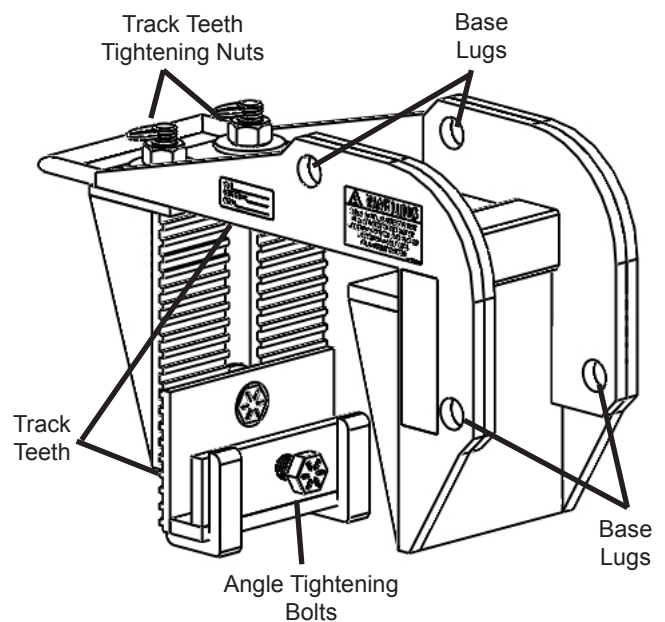

Figure #5.2a: #BC-08A
Pre-Operation Inspection Points

5.2 - Product Installation & Set-up (continued)

2. Installation of the #BC-08A Adjustable Angle Beam Clamp:

Choose a location where installation will provide suitable proximity to the work area yet minimize obstructions during use and in the event a rescue is necessary.

•When utilized as a Fall Arrest Tower Anchorage: Install The clamp so that the tower to be utilized will clear all obstructions yet provide full access to all required work areas within the towers's safe working radius.

****Once a location is chosen, Ensure that the structure to which the clamp will be attached is capable of withstanding all of the forces imparted to it by the proof-loaded system (Refer to Section 5.1 of this manual).**

- Loosen all nuts on the clamp so that the sliding pieces are able to move freely. The beam clamp can now be placed around the desired installation angle (Refer to Fig. #5.2b).
- Position the clamp so that the fixed slot of the beam clamp comes in contact with the angle first (Refer to Fig. #5.2c).
- Simultaneously slide the vertical & "J" shaped plates so that they come into contact around the rest of the angle beam (Refer to Fig. #5.2d).
- Ensure that the beam's face is in contact with all the contact surfaces of the clamp. (Refer to Fig. #5.2d).
- Tighten the nuts ensuring that the track teeth of both movable plates mesh properly (Refer to Fig. #5.2d).

! WARNING ! - the clamp must not be utilized if the track teeth are not properly meshed!

- Check to see and ensure that there is not any excess gap between the clamp jaws and the angle beam (Refer to Fig. #5.2e).

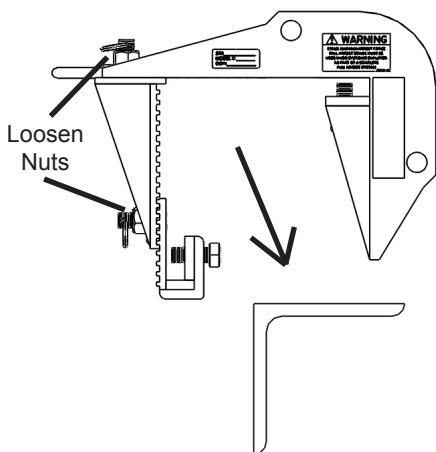

Figure #5.2b: #BC-08A
Pre - Installation

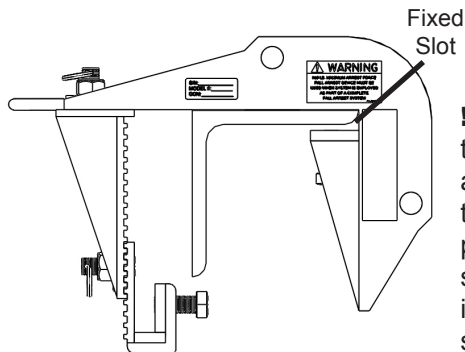

Figure #5.2c: #BC-08A
Installation



! WARNING ! - The user must ensure that the beam to which the #BC-08A is attached is capable of withstanding all of the loads imparted to it by the device when proof-loaded. There is a limitless variety of structural steel configurations and addressing each potential scenario is beyond the scope of this manual. A "qualified person" must approve each attachment point.

!WARNING! - The user must ensure that the #BC-08A is properly installed & securely clamped on the selected structure before attaching any lifeline or additional fall arrest system components.

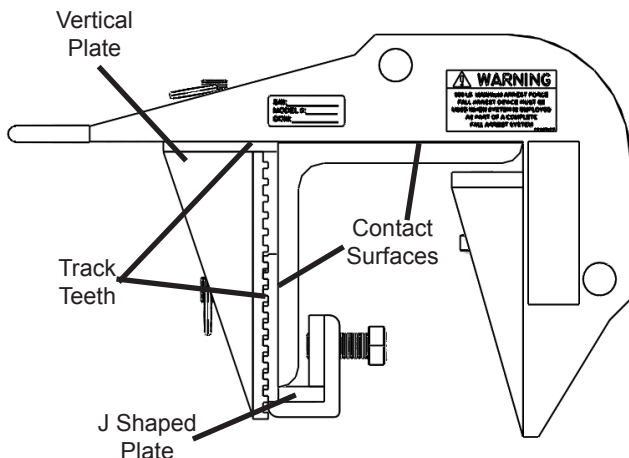

Figure #5.2d: #BC-08A
Installation

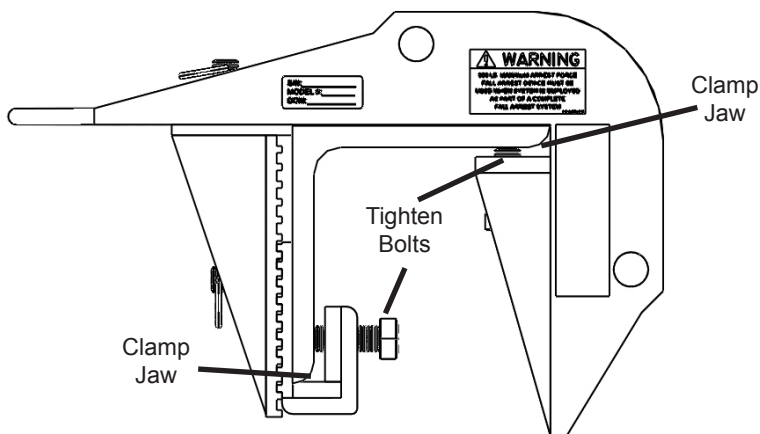

Figure #5.2e: #BC-08A
Completely Installed

3. Installation of a #FT-C70 Fall Arrest Tower on the #BC-08A Angle Beam Clamp

- a. Install the #BC-08A Angle Beam Clamp per the instructions in Step #2 of section 5.2 of this manual.
- b. After the #BC-08A has been completely installed, remove the pin from the base of the fall arrest tower.
- c. Place the fall arrest tower onto the #BC-08A, center the base of the tower between the base lugs present on the angle beam clamp (Refer to Fig. 5.2f).
- d. Align the holes of the fall arrest tower base with the holes of the base lugs on the #BC-08A and replace the tower's retaining pin (Refer to Fig. 5.2g).
- e. Adjust the levelling pegs in order to make the tower vertical (Refer to Fig. 5.2g). **! WARNING !** - The #FT-C70 fall arrest tower can only be used for the anchoring of personal fall arrest systems when placed in a vertical position!
- f. Utilize the installed fall arrest tower within the limits of and according to the instructions provided within the Model #FT-C70 fall arrest tower's product manual.

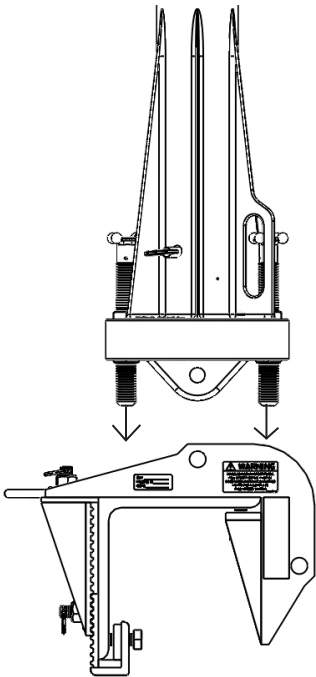

Figure #5.2f: #BC-08A & FT-C70 Installation

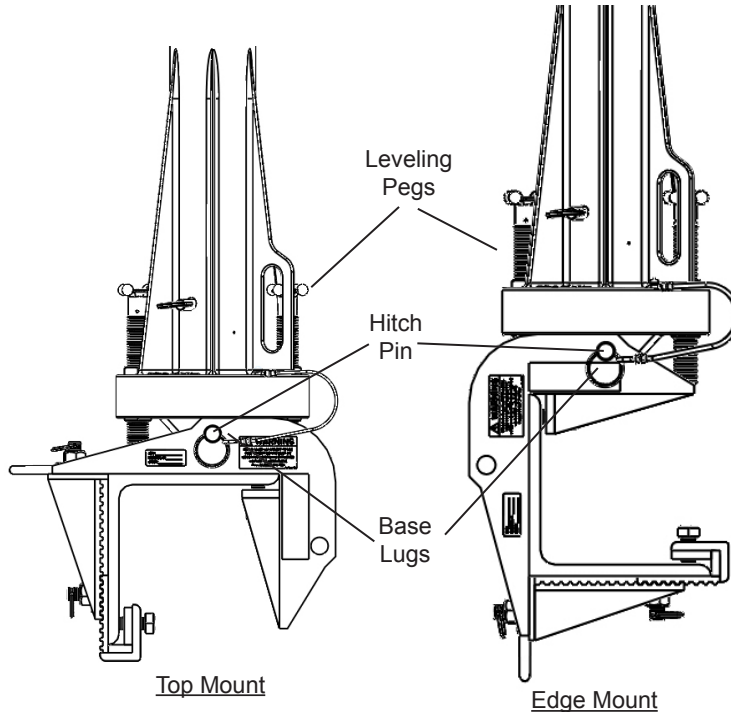

Figure #5.2g: #BC-08A & FT-C70 Installation

!WARNING! - The orientations shown above are the only two approved configurations in which the FT-C70 Fall Arrest Tower can be installed and utilized.



!WARNING! - The FT-C70 Fall Arrest Tower utilized in conjunction with the #BC-08A Angle Beam Clamp must be installed according to its product manual, and utilized by a qualified individual in order to retain its stated rating & compliance.

!WARNING! - Any FT-C70 Fall Arrest Tower Attached to the #BC-08A Angle Beam Clamp must be utilized within its published limits and capabilities. The rating of the installed tower may supersede or derate the capabilities of the #BC-08A beam clamp.

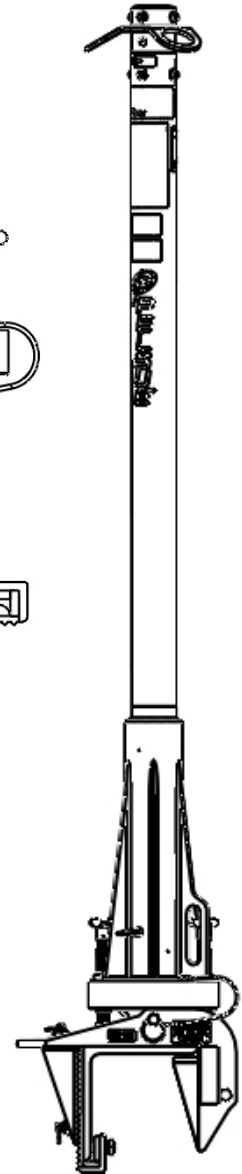

Figure #5.2h: #BC-08A & FT-C70 Completely Installed

6.0 - Maintenance & Inspection



MAINTENANCE & INSPECTION

1. Read, understand and follow the Product Manual and signs on the product before using, maintaining or inspecting the equipment.
2. ANSI and OSHA require a regular inspection program for all fall arrest equipment and to maintain documented results of these inspections. Follow the inspection procedure contained in this manual and use the inspection form to document the results.
3. Keep instructional and safety signs clean and legible at all times. Clean or replace as required.
4. Remove the equipment from service if a problem is found during the inspection. Return to an authorized repair depot or the factory for service.

6.1 - Maintenance

For the most part, the Model #BC-08A is intended to be a maintenance-free piece of equipment, however several steps can be taken to keep the system in top-notch working order and also extend the working life of the product.

Before Each Use:

1. Visual Inspection: Perform a complete visual inspection. Refer to section 6.2 for guidelines and take any maintenance steps that are necessary.

Annually:

1. Clean Product: Use a damp cloth and mild soap to clean the structure and labels of dirt and residue. Be sure the labels are legible (replacements are available from Pelsue)
2. Lubricate all Fastener Threads: Apply a water resistant lubricant suitable for high-strength steel fasteners to all threads in order to extend the working life of these components.
3. Complete Inspection: Perform a thorough inspection, paying attention to the bullet points provided within section 6.2. Record results and keep documentation. A log has been provided in section 6.3 specifically for the recording of the dates & results of annual system inspections.

Periodic Factory Service Inspection: It is recommended that the product be serviced by a factory authorized service center or the manufacturer after a period of three years. Extreme working conditions may make it necessary to increase the frequency of such and evaluation. Factory servicing shall include but not be limited to an intensive inspection and cleaning of all internal and external components. Failure to provide proper service may shorten product life and could endanger performance or function.

6.2 - Inspection

When completing an inspection of the Model #BC-08A Adjustable Angle Beam Clamp, the following specific items should be checked;

1. Labels:

Check that all of the labels are clean and legible (Refer to Section 3.0). Clean the labels if any are dirty using mild soap and a damp cloth. Replace if any are illegible. Decals & labels provide valuable warning and caution information applicable to product usage and limitations, and should be visible and present at all times.

2. Base Lugs:

Visually inspect for any fracture or deformation. Overloading of the system can and will deform and damage the lugs. Any Model #BC-08A system exhibiting deformation should be removed from service immediately.

3. Structure:

The entire product structure should be checked for cracks, gouges, dents, bends or breaks. If there are dents or

any other structural damage, the unit should be removed from service and returned to the factory for repair.

- Pay special attention to weld locations: look for cracks or separation at the welds. Keep in mind the nickel plating can age and scratch, this normal finish scratching can be confused with structural cracking. If there is any uncertainty with regards to cracks, contact the Pelsue service department for assistance and/or recommendations
- Ensure that the sections of the device can freely move and be adjusted as intended without interference. Binding or interference of any kind may be indicative of structural damage and must be cause for further inspection.

4. Track Teeth:

Ensure that when the tightening nuts are loosened, that the plates equipped with track teeth can be easily extended or retracted without any binding. Any binding could be indicative of damage to the plates. Ensure that the track teeth can mesh properly when the tightening nuts are secured. If required, the rings that prevent the tightening nuts from becoming un-threaded from the bolts can be removed so that the nuts can be completely un-threaded. Doing so will make it possible to disassemble the plates so that they can be thoroughly cleaned. Clean or wipe away and dirt or debris that could cause improper meshing of the track teeth.

6.3 - Inspection Log

#BC-08A

Model Number :

Serial Number :

Date Purchased :

Place a check (✓) in the box if item is acceptable, place an x (X) in the box if item requires maintenance or repair

Date	Labels	Base Lugs	Structure	Track Teeth	Notes
Inspector (print & sign) :					
Inspector (print & sign) :					
Inspector (print & sign) :					
Inspector (print & sign) :					
Inspector (print & sign) :					

7.0 - Storage

Prior to storage, the product should be thoroughly inspected and maintained. Repair or replace any worn or damaged components to prevent any unnecessary down time at the next use.

Follow this procedure:

1. Thoroughly clean the entire unit using a mild soap on the frame and labels.
2. Perform a complete inspection of the unit and document the results prior to storage.
3. Ensure that the unit is completely dry prior to storage.

8.0 - Contact Information

For More Information...



T.A. Pelsue Company
2500 S. Tejon St.
Englewood, CO 80110

Toll Free: 1-800-525-8460
Telephone: 1-303-936-7432
Fax: 1-303-934-5581

Website: www.pelsue.com

Email: sales@pelsue.com



T.A. Pelsue Company

2500 South Tejon Street, Englewood, Colorado, USA 80110
Toll free 800-525-8460 or 303-936-7432 Fax. 303-934-5581
Internet: www.pelsue.com Email: sales@pelsue.com