

Part #120944-001

Product Manual:

Model #1690D
In-Line Heater



PELSUE[®]
ISO 9001 Certified

T.A. Pelsue Company
2500 South Tejon Street
Englewood, Colorado, USA 80110
Tel. 800-525-8460 or 303-936-7432
Fax. 303-934-5581
Internet: www.pelsue.com
Email: sales@pelsue.com

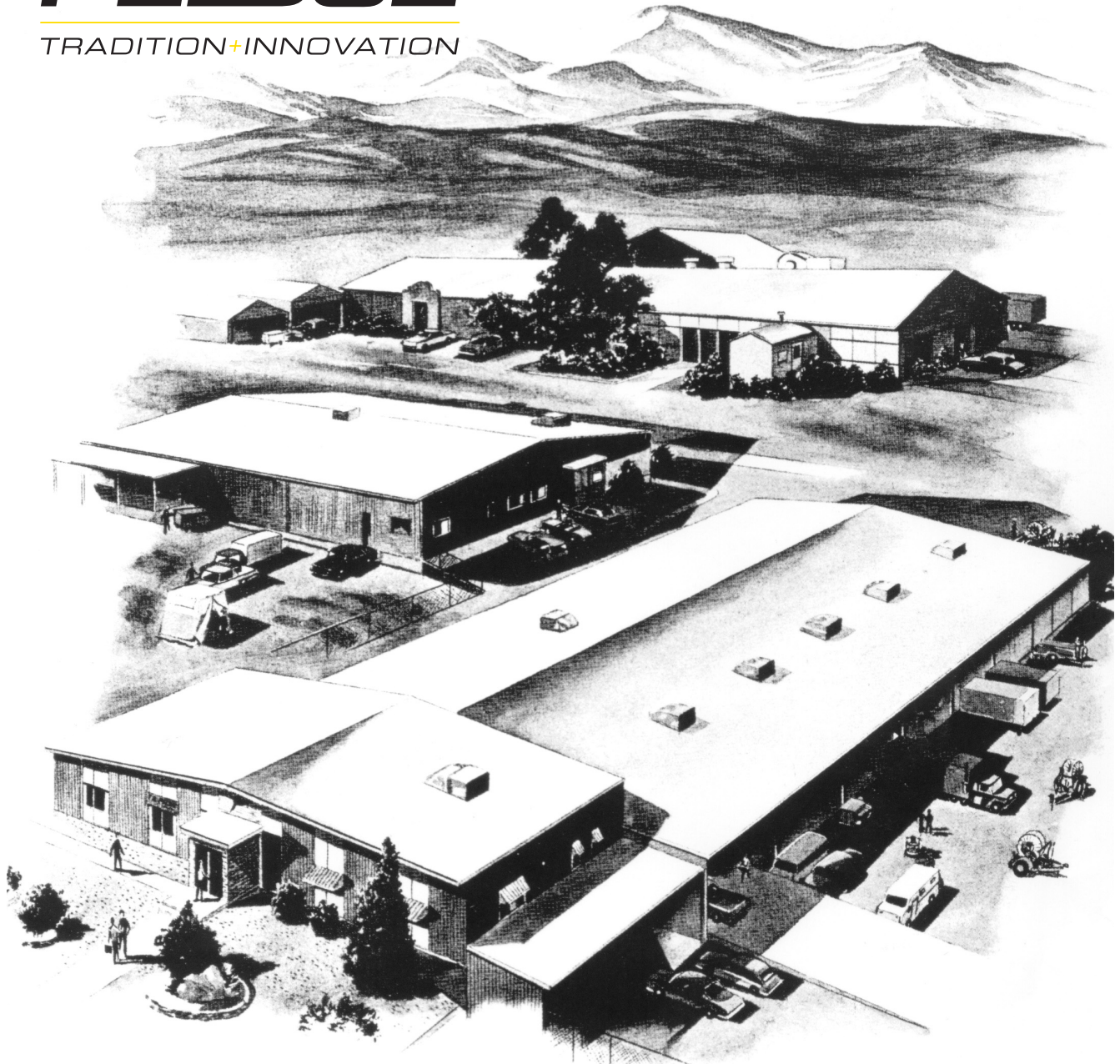

Since our inception in 1963 – the T.A. Pelsue Company has designed and manufactured high quality equipment to improve the personnel efficiency and working conditions in various underground, confined, and outdoor areas.

Founded by T. Allen Pelsue, the company has established a continuing reputation for excellence in the production of fine products for a broad spectrum of industry throughout the world.

Now, in our second generation of family direction, continued commitment to innovation and quality makes Pelsue a leading source of equipment for many types of confined spaces. We specialize in safety, retrieval, fall arrest, ventilation, cable placing, splicing, and maintenance nationally and abroad. With more than 70,000 square feet of facilities available, Pelsue continues the dedication that has made us pre-eminent in this field.

Table of Contents

Section	Description	Page #
1.0	General Information	5
1.1	Quality Policy	
1.2	Pelsue Product Warranty	
2.0	Introduction & Product Information	7
2.1	Serial Number	
3.0	Configuration & Assembly	8
3.1	Parts Diagram & List	
3.2	Wiring Diagram	
4.0	Safety	12
4.1	Safety Alert Symbol	
4.2	General Safety Information	
5.0	Product Operation	14
5.1	Product Description & Capabilities	
5.2	Start-Up & Operating Procedures	

T.A. Pelsue Company

Quality Policy

OUR GOAL IS THE PURSUIT OF NEVER-ENDING IMPROVEMENT IN PRODUCT QUALITY AND BUSINESS SYSTEMS.

METHODS TO BE EMPLOYED IN ATTAINING THIS GOAL WILL INCLUDE NEW PRODUCT QUALITY PLANNING, EMPLOYEE TRAINING, AND UTILIZATION OF EMPLOYEE INVOLVEMENT GROUPS TO SOLVE PROBLEMS.

IN AN INCREASINGLY COMPETITIVE MARKETPLACE, ENSURING CUSTOMER SATISFACTION IS ONE OF THE DIFFERENTIATORS THAT SETS YOU APART FROM THE PACK AND YIELDS A COMPETITIVE ADVANTAGE.

THEREFORE, WE WILL SUPPORT TOTAL CUSTOMER SATISFACTION BY IMPLEMENTING THE **ISO 9001 QUALITY SYSTEM** AND PROVIDING THE NECESSARY ATMOSPHERE AND TRAINING TO NURTURE THIS CONCEPT THROUGHOUT OUR ORGANIZATION.

WE WILL MAKE EVERY BUSINESS DECISION AS THOUGH THE QUALITY OF THE PART OR SERVICE PROVIDED WAS DESTINED FOR OUR OWN OR OUR FAMILY'S USE. WE WILL ALWAYS THINK **QUALITY FIRST**.

EVERY T.A. PELSUE COMPANY EMPLOYEE IS EXPECTED TO COMMIT TO THIS PHILOSOPHY IN THE PERFORMANCE OF HIS OR HER DAILY TASKS.

QUALITY FIRST!

T.A. PELSUE COMPANY SENIOR MANAGEMENT TEAM

1.2 - Pelsue Product Warranty

PELSUE PORTABLE PRODUCT WARRANTY

- Pelsue products are designed and engineered to perform as stated in published specifications. Quality materials and workmanship are used in the manufacture of this product. With regular maintenance and proper care, Pelsue equipment provides many trouble free hours of operation.
- The T.A. Pelsue Company warrants to the buyer that material furnished will conform to specifications and will be free from defects in material and workmanship from the date of shipment to the original buyer, for the period listed by product description on the reverse side of this warranty statement.
- In the event of failure of any components of a Pelsue product within the warranty period, service must be pre-approved by the T.A. Pelsue Company and service must be performed by the T.A. Pelsue Company Parts and Service Department in Englewood Colorado, or at the option of T.A. Pelsue Company, service may be performed at any designated service center, which may include any authorized service center for the component manufacture.
- Damage or failure due to misuse, mishandling, or unauthorized modifications will not be covered by this warranty. Unless otherwise agreed, the T.A. Pelsue Company shall repair or replace the defective components within (30) calendar days of notice of failure. T.A. Pelsue Company's obligation hereunder, shall be limited to the repair or replacement of the product or component as set forth above, and shall not include any liability whatsoever for damages caused by such failure, including but not limited to consequential or incidental damages flowing from use or lack of use of product.
- Any replacement, repair, modification, installation or other service performed by the T.A. Pelsue Company shall be warranted by the remainder of the unexpired period of the warranty, or for a period of (90) calendar days, whichever is longer.
- All materials or parts returned for credit or warranty shall be returned only with prior approval, and will be subject to factory inspection before credit is allowed. Parts claimed defective will be replaced upon request and will be invoiced as purchased, subject to credit when the parts claimed to be defective have been received and examined by the factory.
- This warranty is expressly in lieu of all other warranties expressed or implied, including any warranties of merchantability or warranties of fitness for any particular use and all other obligations or liabilities in connection with the sale of this equipment.

<u>Product Description</u>	<u>Warranty Coverage*</u>
• Ventilators	1 year
• Heaters	1 year
• Ventilator Hoses/Ducts	3 months
• Pel-Cans and Caddys	1 year
• Hose Adapters	1 year
• Manhole Shields & Manhole Guards.....	1 year
• Pel-Brite Work Lights	6 months
• Planks and Plank Supports	6 months
• Duct Rodders and Accessories.....	6 months
• Submersible Pumps.....	6 months
• Discharge and Suction Hoses for Pumps.....	3 months
• Wheel Chocks.....	1 year

*From date of shipment to original buyer.

T.A. Pelsue Company, 2500 South Tejon Street, Englewood, Colorado 80110, 800-525-8460

2.0 - Introduction & Product Information

Congratulations on your choice of a **Pelsue Model #1690D In-Line Heater** to compliment your confined space heating and ventilation operation. This equipment has been designed and manufactured to exceed confined space requirements and regulations in order to meet the needs of the discriminating operator for the efficient and safe operations of personnel in a confined space.

Safe, efficient and trouble-free operation and maintenance of the system requires that anyone who will be operating, maintaining, or inspecting the equipment, read, understand and follow all the operation, safety, maintenance, and inspection instructions contained within this manual. This manual covers the Pelsue Model #1690D In-Line Heater. Use the Table of Contents as a guide to find specific information.

Keep this manual handy for frequent reference and to pass on to new operators.

WARNING

This product is a part of a system for confined space ventilation operations. The user must read, understand and follow the instructions contained in this manual before using this equipment. Failure to follow these instructions could result in serious injury or death.

2.1 - Serial Number

Product Serial Number

Always give your dealer the serial number of your Pelsue In-Line Heater product when ordering parts or requesting service or other information.

The specification & rating decal is permanently embossed with a serial number. The rating decal is located on the front of the control box housing cover, as shown in *Fig. 2a*. The specification & rating decal will appear as shown to the right in *Fig. 2b*. A space has been provided below for the recording of the serial number for future reference.

MODEL: **#1690D**

Serial Number : _____

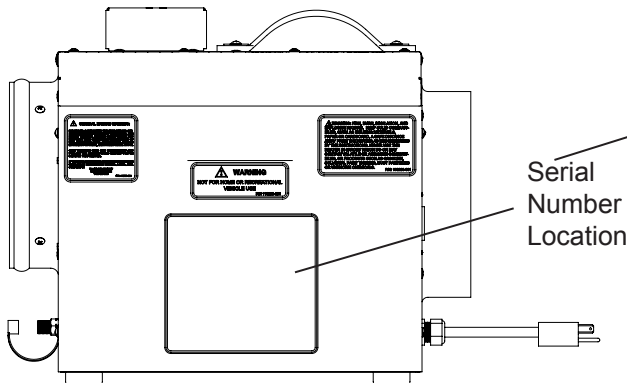

Figure 2a: Serial Number Location

**MODEL #1690D:
INLINE HEATER**

120 VAC, 60 HZ, 3.5 AMP

SERIAL No. 1690D-1-

2500 South Tejon Street
Englewood, Colorado 80110

INPUT (BTUH)	CERTIFIED AIR DELIVERY			MIN. CLEARANCE TO COMBUSTIBLES & FUEL	
70,000	FREE AIR	1X) 90° BEND	2X) 90° BENDS	TOP:	18"
	639 CFM	532 CFM	488 CFM	SIDES:	24"
	18.1 cu./min.	15.1 cu./min.	14.1 cu./min.	HEATER OUTLET:	80"
			HOSE END:		24"

GAS PRESSURE, FOR USE WITH PROPANE GAS ONLY			
ORIFICE SIZE FOR INSTALLATION AT SPECIFIED ALTITUDE	MANIFOLD PRESSURE	MINIMUM INLET TO REGULATOR PROVIDED FOR PURPOSES OF INPUT ADJUSTMENT	MAXIMUM INLET TO REGULATOR PROVIDED
0-4500'	5X) #56	10.5" W.C.	15 PSI
			50 PSI

! WARNING

This equipment is for outdoor use only and for operation in ambient temperatures down to -40°F (-40°C). To avoid serious injury, death, and property damage, read the safety warnings and instructions included in the product manual included with this heater. This heater is designed for use in industrial / utility applications only. Installation must be in accordance with local codes for propane equipment. This equipment is not for residential use or for use with mobile homes, RV's, campers, etc. Maintain all specified clearances from combustibles, propane bottles, gasoline containers and similar flammable materials. Install this equipment per the product manual supplied with the heater. Propane has a strong odor, if you smell propane gas, DO NOT strike a match or lighter. Turn off all controls, allow at least 5 minutes for vapors to disperse, then check the equipment for leaks and proper operation per the operating instructions located within the product manual. If a leak cannot be found and odor is still present, have the equipment checked by a qualified service technician.

OPERATION INSTRUCTIONS	
START UP:	SHUT DOWN:
1. Connect 1690D to regulated propane supply.	1. Turn off the propane cylinder valve & allow fuel to burn off.
2. Plug 1690D into power source. 120VAC, 60Hz	2. Turn the heater switch to "OFF".
3. Place the 1325D Blower in-line and plug into the 120VAC receptacle located on the heater.	3. Allow the 1325D Blower to operate for 3.5 minutes in order to cool down the heat exchanger.
4. Install an 8" diameter x 15' long duct onto the outlet of the heater.	4. Unplug the 1325D Blower from the 1690D and remove the 1690D from the power and fuel sources.
5. Turn the heater switch to "ON".	

P/N: 118618-001

Figure 2b: #1690D Serial Number Plate

3.0 - Configuration & Assembly

Upon initial receipt of the #1690D In-Line Heater, inspect the packaging for any evidence that the product may have been damaged in shipment. While unpacking the product, inspect all of the components for damage. If damage to any of the components is discovered, alert the shipping carrier immediately of the damage to the shipment.

3.1 Parts Diagram & List

Refer to the following parts breakdown diagram (Figure #3.1a) and the accompanying parts list (Table #3.1a) for identification of parts in the event replacements become necessary. The parts list table displays applicable part numbers, descriptions, and quantity per assembly.

**Refer to parts list below if replacement parts are required. Replacement parts can be ordered from the T.A. Pelsue Company at 800-525-8460.

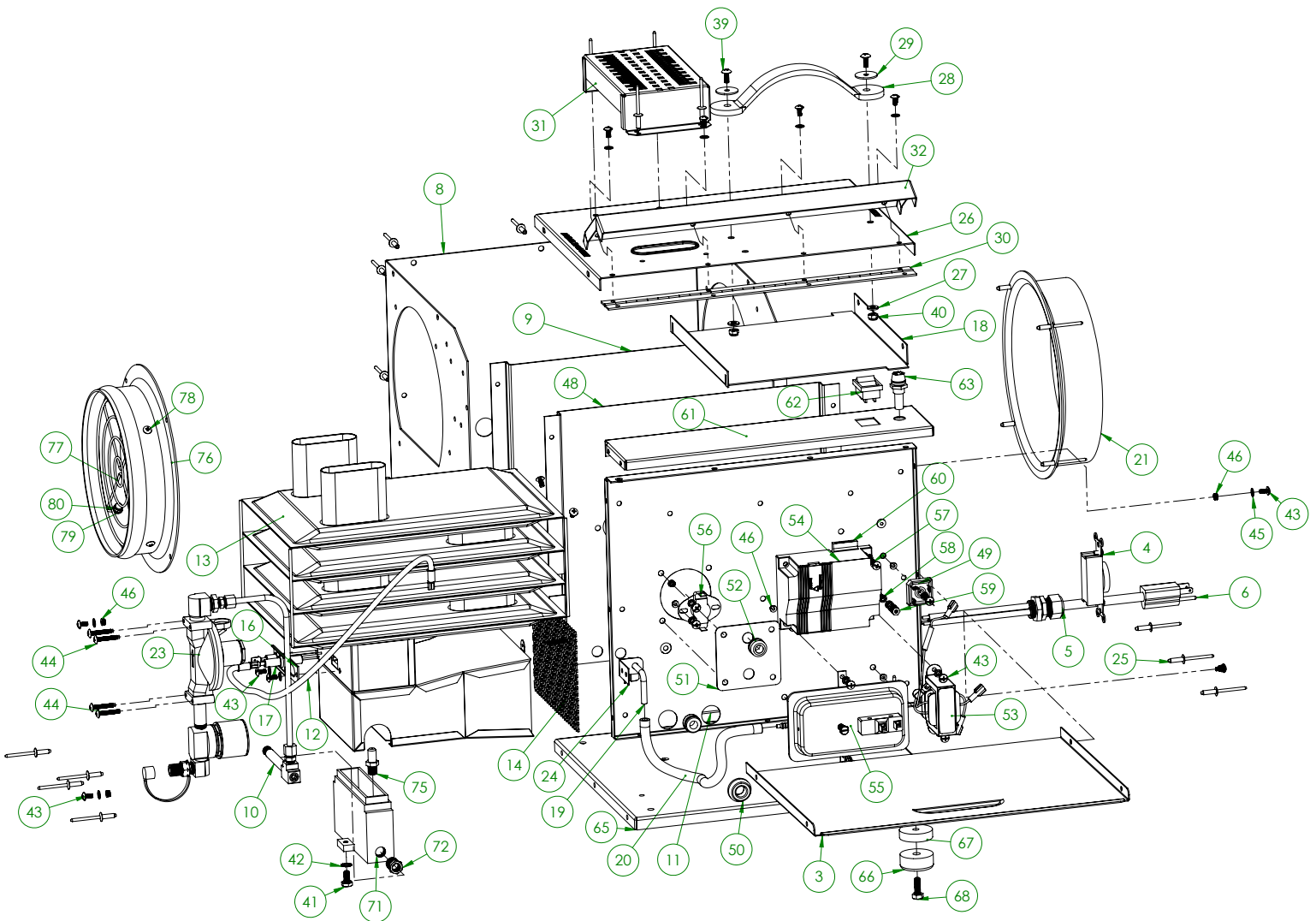

Figure 3.1a: #1690D
Parts Diagram

3.1 Parts Diagram & List (continued)

ITEM NUMBER	PART NUMBER	DESCRIPTION	QUANTITY
3	111487-001	DOOR - CONTROL BOX ACCESS	1
4	26E-007000	RECEPTACLE - 2 POLE, 3 WIRE, 15 AMP, 125V, FLUSH, STRAIGHT BLADE	1
5	100405-004	STRAIN REL - 1/2" HUB, 0.250"- 0.375" DIAMETER	1
6	26E-005700	CORDSET - W/MOLDED PLUG 16/3 SJTOW RATED	1
7	44E-017900	PLUG - SNAP-IN BLANK BUTTON, 7/8" DIAMETER	1
8	118649-001	MAIN HOUSING - HOUSING ASSEMBLY, SILKSCREENED W/ PELSUE LOGO	1
9	118652-002	PANEL - HEAT SHIELD - SUB ASSEMBLY	1
10	112450-001	FITTING - NIPPLE, 1/8" MNPT X 3.50" LONG, BRASS	1
11	118654-002	MAIN BASE PLATE - HOUSING ASSEMBLY	1
12	120423-001	LEAD - HIGH TENSION, SPARK IGNITION	1
13	118574-001	HEAT EXCHANGER WELDMENT, WITH AIR COLLECTOR	1
14	120429-001	SCREEN - AIR COLLECTOR	1
15	113929-001	SIGHT GLASS - 1/2" NPT, CLEAR LENS, HEX HEAD, ELECTRO-PLATED	1
16	106860-001	GASKET - SPARK IGNITER/FLAME SENSOR	1
17	106031-001	SPARK IGNITER - IGNITER/FLAME SENSOR ELECTRODE	1
18	120430-001	PANEL - HEAT SHIELD, TOP	1
19	120461-001	PITOT TUBE - WELDMENT W/ MOUNTING BRACKET	1
20	112203-000	TUBING - RD, BLACK RUBBER, 7/32" NOMINAL DIAMETER	1
21	106857-002	RING - INNER, INTAKE, AS MODIFIED	1
22	62I-006800	HOSE ASSY - LPG, 1/4" X 10' LENGTH, 9/16" L.H. FEMALE ENDS (NOT SHOWN)	1
23	120468-B01	REGULATOR - SUB ASSEMBLY, AS INSTALLED	1
24	44E-035100	CLAMP - TUBING, 1/2" ID, VINYL COATED ALUMINUM STRAP	1
25	118518-001	RIVET - STAVEX, BLIND FLANGE DOME, BLACK, 0.188" DIAMETER	57
26	118653-001	TOP PANEL - HOUSING ASSEMBLY	1
27	100050-006	WASHER - FLAT, #10, TYPE A, W, PLATED	2
28	102090-001	HANDLE - BLOWER, CLOTH REINFORCED NEOPRENE, 10.25" X 1.50"	1
29	105558-001	WASHER - FENDER, #10, TYPE A. W. PLATED	2
30	111490-001	HINGE - CONTROL PANEL COVER	1
31	118294-001	CHIMNEY WELDMENT - FOR INLINE HEATER	1
32	118657-001	COVER - CONTROL PANEL	1
33	120459-001	DECAL - WIRING DIAGRAM, LADDER DIAGRAM, NOTES & LEGEND (NOT SHOWN)	1
34	107343-001	DECAL - ELECTRICAL GROUNDING INSTRUCTIONS (NOT SHOWN)	1
35	110292-001	DECAL - WARNING, GENERAL HAZARD (NOT SHOWN)	1
36	110290-001	DECAL - WARNING, UNIT USAGE (NOT SHOWN)	1
37	110289-001	DECAL - WARNING, HAZARDOUS CONDITIONS (NOT SHOWN)	1
38	118618-001	DECAL - IDENTIFICATION, RATING & SERIAL #, BLK/SILVER (NOT SHOWN)	1
39	111841-002	SCREW - MACHINE TRUSS HEAD, #10-24 UNC X 1/2" LG, BLACK	2
40	112178-001	LOCKNUT - NYLON INSERT, #10-24 UNC, BLACK OXIDE	2
41	100604-005	SCREW - HEX HD, 1/4"-20 UNC X 1/2", PLATED, GRADE 5	1
42	68N-015900	WASHER - LOCK, EXTERNAL TOOTH, 1/4"	1
43	68N-002800	SCREW - MACHINE, PHIL TRUSS HD, #8-32 UNC X 3/8" PLATED	16
44	111844-010	SCREW - MACHINE, PHIL TRUSS HD, #8-32 X 1" LONG, BLACK	6
45	68N-004300	WASHER - LOCK, INTERNAL TOOTH, #10, PLATED	10
46	107013-002	NUTSERT - THIN SHEET, #8-32, CRIMP-IN STYLE	11
47	120468-001	PANEL - CONTOL BOX, INTERIOR COMPONENT WALL	1
48	120469-001	PANEL - HEAT SHIELD, COMPONENT WALL	1
49	106763-001	RECTIFIER - BRIDGE	1
50	62E-023500	GROMMET - RUBBER, 1/2" ID X 1.0625" OD, 7/8" GROOVE DIAMETER	1
51	111492-001	PLATE - ACCESS, THERMAL LIMIT SWITCH	1
52	62E-011200	GROMMET - RUBBER, 3/8" ID X 3/4" OD	2
53	123762-001	TRANSFORMER - 117VAC PRIMARY	1
54	118566-001	CIRCUIT BOARD - LPG IGNITER 23VDC, 1-TRY, 0-PURGE, 7-SECOND (TFI)	1
55	120421-001	SWITCH - AIR PRESSURE, NORMALLY OPEN	1

**Table 3.1a: #1690D
Parts List**

3.1 Parts List (continued)

ITEM NUMBER	PART NUMBER	DESCRIPTION	QUANTITY
56	120422-001	SWITCH - THERMAL (CUT-OFF), 115 VAC, NORMALLY CLOSED	1
57	68N-023500	SCREW - MACHINE, TRUSS HD, #8-32 UNC X 3/4" PLATED	4
58	68N-004200	WASHER - LOCK, INTERNAL TOOTH, #8, PLATED	13
59	100048-006	NUT - HEX, #6-32 UNC, PLATED	3
60	26E-041310	CABLE ASSEMBLY - CIRCUIT BOARD, CONNECTS TO CONTROL COMPONENTS	1
61	118650-001	CONTROL PANEL - HOUSING ASSEMBLY	1
62	120959-001	SWITCH - ROCKER, SPST, 125/250 VAC 20A, 14VDC 14A	1
63	107336-001	FUSE HOLDER - PANEL MTD. W/ 90° MALE SPADE TERMINAL	1
64	121160-001	DECAL - VENTILATION BLOWER...MUST BE ATTACHED (NOT SHOWN)	1
65	118654-001	MAIN BASE PLATE	1
66	100188-002	FOOT - RUBBER, 1-1/2" OD W/REC WASHER	4
67	62Q-001000	WASHER - 23/64" THK. X 5/16" ID X 1-1/2" OD	4
68	101427-002	SCREW - CAP, HEX HD, 1/4"-20 UNC X 3/4" PLATED	4
69	100050-009	WASHER - FLAT, 1/4" IN, TYPE A, W, PLATED	4
70	100048-114	LOCK NUT - HEX, 1/4"-20, NYLON INSERT	4
71	118671-001	BURNER CASTING - AS MACHINED	1
72	108601-001	FITTING - REDUCER BUSHING, 1/4" MNPT X 1/8" FNPT	1
73	120425-001	BAFFLE - BURNER MANIFOLD	1
74	121107-002	SCREW - #8 X 3/8" LG. SELF TAP'G TYPE-F, CUTTING, HEX WASHER HD	1
75	120420-001	ORIFICE - #56 (.0465 DIA) ROUND BARREL PLUG, 1/8"-27 MNPT X 1 3/16" LG	1
76	106858-002	INNER RING - OUTLET SPINNING, PELSUE YELLOW	1
77	111330-001	GRILLE - OUTLET, PLATED IN BLACK OXIDE	1
78	111844-001	SCREW - MACHINE, PHIL TRUSS HD, #8-32 UNC X 3/8", BLACK	4
79	100050-005	WASHER - FLAT, #8, TYPE A, W, PLATED	4
80	100060-007	LOCKNUT - #8-32 UNC, NYLON INSERT	4

Table 3.1a: #1690D
Parts List (continued)

3.2 Ladder and Wiring Diagram

The ladder diagram, below in Figure 3.2a, demonstrates the stepped-down voltage of the control panel and ignition system, and the relationships between each of the safety switches.

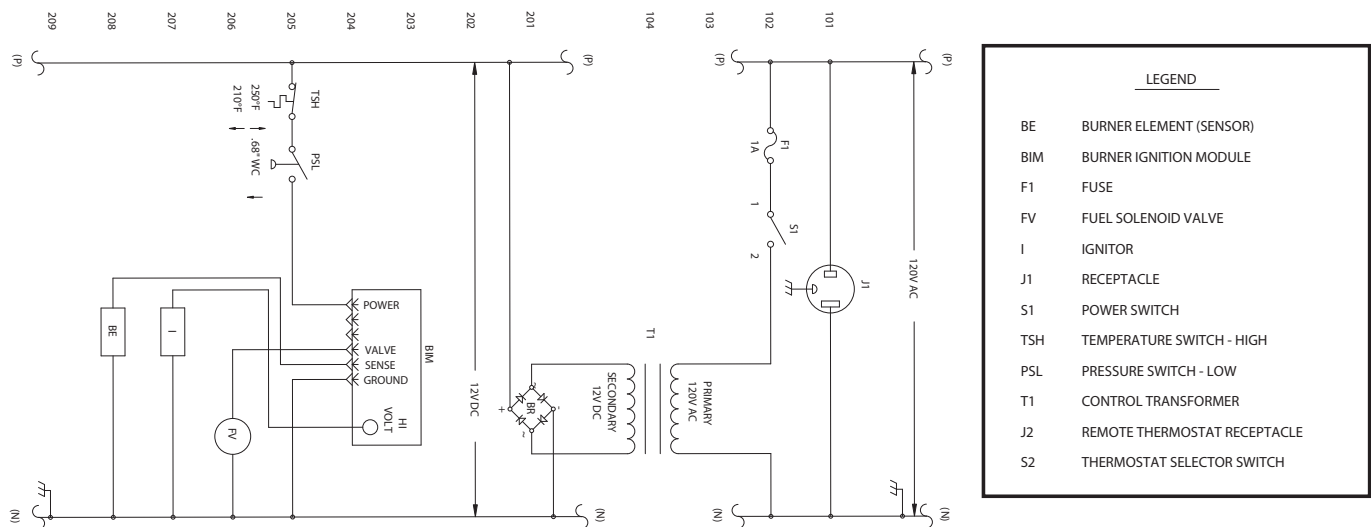

Figure 3.2a: #1690D
Ladder Diagram and Legend

3.2 Wiring Diagram

Shown below in Figure 3.2b, is a wiring diagram of the control box, cordset, and ignition system.

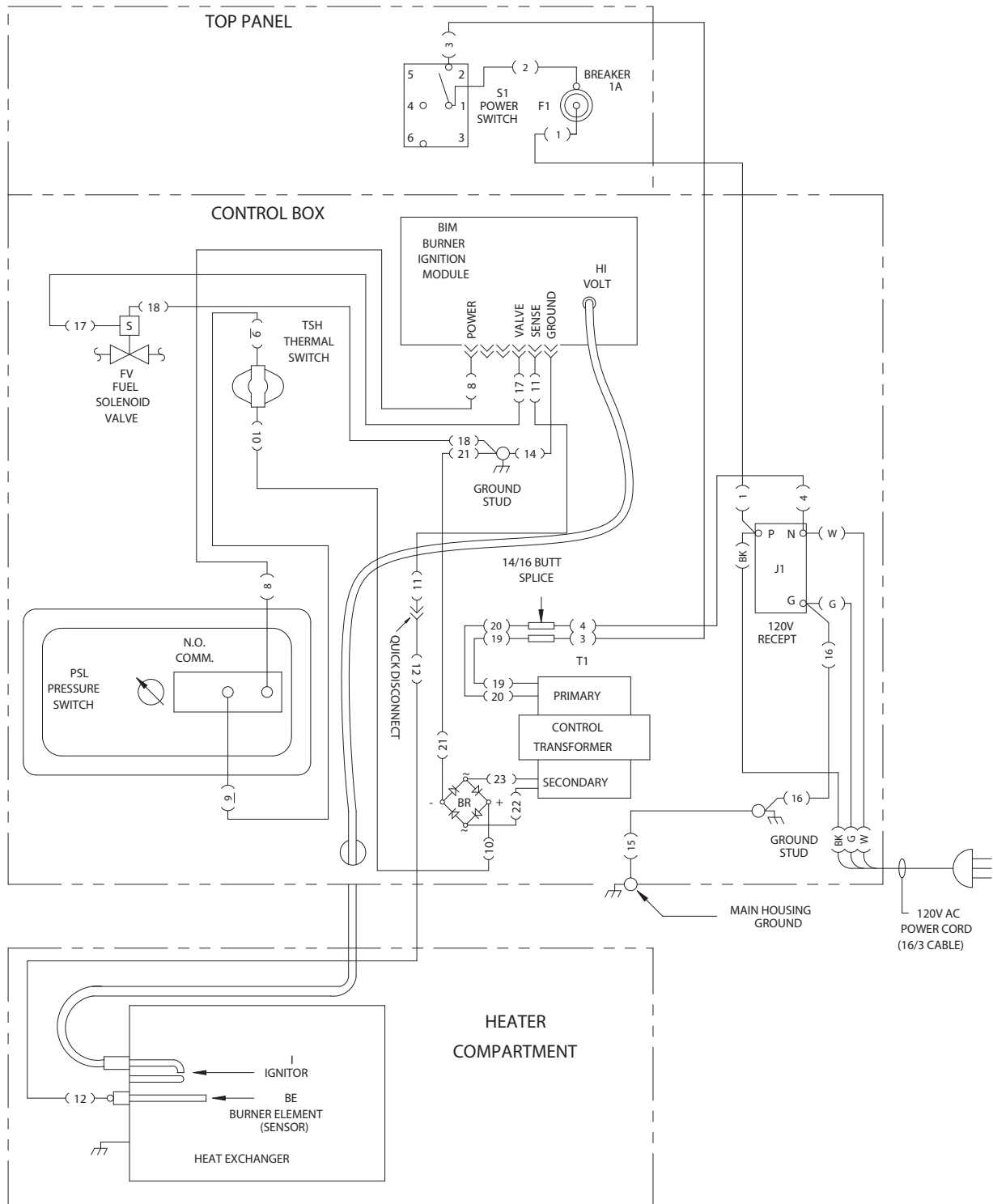

Figure 3.2b: #1690D
Wiring Diagram

4.0 - Safety

The following section will address the safety precautions which must be adhered to when working with Pelsue Construction Heating and Ventilation equipment such as the #1690D In-Line Heater. Any user must familiarize themselves with the information in this section before utilizing the equipment.

SIGNAL WORDS:

Note the use of the signal words **DANGER**, **WARNING** and **CAUTION** with the safety messages. The appropriate signal word for each message has been selected using the following guidelines:

- DANGER-** Indicates an imminently hazardous situation that, if not avoided, will result in death or serious injury. This signal word is to be limited to the most extreme situations or for hidden or unseen hazards.
- WARNING-** Indicates a potentially hazardous situation that, if not avoided, could result in death or serious injury and includes obvious and hidden hazards. It may also be used to alert against unsafe practices.
- CAUTION-** Indicates a potentially hazardous situation that, if not avoided, may result in minor or moderate injury. It may also be used to alert against unsafe practices.

You are responsible for the safe operation of your Pelsue #1690D In-Line Heater. You must ensure that anyone who will operate or work around the equipment be familiar with confined space ventilation procedures. This manual will take you step-by-step through the workings and capabilities of the #1690D In-Line Heater and alert you to all good safety and operating practices while using the system.

Remember, you are the key to safety. Good safety practices not only protect you but also the people around you. Make these practices a working part of your safety program. Be certain that everyone operating in or around a confined space is familiar with the procedures recommended and follows safety precautions. Remember, most accidents can be prevented. Do not risk injury or death by ignoring good safety practices.

- The most important safety device on this equipment is a safe operator. It is the operator's responsibility to read and understand all safety and operating instructions in the manual and to follow these. Most accidents can be avoided.
- A person must understand the operation of this equipment and be trained in it's usage before operating the equipment. An untrained operator exposes himself and others to possible serious injury or death.
- Do not modify the equipment in any way. Unauthorized modification may impair the function and/or safety and could affect the life of the equipment.
- Think SAFETY! Work SAFELY!

4.1 - Safety Alert Symbol

SAFETY ALERT SYMBOL

This Safety Alert symbol means **ATTENTION! BECOME ALERT! YOUR SAFETY IS INVOLVED!**

The Safety Alert symbol identifies important safety messages on your Pelsue Confined Space Product and in the manual. When you see this symbol, be alert to the possibility of personal injury or death. Follow the instruction in the safety message.

Why is this symbol important to you?

- 3 BIG Reasons:**
- Accidents Disable and Kill.**
 - Accidents Cost You Money.**
 - Accidents Can Be Avoided.**



Safety Precautions:

It is necessary to follow these safety precautions, each time, prior to using the product.

The Safety Precautions are not limited to, but must include the following items;

1. Do not use the heater for anything other than its intended use. The heater is primarily intended for the temporary heating of manholes, vaults, and buildings under construction or repair.
2. Do not wear loose clothing that can become entangled in operating machinery. Do not operate the heater without inlet or outlet screen guards in place. Do not place fingers or any other object through inlet or outlet screens.
3. Heater and fuel supply installation must conform with local codes, or in absence thereof, with ANSI/NFPA 58-1986 (or CAN/CGA B149.2 in Canada). The heater can be connected to any liquid propane (vapor) cylinder which meets the requirements of those standards. Always keep the propane cylinder in an upright position. Avoid subjecting propane cylinders to excessive heat; never direct heater outlet toward any propane cylinder.
4. Propane gas is very flammable. Commercial propane is scented such that its strong odor is readily detectable. If gas odor is detected at any time, do not operate or continue to operate the unit until the source of the gas odor has been located. In the event of a leak, propane is heavier than air, and will accumulate in low areas. **Never strike a match, create a spark, or a flame when you smell gas.** Move the heater outside and ventilate the area. Find and correct the the source of the leak before attempting to light the heater. If the leak cannot be corrected, do not tamper with the heater. Turn the heater off, as well as the valve to the gas cylinder, and consult a qualified technician.
5. The propane cylinder which supplies fuel to the heater shall incorporate an inline filter, regulator, and excess flow valve (per UL 125-1980). Supply pressure must be regulated down to input requirements of 15-50 psi. Regulator assemblies are available through the Pelsue Company, but are not supplied with this appliance.
6. Always operate the heater from a proper three-pronged ground fault interrupter receptacle.
7. Never let extension cords or plug connections lay in water. Locate the heater so that it cannot fall into water inadvertently; ensure that the heater is level and stable. Never handle energized power cords with wet hands.
8. Never use cords with frayed, cut, or brittle insulation. Check the cord for sound connections to the ground fault interrupter receptacle.
9. Never use this heater in an explosive environment.
10. Ensure that toxic fumes are not blown into a confined space.
11. Unattended use of equipment is not recommended.
12. Do not move, handle, or service the unit while hot or burning. Permanent skin tissue damage can occur if contact is made with the unit. Let the heater cool down after it has been shut off.
13. Heater should be inspected before each use, and at least annually by a qualified service agency.



! CAUTION ! - Be sure the heater is disconnected from the power source before doing any maintenance or repair work on the blower.

! CAUTION ! - Check all power cords for cuts, frayed ends, or brittle insulation. See parts list for replacement cord part number.

! CAUTION ! - The user must ensure that the heater is located where it cannot fall into water inadvertently and the extension cords or plug connections do not lay in water.

5.0 - Product Operation

The following section will address the capabilities and the general operation of the Pelsue #1690D Construction Heater. The instructions contained within this section should be adhered to each and every time the product is used. Any person tasked with installing or operating this piece of equipment should be familiar with these procedures.

5.1 - Product Description & Capabilities

The Pelsue #1690D Construction Heater is built with a lightweight, rugged aluminum housing and internal stainless steel heat exchanger, specifically designed for confined space applications. A control box on the side of the heater contains a transformer, electronic ignition controller, regulator, solenoid valve, pilot light, ON-OFF switch, air pressure differential switch, high-limit switch, and power cordset. All specifications, instructions, and procedures provided within this manual or upon Pelsue Specification Documents are based upon and only valid for usage with Pelsue accessories. The T.A. Pelsue Company cannot verify equipment safety and/or compliance when utilized with anything other than Pelsue approved confined space accessories.

Construction Heater - #1690D

General Specifications

• Weight	-	30 LBS.
• Height	-	15.25"
• Width	-	13.5"
• Length	-	18.5"

Clearance Requirements

Inlet:	24"
Sides:	24"
Above:	18"
Outlet:	60"
Outlet w/ hose:	24"

Model Specifications & Performance

#1690D

• Voltage	120VAC, 60Hz
• Amperage	1A (when connected to a 1325D Blower, combination requires 4A)
• BTU	70,000
• Heat Rise	100 °F

Features:

- Low Maintenance
- Specifically designed to provide a completely portable source of fresh heated air

Materials & Construction

- Main Structure: - Aluminum
- Heat Exchanger - Stainless Steel
- Hardware - Plated Steel

Additional Requirements & Notes

- The #1690D Construction Heater requires the use of a blower and 8" ventilation hose, in conjunction with the heater, to direct the heated air into confined spaces. The #1690D Heater is not to be used stand-alone in a confined space under any circumstances.

!WARNING! - The user must ensure that the power cord is correctly installed in order to prevent damage to the product and injury to the operator.



Figure #5.1a: #1690D
Inlet side of Heater

5.2 - Start-Up & Operating Procedures

Prior to Operation, the #1690D In-Line Heater should be configured and prepared according to the following guidelines.

1. Pre-Operation Inspection:

It is necessary to perform a visual inspection, each time, prior to using the product. If deficiencies are found, remove the product from service and contact T.A. Pelsue regarding repair. The following checklist coupled with *Figure #5.2a* should be used as a guide to determine whether the equipment is in good operating condition prior to usage. Equipment that is not in good condition can endanger the safety of the entrant and attendant during use.

The Pre-Operation Visual Inspection is not limited to, but must include the following items;

- a. Ensure that the heater switch is "OFF" and that the cordset is properly attached to the heater.
- b. Check the heater inlet as well as outlet and chimney guard screens for obstructions. Remove any objects around the immediate area that could be sucked into the heater.
- c. Confirm that the rubber feet are attached.
- d. The hose assembly must not show signs of excessive abrasion or wear, and must not be cut, torn or knicked. If any of these conditions exist, replace the hose assembly prior to using the heater.

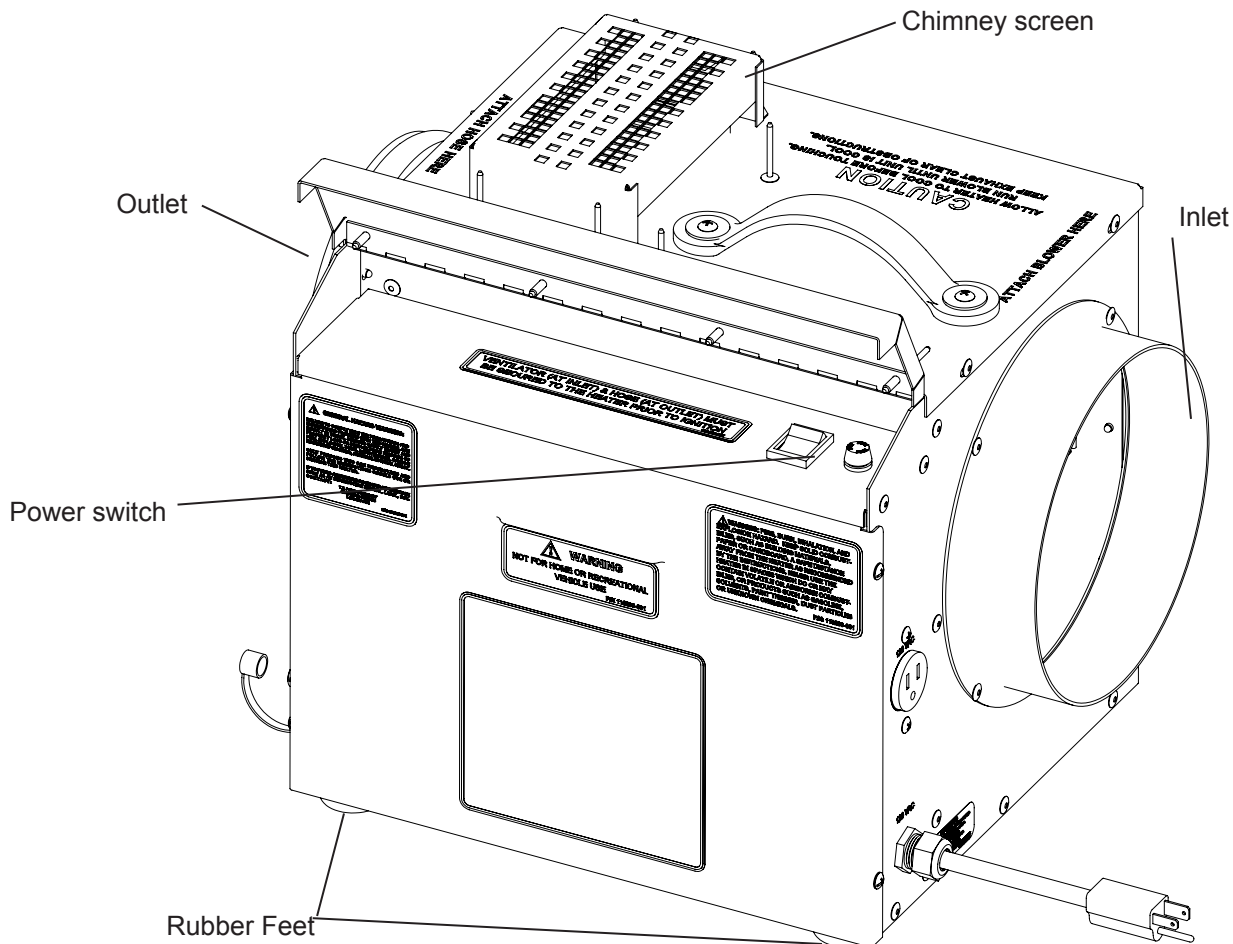

**Figure #5.2a: #1690D Construction Heater
Pre-Operation Inspection Points**

5.2 - Start-Up & Operating Procedures (continued)

2. Setup of 1690D Construction Heater:

Choose a location where installation will provide suitable proximity to the work area yet minimize obstructions during use, and in the event a rescue is necessary. Once a location is chosen:

- a. An appropriate Pelsue blower (i.e. 1325D) should be connected to the inlet of the heater and the combined heater blower setup should be 1.5 meters (approximately 5 feet) upwind -- where possible -- from the confined space, with the blower inlet pointed into the wind. This will reduce the chance of contamination being blown into the confined space. (Refer to Fig. #5.2b)
- b. Plug the heater power cord into a properly grounded receptacle, and the blower power cord into the heater receptacle. The blower will run continuously, despite the power on the heater being switched "Off".
- c. Connect the LPG cylinder to the heater via the pre-inspected hose assembly. Fully open the valve on the propane bottle. Turn the heater control switch to the "On" position. A 4 second delay will facilitate a safety purge of the combustion chamber. After this delay the ignition should spark, and the heater should fire. Allow ventilator to purge the duct for 1 minute before installing end of hose into any confined space.
- d. When heater operation is no longer required turn off the propane gas at the source first, to burn off residual fuel in the gas line. Then switch off the power on the heater. Allow the blower to run for five minutes to cool off the heat exchanger. Remove the blower power cord from the heater receptacle, and the heater power cord from the grounded receptacle. Finally, remove the blower and the hose.

Important Notes:

- During confined space entry operations, it should not be assumed that the ventilator will maintain the air inside the confined space at a safe condition. When the ventilator is in use, the air inside the confined space should be monitored continuously for the presence of poisonous gases and/or toxic fumes.
- Ensure that the blower provides positive airflow the entire time during usage. The blower can be used with an accessory Pelsue Air Flow Alarm (#123717-001) in order to alert the entrants if positive ventilation is lost

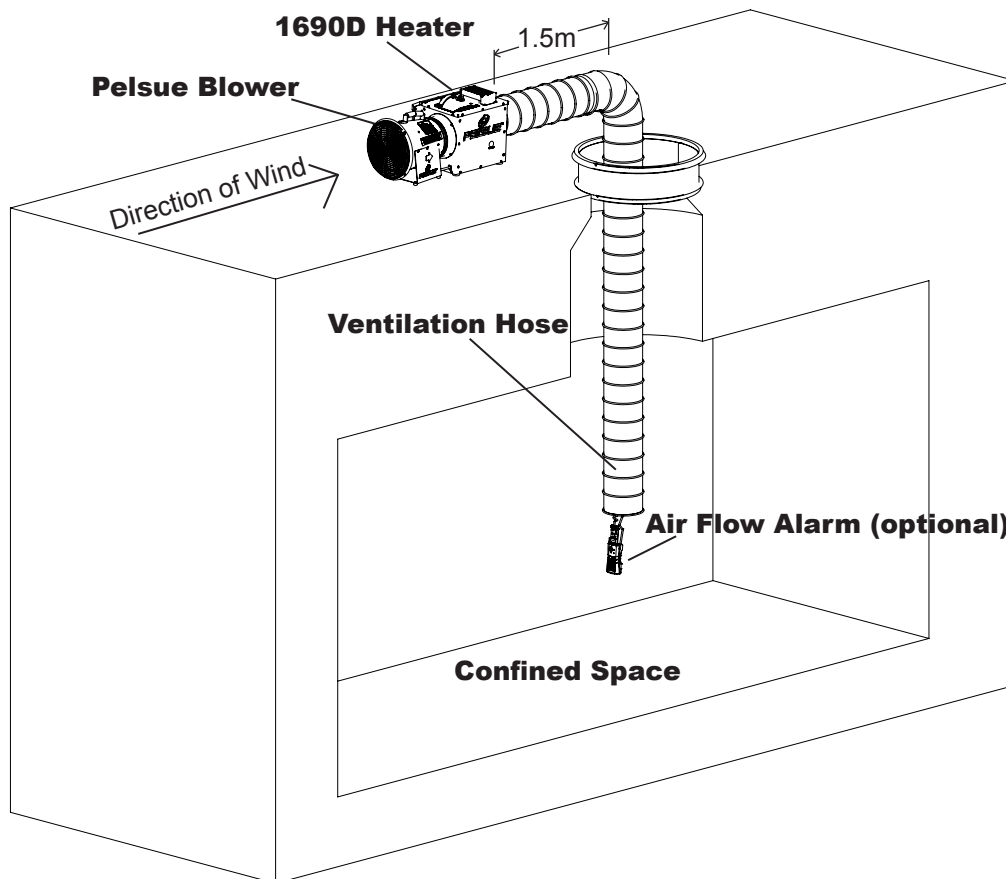

Figure #5.2b: 1690D Heater with Blower Setup in Confined Space

6.0 - Troubleshooting

SYMPTOM	CAUSE	REMEDY
Gas will not ignite when burner is turned on and spark is present	<ol style="list-style-type: none"> 1. LPG bottle is empty 2. Faulty solenoid valve 3. Faulty regulator 4. LPG cylinder valve is shut 5. Obstruction of heater outlet 6. Fuel pressure to manifold is too low 	<ol style="list-style-type: none"> 1. Fill LPG cylinder 2. Replace solenoid valve 3. Replace regulator 4. Open valve to "on" position 5. Remove blockage 6. Reset pressure to manifold to 10.5" W.C.
Erratic flame at burner	<ol style="list-style-type: none"> 1. Orifice(s) loose or dirty 2. Loose connections in fuel line plumbing 	<ol style="list-style-type: none"> 1. Tighten and / or clean orifice 2. Check and tighten connections leading to the burner box
Flame will not go out when burner is switched off.	<ol style="list-style-type: none"> 1. Faulty or dirty solenoid valve 2. Circuit board failure 	<ol style="list-style-type: none"> 1. Clean or replace solenoid valve 2. Replace circuit board
No spark when control switch is turned on	<ol style="list-style-type: none"> 1. Circuit board has locked out system for safety reasons 2. Circuit board failure 3. Pressure switch faulty or "off" 	<ol style="list-style-type: none"> 1. Re-cycle the heater ignition system by turning "off" power switch for 30 seconds 2. Replace circuit board 3. Check to be sure blower is on, otherwise replace pressure switch
Burner lights for 3-4 seconds, and then shuts off	<ol style="list-style-type: none"> 1. Circuit board failure 2. Flame sensor failure 	<ol style="list-style-type: none"> 1. Replace circuit board 2. Replace flame sensor / spark igniter unit
Yellow flame	<ol style="list-style-type: none"> 1. Dirty orifice(s) 	<ol style="list-style-type: none"> 1. Clean orifices

7.0 - Storage

Prior to storage, the heater should be thoroughly inspected and maintained. Repair or replace any worn or damaged components to prevent any unnecessary down time at the next use.

Follow this procedure:

1. Visually inspect daily for oil or liquid fuel contaminant present in the heater or fuel supply hose. If any is evident, heater should be cleaned and / or repaired by a qualified technician before use.
2. If the heater has not been in service for a long period of time, the following procedure should be initiated before placing it back into operation. Use an air hose (not to exceed 30 psi) to blow off any dust/dirt that has accumulated on the heater. Pass the air hose over the chimney, inlet, and outlet. (Vacuuming is acceptable)
3. Wipe the housing clean using a soap and water solution or a nonabrasive aluminum cleaner.
4. If a malfunction in the pressure regulator or safety shut-off control valve is found after placing the heater into operation, consult the factory or an experienced heating contractor for repair or replacement.

8.0 - Contact Information

For More Information...



**T.A. Pelsue Company
2500 S. Tejon St.
Englewood, CO 80110**

**Toll Free: 1-800-525-8460
Telephone: 1-303-936-7432
Fax: 1-303-934-5581**

Website: www.pelsue.com

Email: sales@pelsue.com



T.A. Pelsue Company

2500 South Tejon Street, Englewood, Colorado, USA 80110
Toll free 800-525-8460 or 303-936-7432 Fax. 303-934-5581
Internet: www.pelsue.com Email: sales@pelsue.com