

Part #107077-001

# Product Manual:

Model #1590

Construction Heater / Blower

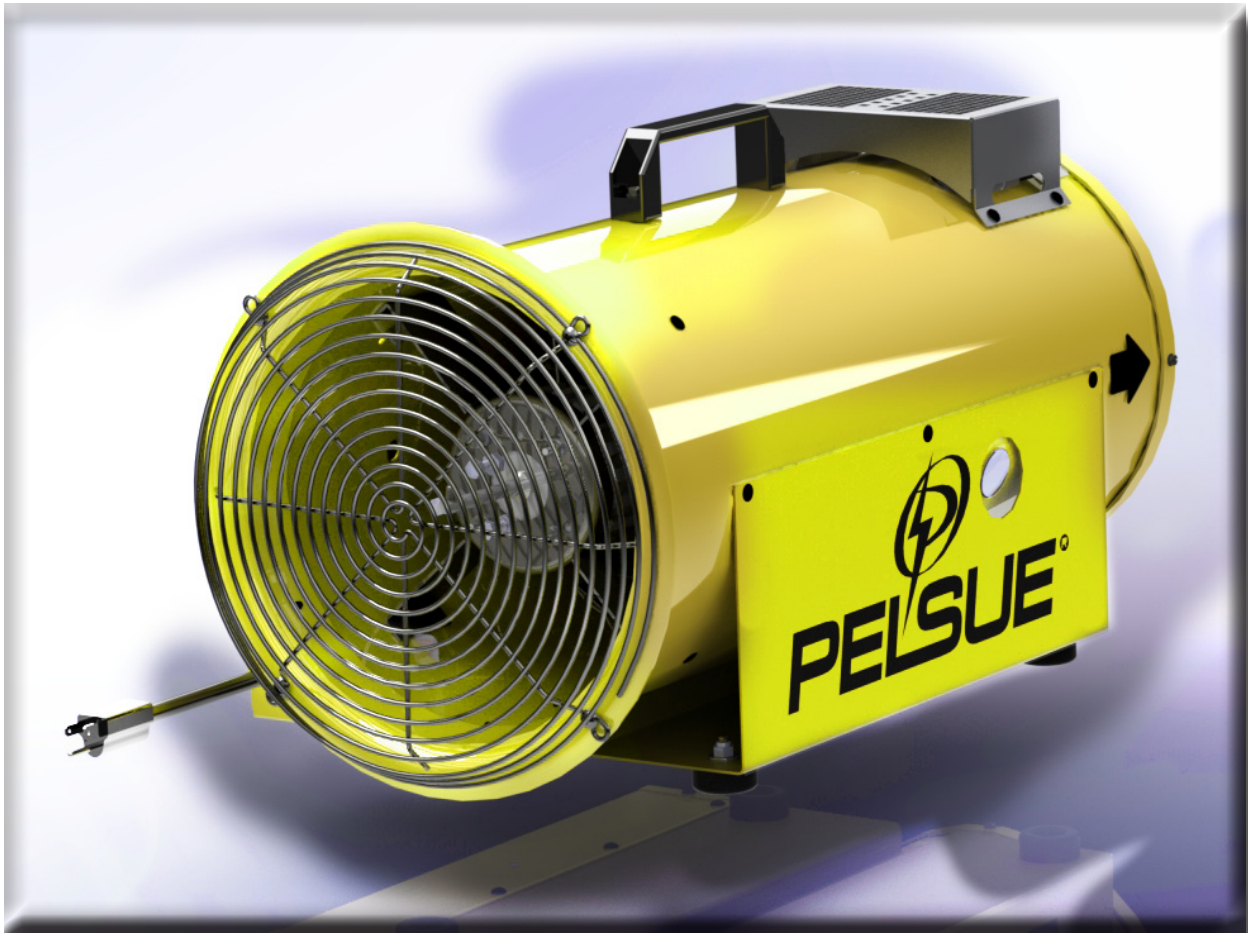

  
**PELSUE**<sup>®</sup>

*ISO 9001 Certified*

**T.A. Pelsue Company**

2500 South Tejon Street

Englewood, Colorado, USA 80110

Tel. 800-525-8460 or 303-936-7432

Fax. 303-934-5581

Internet: [www.pelsue.com](http://www.pelsue.com)

Email: [sales@pelsue.com](mailto:sales@pelsue.com)



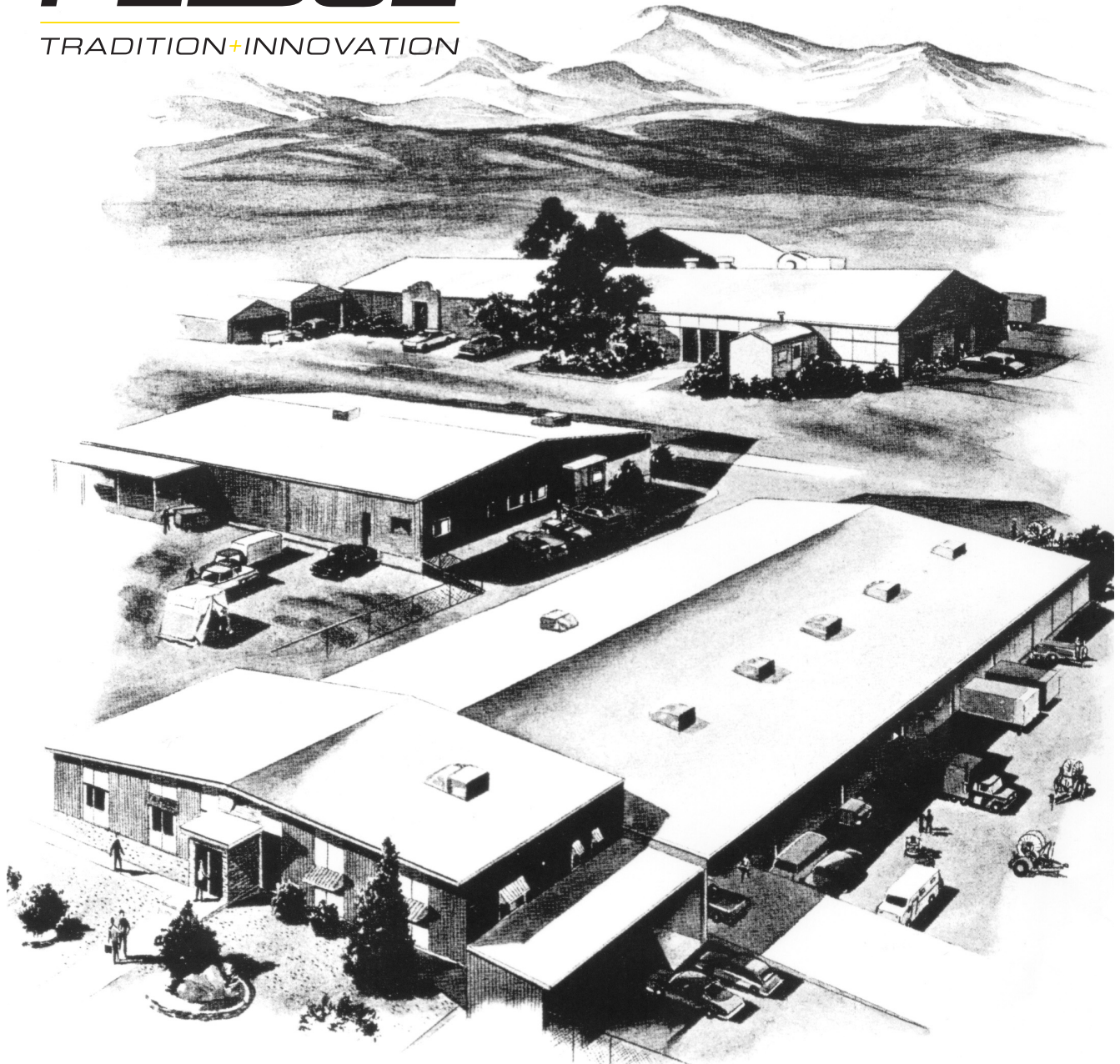

Since our inception in 1963 – the T.A. Pelsue Company has designed and manufactured high quality equipment to improve the personnel efficiency and working conditions in various underground, confined, and outdoor areas.

Founded by T. Allen Pelsue, the company has established a continuing reputation for excellence in the production of fine products for a broad spectrum of industry throughout the world.

Now, in our second generation of family direction, continued commitment to innovation and quality makes Pelsue a leading source of equipment for many types of confined spaces. We specialize in safety, retrieval, fall arrest, ventilation, cable placing, splicing, and maintenance nationally and abroad. With more than 70,000 square feet of facilities available, Pelsue continues the dedication that has made it pre-eminent in this field.

# Table of Contents

---

<b>Section</b>	<b>Description</b>	<b>Page #</b>
<b>1.0</b>	<b>General Information</b>	<b>5</b>
1.1	Quality Policy	
1.2	Pelsue Product Warranty	
<b>2.0</b>	<b>Introduction &amp; Product Information</b>	<b>7</b>
2.1	Serial Number	
<b>3.0</b>	<b>Configuration &amp; Assembly</b>	<b>8</b>
3.1	Parts Diagram & List	
3.2	Wiring Diagram	
<b>4.0</b>	<b>Safety</b>	<b>13</b>
4.1	Safety Alert Symbol	
4.2	General Safety Information	
<b>5.0</b>	<b>Product Operation</b>	<b>15</b>
5.1	Product Description & Capabilities	
5.2	Start-Up & Operating Procedures	
<b>6.0</b>	<b>Troubleshooting</b>	<b>18</b>
<b>7.0</b>	<b>Storage</b>	<b>18</b>
<b>8.0</b>	<b>Contact Information</b>	<b>19</b>

### **T.A. Pelsue Company**

#### **Quality Policy**

OUR GOAL IS THE PURSUIT OF NEVER-ENDING IMPROVEMENT IN PRODUCT QUALITY AND BUSINESS SYSTEMS.

METHODS TO BE EMPLOYED IN ATTAINING THIS GOAL WILL INCLUDE NEW PRODUCT QUALITY PLANNING, EMPLOYEE TRAINING, AND UTILIZATION OF EMPLOYEE INVOLVEMENT GROUPS TO SOLVE PROBLEMS.

IN AN INCREASINGLY COMPETITIVE MARKETPLACE, ENSURING CUSTOMER SATISFACTION IS ONE OF THE DIFFERENTIATORS THAT SETS YOU APART FROM THE PACK AND YIELDS A COMPETITIVE ADVANTAGE.

THEREFORE, WE WILL SUPPORT TOTAL CUSTOMER SATISFACTION BY IMPLEMENTING THE **ISO 9001 QUALITY SYSTEM** AND PROVIDING THE NECESSARY ATMOSPHERE AND TRAINING TO NURTURE THIS CONCEPT THROUGHOUT OUR ORGANIZATION.

WE WILL MAKE EVERY BUSINESS DECISION AS THOUGH THE QUALITY OF THE PART OR SERVICE PROVIDED WAS DESTINED FOR OUR OWN OR OUR FAMILY'S USE. WE WILL ALWAYS THINK **QUALITY FIRST**.

EVERY T.A. PELSUE COMPANY EMPLOYEE IS EXPECTED TO COMMIT TO THIS PHILOSOPHY IN THE PERFORMANCE OF HIS OR HER DAILY TASKS.

#### **QUALITY FIRST!**

T.A. PELSUE COMPANY SENIOR MANAGEMENT TEAM

## 1.2 - Pelsue Product Warranty

### PELSUE PORTABLE PRODUCT WARRANTY

- Pelsue products are designed and engineered to perform as stated in published specifications. Quality materials and workmanship are used in the manufacture of this product. With regular maintenance and proper care, Pelsue equipment provides many trouble free hours of operation.
- The T.A. Pelsue Company warrants to the buyer that material furnished will conform to specifications and will be free from defects in material and workmanship from the date of shipment to the original buyer, for the period listed by product description, below this warranty statement.
- In the event of failure of any components of a Pelsue product within the warranty period, service must be pre-approved by the T.A. Pelsue Company and service must be performed by the T.A. Pelsue Company Parts and Service Department in Englewood Colorado, or at the option of T.A. Pelsue Company, service may be performed at any designated service center, which may include any authorized service center for the component manufacturers.
- Damage or failure due to misuse, mishandling, or unauthorized modifications will not be covered by this warranty. Unless otherwise agreed, the T.A. Pelsue Company shall repair or replace the defective components within (30) calendar days of notice of failure. T.A. Pelsue Company's obligation hereunder, shall be limited to the repair or replacement of the product or component as set forth above, and shall not include any liability whatsoever for damages caused by such failure, including but not limited to consequential or incidental damages flowing from use or lack of use of product.
- Any replacement, repair, modification, installation or other service performed by the T.A. Pelsue Company shall be warranted by the remainder of the unexpired period of the warranty, or for a period of (90) calendar days, whichever is longer.
- All materials or parts returned for credit or warranty shall be returned only with prior approval, and will be subject to factory inspection before credit is allowed. Parts claimed defective will be replaced upon request and will be invoiced as purchased, subject to credit when the parts claimed to be defective have been received and examined by the factory.
- This warranty is expressly in lieu of all other warranties expressed or implied, including any warranties of merchantability or warranties of fitness for any particular use and all other obligations or liabilities in connection with the sale of this equipment.

<u>Product Description</u>	<u>Warranty Coverage*</u>
• Ventilators.....	1 year
• Heaters.....	1 year
• Ventilator Hoses/Ducts.....	3 months
• Pel-Cans and Caddys.....	1 year
• Hose Adapters.....	1 year
• Manhole Shields & Manhole Guards.....	1 year
• Pel-Brite Work Lights.....	6 months
• Planks and Plank Supports.....	6 months
• Duct Rodders and Accessories.....	6 months
• Submersible Pumps.....	6 months
• Discharge and Suction Hoses for Pumps.....	3 months
• Wheel Chocks.....	1 year

\*From date of shipment to original buyer.

T.A. Pelsue Company, 2500 South Tejon Street, Englewood, Colorado 80110, 800-525-8460

## 2.0 - Introduction & Product Information

Congratulations on your choice of a **Pelsue Model #1590 Construction Heater / Blower**. The Pelsue Heater / Blower is specifically designed to provide means of heating ventilated shelters or work areas. Such use includes, but is not limited to Fire, Police & Hazmat response crews in bio-terror and mass casualty incidents. This equipment has been designed and manufactured to exceed durability requirements in order to meet the needs of the discriminating operator. Safe, efficient and trouble-free operation and maintenance of the system requires that anyone who will be operating, maintaining, or inspecting the equipment, read, understand and follow all the operation, safety, maintenance, and inspection instructions contained within this manual. This manual covers the Pelsue Model #1590 Construction Heater / Blower. Use the Table of Contents as a guide to find specific information.

Keep this manual available for future reference if required, and as a tool in the training of new operators.

! **WARNING**

This product is part of a system intended for usage in a climate control scenario. The user must read, understand and follow the instructions contained in this manual before using this equipment. Failure to follow these instructions could result in serious injury or death.

## 2.1 - Serial Number

### Product Serial Number



Always give your dealer the serial number of your Pelsue portable heater / blower product when ordering parts or requesting service or other information. The rating and serial number decal is permanently embossed with a serial number. The serial number decal is located on the control box cover, as shown in *Fig. 2a*. The serial number decal will appear as shown in *Fig. 2b*. A space has been provided below for the recording of the serial number for future reference.

MODEL: \_\_\_\_\_ **#1590**

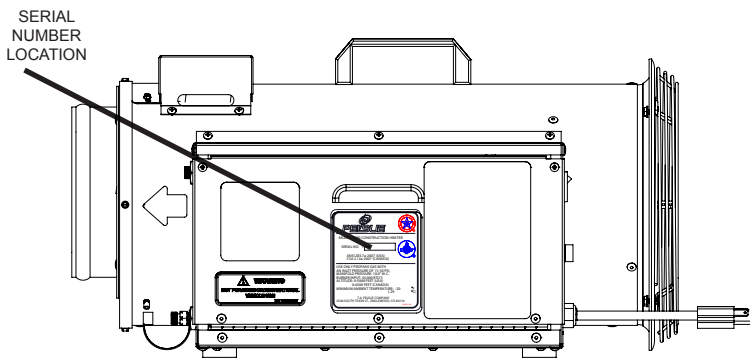
Serial Number : \_\_\_\_\_



**Figure 2a:** Serial Number Location



**MODEL 1590 CONSTRUCTION HEATER**

SERIAL NO. 1590-

ANSI Z83.7a-2007 (USA)  
CSA 2.14a-2007 (CANADA)



---

USE ONLY PROPANE GAS WITH  
AN INLET PRESSURE OF 15-50 PSI,  
MANIFOLD PRESSURE: 10.0" W.C.  
BURNER INPUT: 45,000 BTU'S  
ALTITUDE: 0-5000 FEET (USA)  
0-4500 FEET (CANADA)  
MINIMUM AMBIENT TEMPERATURE: -20 °F  
(-29 °C)

T.A. PELSUE COMPANY  
2500 SOUTH TEJON ST., ENGLEWOOD, CO 80110

106985-001

**Figure 2b:** #1590  
Serial Number Decal

## 3.0 - Configuration & Assembly

Upon initial receipt of the Model #1590 Construction Heater / Blower, inspect the packaging for any evidence that the product may have been damaged in shipment. While unpacking the product, inspect all of the components for damage. If damage to any of the components is discovered, alert the shipping carrier immediately of the damage to the shipment.

### 3.1 Parts Diagram & List

Refer to the following parts breakdown diagrams (Figures #3.1a-c) and the accompanying parts list (Table #3.1a) for identification of parts in the event replacements become necessary. The parts list table displays applicable part numbers, descriptions, and quantity per assembly.

\* Replacement parts can be ordered from the T.A. Pelsue Company at 800-525-8460.

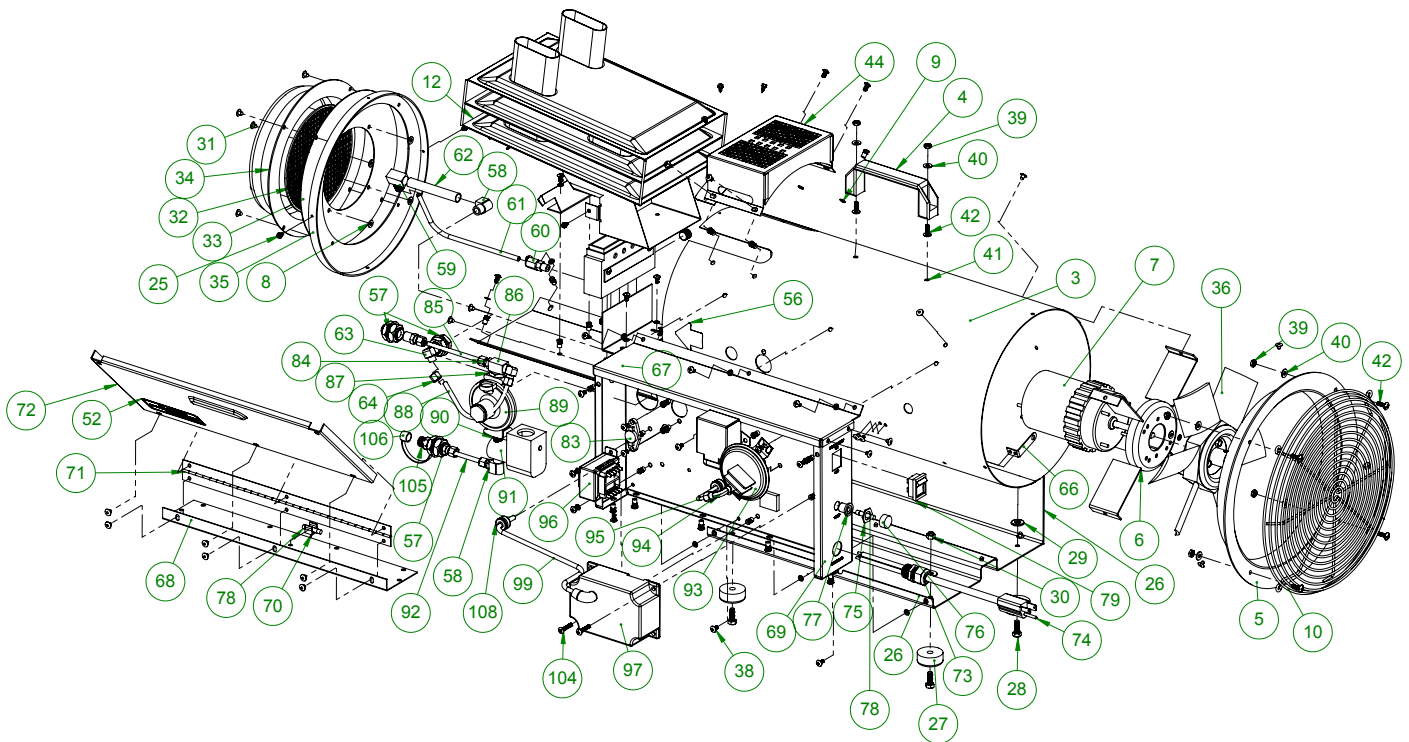

**Figure 3.1a: #1590**  
Parts Diagram

ITEM NUMBER	PART NUMBER	DESCRIPTION	QUANTITY
3	115410-001	HOUSING - SILKSCREENED	1
4	106942-001	HANDLE - PULL TYPE, BLK PLASTIC	1
5	103797-001	SPINNING - INTAKE, AS MODIFIED WITH MOUNTING HOLES	1
6	110283-001	MOTOR MOUNT - CUP TYPE FOR FASCO MOTOR	1
7	110002-001	MOTOR - ELECTRIC, 120VAC, 1/3HP	1
8	100050-005	WASHER - FLAT, #8, TYPE A, W, PLATED	8
9	68N-004200	WASHER - LOCK, INTERNAL TOOTH, #8, PLATED	40
10	104977-001	GRILLE - INTAKE POWDERCOATED BLACK	1
11	120174-001	PANEL - CLOSURE	1
12	106867-001	HEAT EXCHANGER	1
13	107298-001	SIGHT GLASS - 1/4" NPT, CLEAR LENS, HEX HD	1

**Table 3.1a: #1590**  
Parts List



### 3.1 Parts Diagram & List (continued)

ITEM NUMBER	PART NUMBER	DESCRIPTION	QUANTITY
14	107299-001	FITTING - ADAPTER, 1/4" NPT, HEX HD, THRU HOLE	1
15	107572-001	COUPLER - MERCHANT, 1/4" NPSF THRU, GALV.	1
16	107166-001	BAFFLE - MAIN BURNER	1
17	106860-001	GASKET - SPARK IGNITER/FLAME SENSOR	1
18	106031-001	SPARK IGNITER - IGNITER/FLAME SENSOR ELECTRODE	1
19	68N-002800	SCREW - MACHINE, PHIL TRUSS HD, #8-32 UNC X 3/8" PLATED	12
20	106636-002	BURNER - CASTING	1
21	106984-001	DEFLECTOR - AIR FLOW	1
22	106862-001	PLATE - HEAT EXCHANGER BASE	1
23	106869-001	SHUTTER - AIR	1
24	107128-001	ORIFICE - BRASS, 1/4"-28 UNF, DRILLED TO #59	5
25	112179-001	SCREW - SHEET METAL, #8 X 3/8", HEX HD SLOTTED	8
26	106978-001	PANEL - HEATER BASE, SILKSCREENED	1
27	100188-002	FOOT - RUBBER, 1-1/2" OD WITH RECESSED WASHER	4
28	101427-002	SCREW - CAP, HEX HD, 1/4"-20 UNC X 3/4" PLATED	5
29	100050-009	WASHER - FLAT, 1/4", TYPE A, W, PLATED	4
30	100048-114	LOCK NUT - HEX, 1/4"-20, NYLON INSERT	4
31	118518-001	RIVET - STAVEX, BLIND FLANGE DOME, BLACK, 0.188" DIA	35
32	107089-001	SCREEN - OUTLET	1
33	107310-001	RING - RESTRICTOR, 5" DIAMETER	1
34	106858-002	RING - INNER, OUTLET SPINNING	1
35	106856-002	RING - OUTER, INTAKE & OUTLET SPINNING	1
36	110001-001	FAN BLADE - POLYPROPYLENE, 10" DIA X .38" BORE	1
37	107013-002	NUTSERT - THIN SHEET, #8-32, CRIMP-IN STYLE	36
38	111844-001	SCREW - MACHINE, PHIL TRUSS HD, #8-32 UNC X 3/8", BLK	26
39	100048-008	NUT - HEX, #10-24 UNC. PLATED	10
40	100050-023	WASHER - FLAT, #10 SAE, ZINC PLATED	6
41	68N-004300	WASHER - LOCK, INTERNAL TOOTH, #10, PLATED	2
42	115166-001	SCREW - TRUSS HEAD, PHILLIPS, #10-24 X 5/8", BLK	6
43	44E-017900	PLUG - SNAP-IN BLANK BUTTON, 7/8" DIA	1
44	118292-001	CHIMNEY WELDMENT	1
45	110289-001	DECAL - WARNING, HAZARDOUS CONDITIONS (NOT SHOWN)	1
46	121250-001	DECAL - "CAUTION: WHEN REMOVING..." (NOT SHOWN)	1
47	121251-001	DECAL - "CAUTION: FAN SHOULD BE..." (NOT SHOWN)	1
48	121252-001	DECAL - "NOTICE: WHEN USING HEATER..." (NOT SHOWN)	1
49	107343-001	DECAL - ELECTRICAL GROUNDING INST'S (NOT SHOWN)	1
50	107243-001	DECAL - OPERATING INSTRUCTIONS (NOT SHOWN)	1
51	106985-001	DECAL - RATING PLATE, I.D. & SERIAL # (NOT SHOWN)	1
52	110290-001	DECAL - WARNING, UNIT USAGE (NOT SHOWN)	1
53	107870-001	DECAL - CERTIFIED AIR DELIVERY, (NOT SHOWN)	1
54	100121-009	WASHER - LOCK, 1/4", HELICAL SPG, PLATED	1
55	119230-001	DECAL - "NOTE: THIS HEATER HAS A 4-SEC..." (NOT SHOWN)	1
56	111837-001	DECAL - DIRECTIONAL ARROW, BLACK	2
57	107064-001	FITTING - COUPLING, ANCHOR, 1/4" FNPT, 3/4"-16 ANCHOR	3
58	107059-001	FITTING - ELL, STREET, 90°, LOW PROFILE, 1/4" NPT, BRASS	2
59	107609-001	FITTING - 1/4" NPT X 1/4" TUBE, 90° FEMALE	1

**Table 3.1a: #1590**  
Parts List (continued)

### 3.1 Parts Diagram & List (continued)

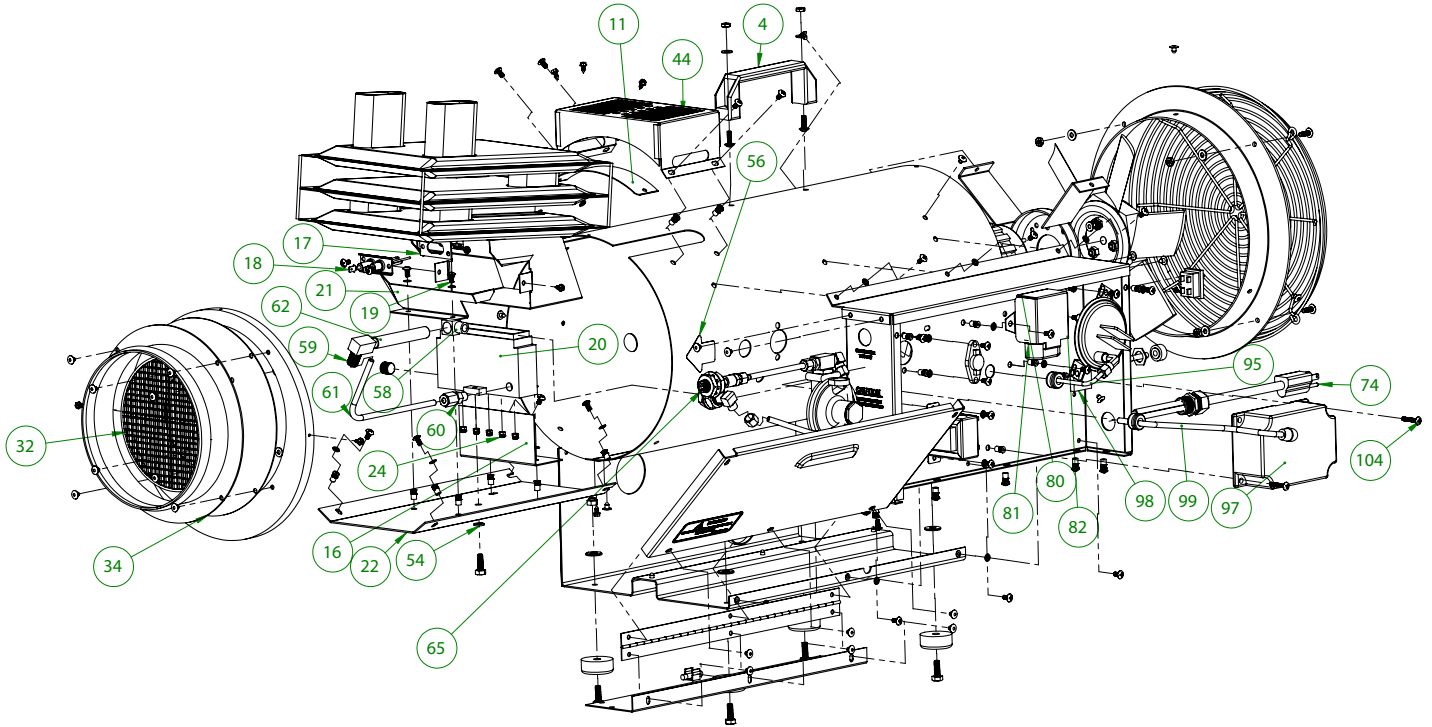

**Figure 3.1b: #1590**  
Parts Diagram

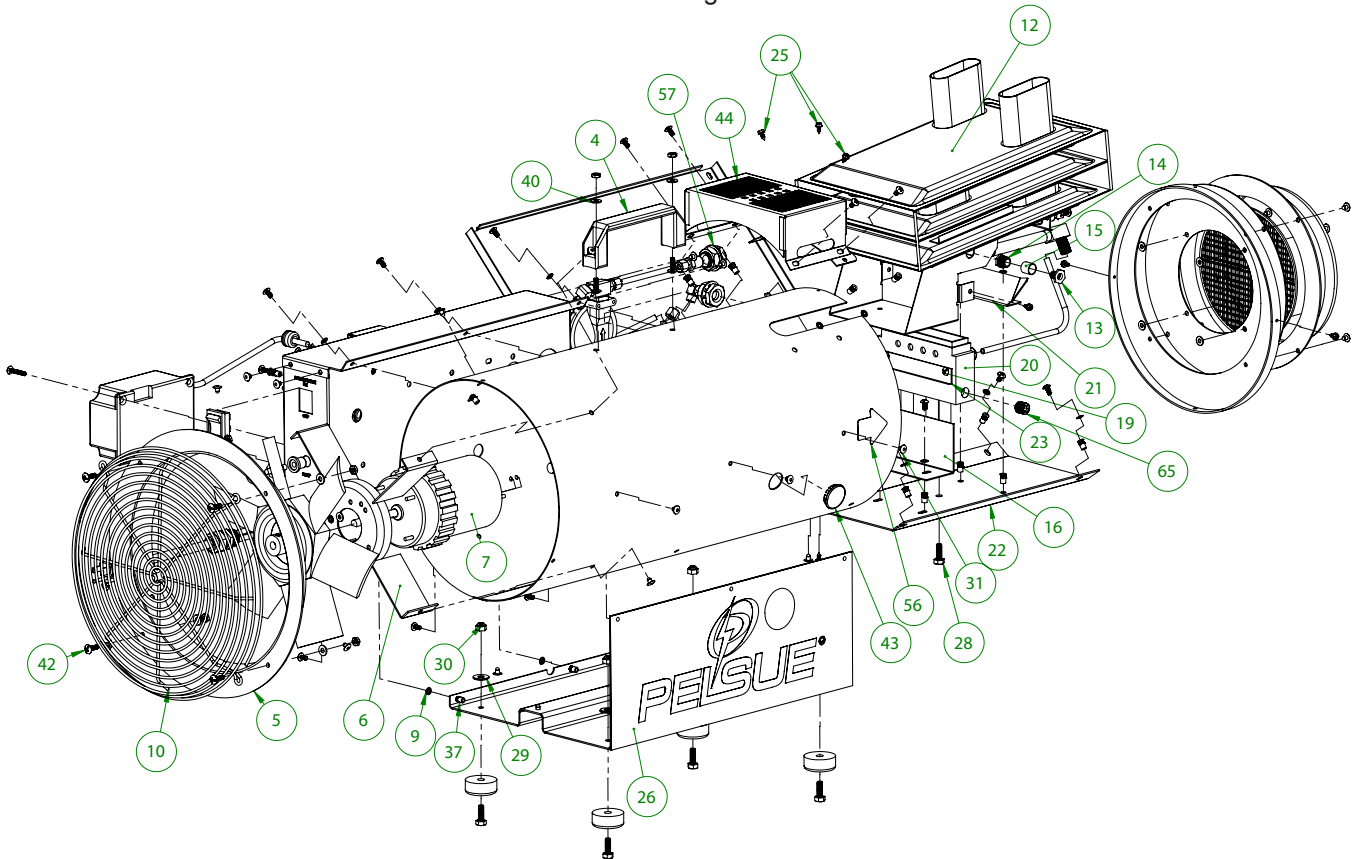

**Figure 3.1c: #1590**  
Parts Diagram

### 3.1 Parts Diagram & List (continued)

ITEM NUMBER	PART NUMBER	DESCRIPTION	QUANTITY
60	107069-001	FITTING - MALE CONN. 1/4" OD TUBE COMP. X 1/8" MNPT	1
61	107108-001	FUEL LINE - S.S. TUBE, .250" OD X .035" WALL, 9.50" LG	1
62	32F-013600	FITTING - NIPPLE 1/4" MNPT X 3.50" LONG, STEEL	1
63	107065-001	FITTING - COMP. ELL, 1/4" OD TUBE X 1/4" MNPT, BRASS	2
64	118461-001	FITTING - NUT, COMPRESSION, FOR 1/4" TUBING, 7/16"-24	3
65	107067-001	FITTING - PIPE PLUG, 1/4" MNPT, COUNTERSUNK HEX HD	2
66	107672-001	BRACKET - PITOT TUBE SUPPORT, AIR PRESSURE SWITCH	1
67	106980-001	TOP PANEL - CONTROL BOX	1
68	106981-001	BOTTOM PANEL - CONTROL BOX, ALUMINUM	1
69	106979-001	MOUNTING PANEL - CONTROL BOX	1
70	107056-001	FUSE CLIP - TYPE 101002, FOR MOUNTING 3A FUSES	1
71	107102-001	HINGE - PIANO WIRE, CONTROL BOX DOOR	1
72	106982-001	DOOR - CONTROL BOX	1
73	100405-004	STRAIN REL - 1/2" HUB, 0.250"- 0.375" DIAMETER	1
74	26E-005700	CORDSET - W/MOLDED PLUG 16/3 SJTOW RATED	1
75	107336-001-03	WASHER - FUSE HOLDER, HEX HEAD	1
76 & 77	107336-001-01	FUSE HOLDER - MALE SPADE TERMINAL, FEMALE RECEPT.	1
78	100097-006	FUSE - 1 AMP 1/4" X 1-1/4", GLASS TUBE	2
79	120959-001	SWITCH - ROCKER, SPST, 125/250 VAC 20A, 14VDC 14A	1
80	110007-001	CAPACITOR - 7.5 MFD, 370 VAC, 60 HZ	1
81	110288-001	COVER - RUBBER, CAPACITOR CONNECTION	1
82	114628-001	CAPACITOR BRACKET	1
83	107602-001	SWITCH - THERMAL CUT OFF, OPEN @ 120, CLOSE @ 110	1
84	107076-001	FITTING - MALE, 1/4" MNPT X 1/4" COMPRESSION, BRASS	4
85	107275-001	TUBE - COPPER, 1/4" OD X 4.75" LONG	1
86	107062-001	FITTING - TEE, 1/4" FNPT X 1/4" FNPT X 1/4" MNPT	1
87	107061-001	FITTING - REDUCER BUSHING, 3/8" MNPT X 1/4" FNPT	1
88	107104-001	TUBE - COPPER, .250" O.D. X 11.50" LONG	1
89	35G-010100	REGULATOR - PROPANE RATED TO 11" W.C.	1
90	32F-151500	FITTING - NIPPLE, CLOSE, 1/4" MNPT X .88" LONG BRASS	1
91	26E-041400	VALVE - SOLENOID, MAGNETIC, 24VAC	1
92	107106-001	TUBE - COPPER, .25" OD X 3.00" LONG	1
93	103768-001	SWITCH - AIR PRESSURE, 480 VAC, SET TO .55" N/ OPEN	1
94	107066-001	FITTING - 90° ELBOW, 3/16" OD TUBE X 1/8" MNPT	1
95	107107-001	TUBE - COPPER, .187" OD X 7.00" LONG	1
96	26E-002801	TRANSFORMER - 25VA, 115/230 INPUT, 24VAC OUTPUT	1
97	117524-001	CIRCUIT BOARD - GAS IGNITER CONTROL, 24VAC	1
98	26E-041310	CABLE ASSY - (CIRCUIT BOARD), W/ 18GA, WIRES	1
99	111519-001	LEAD - HIGH TENSION, ASSEMBLY	1
100-103	107-038/426/427	DECALS (NOT SHOWN)	1
104	111844-010	SCREW - MACHINE, TRUSS HD, #8-32 X 1" LONG, BLACK	2
105	32F-154200	FITTING - ADAPTER, 9/16" L.H. W/ INV. FLARE X 1/4" MNPT	1
106	109264-001	CAP - DUST, YELLOW RUBBER W/ RETAINER, 1/2" I.D.	1
107	101040-003	RIVET - STAVEX, BLIND FLANGE DOME, BLACK, .188" DIA	1
108	62E-011200	GROMMET - RUBBER, 3/8" ID X 3/4" OD	2

**Table 3.1a:** #1590  
Parts List (continued)

## 3.2 - Wiring Diagram

---

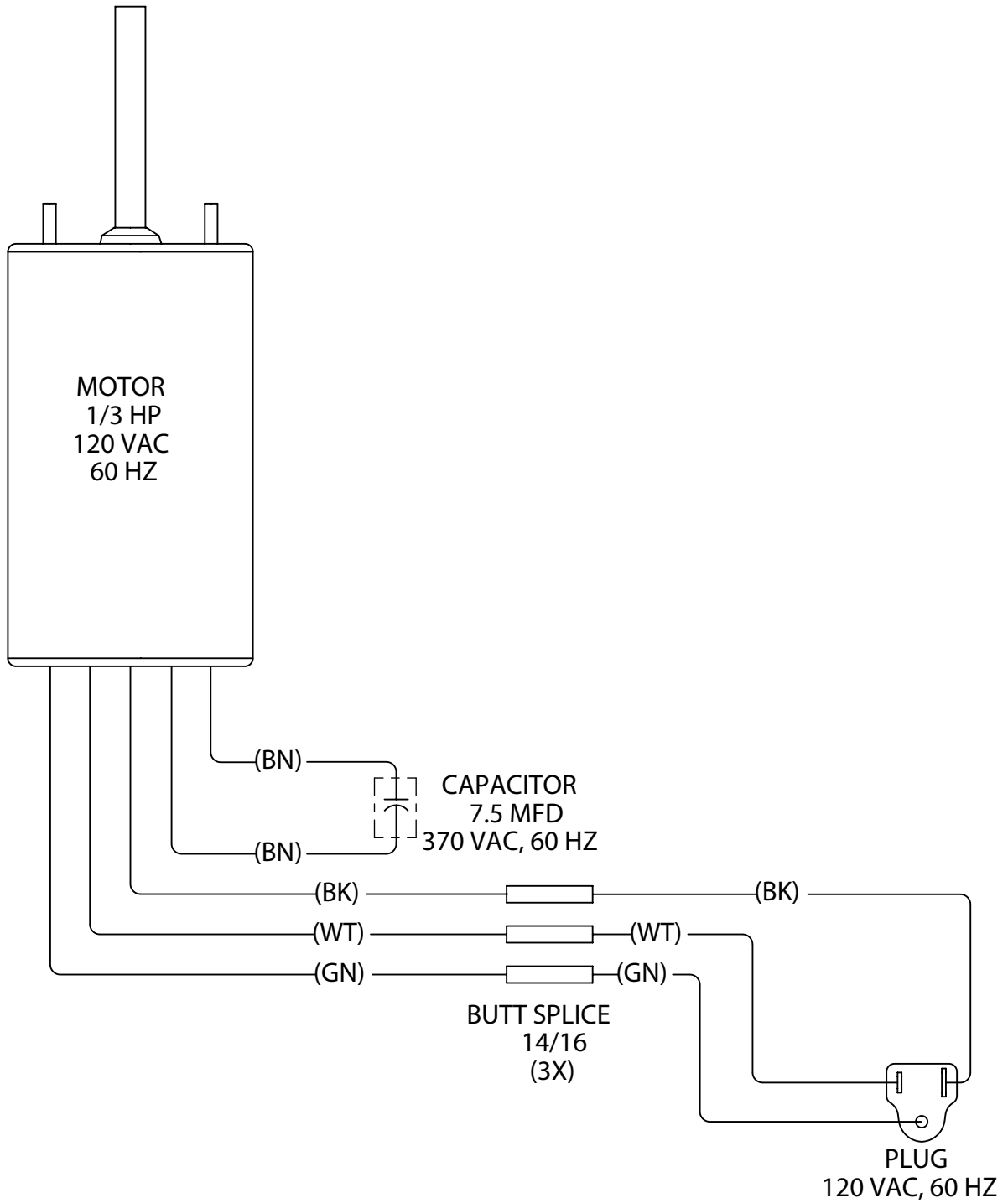

**Figure 3.2a:** #1590 Motor  
Wiring Diagram

The following section will address the safety precautions which must be adhered to when working with the Pelsue Construction Heater. Any user must familiarize themselves with the information in this section before utilizing the equipment.

### SIGNAL WORDS:

Note the use of the signal words **DANGER**, **WARNING** and **CAUTION** with the safety messages. The appropriate signal word for each message has been selected using the following guidelines:

- DANGER-** Indicates an imminently hazardous situation that, if not avoided, will result in death or serious injury. This signal word is to be limited to the most extreme situations or for hidden or unseen hazards.
- WARNING-** Indicates a potentially hazardous situation that, if not avoided, could result in death or serious injury and includes obvious and hidden hazards. It may also be used to alert against unsafe practices.
- CAUTION-** Indicates a potentially hazardous situation that, if not avoided, may result in minor or moderate injury. It may also be used to alert against unsafe practices.

You are responsible for the safe operation of your Pelsue Construction Heater. You must ensure that anyone who will operate or work around the equipment be familiar with it and general safety practices when working around gases. This manual will take you step-by-step through the workings and capabilities of the #1590 Construction Heater and alert you to good safety and operating practices while using the system.

Remember, you are the key to safety. Good safety practices not only protect you but also the people around you. Make these practices a working part of your safety program. Do not risk injury or death by ignoring good safety practices.

- The most important safety device on this equipment is a safe operator. It is the operator's responsibility to read and understand all of the safety and operating instructions in the manual and to follow them. Most accidents can be avoided.
- A person must understand the operation of this equipment and be trained in its usage before operating the equipment. An untrained operator exposes himself and others to possible serious injury or death.
- Do not modify the equipment in any way. Unauthorized modification may impair the function and/or safety and could affect the life of the equipment.
- Think SAFETY! Work SAFELY! **! CAUTION !** - The heater is not recommended for home or recreational vehicle use. The heater should not be used in aerial bucket truck.



**! CAUTION !** - Do not use heater in a space where gasoline or other liquids having flammable vapors are present.

**! CAUTION !** - Heater produces heated ventilation from an open flame. Keep solid combustibles, such as building materials, paper or cardboard, a safe distance away from the heater as recommended. Never use the heater in spaces which may contain volatile or airborne combustibles, dust particles, paint, thinner, solvents or unknown chemicals.

### 4.1 - Safety Alert Symbol

#### SAFETY ALERT SYMBOL

This Safety Alert symbol means **ATTENTION! BECOME ALERT! YOUR SAFETY IS INVOLVED!**

The Safety Alert symbol identifies important safety messages on your Pelsue Confined Space Product and in the manual. When you see this symbol, be alert to the possibility of personal injury or death. Follow the instruction in the safety message.

Why is this symbol important to you?

- 3 BIG Reasons:**
- Accidents Disable and Kill.**
  - Accidents Cost You Money.**
  - Accidents Can Be Avoided.**



## 4.2 - General Safety Information

### Safety Precautions:

It is necessary to follow these safety precautions, each time, prior to using the product.

The Safety Precautions are not limited to, but must include the following items;

1. Do not use the heater / blower for anything other than its intended use.
2. This heater is designed to function with a two-stage regulator system. A first stage regulator is required at the bottle, dropping the gas pressure down to 10-35 psi (pounds per square inch). The regulator built into the unit then drops the hose pressure further to 10" WC (water column) for use within the heater.
3. Make sure all L.P. fittings are tight. Only a pipe joint compound that is resistant to liquified petroleum gases should be used.
4. The propane bottle must be a vapor draw style, DOT (for U.S.) or CTC (for Canada) approved, 20 or 40 lbs gas cylinder. Do not use a forklift or liquid withdrawal cylinder. Use only LPG (propane) fuel.
5. Propane gas is very flammable. Propane is scented such that its strong odor is readily detectable. If a gas odor is detected at any time, do not operate or continue to operate the unit until the source of the gas odor has been located. In the event of a leak, propane is heavier than air and will accumulate in low areas. **Never strike a match, create a spark or flame when you smell gas.** Move the heater outside and ventilate the area. Find and correct the source of the leak before attempting to light the heater. If the leak cannot be corrected, do not tamper with the heater. Turn the heater off and consult the manufacturer or a qualified technician.
6. **Do not lean over the heater during ignition or operation;** do not wear loose clothing that can become entangled in operating machinery. Do not operate the heater / blower without inlet and outlet screen guards in place. Do not place fingers or any other object through inlet or outlet screens.
7. Do not move, handle or service the unit while hot or burning. Permanent skin tissue damage can occur if contact is made with the unit. Let the heater cool down after it has been shut off.
8. Never direct this construction heater toward any LP gas cylinder within 20ft. The heater must be a minimum of six feet from any LP Gas cylinder. Keep away from fabric or combustibles. **Refer to clearance table below for distances.** Survey the work area for an potential hazards and correct them before operating the heater.
9. Unit should be used in a well ventilated area. When heater is in use, a positive air displacement of at least 4-CFM per 1,000 BTUH of the heater's rated output should be provided. The #1590 is rated at 45,000 BTU's, thus the flow must maintain a volumetric rate of at least 180 CFM (the #1590 is rated at 432 CFM in a free air configuration).
10. Always operate the heater / blower from a properly grounded receptacle.
11. Never handle energized power cords with wet hands. Never let extension cords or plug connections lay in water. Locate the heater / blower so that it cannot fall into water inadvertently.
12. Never use cords with frayed, cut, or brittle insulation. Check the cord for sound connections to the ground fault interrupter receptacle.
13. Never use the heater / blower in an explosive environment.
14. Ensure that toxic fumes are not blown into a confined space.
15. Unattended use of equipment is not recommended.
16. Heater should be inspected before each use and at least annually by a qualified service agency.

### **Heater Clearance**

<b>Sides:</b>	<b>24"</b>
<b>Inlet (Rear):</b>	<b>24"</b>
<b>Above:</b>	<b>60"</b>
<b>Outlet (no hose):</b>	<b>60"</b>
<b>Outlet (with hose):</b>	<b>24"</b>

# 5.0 - Product Operation

The following section will address the capabilities and the general operation of the Pelsue Model #1590 Axial Construction Heater / Blower. The instructions contained within this section should be adhered to each and every time the product is used. Any person tasked with installing or operating this piece of equipment should be familiar with these procedures.

## 5.1 - Product Description & Capabilities

The Pelsue Model #1590 Construction Heater is built from a rugged lightweight aluminum housing and base. The Pelsue #1590 Construction Heater is specifically designed to provide means of heating confined shelters or work areas. All specifications, instructions, and procedures provided within this manual or upon Pelsue Specification Documents are based upon and only valid for usage with Pelsue accessories. The T.A. Pelsue Company cannot verify equipment safety and/or compliance when utilized with anything other than Pelsue approved confined space accessories.

### Heater / Blower - #1590

#### General Specifications

- Weight - 35.0 lbs.
- Height - 14.0"
- Width - 14.5"
- Length - 27.0"
- BTU output - 45,000
- Free air output - 432 cfm

#### Features:

- Low Maintenance
- Automatic ignition system with gas lock-out in the event of loss of flame, can be reset manually
- Equipped with a certified safety control & flame sensor
- Thermal and pressure switches prevent operation if inlet or outlet are blocked

#### Materials & Construction

- Aluminum Base & Housing
- Stainless Steel Heat Exchanger
- Stainless Steel, Brass, & Copper Plumbing

#### Additional Requirements & Notes

- This heater is only intended for use in a well-ventilated space and is not for home or recreational vehicle use.

## 5.2 - Start-Up & Operating Procedures

Prior to Operation, the #1590 Construction Heater should be configured and prepared according to the following guidelines.

### 1. Pre-Operation Inspection:

It is necessary to perform a visual inspection, each time, prior to using the product. If deficiencies are found, remove the product from service and contact the T.A. Pelsue Company regarding repair. The following checklist coupled with *Figure #5.2a* should be used as a guide to determine whether the equipment is in good operating condition prior to usage. Equipment that is not in good condition can endanger the safety of the entrant and attendant during use.

The Pre-Operation Visual Inspection is not limited to, but must include the following items:

- Check that the heater / blower's inlet and outlet guards, as well as chimney screen are present and free of obstructions.
- Remove any objects or combustibles around the immediate area that could come into contact with or ignite from use of the heater.
- The cordset is properly attached to the heater / blower; the on/off switch is working properly, and set to "off".
- The rubber feet are attached.
- There are no kinks or breaks in the copper piping, and no leaks in the plumbing.
- The hose assembly is in good working condition, with no cuts or knicks present.

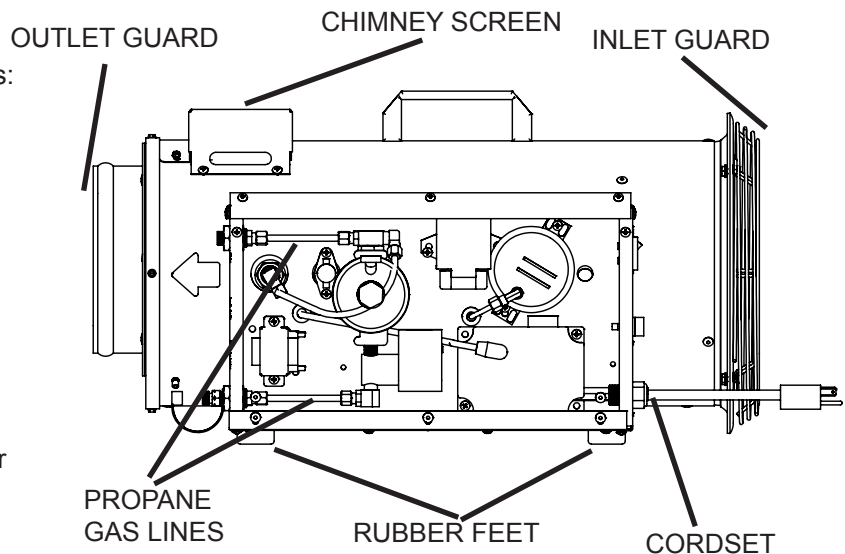

**Figure #5.2a:** #1590 Pre-Inspection Points

## 5.2 - Start-Up & Operating Procedures (continued)

### 2. Operation of 1590 Construction Heater:

Choose a location where installation will provide suitable proximity to the work area yet minimize obstructions during use and in the event a rescue is necessary. Once a location is chosen:

- a. Inspect the control box fuel lines, fuel inlet, and base for signs of liquid fuel or oil contamination. If present, DO NOT USE THE HEATER. Have a qualified technician disassemble the LPG supply line and components to remove the liquid fuel or oil before use of the heater.
- b. Place the heater on a secure and level surface. The heater must be positioned such that it is not directly exposed to wind, water, spray, rain, and/or dripping water.
- c. Connect the LPG supply hose with the first stage regulator assembly to a 20 or 40 lb approved cylinder. (First stage regulator should take bottle pressure down to 10 - 35 psi). Connect the hose to the heater and tighten all connections. Locate the LPG gas cylinder as least 6 ft away from the heater in a position away from the direct path of heated flow from the blower.
- d. Turn on the fuel at the LPG cylinder and recheck all fittings for possible leaks using a soap solution. Tighten any leaks found and retest. Never use a match to check for leaks. NOTE: The longer the fuel hose length, the longer period of time to purge the hose of air from the initial hookup.
- e. **IGNITION:** (DO NOT STAND OVER THE HEATER OR LEAN OVER THE CHIMNEY) Turn heater control switch to the "on" position. There will be a 4 second delay prior to ignition once the switch has been turned on, to facilitate a safety purge of the combustion chamber. After this delay the pilot should be lit, and the heater should fire.
- f. Connect a Pelsue heat-resistant blower hose to the heater outlet, in order to direct fresh, heated air to desired location. Ensure that NO toxic fumes are blown into an unventilated area.
- g. **TO TURN HEATER OFF:** First turn off the fuel supply at the LPG bottle. This burns off any excess fuel in the supply hose and lowers the line pressure. When the heater flame goes out (lack of combustion noise will be evident) turn the control switch to "off". Leave the heater / blower plugged in to an electrical receptacle, so the blower continues to run for at least 5 minutes, to cool the heat exchanger. Disconnect the hose from the propane bottle to the heater. Check for leakage. Once cool, disconnect power and remove the blower hose.
- j. NOTE: The hose assembly shall be visually inspected prior to each use. If it is evident that there is excessive abrasion or wear, or the hose is cut, it must be replaced prior to heater operation. The replacement hose assembly must be that specified by the manufacturer.

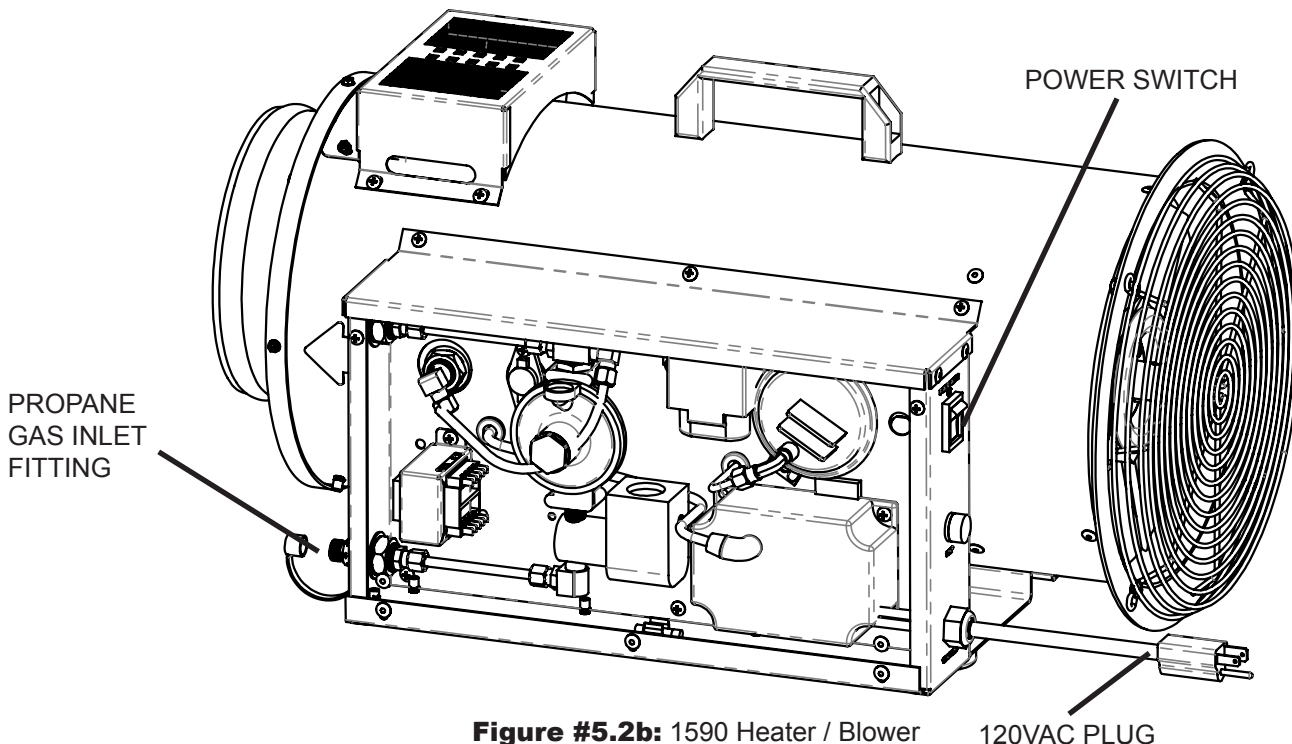

**Figure #5.2b:** 1590 Heater / Blower Controls

120VAC PLUG



## 5.2 - Start-Up & Operating Procedures (continued)

### Important Notes:

- During confined space entry operations, it should not be assumed that the heater/blower will maintain the air inside the confined space at a safe condition. When the ventilator is in use, the air inside the confined space should be monitored continuously for the presence of poisonous gases and/or toxic fumes.
- Ensure that the blower provides positive airflow the entire time during usage. The blower can be used with an accessory Pelsue Air Flow Alarm (#123717-001) in order to alert the entrants if positive ventilation is lost
- As shown in Figure #5.2c below, the heater should be placed at least 1.5 meters (approximately 5 feet) upwind of the confined space point of entry, in order to ensure that any contaminants are not directed toward the heater inlet.

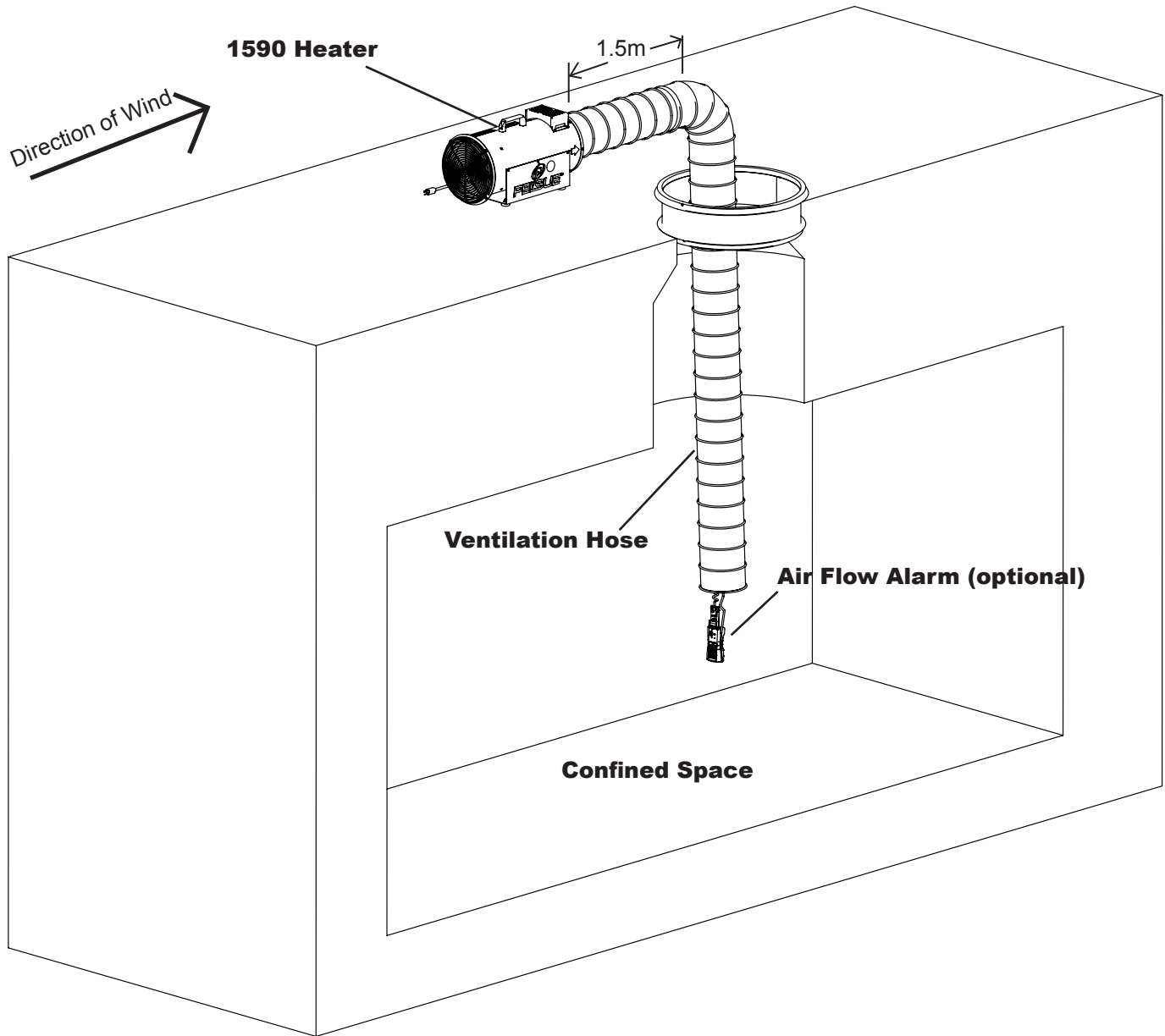

**Figure #5.2c:** 1590 Heater / Blower Setup for Confined Spaces

## 6.0 - Troubleshooting

<b>SYMPTOM</b>	<b>CAUSE</b>	<b>REMEDY</b>
Gas will not ignite when burner is turned on and spark is present	<ol style="list-style-type: none"> <li>1. LPG bottle is empty</li> <li>2. Faulty solenoid valve</li> <li>3. Faulty regulator</li> <li>4. LPG cylinder valve is shut</li> <li>5. Obstruction of heater outlet</li> <li>6. Fuel pressure to manifold is too low</li> </ol>	<ol style="list-style-type: none"> <li>1. Fill LPG cylinder</li> <li>2. Replace solenoid valve</li> <li>3. Replace regulator</li> <li>4. Open valve to "on" position</li> <li>5. Remove blockage</li> <li>6. Reset pressure to manifold to 10" W.C.</li> </ol>
Erratic flame at burner	<ol style="list-style-type: none"> <li>1. Orifice(s) loose or dirty</li> <li>2. Loose connections in fuel line plumbing</li> </ol>	<ol style="list-style-type: none"> <li>1. Tighten and / or clean orifice(s)</li> <li>2. Check and tighten connections leading to the burner box</li> </ol>
Flame will not go out when burner is switched off.	<ol style="list-style-type: none"> <li>1. Faulty or dirty solenoid valve</li> <li>2. Circuit board failure</li> </ol>	<ol style="list-style-type: none"> <li>1. Clean or replace solenoid valve</li> <li>2. Replace circuit board</li> </ol>
No spark when control switch is turned on	<ol style="list-style-type: none"> <li>1. Circuit board has locked out system for safety reasons</li> <li>2. Circuit board failure</li> <li>3. Pressure switch faulty or "off"</li> </ol>	<ol style="list-style-type: none"> <li>1. Re-cycle the heater ignition system by turning "off" power switch for 30 seconds</li> <li>2. Replace circuit board</li> <li>3. Check to be sure blower is on, otherwise replace pressure switch</li> </ol>
Burner lights for 3-4 seconds, and then shuts off	<ol style="list-style-type: none"> <li>1. Circuit board failure</li> <li>2. Flame sensor failure</li> </ol>	<ol style="list-style-type: none"> <li>1. Replace circuit board</li> <li>2. Replace flame sensor / spark igniter unit</li> </ol>
Yellow flame	<ol style="list-style-type: none"> <li>1. Dirty orifice(s)</li> </ol>	<ol style="list-style-type: none"> <li>1. Clean orifices</li> </ol>

## 7.0 - Storage

Prior to storage, the heater should be thoroughly inspected and maintained. Repair or replace any worn or damaged components to prevent any unnecessary down time at the next use.

Follow this procedure:

1. Visually inspect daily for oil or liquid fuel contaminant present in the heater or fuel supply hose. If any is evident, heater should be cleaned and / or repaired by a qualified technician before use.
2. If the heater has not been in service for a long period of time, the following procedure should be initiated before placing it back into operation. Use an air hose (not to exceed 30 psi) to blow off any dust/dirt that has accumulated on the heater. Pass the air hose over the chimney, inlet, and outlet. (Vacuuming is acceptable)
3. Wipe the housing clean using a soap and water solution or a nonabrasive aluminum cleaner.
4. If a malfunction in the pressure regulator or safety shut-off control valve is found after placing the heater into operation, consult the factory or an experienced heating contractor for repair or replacement.

**For More Information...**



**T.A. Pelsue Company  
2500 S. Tejon St.  
Englewood, CO 80110**

**Toll Free: 1-800-525-8460  
Telephone: 1-303-936-7432  
Fax: 1-303-934-5581**

**Website: [www.pelsue.com](http://www.pelsue.com)**

**Email: [sales@pelsue.com](mailto:sales@pelsue.com)**



**T.A. Pelsue Company**

2500 South Tejon Street, Englewood, Colorado, USA 80110  
Toll free 800-525-8460 or 303-936-7432 Fax. 303-934-5581  
Internet: [www.pelsue.com](http://www.pelsue.com) Email: [sales@pelsue.com](mailto:sales@pelsue.com)