

REVISION HISTORY		
REV.	DESCRIPTION	DATE
01	PRELIMINARY RELEASE PER EP0168	2022-01-23
A	INITIAL RELEASE PER EP0168	2022-01-24

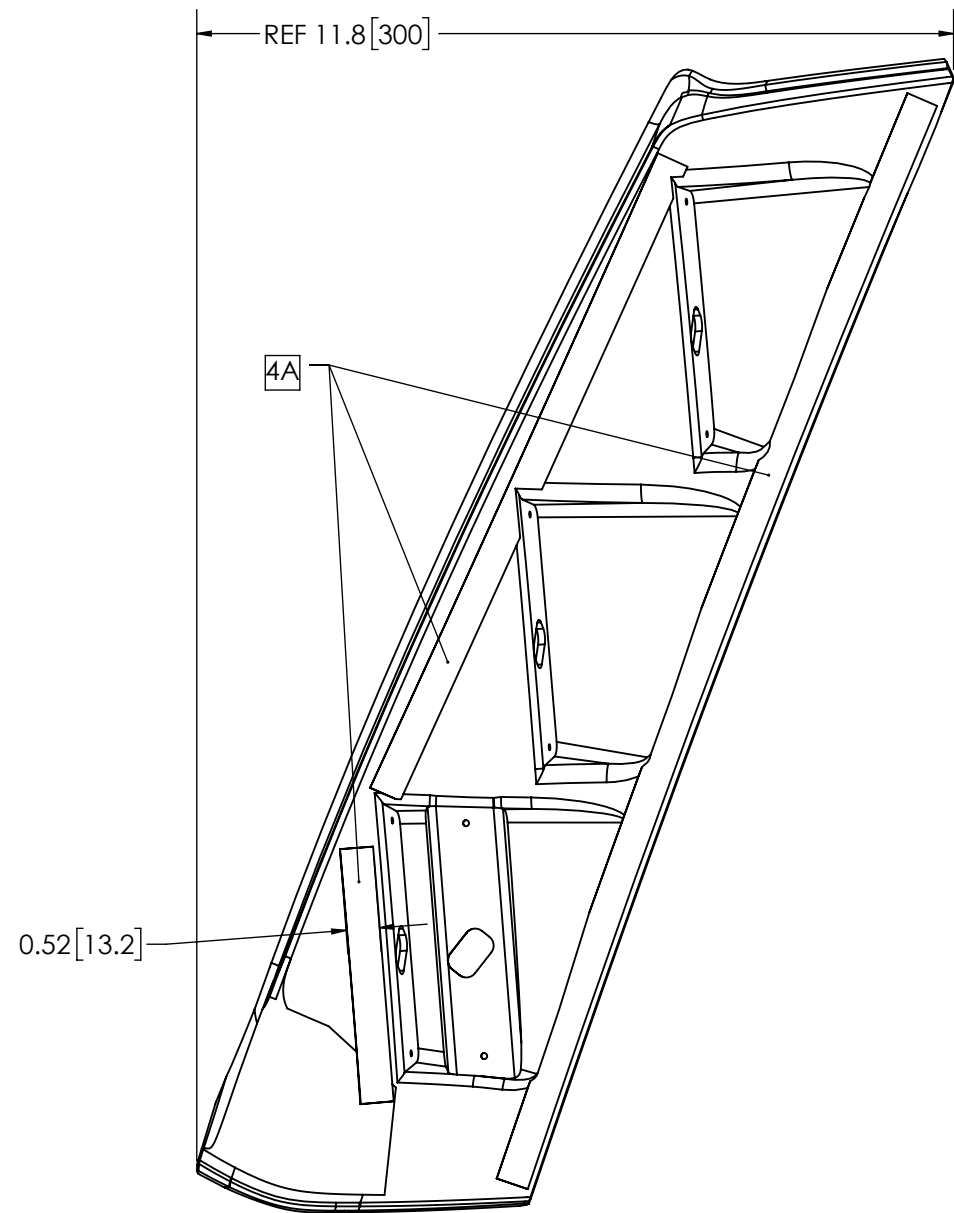

BACK VIEW

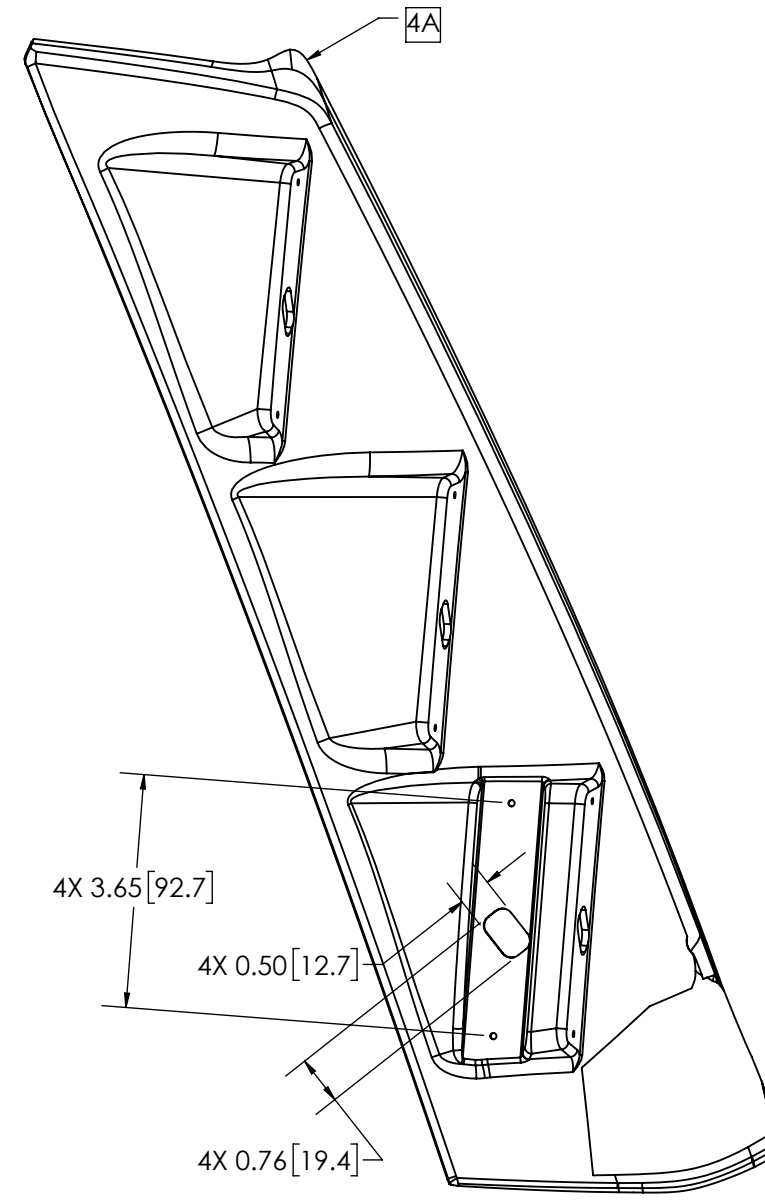

FRONT VIEW

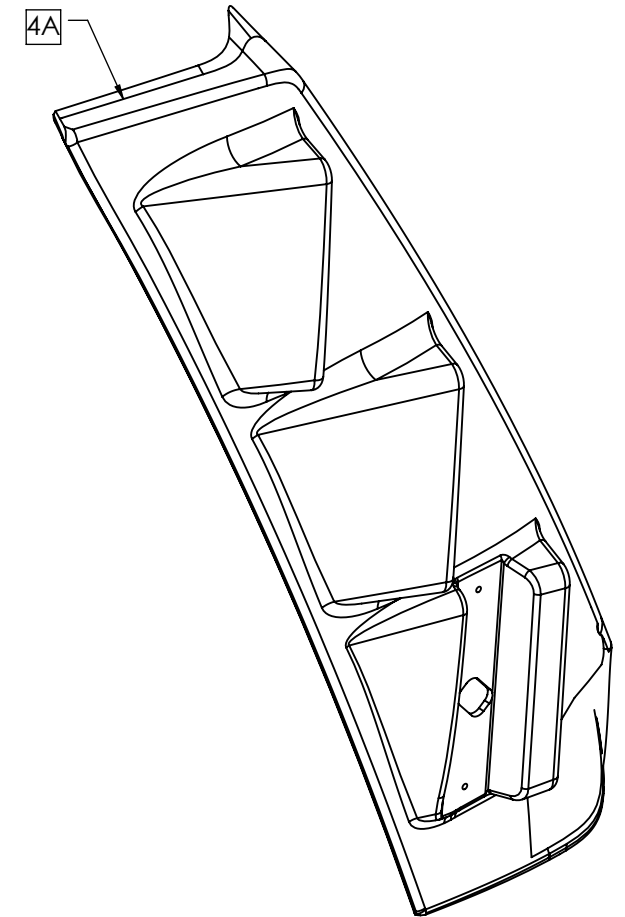

ISOMETRIC VIEW

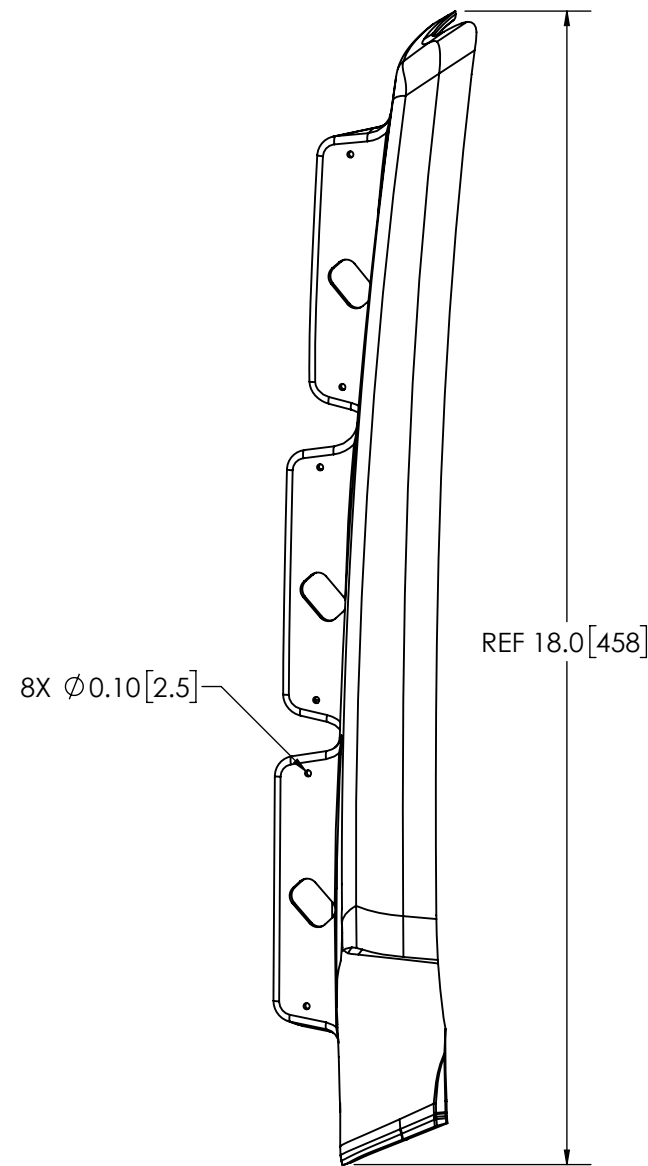

SIDE VIEW

NOTES:

1. THE SOLID MODEL PROVIDED BY ESG IS TO BE USED FOR TOOLING DESIGN. INSPECTION WILL INCLUDE, BUT NOT BE LIMITED TO, THE DIMENSIONS ON THIS DRAWING.
2. MATERIAL: SEE RD-0026-00 OR POLYCARBONATE SABIC LS-2 OR EQUIVALENT
3. COLOR: BLACK
4. SURFACE FINISH:
 [A] SPI A-2 OR FINER ON ALL EXTERNAL SURFACES AND WHERE NOTED
 B. SPI D-3 OR FINER ON ALL INTERNAL SURFACES
5. EJECTOR PIN MARKS ONLY ALLOWED ON BOTTOM INTERNAL SURFACES AND MUST BE FLUSH OR RECESSED
6. GATING MARK SHOULD BE FLUSH OR RECESSED
7. ALL FEATURES DEFINED WITHIN THE SOLID MODEL & DIMENSIONS IN THIS DRAWING ARE AFTER PART HAS COOLED & STABILIZED
8. NO FLASHING OR BURRS ARE ALLOWED
9. PARTS SHALL BE CLEAN & FREE OF ALL FOREIGN MATERIAL
10. DIMENSIONS IN INCHES[MILLIMETERS (FOR REFERENCE)]

SCALE 1:3		APPROVALS	DATE
CAD GENERATED DRAWING FROM SOLID MODEL: REV. B DO NOT MANUALLY UPDATE.		DRAWN BY NMT	2022-01-24
TOLERANCES ARE IN INCHES AND MILLIMETERS TOLERANCES UNLESS OTHERWISE STATED ARE:		CHECKED BTK	2022-01-24
MILLIMETERS DECIMALS		MECH. ENG. NMT	2022-01-24
0.25	0.5	ELEC. ENG.	
0.5	0.7	MFG. ENG. TMP	2022-01-24
0.7	1.0	TEST ENG.	
1.0	2.0		
2.0	3.0		
3.0	6.0		
6.0	0.0030		
INCHES DECIMALS	ANGLES		
X ± .1	± 0.5°		
XX ± .01	FRACTIONS		
XXX ± .005	± 1/64		
XXXX ± .0030			



United States
1-800-635-5900
Americas@eccogroup.com
United Kingdom
+44 (0)113 237 5340
Europe@eccogroup.com
Australia
+61 (0)3 63322444
AsiaPacific@eccogroup.com

HOUSING, DPILLAR, TH21, LEFT

PROPRIETARY AND CONFIDENTIAL INFORMATION
 THIS DRAWING AND THE DESIGN AND OTHER INFORMATION DISCLOSED HEREIN ARE THE PROPERTY OF ELECTRONIC CONTROLS COMPANY AND/OR ITS ECCO SAFETY GROUP AFFILIATES ("ESG") AND IS ISSUED IN CONFIDENCE TO RECIPIENT FOR ENGINEERING INFORMATION PURPOSES ONLY. THIS DRAWING AND THE DESIGN AND OTHER INFORMATION DISCLOSED HEREIN MAY NOT BE USED, COPIED, REPRODUCED OR OTHERWISE DISCLOSED IN PART OR IN WHOLE TO THIRD PARTIES OR USED FOR ANY OTHER PURPOSE WITHOUT PRIOR ESG WRITTEN CONSENT. ESG RESERVES ALL PATENT, COPYRIGHT, TRADEMARK AND OTHER PROPRIETARY RIGHTS TO THIS DOCUMENT, INCLUDING ALL DESIGN, MANUFACTURING, REPRODUCTION, USE AND SALES RIGHTS THERE TO. THIS DRAWING IS SUBJECT TO RECALL BY ESG AT ANY TIME, AND YOUR POSSESSION AND/OR USE CONSTITUTES ACCEPTANCE OF THESE TERMS. ©2021 ELECTRONIC CONTROLS COMPANY

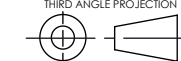

Electronically Controlled Use Latest Copy

SIZE: B	DWG. NO. 250-0709-00	REV. B
SHEET 1 OF 1	Project: EP0168	Date Created: 2021-12-07