

INSTALLATION & OPERATION MANUAL



ARCH™ Beacon

Contents:

- Introduction.....2
- Features and Specifications.....2
- Flash Patterns.....3-4
- Dimensions.....5
- Installation & Mounting.....5-7
- Wiring.....8
- Operation.....8
- Maintenance&Troubleshooting.....9
- Notes10-11
- Warranty.....12

IMPORTANT: Read all instructions and warnings before installing and using.
INSTALLER: This manual must be delivered to the end user of this equipment.

Introduction

The ARCH™ Beacon is a weatherproof LED based warning light that contains 36 state-of-the-art high intensity LEDs in three stacked rows. The unique design efficiently captures light from the LEDs with individual optics that diffuse the light in an effective warning pattern.

WARNING!



This Product contains high intensity LED devices. To prevent eye damage, DO NOT stare into light beam at close range.



WARNING!

The use of this or any warning device does not insure that all drivers can or will observe or react to an emergency warning signal. Never take the right-of-way for granted. It is your responsibility to be sure you can proceed safely before entering an intersection, driving against traffic, responding at a high rate of speed, or walking on or around traffic lanes.

The effectiveness of this warning device is highly dependent upon correct mounting and wiring. Read and follow the manufacturer's instructions before installing or using this device. The vehicle operator should insure daily that all features of the device operate correctly. In use, the vehicle operator should insure the projection of the warning signal is not blocked by vehicle components (i.e.: open trunks or compartment doors), people, vehicles, or other obstructions. This equipment is intended for use by authorized personnel only. It is the user's responsibility to understand and obey all laws regarding emergency warning devices. The user should check all applicable city, state and federal laws and regulations.

Code 3, Inc., assumes no liability for any loss resulting from the use of this warning device.

Proper installation is vital to the performance of this warning device and the safe operation of the emergency vehicle. It is important to recognize that the operator of the emergency vehicle is under psychological and physiological stress caused by the emergency situation. The warning device should be installed in such a manner as to: A) Not reduce the output performance of the system, B) Place the controls within convenient reach of the operator so that he can operate the system without losing eye contact with the roadway.

Emergency warning devices often require high electrical voltages and/or currents. Properly protect and use caution around live electrical connections. Grounding or shorting of electrical connections can cause high current arcing, which can cause personal injury and/or severe vehicle damage, including fire.

PROPER INSTALLATION COMBINED WITH OPERATOR TRAINING IN THE PROPER USE OF EMERGENCY WARNING DEVICES IS ESSENTIAL TO INSURE THE SAFETY OF EMERGENCY PERSONNEL AND THE PUBLIC.

Features and Specifications:

Operating Voltage: DC11V-16V, Reverse Polarity Protected

Operating Current: Avg 3.75 amps, Max 7.5 amps

Weight: 4.5 lb

Flash Modes Description:

- | | |
|--------------------------|--|
| 1. Cycle-Flash: | Cycles through Quad, Double, Triple, and Single modes. |
| 2. Quad-Flash: | Four consecutive pulses per flash. |
| 3. Triple-Flash: | Three consecutive pulses per flash. |
| 4. Double-Flash: | Two consecutive pulses per flash. |
| 5. Single-Flash: | Single pulse per flash. |
| 6. Variable Single-Flash | Single pulse per flash with varying flash rate. |

Please note that a beacon set with a PHASE 0 flash pattern will alternate with beacons set with a PHASE 1 pattern and flash simultaneously with beacons set with a PHASE 0 flash pattern.

Flash Patterns (including for those with scene lights):

PATTERN NO.	PATTERNS	SYNCHRONIZE
1	NFPA Quad Phase 0	YES
2	Cycle Flash 75fpm Phase 0	YES
3	Quad 75fpm Phase 0	YES
4	Triple 75fpm Phase 0	YES
5	Double 75fpm Phase 0	YES
6	Single 75fpm Phase 0	YES
7	Variable Single Flash Phase 0	YES
8	Rotate 75rpm	Simultaneous Only
9	NFPA Quad Phase 1	YES
10	Cycle Flash 75fpm Phase 1	YES
11	Quad 75fpm Phase 1	YES
12	Triple 75fpm Phase 1	YES
13	Double 75fpm Phase 1	YES
14	Single 75fpm Phase 1	YES
15	Variable Single Flash Phase 1	YES
16	Cycle Flash 150fpm Phase 0	YES
17	Quad 150fpm Phase 0	YES
18	Triple 150fpm Phase 0	YES
19	Double 150fpm Phase 0	YES
20	Single 150fpm Phase 0	YES
21	Single 250fpm Phase 0	YES
22	Single 375fpm Phase 0	YES
23	Rotate 150rpm	Simultaneous Only
24	Cycle Flash 150fpm Phase 1	YES
25	Quad 150fpm Phase 1	YES
26	Triple 150fpm Phase 1	YES
27	Double 150fpm Phase 1	YES
28	Single 150fpm Phase 1	YES
29	Single 250fpm Phase 1	YES
30	Single 375fpm Phase 1	YES
31	NFPA Quad Alternating	Simultaneous Only
32	Cycle Flash 75fpm Alternating	Simultaneous Only
33	Quad 75fpm Alternating	Simultaneous Only
34	Triple 75fpm Alternating	Simultaneous Only
35	Double 75fpm Alternating	Simultaneous Only
36	Single 75fpm Alternating	Simultaneous Only
37	Cycle Flash 150fpm Alternating	Simultaneous Only
38	Quad 150fpm Alternating	Simultaneous Only
39	Triple 150fpm Alternating	Simultaneous Only
40	Double 150fpm Alternating	Simultaneous Only
41	Single 150fpm Alternating	Simultaneous Only
42	Single 250fpm Alternating	Simultaneous Only
43	Single 375fpm Alternating	Simultaneous Only

Flash Patterns for ECE-65 compliant beacons:

PATTERN NO.	PATTERNS	SYNCHRONIZE
1	Single Flash 120fpm	Simultaneous Only
2	Double Flash 120fpm	Simultaneous Only
3	Triple Flash 120fpm	Simultaneous Only
4	Quad Flash 120fpm	Simultaneous Only
5	Quintuple Flash 120fpm	Simultaneous Only
6	Rotate 120rpm	Simultaneous Only

Flash Patterns for multi-color beacons:

PATTERN NO.	PATTERNS	SYNCHRONIZE
1	NFPA Quad	Simultaneous Only
2	Cycle Flash 75fpm	Simultaneous Only
3	Quad 75fpm	Simultaneous Only
4	Triple 75fpm	Simultaneous Only
5	Double 75fpm	Simultaneous Only
6	Single 75fpm	Simultaneous Only
7	Cycle Flash 150fpm	Simultaneous Only
8	Quad 150fpm	Simultaneous Only
9	Triple 150fpm	Simultaneous Only
10	Double 150fpm	Simultaneous Only
11	Single 150fpm	Simultaneous Only
12	Single 250fpm	Simultaneous Only
13	Single 375fpm	Simultaneous Only

Dimensionior

(Basic dimensionior)

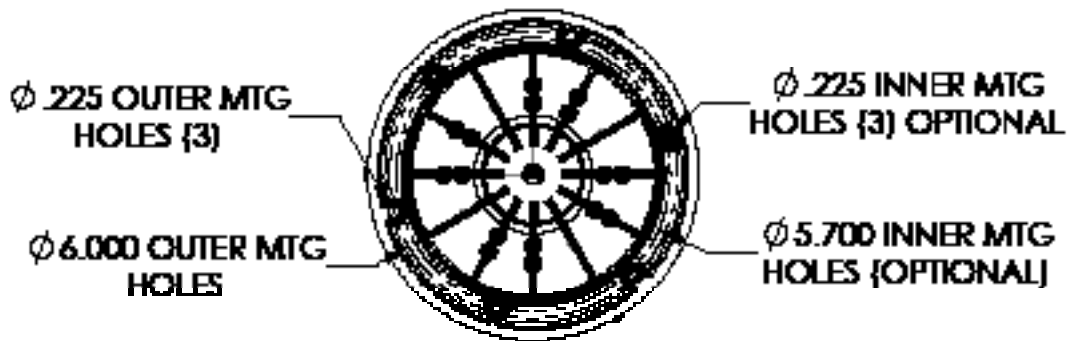
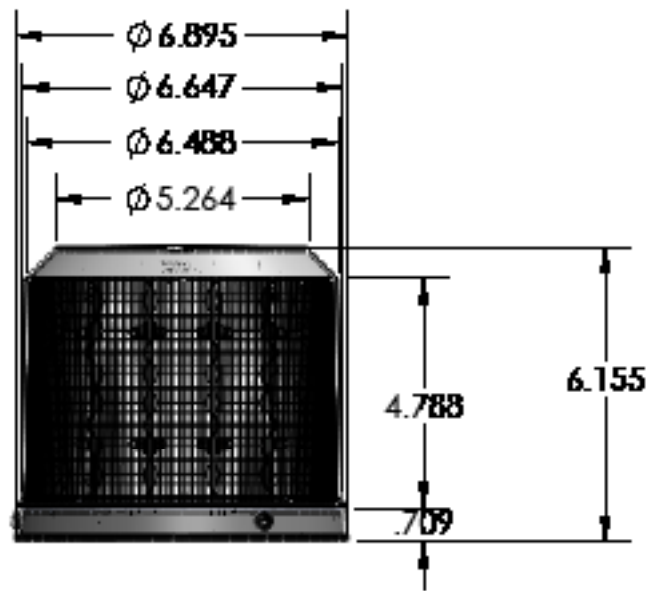

Standard Mounting Procedure:

1. Remove beacon outer lens.

Note: Two hole patterns are provided for the user. The standard 6 inch dia pattern and optional 5.7 inch dia pattern. Only three #10 fasteners are required to securely mount the beacon assembly.

2. Choose hole pattern (6" dia or 5.7" dia). Identify the 3 holes chosen as indicated on the base's label and punch out with a sharp object.

3. Use the beacon base to locate holes on mounting surface. Holes should accomodate a #10 fastener. A hole should be provided for wiring access at the center of the mounting area. The hole should be grommited and sealed with RTV around the wiring.

4. Align the gasket and and perimeter of the beacon base and punch out the 3 chosen mounting holes with a sharp object. Place gasket and beacon assembly on mounting surface being careful to align the mounting holes. Care should be taken to not pinch the wiring when placing the beacon assembly.

5. Install three #10 fasteners, flat washers with neoprene backing, and lock nuts (included) as shown to attach the assembly. Apply RTV to the fastener holes during the installation.

6. Reinstall beacon outer lens.

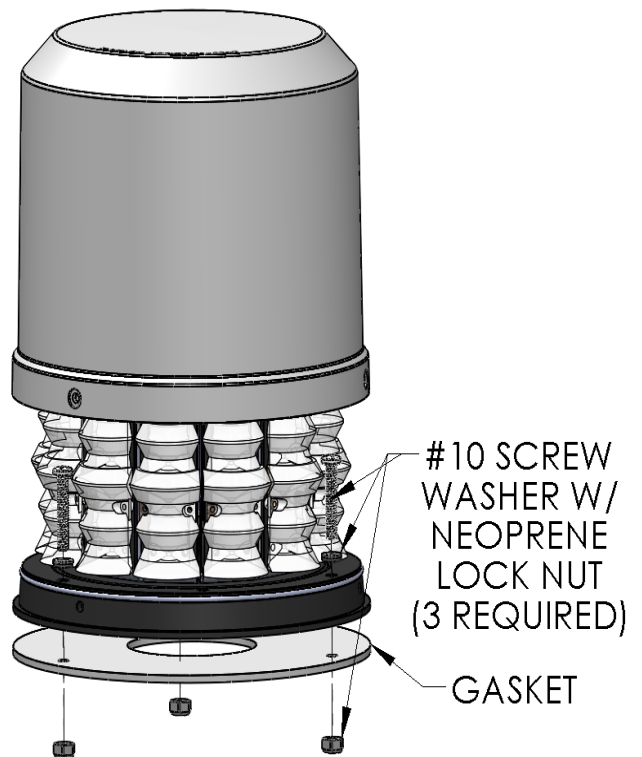

Optional 1in NPT Pipe Mount Assembly:

1. Remove beacon outer lens.
2. Choose the 6" dia hole pattern. Identify the 3 holes chosen as indicated on the base's label and punch out with a sharp object.
3. Align the base gasket and perimeter of the beacon base and punch out the 3 chosen mounting holes with a sharp punch. Place base gasket, adapter plate, pipe mount gasket, and pipe mount flange against base of beacon assembly.
4. Install three machine screws #10-24x1.5, flat washers with neoprene backing, and lock nuts (included) as shown to attach gasket and pipe mounting plate to beacon base.
5. Reinstall beacon outer lens.
6. Caution: do not thread pipe past depth of threads

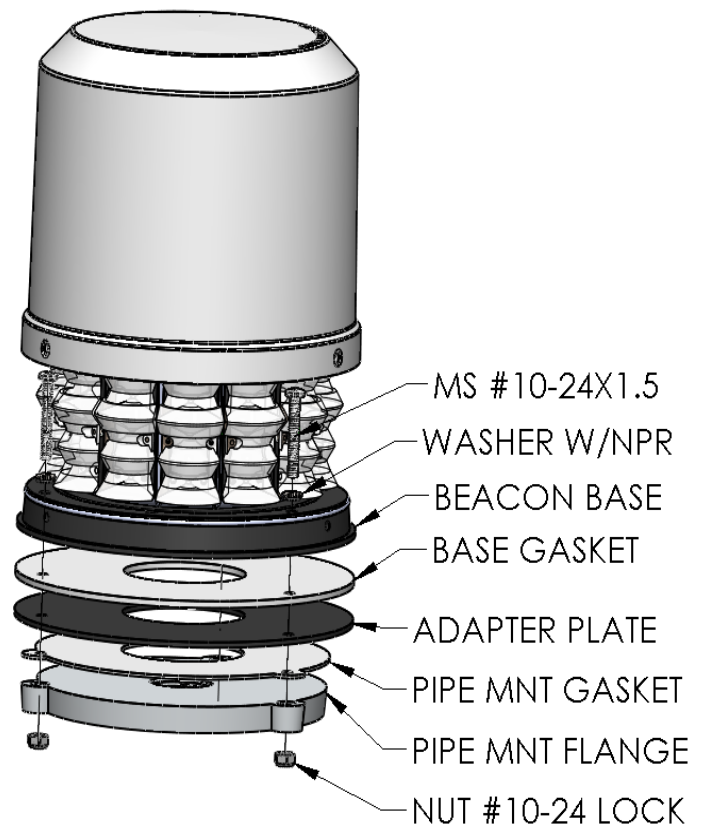

Optional Branch Guard Assembly:

1. Remove beacon outer lens.
2. Choose the 6" dia hole pattern. Identify the 3 holes chosen as indicated on the base's label and punch out with a sharp object.
3. Use the branch guard base to locate holes on mounting surface. Holes should accommodate a #10 fastener. A hole should be provided for wiring access at the center of the mounting area. The hole should be grommeted and sealed with RTV around the wiring.
4. Align the base gaskets and perimeter of the beacon base and punch out the 3 chosen mounting holes with a sharp object. Place base gasket, branch guard base, second base gasket, and beacon assembly on mounting surface being careful to align the mounting holes. Care should be taken to not pinch the wiring when placing the beacon assembly.
5. Install three #10 fasteners, flat washers with neoprene backing, and lock nuts (included) as shown to attach the assembly. Apply RTV to the fastener holes during the installation.

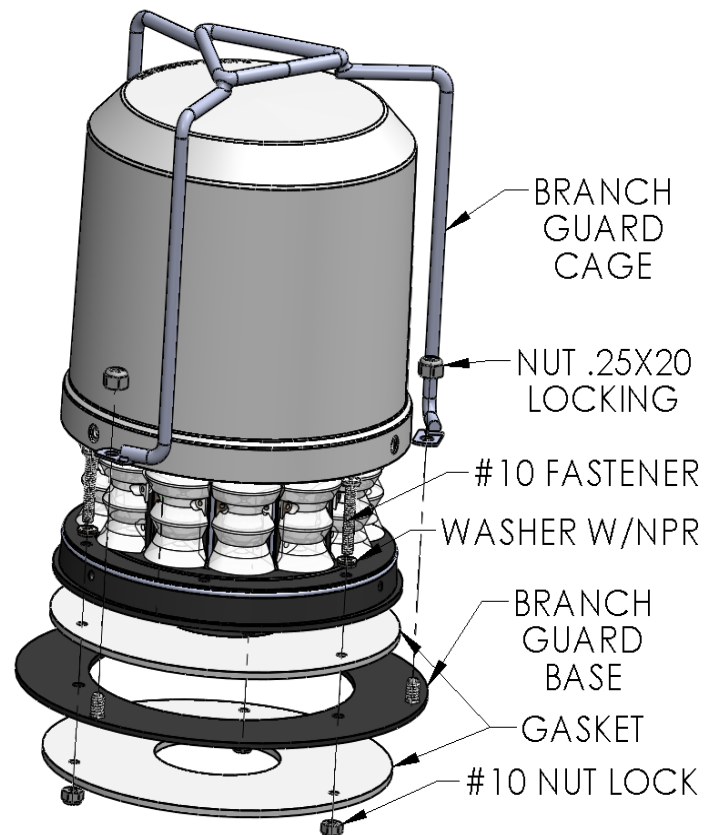

Mounting Instructions for NFPA Compliance:

Multiple beacons may be mounted at the corners of a vehicle as shown below. Some special service beacons are built where the warning signal is limited to half the circumference of the beacon. These beacons must be arranged so the warning signal faces at 45° to the longitudinal axis of the vehicle in order to comply with NFPA standards.

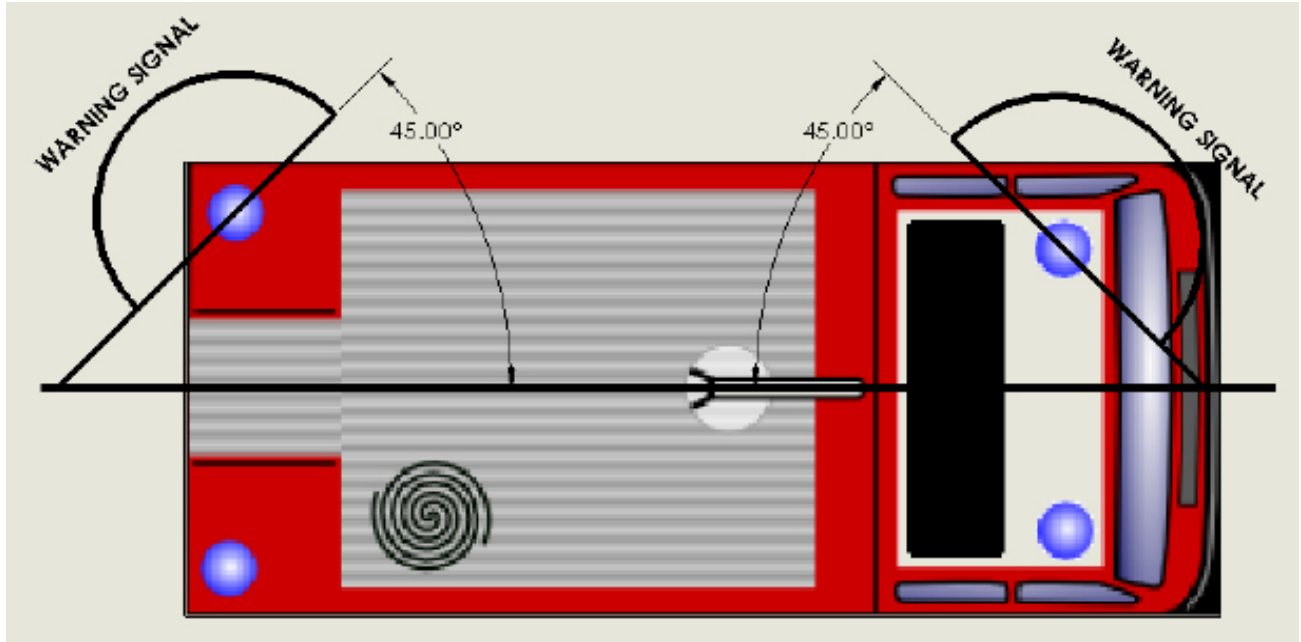

When the beacon's lens is removed for installation, the warning signal producing optic-LED assemblies can be identified by inspecting the label on the beacon base or noting the silver stars on the controller board.

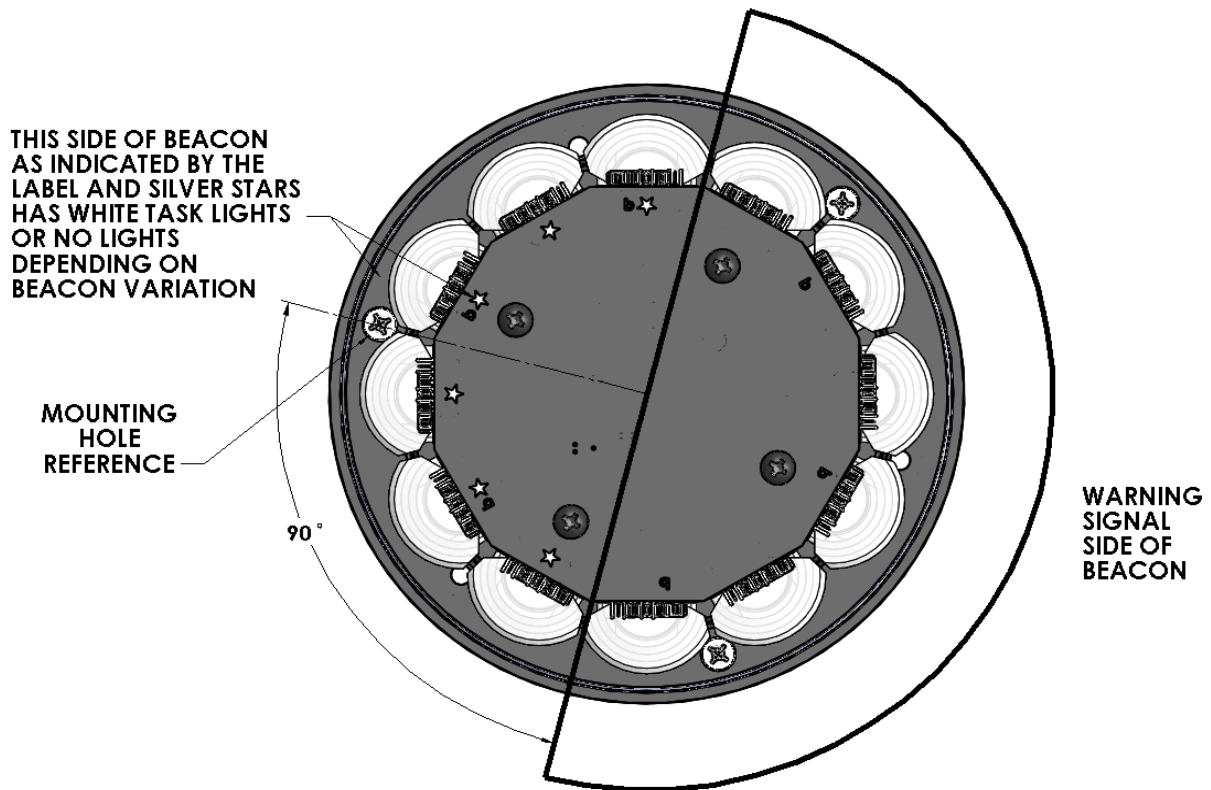

Wiring Instructions:

The beacon is terminated with a 12" long 6-wire cable harness that may be connected as follows:

<u>COLOR</u>	<u>FUNCTION</u>	<u>CONNECT TO</u>
Red	Power	+VDC
Black	Ground	Chassis ground
White	Pattern switching	Chassis ground to activate
Yellow	Synchronization	See synchronization below
Green	Failure mode detect	See failure mode detect below
Violet	Dim	+VDC to activate

Operation:

Synchronization:

To synchronize multiple beacons, configure as noted below. A maximum of 8 lights may be synchronized.

- To configure the beacons to flash their patterns simultaneously, advance the pattern for each beacon to Phase 0 mode of the chosen pattern. Connect the YELLOW wires from each beacon together. When the beacons are activated, their patterns will flash together.
- To configure the beacons to alternate their patterns, advance the pattern of either beacon (but not both) to the Phase 1 mode of the chosen pattern.

Failure Mode Detect:

This feature activates when +VDC is connected to the beacon. The following conditions are checked:

- Input voltage is at an adequate level to fully operate the beacon.
- The beacon's micro-processor is operating.

When the above are satisfied, the green wire is switched to ground and will support a current load up to 250 milli-amps. The green wire may serve to control an Indicator Light connected to +VDC that activates when the beacon is ON and is functioning. The indicator light is not provided with the beacon.

Setting the Flash Pattern:

Momentarily connect the WHITE wire to chassis ground as follows:

- For the NEXT pattern; release contact when beacon flashes ON (less than 2 seconds)
- For the PREVIOUS pattern; release contact when beacon flashes ON then OFF (2 to 4 seconds)
- For the DEFAULT pattern; release contact when beacon flashes ON then OFF then ON again (greater than 4 seconds)

Maintenance:

The beacons are designed to be maintenance free. Refer to the guide below for help with troubleshooting. Should the unit be diagnosed as malfunctioning, remove unit and replace with a new beacon.

WARNING!



LED beacon housings may become hot with extended use. Allow beacons to cool completely before attempting to remove.

TROUBLESHOOTING		
Problem	Probable Cause	Remedy
Beacon does not activate	a. No power to unit	a. Check wire for loose connection
	b. Power input wire reversed	b. Reverse power wires
	c. Damaged or shortaged cabling	c. Check cables for damage
	d. Defective beacon	d. Replace beacon module
Beacon is constantly ON	a. Control wire permanently grounded or shorted to GND	a. Avoid permanent grounding of control wire

Notes:

Notes:

WARRANTY

Code 3, Inc.'s L.E.D. emergency devices are tested and found to be operational at the time of manufacture. Provided they are installed and operated in accordance with manufacturer's recommendations, Code 3, Inc. guarantees all parts and components except the lamps to a period of 1 year, LED Lighthouse modules to a period of 5 years (unless otherwise expressed) from the date of purchase or delivery, whichever is later. Units demonstrated to be defective within the warranty period will be repaired or replaced at the factory service center at no cost.

Use of lamp or other electrical load of a wattage higher than installed or recommended by the factory, or use of inappropriate or inadequate wiring or circuit protection causes this warranty to become void. Failure or destruction of the product resulting from abuse or unusual use and/or accidents is not covered by this warranty. Code 3, Inc. shall in no way be liable for other damages including consequential, indirect or special damages whether loss is due to negligence or breach of warranty.

CODE 3, INC. MAKES NO OTHER EXPRESS OR IMPLIED WARRANTY INCLUDING, WITHOUT LIMITATION, WARRANTIES OF FITNESS OR MERCHANTABILITY, WITH RESPECT TO THIS PRODUCT.

PRODUCT RETURNS

If a product must be returned for repair or replacement*, please contact our factory to obtain a Return Goods Authorization Number (RGA number) before you ship the product to Code 3, Inc. Write the RGA number clearly on the package near the mailing label. Be sure you use sufficient packing materials to avoid damage to the product being returned while in transit.

*Code 3, Inc. reserves the right to repair or replace at its discretion. Code 3, Inc. assumes no responsibility or liability for expenses incurred for the removal and/or reinstallation of products requiring service and/or repair; nor for the packaging, handling, and shipping; nor for the handling of products return to sender after the service has been rendered.

PROBLEMS OR QUESTIONS? CALL OUR TECHNICAL ASSISTANCE HOTLINE (314) 996-2800 or visit WWW.CODE3PSE.COM, select C3 FORUM and put your question on the forum



Code 3, Inc.
10986 N. Warson Road
St. Louis, Missouri 63114-2029—USA
Ph. (314) 426-2700 Fax (314) 426-1337
www.code3pse.com