

REVISION HISTORY		
REV.	DESCRIPTION	DATE
01	PRELIMINARY RELEASE PER EP0179	2023-11-20
A	INITIAL RELEASE PER EP0179	2023-11-27

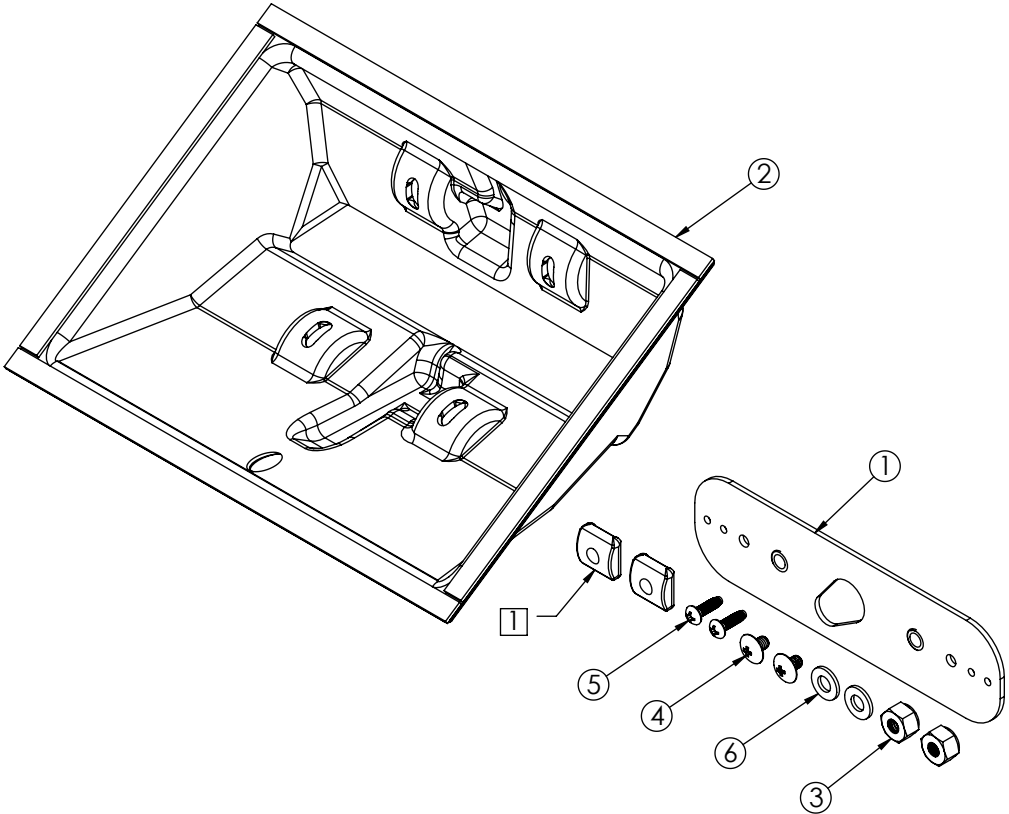

ITEM NO.	QTY.	DESCRIPTION	COMMENTS
1	1	BRACKET,SHEET,AL,WINDOW SHROUD	
2	1	ASSY,SUB,WS1L	
3	2	NUT,#8-32,HEX,NYLOC,BO,SS	
4	2	SCREW,M3.5-.6x5MM,RND,PHIL,SS	
5	2	SCREW,4-40X3/8",PAN,PHIL,BLUNT,TYPE F,BO	
6	2	WASHER,FLAT,#8,3/8OD,BO,SS	
7	3	TAPE,ADHESIVE,HOLE COVER,BLACK	NOT SHOWN
8	1	SHEET,INSTRUCTION,WINDOWSHROUD1L	NOT SHOWN
9	1	CASE (1000 PER) - POLYBAG 12" X 18", 1.5 MIL	NOT SHOWN
10	1	5 X 7 ZIPLOCK BAG	NOT SHOWN
11	1	2 x 3 ZIPLOC BAG - 2MIL CASE (1000 PER)	NOT SHOWN

NOTES:  
**1.** PLASTIC WASHER SHOWN COMES ATTACHED TO WINDOW SHROUD HOUSING MOLDING

SCALE 1:2		APPROVALS	DATE
CAD GENERATED DRAWING DO NOT MANUALLY UPDATE.		DRAWN BY BTK	2023-11-20
TOLERANCES ARE IN INCHES, AND MILLIMETERS TOLERANCES UNLESS OTHERWISE STATED ARE:		CHECKED ABD	2023-11-21
		MECH. ENG. JLA	2023-11-20
MILLIMETERS DECIMALS XX. ± 1.0mm XX.X ± 0.5mm	INCHES DECIMALS X.X ± 0.1 X.XX ± 0.04 X.XXX ± 0.02	ANGLES ± 0.5°	FRACTIONS ± 1/64
THIRD ANGLE PROJECTION		ELEC. ENG.	
		TEST ENG.	
		SALES.	
		Electronically Controlled Use Latest Copy	

**CODE 3**  
www.code3esg.com

Americas (314) 426-2700 | Europe +44 (0)113 239 1111 | Asia Pacific +61 (0)7 32937900

**WINDOW SHROUD, SINGLE**

CUSTOMER PART NO.  
**WS1L**

SIZE: **A** DWG. NO. **WS1L** REV. **A**

SHEET 1 OF 1 Project: EP0179 Date Created: 2023-11-20

PROPRIETARY AND CONFIDENTIAL INFORMATION  
 THIS DRAWING AND THE DESIGN AND OTHER INFORMATION DISCLOSED HEREIN ARE THE PROPERTY OF ELECTRONIC CONTROLS COMPANY AND/OR ITS ECCO SAFETY GROUP AFFILIATES ("CODE3") AND IS ISSUED IN CONFIDENCE TO RECIPIENT FOR ENGINEERING INFORMATION PURPOSES ONLY. THIS DRAWING AND THE DESIGN AND OTHER INFORMATION DISCLOSED HEREIN MAY NOT BE USED, COPIED, REPRODUCED OR OTHERWISE DISCLOSED IN PART OR IN WHOLE TO THIRD PARTIES OR USED FOR ANY OTHER PURPOSE WITHOUT PRIOR CODE3 WRITTEN CONSENT. CODE3 RESERVES ALL PATENT, COPYRIGHT, TRADEMARK AND OTHER PROPRIETARY RIGHTS TO THIS DOCUMENT, INCLUDING ALL DESIGN, MANUFACTURING, REPRODUCTION, USE AND SALES RIGHTS THERETO. THIS DRAWING IS SUBJECT TO RECALL BY CODE3 AT ANY TIME, AND YOUR POSSESSION AND/OR USE CONSTITUTES ACCEPTANCE OF THESE TERMS. ©2023 ELECTRONIC CONTROLS COMPANY