



ENCORE WORSHIP
CONFERENCE

Crafting Amazing Sounds with Modern Guitar Amp/Cab Modeling

Dave Miller & Mark Miller

What Is Amp/Cab Modeling?

How Is This Useful in a Worship Setting?

The Right Tool for the Job

Universal Audio OX



Universal Audio OX



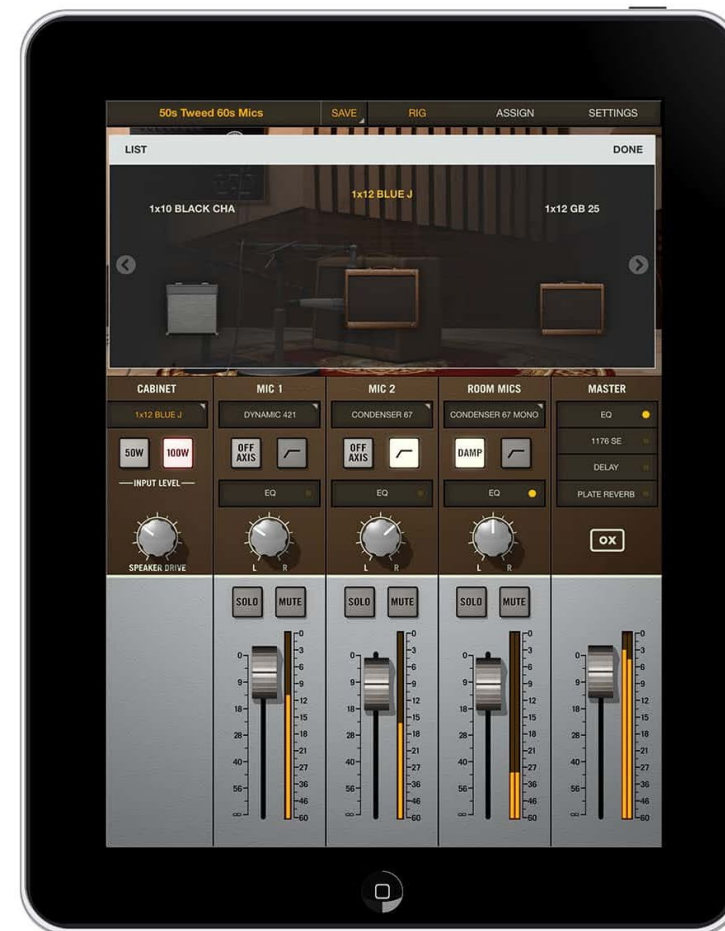
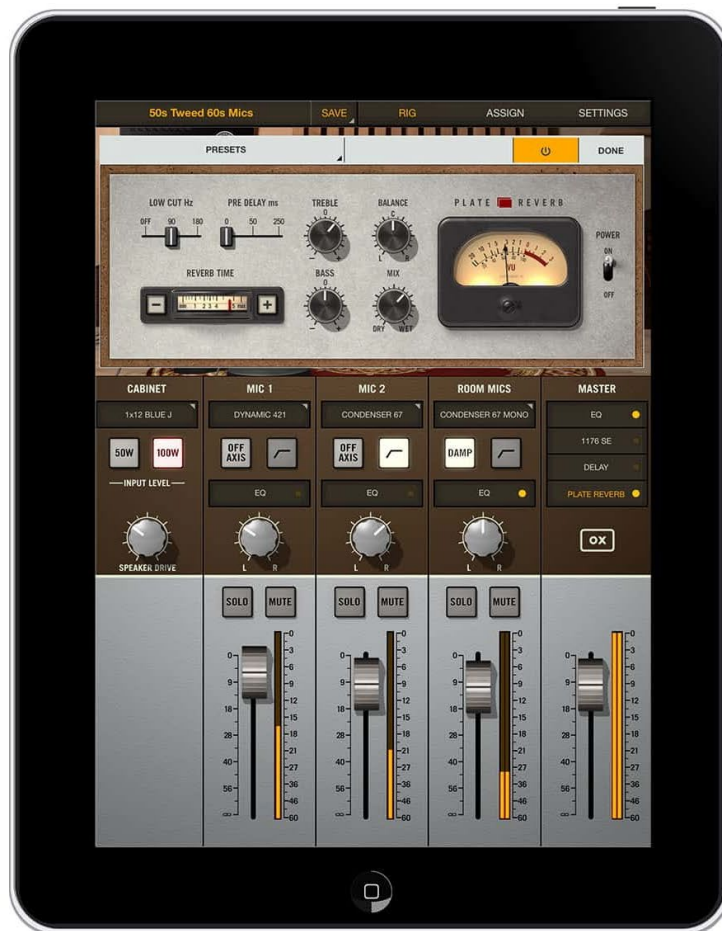
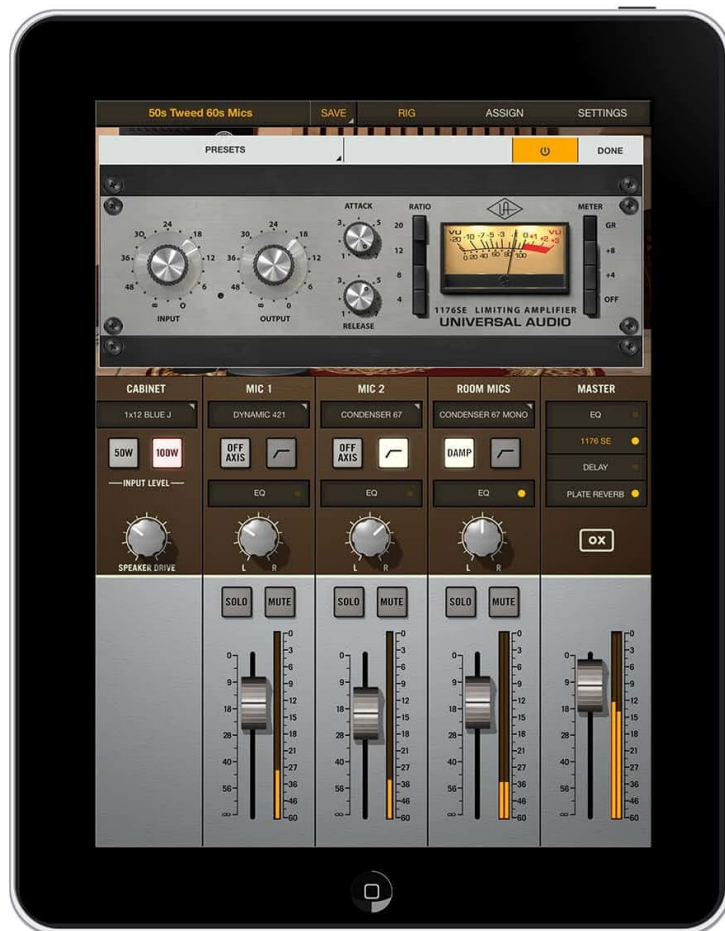

2x12 Honkin Silvers 3

SAVE

RIG

ASSIGN

SETTINGS



CABINET

MIC 1

MIC 2

ROOM MICS

MASTER

2x12 ACE TOP

RIBBON 160

CONDENSER 67

RIBBON 101 MONO

EQ

50W

100W

50W
AXIS



50W
AXIS



DAMP



DELAY



— INPUT LEVEL —

EQ



EQ



EQ



PLATE REVERB



SPEAKER DRIVE



L

R



L

R



L

R

OX

SOLO

MUTE



SOLO

MUTE



SOLO

MUTE

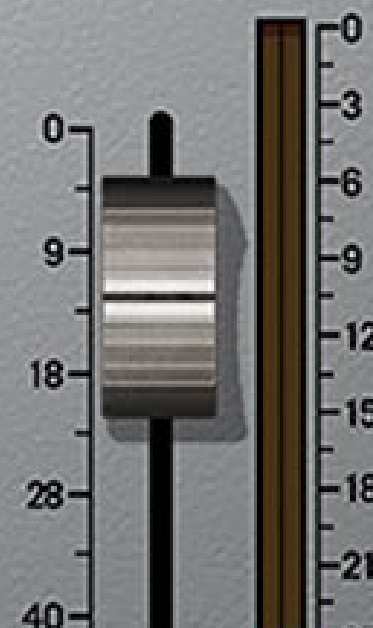
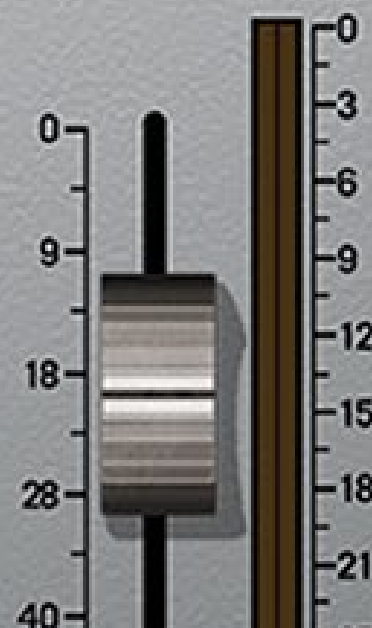

Line 6 Helix



Line 6 Helix



Helix LT



Helix LT



SETLISTS

IMPORT | EXPORT

FACTORY 1

PRESETS

COPY | PASTE | IMPORT | EXPORT

05C Brit Plexi Brt

05D PV Panama

06A Soup Pro

06B Divided Duo

06C Brit Plexi Nrm

06D Line 6 Elektrik

07A Jazz Rivet 120

07B Interstate Zed

07C Stone Age 185

07D German Mahadeva

08A US Deluxe Nrm

08B Tweed Blues Nrm

08C Brit J-45 Brt

08D Tweed Blues Brt

09A Solo Lead Clean

09B Solo Lead Crunch

09C Solo Lead OD

09D Line 6 Epic

10A Mail Order Twin

10B US Deluxe Vib

INPUT



MAIN



EDIT

AUTOMATION/CONTROLLER ASSIGN

Amp+Cab



Guitar



Divided Duo

1x12 Celest 12H



Amp+Cab



Divided Duo

Amp

Interstate Zed

Preamp

Jazz Rivet 120

Cab

Essex A15

Impulse Response

Essex A30

Volume/Pan

A30 Fawn Nrm

Send/Return

A30 Fawn Brt

Looper

Matchstick Ch1

Matchstick Ch2

Drive 1

4.0

Drive 2

1.3

Tone

2.7

Cut

6.9

Presence

0.4

Ch Vol

0.2

Line 6 Pod Go



16D Two-Plus Decades (1)

Stereo FX Loop	Parametric	Particle Verb
Heir Apparent	Simple Pitch	Adriatic Delay
Interval	Cents	Delay
Shift Level	Mix	

VIEW ACTION
SAVE
PAGE
PAGE

WAH EXP 1
VOL EXP 2

LINE 6 POD GO

MODE
EDIT / EXIT

TAP
TUNER

A B C D

Demo Time!



ENCORE WORSHIP
CONFERENCE

Crafting Amazing Sounds with Modern Guitar Amp/Cab Modeling

Dave Miller & Mark Miller