

INSTALLATION AND SETUP GUIDE

GENERAL INFORMATION

The 5800CO is a 3V battery powered wireless Carbon Monoxide (CO) detector intended for use with wireless alarm systems that support 5800 series devices. Refer to control/communicator installation instructions for compatibility.

Compatible Controls: This detector can be used with 5800 series compatible controls (Listed to UL864 and/or UL985) that support a carbon monoxide zone type and utilize a 5881 receiver.

The detector consists of an electrochemical carbon monoxide sensor assembly coupled to a wireless transmitter. The transmitter can send alarm, trouble, end-of-life, tamper, and battery condition messages to the system's receiver. Refer to the wireless system's instructions for the maximum number of transmitters that can be supported.

NOTICE: These instructions should be left with the owner/user of this equipment.

IMPORTANT: This detector must be tested and maintained regularly following NFPA 720 requirements.

WARNING: This product is not intended for use in industrial factories or commercial parking garages.

Detector Description

- Listed to UL standard 2075
CO sensitivity is evaluated to UL 2034
- Supervised
- Local sounder
- Dual LED's
- Test/Hush button
- Surface mount to wall or ceiling
- Optional drywall anchors included

The 5800CO contains a piezoelectric horn which generates the ANSI S3.41 temporal 4 pattern in an alarm condition (see note below Table 1 for temporal 4 pattern). In alarm, a message is also sent to the control panel and the detector's zone number is displayed at the console. The alarm message is transmitted every 4 seconds until the carbon monoxide condition has cleared and the detector has reset. During an alarm condition, pressing the detector's test button will silence the piezoelectric horn for five minutes. Once the detector has reset, a RESTORE message is transmitted to the control panel and the transmitter's zone number can be cleared from the panel. The mounting base installation is simplified by the incorporation of features compatible with drywall fasteners or other methods that provide a method for securing the detector in place.

Two LEDs and a sounder on the detector provide local visual and audible indication of the detector's status as listed in Table 1.

During initial power-up, the red and green LEDs will blink together once every 10 seconds four times. It takes about 30 seconds for the detector's CO sensor to stabilize (see Table 1).

After power-up has completed and the detector is functioning normally, the green LED blinks once every 10 seconds. The LED indication must not be used in place of the tests specified under **TESTING THE DETECTOR.**

Table 1: Detector LED Modes

	Green LED	Red LED	Sounder
Normal (standby)	Blinks every 10 seconds	Off	Off
Alarm/Test	Off	Blinks every 1 second	Temporal 4 Pattern†
Low Battery	Off	Blinks every 45 seconds for 37 days	Chirp every 45 sec beginning 7 days after LED blinks, continues 30 days
Detector Trouble	Off	Blinks every 5 seconds	One chirp every 45 seconds
Detector End-of-Life	Off	Blinks every 10 seconds	One chirp every 45 seconds
Power Up	Blinks every 10 secs†† (w/red LED)	Blinks every 10 secs †† (w/green LED)	Off

† Temp 4 pattern is repeated pattern of four short beeps followed by a five second pause. If ambient conditions return to normal, the detector will self-restore out of alarm and into the previous mode.

†† Red and green LEDs blink a total of four times, once every 10 seconds.

Hush feature: If required, the audible alarm can be silenced for five minutes by pushing the Test button. The red alarm light will continue to flash in temp-4 pattern. If carbon monoxide is still present after the 5-minute hush period, the audible alarm will sound. The hush feature will not operate at levels above 350 ppm (parts per million) carbon monoxide.

Trouble feature: When the sensor supervision is in a trouble condition, the detector will send a trouble signal to the panel. The red LED blinks once every five seconds. Trouble conditions include an open circuit, ~~sensor removal (tamper)~~, and sensor end of life.

End of Life Timer feature: When the detector has reached the end of its life, the detector will send a trouble signal to the panel. This indicates that the CO sensor inside the detector has passed the end of its life and the detector must be replaced. This detector's lifespan is approximately six years from the date of manufacture. Refer to Detector Replacement section.

Low Battery Detection: The 5800CO is powered by a single 3-volt CR123A or DL123A Lithium battery (included). The detector checks for a low battery at least every 65 minutes. If a low battery is detected, the transmitter sends a low battery message to the control panel, which beeps and displays the detector's zone number. In addition, the red LED of the detector will blink every 45 seconds. After 7 days the detector's horn will "chirp" about every 45 seconds (red LED continues to blink) for up to 30 days. Pressing the test button during this time will silence the chirps for 12 hours, if no other trouble conditions exist. The battery should be replaced BEFORE the chirps begin. Be sure to replace the battery with a fresh one.

This device complies with Part 15 of the FCC rules and RSS210 of Industry Canada. Operation is subject to the following two conditions: (1) This device may not cause harmful interference, and (2) This device must accept any interference received, including interference that may cause undesired operation.

Unauthorized changes or modifications could void the user's authority to operate the equipment.

BATTERY INSTALLATION AND REPLACEMENT

To replace the battery:

1. Remove the detector from its mounting base by twisting the detector counterclockwise. Remove the battery and dispose of properly.
2. To ensure proper power-down sequence, wait a minimum of 20 seconds before installing new battery.
3. Install a new 3-volt CR123A Lithium battery in the battery compartment. Follow the polarity diagram inside the compartment.
4. Reinstall the detector onto the mounting base by turning the detector clockwise.
5. Test the detector as described in the TESTING SIGNAL STRENGTH section of this manual. The green LED should blink about once every 10 seconds to indicate normal operation. If the battery is not installed correctly, the detector will not operate and the battery may be damaged. If the detector does not appear to be sending a signal during any of the tests, check for correct battery installation and for a fully charged battery.

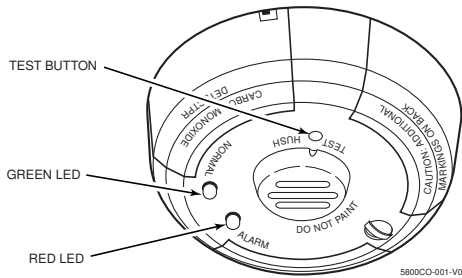

Figure 1. 5800CO Wireless Carbon Monoxide Detector

PROGRAMMING

The detector must be enrolled in the control panel before it can operate in the system. Alarms and trouble conditions from the detector are reported on one protection zone, which is programmed as carbon monoxide zone type (zone type 14 for Honeywell residential controls).

Events reported include the following:

Event	Alpha Keypad	CS Report
alarms	CO Alarm	CO alarm (CID 162)
test	CO Alarm	CO alarm (CID 162)
low battery	Lo Bat	RF low-battery (CID 384)
detector supervision	CO Trouble	RF sensor supervision (CID 381)
detector end-of-life detector trouble	CO Trouble	sensor trouble - end-of-life (CID 380)
tamper	disarmed = CO Trouble armed = CO Alarm	RF sensor tamper (CID 383)

1. Enter the control's Zone Programming mode.
 2. Enter the alarm zone number to be programmed.
 3. Enter the applicable zone type when prompted. Use zone type 14 for Honeywell residential controls.
 4. When prompted, enter Input Type 03 (3 on some controls) – Supervised RF Transmitter.
 5. When prompted for the serial number, do the following:
 - a. Remove the detector from its base (rotate the detector counterclockwise on the base until it snaps open).
 - NOTE:** Detector must be removed from the base to enroll.
 - b. Press the detector's Test button twice (for each press, hold the button down several seconds).
 - c. Reinstall the detector on its base (twist clockwise until the detector snaps into place).
 - d. Check that the detector is enrolled as loop 1.
 6. Exit Programming mode when programming is complete, and test the detector. Refer to the Testing Section.
- See the control unit's installation instructions for more details.

MOUNTING THE DETECTOR

First, determine the best location for the detector, one that provides proper carbon monoxide detection (see Figure 4 for suggested detection locations) and a strong wireless transmission path.

Proper Carbon Monoxide Detection Location

In a wall location, the detector should be at least as high as a light switch, and at least six inches from the ceiling. In a ceiling location, the detector should be at least 12 inches from any wall.

Where to install, ideally:

- Within 10 feet of all sleeping areas
- Inside the bedroom if it contains a fuel burning appliance
- On every floor of the building
- Ideally, install in any room that contains a fuel burning appliance
- If the appliance in the room is not normally used, such as the boiler room, the detector should be placed just outside the room so the alarm can be heard more easily

Where NOT to install, ideally:

- Detectors operate best if not installed within 10 feet of any cooking appliance
- Directly above a sink, cooker, stove or oven
- Next to a door or window that would be affected by drafts i.e. extractor fan or air vent
- Outside
- Do not install in any environment that does not comply with the detector's environmental specifications
- In or below a cupboard
- Where air flow would be obstructed by curtains or furniture
- Where dirt or dust could collect and block the sensor
- Where it could be knocked, damaged, or inadvertently removed

Good Transmission Path

A GOOD TRANSMISSION PATH MUST BE ESTABLISHED FROM THE PROPOSED MOUNTING LOCATION BEFORE PERMANENTLY INSTALLING THE DETECTOR. To check, perform the test described in the TESTING SIGNAL STRENGTH section. Prior to mounting the detector to the mounting base, you must "enroll" the detector's serial number into the system (see the PROGRAMMING section).

Mounting Procedure

Once a suitable location is found, mount the detector as follows:

1. Refer to the diagram below and install the mounting base on the ceiling or on the wall (if local ordinances permit) using screw locations "A" or "B" as required. Use the two screws and anchors provided. Maneuver the base so the screws are at the elbow of the screw slots and secure.
2. Fit the detector inside the base by aligning it over the base as shown (detector's alignment notch should be slightly offset from mounting base tamper release tab), then turn the detector in a clockwise direction until it clicks into place.
3. Test the detector after completing the installation (as described in the TESTING THE DETECTOR section of this manual) and refer to the control system's instructions for additional information concerning the use of wireless devices.

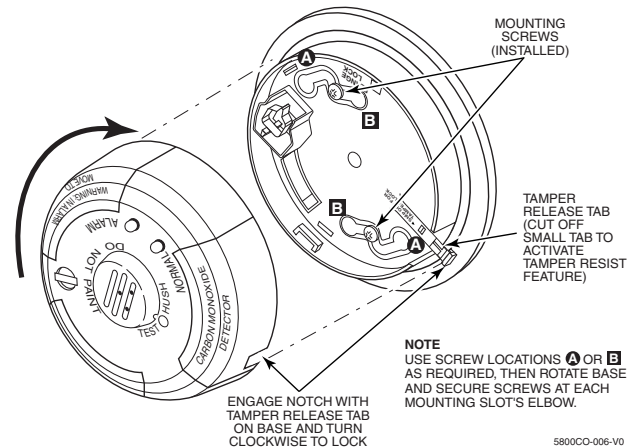

Figure 2. Mounting the Detector

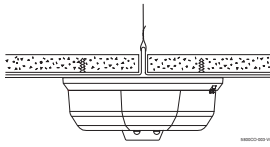

Figure 3. Mount Detector Across Ceiling Panel Support

DO NOT attach the detector to removable ceiling panels. Attach the detector across panel support as shown in Figure 3.

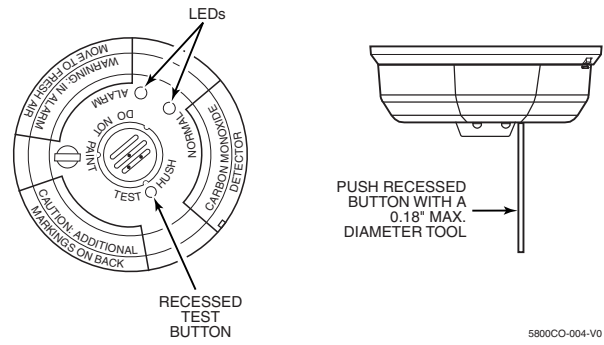

Figure 5. Recessed Test Button Opening

CAUTION

Airborne dust particles can enter the detector. Honeywell recommends the removal of detectors before beginning construction or any other dust producing activity. Carbon monoxide detectors are not to be used with detector guards unless the combination has been evaluated and found suitable for that purpose.

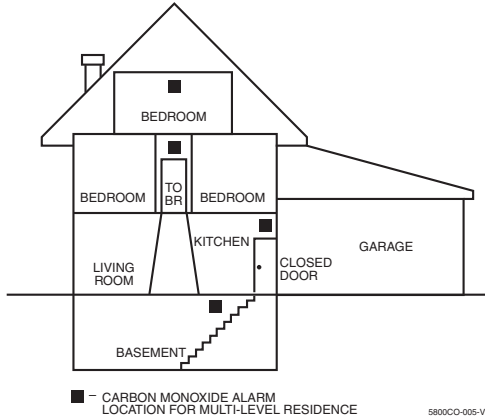

Figure 4. Detector Location Diagram

Tamper Protection

This detector has a built-in tamper switch that will cause a CHECK signal to be displayed at the console of the alarm system if it is removed from its mounting base while the system is disarmed (alarm occurs if system is armed). The 5800CO detector includes a tamper-resistant feature that prevents removal from the mounting base without the use of a tool. To engage the tamper-resistant feature, cut the small plastic tab located on the mounting base (Figure 2), and then install the detector. To remove the detector from the base once it has been made tamper resistant, use a small screwdriver to depress the square tamper release tab, located on the skirt of the mounting base, and turn the detector counterclockwise.

TESTING THE DETECTOR

NOTE: Before testing, notify the central station that the detector system is undergoing maintenance, in order to prevent unwanted alarms. Testing the detector will activate an alarm and send a signal to the panel. Also, the test function cannot be used if the detector has a trouble or end-of-life condition.

The manufacturer cannot recommend a specific agent with which to test the detector.

Detectors must be tested after installation and following periodic maintenance.

Testing Detector Operation

This test checks the detector's sounds, LEDs, and transmitter.

1. A recessed test button is located on the detector housing (see Figure 5).
2. Push and hold the recessed test button for a minimum of 5 seconds. Use a small screwdriver or Allen key with maximum diameter of 0.18 inch. The alarm panel will trigger and then the detector will go into alarm. The sounder begins the temporal 4 pattern and the red LED blinks. The alarm panel's keypad should display the detector's zone number in alarm. If the tool is removed from the recessed button the sounder will shut off and red LED stops blinking.

Testing Signal Strength

NOTE: Remove battery tab before installation.

This test should be performed before installation to determine a strong communication path with the control panel and after installation is complete. Also, the owner/user should test the unit's signal strength at least weekly.

1. Activate the wireless system's GO/NO GO TEST mode from the keypad (refer to the control's instruction manual).
2. Depress and hold the detector's TEST button. If the detector has not previously detected a low battery condition and it is within proper sensitivity limits, the detector should immediately transmit an alarm signal to the control panel. The built-in horn will start to sound about 2.5 seconds after depressing the button.
3. The wireless system's keypad should emit at least three audible sounds when the alarm transmission is received and will display the transmitting detector's zone number.
4. When the console has received the test signal, release the TEST button. The horn will stop and a few seconds later the detector's zone number will clear from the console display.
5. If the console does not respond as noted, check the polarity of the battery and be sure it is fresh. If this is an initial installation, try moving the detector to another location that provides proper reception. Also be sure that the detector has been "enrolled" by the control panel (see PROGRAMMING). Then, repeat the test.
6. Turn off the system's TEST mode from the keypad (security code + OFF).

Testing Programmed Loops

This test should be performed before installation to ensure that the detector has been programmed and is operational in the system.

1. Activate the system's TRANSMITTER ID SNIFFER mode from the keypad (see the control panel's instructions). All programmed wireless zones will be displayed, one by one, on the system keypad. Make sure the detector zone is displayed in the sequence. (If not, recheck that the detector zone has been properly programmed.)
2. With the detector mounted to the mounting base, press the detector's TEST button. The zone associated with the detector should disappear from the keypad on the next display cycle. This means that the system has received a transmission from the detector zone you programmed.
3. When testing is complete, enter the Installer code + the OFF key to exit TEST mode.

When all system testing has been completed, notify the central station that the system is back on line.

CAUTION: Carbon Monoxide Gas and its Detection

This carbon monoxide detector is designed for indoor use only. Do not expose to rain or moisture. Do not knock or drop the detector. Do not open or tamper with the detector as this could cause malfunction. The detector will not protect against the risk of carbon monoxide poisoning if not properly installed. The detector will only indicate the presence of carbon monoxide gas at the sensor.

Carbon monoxide gas may be present in other areas.

This carbon monoxide detector is NOT:

- Designed to detect smoke, fire or any gas other than carbon monoxide
- To be seen as a substitute for the proper servicing of fuel-burning appliances or the sweeping of chimneys.
- To be used on an intermittent basis, or as a portable alarm for the spillage of combustion products from fuel-burning appliances or chimneys.

Carbon monoxide gas is a highly poisonous gas which is released when fuels are burned. It is invisible, has no smell and is therefore impossible to detect with the human senses. Under normal conditions in a room where fuel burning appliances are well maintained and correctly ventilated, the amount of carbon monoxide released into the room by appliances should not be dangerous.

Symptoms of carbon monoxide poisoning: Carbon monoxide bonds to the hemoglobin in the blood and reduces the amount of oxygen being circulated in the body. The following symptoms are related to carbon monoxide poisoning and should be discussed with all members of the household:

Mild exposure: Slight headache, nausea, vomiting, fatigue (often described as "flu-like" symptoms).

Medium exposure: Severe throbbing headache, drowsiness, confusion, fast heart rate.

Extreme exposure: Unconsciousness, convulsions, cardio respiratory failure, death.

Many causes of reported carbon monoxide poisoning indicate that while victims are aware that they are not well, they become so disoriented that they are unable to save themselves by either exiting the building or calling for assistance.

Also young children and pets may be the first to be affected.



WARNING: IMPORTANT INFORMATION FOR THE USER

Actuation of your CO alarm indicates the presence of carbon monoxide (CO), which can cause injury or death.

Individuals with medical problems may consider using warning devices which provide audible and visual signals for carbon monoxide concentrations under 30ppm.

What to do if the carbon monoxide detector goes into alarm:

1. Push the Hush/Test button. If the detector reactivates or the detector does not silence, continue with step 2.
2. Immediately move to fresh air, outdoors or by an open window. Check that all persons are accounted for. Do not reenter the premises nor move away from the open door/window until emergency service responders have arrived.
3. Call your local fire department from a phone in an area where the air is safe.
4. If your detector reactivates within a 24-hour period, repeat steps 1-3 and call a qualified appliance technician to investigate for sources of CO from fuel burning equipment and appliances, and inspect for proper operation of this equipment. If problems are identified during this inspection, have the equipment serviced immediately. Note any combustion equipment not inspected by the technician and consult the manufacturer's instructions, or contact the manufacturers directly, for more information about CO safety and this equipment. Make sure that motor vehicles are not, and have not been, operating in an attached garage or adjacent to the residence.

IMPORTANT: This detector should be tested and maintained regularly following National Fire Protection Association (NFPA) 720 requirements. (Generally this detector should be tested at least once per month.)

MAINTENANCE

Occasionally clean the outside casing with a cloth. Ensure that the holes on the front of the alarm are not blocked with dirt and dust. **Do not paint, and do not use cleaning agents, bleach, or polish on the detector.**

DETECTOR REPLACEMENT

This detector is manufactured with a long-life carbon monoxide sensor. Over time the sensor will lose sensitivity, and will need to be replaced with a new carbon monoxide detector. This detector's lifespan is approximately six years from the date of manufacture.

The user should periodically check the detector's replacement date. Remove the detector from its base and check the replacement date label on the underside of the detector. The label indicates the date that the detector should be replaced.

NOTE: When the detector is removed from its base, a message is sent to the central station. If the system is armed, a tamper alarm message is sent; if disarmed, a trouble message is sent.

The detector will also cause a trouble condition once it has reached the end of its useful life. If this occurs, it is time to replace the detector.

NOTE: Before replacing the detector, notify the proper authorities that maintenance is being performed and the system will be temporarily out of service. Disable the zone or system undergoing maintenance to prevent any unwanted alarms. Dispose of detector in accordance with any local regulations.

CAUTION

It should be noted the installation, operation, testing and maintenance of the 5800CO is different than smoke detectors. Per NFPA 720 section 5.3.7.2 the detector shall not be connected to a zone that signals a fire condition (i.e. smoke detector zones). Therefore, the 5800CO detector must be programmed as a non-fire zone. See the control's Installation Instructions for the appropriate carbon monoxide zone type to be programmed.

SPECIFICATIONS

Power Source:	One 3-volt CR123A Lithium Battery (included). (Replace with Duracell DL123A, Panasonic CR123A or ADEMCO 466.)
Audible Signal (temp 4 tone):	85 dBA min. in alarm (at 10ft)
Height:	2.3 inches (58 mm)
Diameter:	5.3 inches (135 mm) with mounting base
Weight:	7 oz. (241 g) without battery
Operating Ambient Temperature Range:	32° to 100°F (0° to 37.8°C)
Operating Humidity Range:	15% to 95% Relative Humidity, non-condensing
Agency Listings:	UL standard 2075
Patent numbers:	7,120,795

Please see insert for Limitations of Carbon Monoxide Detectors.

FOR WARRANTY INFORMATION AND FOR DETAILS REGARDING THE LIMITATIONS OF THE ENTIRE ALARM SYSTEM, GO TO:
www.honeywell.com/security/hsc/resources/wa



K14631V1 4/08 Rev. B

Honeywell

2 Corporate Center Drive, Suite 100
P.O. Box 9040, Melville, NY 11747

Copyright © 2007 Honeywell International Inc.

www.security.honeywell.com