

INSTALLATION AND SETUP GUIDE

General Information

Before installing detectors, please thoroughly read these installation instructions and *Guide for Proper Use of System Smoke Detectors* (A05-1003-002), which provides detailed information on detector spacing, placement, zoning, wiring, and special applications. Copies of this manual are available from Honeywell.

NOTICE: This manual should be left with the owner/user of this equipment.

IMPORTANT: This detector must be tested and maintained regularly following NFPA 72 requirements.

General Description

The 5808W3 photoelectronic smoke/heat detector with built-in wireless transmitter is intended for use with wireless alarm systems that support 5800 series devices. Refer to control/communicator installation instructions for compatibility. The 5808W3 smoke/heat detector can be used with any 5800 series wireless receiver/transceiver for residential installations. For commercial installations, the 5881ENHC or the 5883H receiver is required. The transmitter can send alarm, tamper, maintenance (when control panels are equipped to process maintenance signals), and battery condition messages to the system's receiver. The maintenance signal fully complies with the sensitivity test requirement specified in NFPA 72, 10.4.4.2.4 and is approved by UL. Refer to the wireless system's instructions for the maximum number of transmitters that can be supported.

The 5808W3 incorporates a state-of-the-art optical sensing chamber and an advanced microprocessor. The microprocessor allows the detector to automatically maintain proper operation at factory calibrated detection levels, even when sensitivity is altered due to the presence of contaminants settling into the unit's smoke chamber. In order for this feature to work properly, the chamber must never be opened while power is applied to the smoke detector. This includes cleaning, maintenance or screen replacement. All models also feature a restorable, built-in, fixed temperature (135°F) thermal detector and is also capable of sensing a pre-freeze condition if the temperature is below 41°F.

The 5808W3 contains a piezoelectric horn which generates the ANSI S3.41 temporal pattern in an alarm condition. In alarm, a message is also sent to the wireless control panel. The alarm message is transmitted every 4 seconds until the smoke or heat condition has cleared and the detector has reset. During an alarm condition, pressing the detector's test switch will silence the piezoelectric horn for 5 minutes. Once the detector has reset, a RESTORE message is transmitted to the control panel. The built-in Drift Compensation algorithm automatically maintains the sensitivity of the detector. Once the detector reaches its limit of compensation, it transmits a maintenance signal to the panel. The mounting base installation is simplified by the incorporation of features compatible with drywall fasteners or other methods that provide a method for securing the detector in place.

Two LEDs and a sounder on the detector provide local visual and audible indication of the detector's status:

Table 1: Detector LED Modes

	Green LED	Red LED	Piezoelectric Horn
Power Up	Blinks every 5 sec	Blinks every 5 sec	Off
Normal (standby)	Blinks every 10 sec	Off	Off
Out of Sensitivity	Off	Blinks every 5 sec	Off
Freeze Trouble	Off	Blinks every 10 sec	Off
Smoke Alarm	Off	Blinks every 1 sec	Temporal Pattern
Thermal Alarm	Off	Blinks every 4 sec	Temporal Pattern
Low Battery	Off	Blinks every 45 sec	Chip every 45 sec after LED blinks for 7 days

During initial power-up, the red and green LEDs will blink synchronously once every 5 seconds. It will take approximately 20 seconds for the detector to finish the power-up cycle (see Table 1).

After power-up has completed and the detector is functioning normally within its listed sensitivity range, the green LED blinks once every 10 seconds. If the detector is in need of maintenance because its sensitivity has shifted outside the listed limits, the red LED blinks once every 5 seconds. When alarm has been activated by smoke, the red LED blinks every 1 second. During a thermal alarm condition (>135°F) the red LED blinks once every 4 seconds. The LED indication must not be used in place of the tests specified under Testing. In a freeze trouble condition, the red LED will blink once every 10 seconds (refer to Table 1). If the detector senses a low battery condition, the red LED blinks once every 45 seconds.

To measure the detector's sensitivity, the i3 Series Model SENS-RDR Infrared Sensitivity Reader tool (see Figure 4) should be used. Refer to instruction manual D100-98-00 for proper use of the SENS-RDR.

Low Battery Detection

The 5808W3 is powered by a single 3-volt CR123A or DL123A Lithium battery (included). The detector checks for a low battery at least every 65 minutes. If a low battery is detected, the transmitter sends a low battery message to the control panel, which beeps and displays the detector's zone number. In addition, the red LED of the 5808W3 will blink every 45 seconds and the test switch will be disabled. This condition will exist for a minimum of 7 days, and then the detector's horn will "chirp" about every 45 seconds. Pressing the test switch during this time will silence the chirps for 12 hours. The battery should be replaced BEFORE the chirps begin. Be sure to replace the battery with a fresh one.

Battery Installation and Replacement

To replace the battery:

1. Remove the detector from its mounting base by twisting the detector counterclockwise. Remove the battery, and dispose properly.
2. To ensure proper power-down sequence, wait a minimum of 20 seconds before installing new battery.
3. Install a new 3-volt CR123A Lithium battery in the battery compartment. Follow the polarity diagram inside the compartment.
4. Reinstall the smoke detector onto the mounting base by turning the detector clockwise.
5. Test the detector as described in the TESTING SIGNAL STRENGTH section of this manual. The green LED should blink about once every 10 seconds to indicate normal operation. If the battery is not installed correctly, the smoke detector will not operate and the battery may be damaged. If the detector does not appear to be sending a signal during any of the tests, check for correct battery installation and for a fully charged battery.

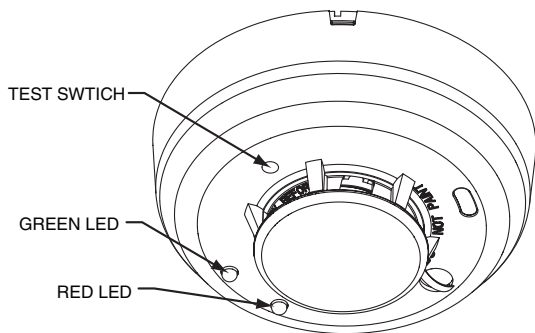

S0289-00

Figure 1. 5808W3 Wireless Smoke/Heat Detector

Programming

The smoke detector must be enrolled in the control panel before it can operate in the system. The 5808W3 smoke/heat protection zone must be enrolled as Loop 1 and “Input Type” 3 (supervised RF).

If programmed, this smoke detector is capable of monitoring the additional conditions of Maintenance (transmitted as Loop 2), and Low Temperature (transmitted as Loop 3). Tamper is transmitted as Loop 4, but does not require programming. To take advantage of the value added features of Maintenance and Low Temperature, you must program each loop as a separate zone in the 5800 series wireless compatible panel.

1. Enter the control’s Zone Programming mode.
2. Enter the zone number to be programmed.
3. Enter the applicable zone type when prompted. Program
 - Loop 1 (Heat/Smoke) as a Fire zone (type 9 or 16),
 - ~~Loop 2 (High/Low Maintenance) as a 24-Hr. Trouble zone (type 19), and~~
 - Loop 3 (Freeze Warning Sensor) as a 24-Hr. Aux. zone (type 8).

NOTE: ~~Loop 2~~ High/Low Maintenance is supported only on commercial control panels such as the Vista-128FBP.

4. When prompted, enter Input Type 03 (3 on some controls) – Supervised RF Transmitter.
5. When prompted for the serial number, transmit from the detector by activating the tamper switch. To do this, hold the base of the detector in one hand, and rotate the detector counter-clockwise on the base until it snaps open. Then return to clockwise position until the detector snaps into place.

6. When the serial number is displayed, transmit from the detector a second time by activating the tamper switch again as described in Step 5. The current loop number (4) will begin to flash.
7. Manually change the loop number to the desired loop number for the zone (according to the application).
8. When programming for this zone is complete, program other zones for the transmitter as necessary (except for Tamper Loop 4, which does not require programming).

WARNING: The fire protection zone enrolled must always be Loop 1. Otherwise, fire annunciations will not be reported by the control.

9. Exit Programming mode when programming is complete, and test the detector. Refer to the Testing Section.

See the control unit’s installation instructions for further details.

Mounting

First, determine the best location for the smoke detector, one that provides a strong wireless transmission path and proper smoke detection. A GOOD TRANSMISSION PATH MUST BE ESTABLISHED FROM THE PROPOSED MOUNTING LOCATION BEFORE PERMANENTLY INSTALLING THE DETECTOR. To check, perform the test described in the TESTING SIGNAL STRENGTH section of this manual. Prior to mounting the detector to the mounting base, you must “enroll” the detector’s serial number into the system (see the PROGRAMMING section). To mount the detector, perform the following steps:

1. Once a suitable location has been determined, install the mounting base on the ceiling or on the wall (if local ordinances permit). Use the two screws and anchors provided.
2. Turn the detector in a clockwise direction in the mounting base until it clicks into place.
3. Test the detector immediately after completing the installation (as described in the TESTING section of this manual) and refer to the control system’s instructions for additional information concerning the use of wireless smoke detectors.

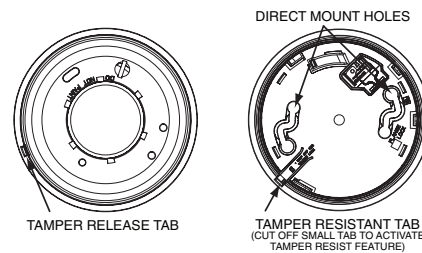

S0290-00

Figure 2. Detector Mounting Base

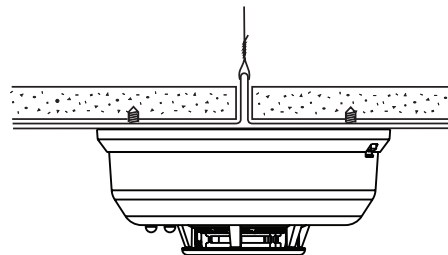

S0162-01

Figure 3. Mount Detector Across Ceiling Panel Support



DO NOT attach the detector to removable ceiling panels. Attach the detector across panel support as shown in Figure 3.

Dust covers are an effective way to limit the entry of dust into the smoke detector sensing chamber during construction. However, they may not completely prevent airborne dust particles from entering the detector. Therefore, it is recommended that the detectors be removed before beginning construction or other dust producing activity. When returning the system to service, be sure to remove the dust covers from any detectors that were left in place during construction.

Smoke detectors are not to be used with detector guards unless the combination has been evaluated and found suitable for that purpose.

Tamper Protection

This detector has a built-in tamper switch that will cause a CHECK signal to be displayed at the console of the alarm system if it is removed from its mounting base. The 5808W3 detector includes a tamper-resistant feature that prevents removal from the mounting base without the use of a tool. To engage the tamper-resistant feature, cut the small plastic tab located on the mounting base (Figure 2), and then install the detector. To remove the detector from the base once it has been made tamper resistant, use a small screwdriver to depress the square tamper release tab, located on the skirt of the mounting base, and turn the detector counterclockwise.

Testing the Sensor

NOTE: Before testing, notify the central station that the smoke detector system is undergoing maintenance, in order to prevent unwanted alarms.

During initial power-up, do not use SENS-RDR or canned smoke to test the detector. The SENS-RDR and canned aerosol can be used after power-up sequence has completed. Detectors must be tested after installation and following periodic maintenance. The 5808W3 may be tested as follows:

A. Test Switch

1. A recessed test switch is located on the detector housing (see Figure 4).
2. Push and hold the recessed test switch for a minimum of 5 seconds. Use a small screwdriver or Allen key with maximum diameter of 0.18 inch (the alarm panel will trigger and then the smoke detector will go into alarm. If the tool is removed from the recessed switch the sounder will shut off.)

If the detector is within the listed sensitivity limits, the LED on the detector should blink once per second and the horn should sound within 3 seconds.

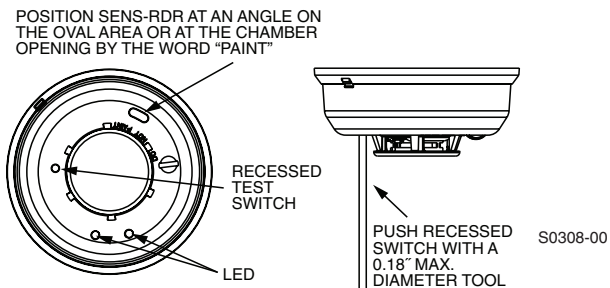

Figure 4. Recessed Test Switch Opening and SENS-RDR Position

B. Smoke Entry Test

A canned smoke agent may be used to test the detector. Refer to the manufacturer's instructions for proper use of the canned smoke. HSI brand canned smoke has been tested and approved for use with this type of smoke detector.

C. Direct Heat Method (Hair dryer of 1000-1500 watts)

Direct the heat toward either side thermistor. Be sure to hold the heat source about 12 inches from the detector to avoid damage to the plastic. The detector will reset only after it has time to cool.

Smoke detection testing is recommended for verifying system protection capability.

A detector that fails to activate with any of these tests should first be cleaned as outlined in this manual's MAINTENANCE section. If the detector still fails to activate, return for repair.

Testing Signal Strength

NOTE: Remove battery tab before installation.

This test should be performed in accordance with NFPA 72 inspection, testing and maintenance requirements to determine a strong communication path with the control panel.

1. Activate the wireless system's GO/NO GO TEST mode from the keypad.
2. Depress and hold the smoke detector's TEST switch. If the detector has not previously detected a low battery condition and it is within proper sensitivity limits, the detector should immediately transmit an alarm signal to the control panel. The built-in horn will start to sound about 2.5 seconds after depressing the button.
3. The wireless system's keypad should emit at least three audible sounds when the alarm transmission is received and will display the transmitting detector's zone number.
4. When the console has received the test signal, release the TEST switch. The horn will immediately stop and a few seconds later the detector's zone number will clear from the console display.
5. If the console does not respond as noted, check the polarity of the battery and be sure it is fresh. If this is an initial installation, try moving the detector to another location that provides proper reception. Also be sure that the detector has been "enrolled" by the control panel (see PROGRAMMING). Then, repeat the test.
6. Turn off the system's TEST mode from the keypad (security code + OFF).

Testing Programmed Loops

This test should be performed before installation to ensure that all loops intended to be used have been programmed and are operational in the system.

1. Activate the system's TRANSMITTER ID SNIFFER mode from the keypad (see the control panel's instructions). All programmed wireless zones will be displayed, one by one, on the system keypad. Make sure all smoke detector zones are displayed in the sequence. (If they are not, recheck that all zones have been properly programmed.)
2. With the detector mounted to the bracket, press the smoke detector's TEST switch. All zones associated with the smoke detector should disappear from the keypad on the next display cycle. This means that the system has received a transmission from each loop you programmed.
3. When testing is complete, enter the Installer code + the OFF key to exit TEST mode.

When all system testing has been completed, notify the central station that the system is back on line.

Maintenance

NOTE: Before performing maintenance on the detector, notify the proper authorities and the central station that maintenance is being performed and the system will be temporarily out of service. Disable the zone or system undergoing maintenance to prevent any unwanted alarms, and follow this procedure exactly, referring to Figure 5.

1. Remove the detector housing from the base by twisting counter-clockwise.
2. Remove the battery from the unit.
3. Wait 20 seconds. (To ensure proper power-down sequence, the battery must be removed from detector for a minimum of 20 seconds before continuing to the next step.)
4. Remove the detector cover by turning counter-clockwise.
5. Vacuum the cover or use canned air to remove any dust or debris.
6. Remove the top half of the screen/sensing chamber by lifting straight up (see Figure 5).
7. Vacuum or use canned air to remove any dust or particles that are present on all chamber sections.
8. Replace the top half of the screen/sensing chamber by aligning the arrow on the screen/sensing chamber with the arrow on the housing. Press down firmly until the screen/sensing chamber is fully seated.
9. Replace the detector cover by placing it over the screen/sensing chamber and turning it clockwise until it snaps into place.

10. Reinstall the battery into the battery compartment noting proper orientation. The red and green LEDs will flash once every 5 seconds for approximately 20 seconds until the power-up cycle is complete.
11. Reinstall the detector and test (see the Testing section).
12. Notify the central station when the system is back in service.

IMPORTANT: If this procedure is not followed exactly, the detector may indicate a maintenance trouble after the power-up sequence is complete. If this happens, remove the battery for 20 seconds and then reinstall.

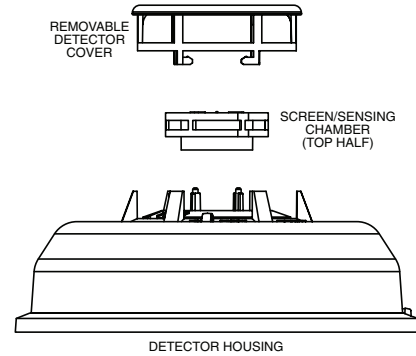

S0111-00

Figure 5. Removing Screen/Sensing Chamber

Specifications

Power Source:	One 3-volt CR123A Lithium Battery (included). (Replace with Duracell DL123A, Sanyo CR123A, Panasonic CR123A or ADEMCO 466.)
Height:	2.3 inches (58 mm)
Diameter:	5.3 inches (135 mm) with mounting base
Weight:	8.5 oz. (241 g) without battery
Operating Ambient Temperature Range:	32° to 100°F (0° to 38°C)
Operating Humidity Range:	0% to 95% Relative Humidity
Heat Sensor:	135° F Fixed Temperature Electronic Thermistors
Freeze Warning Sensor:	41°F (5°C)
Agency Listings:	UL 268 – Commercial and Residential Installations

Please refer to insert for the Limitations of Fire Alarm Systems

FOR WARRANTY INFORMATION AND FOR DETAILS REGARDING THE LIMITATIONS OF THE ENTIRE ALARM SYSTEM, REFER TO THE INSTALLATION INSTRUCTIONS FOR THE RECEIVER/CONTROL WITH WHICH THIS DEVICE IS USED.

This device complies with Part 15 of the FCC rules and RSS210 of Industry Canada. Operation is subject to the following two conditions: (1) This device may not cause harmful interference, and (2) This device must accept any interference received, including interference that may cause undesired operation.

The user shall not make any changes or modifications to the equipment unless authorized by the Installation Instructions or User's Manual.

Honeywell

2 Corporate Center Drive, Melville, NY 11747

Copyright © 2007 Honeywell International Inc.

www.honeywell.com/security