

**Technical
Exhibit
Prospectus**



AAD
innovation
JULY 21-24, 2022 | VANCOUVER, BC | **ACADEMY**

Reserve your booth space today and join us for the **2022 AAD Innovation Academy!**

We are excited to offer your company the opportunity to reconnect in-person with dermatology experts and decision makers. To allow your team to focus on building brand awareness, we want to reassure you our priority is delivering a meeting that puts the safety and health of our attendees and exhibitors first. Safety protocols recommended by the CDC will be followed. The Vancouver Convention Center has been a leader in adopting COVID-19 precautions and is a Global Biorisk Advisory Council® (GBAC) STAR™ accredited facility. Visit aad.org/IA22 for the most up-to-date information.

Table of Contents:

- General Information 3
- Application and Selection Procedures 5
- Booth Construction 8
- Rules, Regulations and Guidelines..... 12
- Show Services 17
- Promotional, Sponsorship &
Advertising Opportunities 20
- Future AAD Meetings..... 22

ATTENTION EXHIBITORS

Important Dates & Deadlines

To facilitate your quick review, all important dates and deadlines are highlighted throughout the Technical Exhibit Prospectus.

 **IMPORTANT CHANGES**
New and/or revised rules are identified with this designation.

General Information

MEETING DATES

July 21-July 24, 2022

LOCATION

Vancouver Convention Centre
1055 Canada Pl, Vancouver, BC V6C 0C3

EXHIBITS & INDUSTRY PRODUCT

THEATER

Ballrooms C/D and Foyer

SCIENTIFIC SESSIONS

Levels 1 - 3

REGISTRATION

Level 1 Lobby

EXHIBIT SCHEDULE:

- ✓ **Registration of Technical Exhibitors**
 - Wednesday, July 20..... 8 a.m. – 5 p.m.
 - Thursday, July 21..... 8 a.m. – 5 p.m.
 - Friday, July 22..... 8 a.m. – 5 p.m.
 - Saturday, July 23..... 8 a.m. – 3:30 p.m.
- Installation of Exhibits**
 - Wednesday, July 20..... 8 a.m. – 5 p.m.
 - Thursday, July 21..... 8 a.m. – 12 p.m.
- ✓ **Exhibition Dates**
 - Friday, July 22..... 9 a.m. – 5 p.m.
 - Saturday, July 23..... 9 a.m. – 3:30 p.m.
- ✓ **Unopposed Exhibit Hours**
 - Friday and Saturday, July 22-23..... 12 p.m. – 1 p.m.
- Welcome Reception with Exhibitors**
 - Thursday, July 21..... 6 p.m. - 7:30 p.m.
- ✓ **Refreshment Breaks**
 - Friday & Saturday, July 22-23..... 3 p.m. – 3:30 p.m.
- ✓ **Dismantling of Exhibits**
 - Saturday, July 23..... 3:30 – 9 p.m.
 - Sunday, July 24..... 8 a.m. – 12 p.m.

IMPORTANT DATES TO REMEMBER

EXHIBIT SPACE SELECTION..... April 27, 2022

SPACE CONFIRMATIONS / INVOICES SENT..... May 4, 2022

FULL OR FINAL BOOTH PAYMENT DUE..... June 8, 2022

SPACE CANCELLATIONS / REDUCTIONS

Full Refund.....by June 8, 2022

No Refunds.....After June 8, 2022

REGISTRATION, HOUSING, & BADGES May 2022

EXHIBITOR RESOURCES: Housing Forms & Registration information,
Exhibitor Services, & advertising opportunities available May 2022

For More Information Contact

Sara J. Peterson, CEM Senior Manager,
Exhibitions & Meeting Services
American Academy of Dermatology
9500 W Bryn Mawr Avenue, Ste 500,
Rosemont, IL 60018-5216

Phone: (866) 503-SKIN (7546)
Fax: (847) 330-1090
E-mail: exhibits@aad.org
Website: www.aad.org

**2021 Summer Academy Meeting Attendance
(Tampa, FL)**

Member	602
Life Member	14
Honorary Member	15
Dermatology Resident/Medical Fellow	198
Non-Dermatology Resident/Medical Fellow.....	1
Medical Student	45
Non-Member Physician.....	122
Non DCT nurse (RN/LPN)	4
Non DCT Physician Assistant.....	22
DCT Physician Assistant (new AM16).....	6
Non DCT Nurse Practitioner	21
DCT Nurse Practitioner (new AM16)	6
DCT Nurse (RN/LPN) (new AM16).....	0
DCT Medical Assistant (new AM16).....	0
Total Medical Personnel.....	1056
*Dermatology Practice Staff.....	22
Non-Member Non-Physician.....	203
Adjunct Member (researcher/corporate)"	11
Adjunct Member (other)	0
Total Non-Medical Personnel	236
Total Guest	N/A
Exhibitors (Free)	593
Exhibitors (Paid).....	142
Total Exhibitors	735
Total Press.....	N/A
GRAND TOTAL.....	2027

Included in the 1,056 Medical Registrants above are 213 Medical Registrants (Physicians, Residents, Students, and Medical Staff), from countries outside the United States.

The top 10 countries in order of medical registration are as follows:

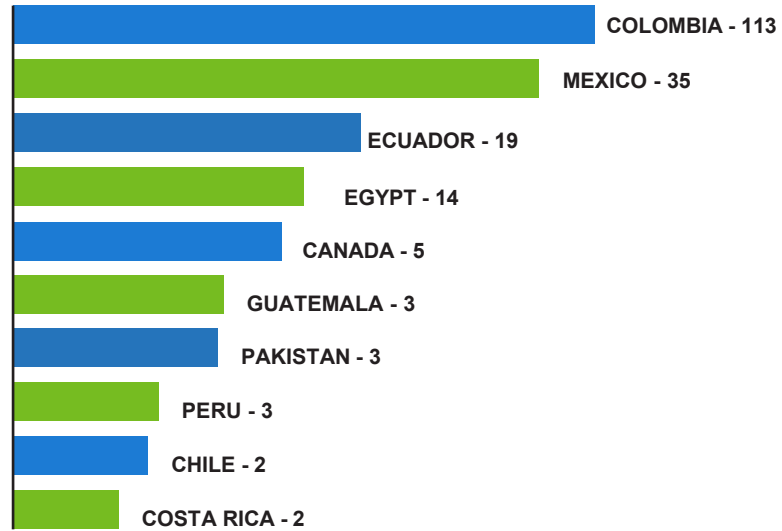

Application & Selection Procedures

Categories of Exhibits

The Academy will consider applications for exhibit space for products or services in the following categories:

- Pharmaceuticals (both prescription and nonprescription)¹
- Equipment and devices designed for diagnosis or treatment of dermatologic conditions²
- Cosmetics and skin care³
- Scientific/medical educational publications
- Activities of professional and educational organizations
- Products or services relating to the support of non-medical aspects of the practice of dermatology (office equipment, record keeping equipment or services, etc.)
- Physician recruitment and placement services*
- Research survey activities, in conjunction with confirmed exhibiting companies*

All exhibits are to be designed in such a manner that the presentation of products and services in the exhibit hall will enhance the overall educational goals of the Meeting.

*Please note that the amount of space available for the exhibition of products or services in any category will be subject to special limitations or complete elimination, as determined by the Academy, depending upon the availability of space to accommodate exhibits of scientific educational value.

1 FDA Division of Drug Marketing, Human Drug Information, Division of Drug Information (CDER) Office of Communications

2 FDA Office of Compliance, CDRH-Center for Devices and Radiological Health

3 FDA Center for Food Safety and Applied Nutrition (CFSAN)

Evaluation of Exhibit Application/Contract

In order to preserve and maximize the educational value of the technical exhibit program, the Academy will examine each Exhibit Application/Contract ("Application") and evaluate the applicants to determine whether they satisfy the Academy's exhibitor eligibility criteria and other requirements set forth herein.

Permission to exhibit does not constitute in any way an Academy endorsement or approval of the exhibited products or services, or guarantee that space will be assigned.

The examination and evaluation of Applications will be performed by the Academy in accordance with guidelines herein. The decisions of the Academy regarding applications shall be final. The principle criteria to be considered by the Academy include, but are not limited to, whether the products or services proposed for exhibition relate specifically to the practice and advancement of dermatology, or the education of the dermatologist and their patients.

AAD reserves the right to refuse space to any company that has failed to fulfill its financial obligations to AAD, and/or whose products or services, in the sole judgment of AAD, do not meet the educational, scientific or practice needs of our Fellows and members.

Applicants who have either never exhibited at an Academy live or virtual Meeting or have not exhibited in the past three years must complete the review process, prior to assignment of exhibit space.

New Applicant Submission Requirements

- A properly completed exhibit space application.
- Company profile. The information should include a copy of the company's filed Articles of Incorporation or W9, company history, mission statement, management team bios, and advisory/board of directors listing if applicable
- The products and/or services the company plans to exhibit (i.e. product brochures or literature)
- Documentation of FDA filing status (if applicable) or acknowledgement of compliance with FDA policies
- Exhibitors must disclose details on any consumer, commercial, intellectual property, or government litigation, prosecutions, orders, injunctions, judgments or settlements over the last three years regarding the business practices of the company or the products and services to be exhibited. Companies with multiple complaints filed against them with state or federal consumer affairs regulatory agencies, the Better Business Bureau, or Academy members may be required to provide an explanation of the resolution of those complaints.

Application Procedures for Established Exhibitors

An applicant that has previously exhibited must complete the review process only if there has been a material change in circumstances relating to its company (e.g., a change in ownership, control, or legal status) or in the nature, name, composition, products, labeling, or regulatory status of the products and services to be exhibited.

Exhibitors must disclose details on any consumer or government litigation, orders, injunctions, judgments or settlements over the last three years regarding the business practices of the company or the products and services to be exhibited. Companies with multiple complaints filed against them with state or federal consumer affairs regulatory agencies, the Better Business Bureau, or Academy members may be required to provide an explanation of the resolution of those complaints.

Exhibitors utilizing the services of a third party to contract for exhibit space and services must provide written authorization on Company Letterhead indicating the name and contact information of the authorized third party. This documentation should accompany the application for space or emailed to exhibits@aad.org.

In order to be considered for the first selection of exhibit space, Space Applications/Contracts must be received online at the Academy office by March 30, 2022. Applications received after March 30 regardless of the company's priority point status, will be assigned on a first-come, first-served basis following the completion of the initial space selections.

General Application Policies

The Space Application/Contract must include a list of all product categories that will be exhibited at the 2022 Innovation Academy Meeting. Complete descriptive information must accompany the Space Application/Contract. The Product Category section on the Space Application/Contract must be completed.

All acceptances of Space Applications/Contracts and assignments of exhibit space are conditioned upon continued compliance of the products or services proposed for exhibition with the basic criteria established for technical exhibits. If at any time a product or service for which a Space Application/ Contract has been accepted fails to conform to such basic criteria, the Academy may revoke its acceptance of the application and all exhibit space rental fees paid to date by the applicant may be refunded in accordance with Academy's refund policy, and the Academy shall have no further liability to the applicant with respect to the proposed exhibition. Similarly, the Academy, on the basis of new information, will impose such additional conditions on an exhibitor as deemed necessary to assure that such exhibit satisfies the basic criteria for technical exhibits.

Applications from companies that have outstanding balances due the Academy, its contractors, or vendors will not be processed without full payment of delinquent accounts.

Successfully completing the Exhibit application or the Exhibit Review Process does not guarantee that you will be assigned booth space. The Academy meetings consistently sell out of exhibit space and maintain waiting lists. Academy exhibit space is selected in priority point order by exhibitors that have a history of exhibiting at the Academy meetings.

Notwithstanding the foregoing, The Academy and Exhibitor agree that Exhibitor shall have the right to disclose publicly the existence of this agreement, the terms and conditions of this agreement, description of services, amount of payment and any other disclosures as required by law.

Code of Conduct

The American Academy of Dermatology (AAD/Academy) expects all meeting attendees to maintain high standards of professional conduct and uphold the policies and procedures set forth for the meeting. The Code of conduct is available at: www.aad.org

Selecting Your Preferred Spaces

The following information will assist exhibiting companies with less than ten (10) years of exhibiting experience with the Academy to increase their chance of securing their preferred booth location.

Because exhibit space is selected under a priority point system, and the fact that many companies have exhibited annually for many years, it is unlikely that a company that has exhibited for only a few years or is new to the Academy would be able to obtain a booth at or near the entrances to the exhibit halls. Therefore, if you have less than ten (10) years of exhibit experience in the show, it would be to your advantage to plan your booth selections with this information in mind in order to maximize the chance of securing your preferred space.

Selection of Booth Space

The first selections of space under the priority point system will be begin April 27, 2022. Exhibitors will receive email notification of their space selection date and time by April 13, 2022. Selection times are based upon accrued priority points. Priority points are determined by:

- Participation of an applicant in the 2021 AAD Innovation Academy technical exhibit programs.
- Amount of exhibit space for which an applicant was assigned in prior meetings.
- Financial contributions of the applicant to the educational programs of the Academy.

Remaining space will be available on first-come, first-serve basis, and will be assigned within 10 business days of receipt of the application. In the event exhibit space for the 2022 Innovation Academy Meeting is sold out, companies will automatically be placed on a waiting list. As long as space is available, the Academy will continue to make space assignments on a periodic basis until June 17, 2022. All space assignments are subject to the cancellation policy deadlines, regardless of the date space was assigned.

The Academy reserves the right to rearrange the floor plan at any time. The Academy reserves the right to relocate exhibitors should it become necessary for causes beyond the control of the Academy, or advisable in the best judgment of the Academy.

After assignment of space, exhibitor agrees to accept relocation to other comparable space if the Academy deems such a relocation to be necessary or appropriate. Because space may not be available to accommodate all qualified applicants, the Academy may have to select among qualified applicants in granting permission to exhibit.

AAD reserves the right to place reasonable limitations on the number of booths to be rented to any exhibitor. The limitation will be determined by the relation of total applications to the number of booths available on the floor plan. The AAD strives to provide a broad spectrum of products and services.

The Academy will attempt to accommodate exhibitor requests for specific booth(s); however, no guarantees can be made that the Exhibitor will be assigned the specific booth(s) requested. The Exhibitor acknowledges that he/she is not contracting for a specific booth(s), but rather for the right to participate in the meeting.

Multiple Divisions

Companies may choose to average priority points in order to be grouped together in the space selection process. The process will allow divisions to contract separately while maintaining their own identities, i.e. exhibits, exhibit listings, badges, etc. Each corporate division must notify the Academy, exhibits@aad.org, in writing by March 30, 2022, of their desire to be grouped together with other divisions.

Mergers, Acquisitions, Spin-Offs

Companies that have merged with, been purchased by, or have purchased another company may use the exhibit history from company alone, whichever is more favorable, but not the combined history of both companies. The Academy should be notified in writing by both companies' that the acquisition or merger between companies has been completed and list the date of completion.

Companies requesting a transfer of points must be "directly related" to an exhibiting company in order to inherit those points. A "directly related" company shall be defined as a company that is wholly owned by, is a controlling owner of or has merged with another company. All requests for transfer of points must be submitted in writing to the Academy Exhibit Manager and confirmed in writing by the parent or subsidiary company.

A company restructure that results in a newly formed independent business (spin-off) may use the exhibit history of the parent company. The Academy should be notified, in writing, that the restructure (spin-off) has been completed. If the parent company is relinquishing the exhibit space to a spin-off company, the parent company must cancel the contract with the Academy, and the spin-off company must submit a new application/contract for space. In this case, the Academy will issue a refund to the parent company, pursuant to cancellation policies, and the full exhibit space payment will become the responsibility of the spin-off company.

Deposit & Payment Information

Booth Fees

\$38.00 per square foot

The price of the booth includes the following:

- Company listing published online and the mobile app.
- Four (4) exhibitor badges per 100 square feet of booth space
- The exhibitor badge allows admittance to the exhibit hall only. Full meeting registration, in an appropriate alternate registration category, is required in order to attend scientific sessions.
- Access to advertising & sponsorship opportunities
- Access to AAD housing rates, and authorization to request meeting space in AAD designated hotels.
- A two-line identification sign (7" x 44") showing company name and booth number (if ordered in advance from the service contractor).

Payment

An Invoice for full payment will be sent after space has been assigned.

Space must be fully paid for by June 8, 2022. No company will be permitted to exhibit unless full payment for booth space has been received. Booth payments should be made payable to the American Academy of Dermatology and sent to the address indicated. Late payments will be assessed a fee of 3% of the outstanding balance.

Applications received after June 8, 2022 require the total booth fee due within 5 business day of receiving the space confirmation.

No application will be processed or space assigned until any outstanding accounts with the Academy are paid in full. The acceptance by the Academy of a deposit with an application does not in any way constitute acceptance of the Application or grant permission to exhibit.

Payment must be by a check in U.S. funds drawn on a U.S. institution or online by credit card only to American Academy of Dermatology.

United States Postal Service, UPS and Express Mail, Federal Express Address:

American Academy of Dermatology
ATTN: Meetings & Conventions Department
9500 W Bryn Mawr Ave, Ste 500, Rosemont, IL 60018

The Academy bears no liability for any application that is not received through the address listed above or for any incomplete submission via the online application site.

Late Payment

Late payments will be assessed a fee of 3% of the outstanding balance.

Exhibitor Directed Space Cancellations/Reductions

Notification of an exhibitor's decision to cancel or reduce space must be sent in writing on company letterhead to the Academy Exhibit Manager at the Academy office via certified mail (return receipt requested). The date of cancellation shall be the date that the Academy received the written cancellation. If an exhibiting company does not cancel their space in writing and does not occupy their booth space on-site, the company will be liable for 100% of the cancellation fees, automatically forfeit all priority points and may not be permitted to participate at future Academy meetings.

If written notification of cancellation or booth reduction is received at the Academy office:

Full Refund by June 8, 2022

No RefundsAfter June 8, 2022

Cancellation fees are remuneration for losses incurred by the Academy and are non-transferable. An exhibitor's cancellation of technical exhibit space will result in the release by the Academy office of any hotel/convention center public meeting space previously assigned to the exhibitor and all sleeping rooms assigned to the exhibitor.

Booth Construction Information

Size Configuration

Standard booths are 10'x10', arranged in a linear configuration

Every effort will be made to assign booths of the same type as requested. However, this cannot be guaranteed. All dimensions are believed to be accurate but are not warranted by the Academy.

Exposed or unfinished sides or exhibit backgrounds must be draped to present an attractive appearance. The exhibits will be inspected during the setup time and the service contractor, with the approval of the Academy, will provide masking drape as deemed necessary. Any charges incurred will be the responsibility of the exhibitor.

During the course of the installation and exhibit days, all booths are subject to on-site review. The Academy reserves the right to request modifications where necessary at the exhibitor's expense to ensure compliance with construction rules and regulations.

Linear Booths

Linear booths are 10' x 10' (100 square feet) or multiples thereof and are arranged in a straight line.

- All linear booths consist of 8'3" high backdrape and 4'0" high side dividers mounted on aluminum tubular frames.
- Exhibit fixtures, components and identification signs will be permitted to a maximum height of 8'3" (2.5m).
- Display material for linear booths is restricted to a maximum height of 4'0" (1.22m) in the front 5' (1.52m) of the booth, and 8'3" (2.5m) in the rear 5' (1.52m) of the booth.
- To maintain uniformity and to prevent obstruction of view of adjoining booths, no solid or draped walls can be higher than 8'3" in the back and 4'0" along the dividers and aisles, within 10 lineal feet of a neighboring exhibit.

10' X 10" LINEAR BOOTH

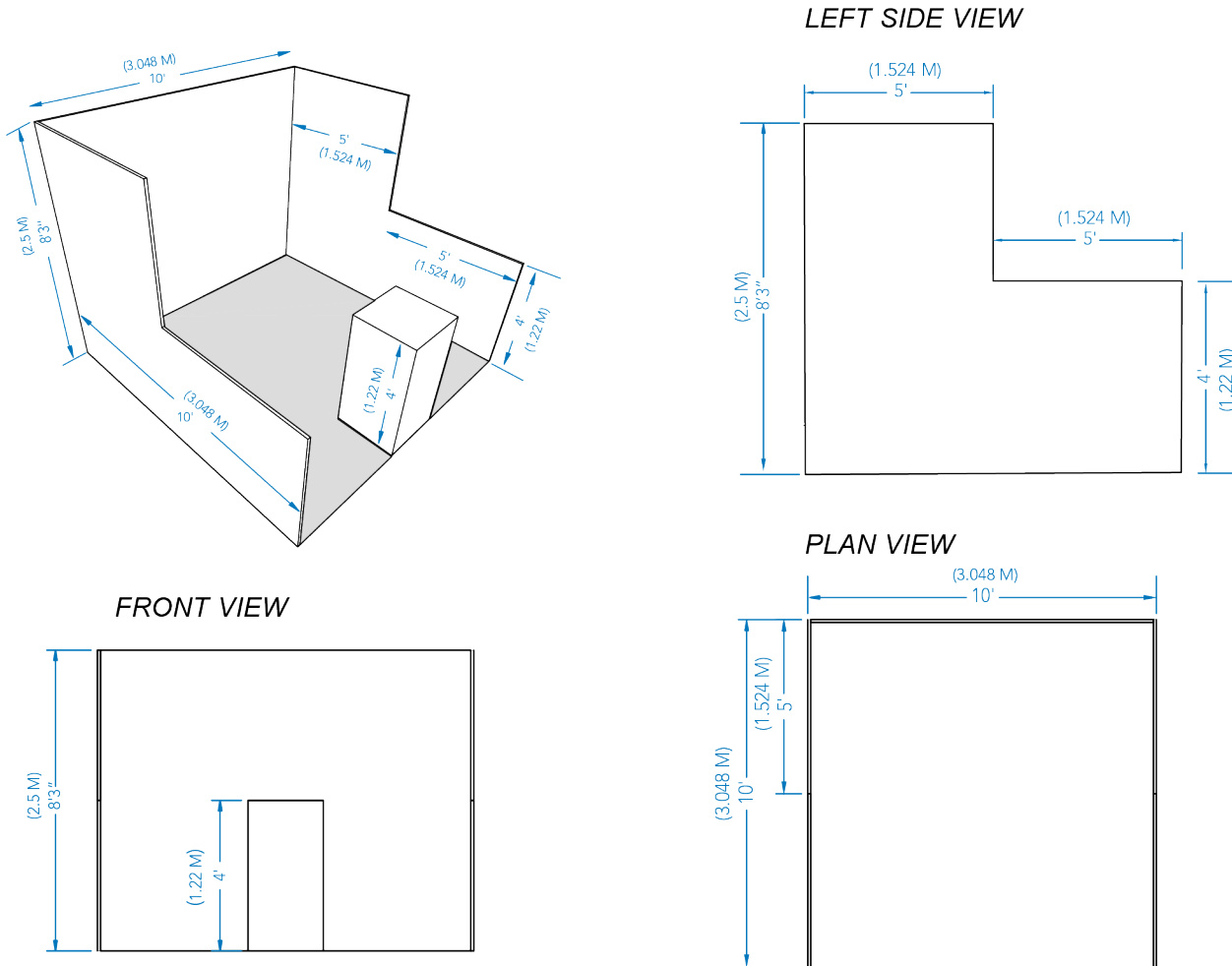



Canopies/Ceilings

The use of canopies in linear booths is prohibited.

Raised Flooring

Raised floors used in booths must be ADA compliant.

The flooring edge should be tapered down to the exhibit hall aisle. Corners on aisles should be rounded or protected.

Americans with Disabilities Act

Each exhibitor shall be responsible for compliance with the Americans with Disabilities Act of 1992 (ADA) with regard to their booth space, including, but not limited to, the wheelchair access provisions.

Aisle Space

The main aisles of the exhibit area are for the exclusive use of the Academy. Exhibitors are not permitted to purchase designated aisle space. The aisles will be vacuumed daily by the Academy.

Booth Carpet and Booth Cleaning

The exhibit hall is carpeted. Exhibitors may choose to bring their own carpeting or rent it from the service contractor. Exhibitors are not permitted to carpet outside their assigned exhibit space. Exhibitors are required to keep their booths clean at all times. The Academy has the right to order daily cleaning if booth appearance is unsightly. Any costs for this cleaning will be charged to the exhibiting firm.

Lighting and Electrical Requirements

Sufficient light is provided for adequate general illumination of the exhibit area., Exhibitors are not permitted to have exhibit hall lighting dimmed or turned off above their booth space. No individual electrical outlets are provided in the booth space. All electrical service must be supplied by facility electricians to ensure that it will meet safety requirements of the fire regulations of Vancouver.

Overhead Signs / Banners / Lighting Truss

Hanging signs/truss are not permitted. Exhibitor lighting must be limited to the confines of the booth space. Lighting that projects onto another exhibitor's space or Academy aisles or otherwise detracts from the professional atmosphere of the event will not be permitted

Balloons

The use of balloons as part of the exhibit display or as a giveaway is prohibited.

Facility Fire/Safety Guidelines

The Vancouver Convention Center has established guidelines regarding acceptable booth configuration from a safety standpoint. It is the responsibility of each exhibitor to ensure compliance with all Facility Regulations. Facility Regulations related to exhibit booths are available at the Online Exhibitor Services Store, available in May 2022.

Rules, Regulations & Guidelines

General Promotional Guidelines

Right of Refusal

The Academy reserves the right to reject requests for promotions, or not to renew previously approved promotions, at any time, for any reason, or no reason at all. Promotions that conflict, or have the appearance of conflicting, with Academy policy are prohibited.

Endorsement

The Academy's acceptance of promotion is not intended to convey Academy approval, endorsement, certification, acceptance, or referral of any particular organization, or any product or service manufactured or distributed by that organization. Promotion permitted in Academy communications vehicles is not to be construed or publicized as an endorsement or approval by the Academy, nor may the promoter state that its claims are approved or endorsed by the Academy. The fact that a promotion for an organization, a product, or a service has appeared in an Academy-sponsored communications vehicle, shall not be referred to in collateral advertising or literature by that organization.

Comparisons

Comparison to the Academy's products or services is prohibited. Comparison to a competitor's products or services is permitted if claims of superiority have not been challenged by the FDA or FTC and data from well-controlled clinical studies cited in recognized, peer-reviewed medical journals, are cited in the ad and can be made available to the Advertising Review Team upon request.

Comparisons to a competitor's products or services may not be disparaging, false or misleading. The Academy requires that advertisers affirmatively attest in writing that they are in compliance with FDA and FTC guidelines on comparative advertising and/or that they have met the standards of the FDA/FTC.

Competition

Promotion of products, meetings, and services that compete directly with those offered by the Academy is generally prohibited. Membership solicitation by organizations other than the Academy and the members of the Intersociety Liaison Committee and state dermatology societies, which have established reciprocal agreements, is prohibited. Fundraising by organizations or individuals other than the Academy is strictly prohibited.

Display of Non-Academy Corporate Recognition

The display of corporate recognition from organizations other than the American Academy of Dermatology is generally discouraged. The Academy will permit exhibitors to display one table-top sign per organization. The size of the sign must be smaller than 5" x 7".

Propriety

Promotions deemed by the Academy, in its sole judgment, to be indecent, offensive or otherwise inappropriate in content are prohibited.

Interpretation and Application of Guidelines

All matters and questions not specifically covered by these Guidelines, or other specific Academy guidelines, are subject to the final decision of the Assistant Secretary-Treasurer of the Academy.

Termination

The Academy reserves the right to terminate any promotion that could reasonably be determined to affect adversely the goodwill or reputation of the Academy or its affiliates.

Violations

Specific actions may be taken by the Academy for violation of any provision of these guidelines. Violations of any Academy policies, guidelines, rules or regulations may result in the loss of priority points for future space assignments and/or immediate removal from the exhibit hall and/or denial of exhibit space at future meetings. The action taken will be determined on the basis of the particular circumstances of the violations, but in cases involving major violations, may include legal action.

Advertising

Exhibitors must abide by Academy Advertising Standards. Refer to Academy Advertising Standards available at www.aad.org/ meetings.

Exhibit items, advertising literature or pamphlets that are distributed may contain only recognized indications and claims. Advertising in any media that particular products or services have been exhibited at the 2021 AAD Innovation Academy or in a manner that could be construed as an endorsement by the Academy or by its members is prohibited.

With the exception of the Academy approved recognition programs, Academy logos, seals, trademarks, service marks, or other similar property rights, including those that are in disuse, may not be used in connection with any product or advertising materials displayed or distributed.

Exhibitors shall not transmit or permit anyone to transmit any part of the 2022 Innovation Academy Meeting by means of radio, television, cable, videotape or other method of transmission of aural or visual reports. Exhibitors may not reference any part of the Academy Scientific program in any of their exhibit marketing materials or within their exhibit booth.

Advertising materials, other than official Academy advertising programs, may not be distributed outside the exhibitor's booth. This applies to distributing flyers, handbills, invitations, magazines or other advertising materials to hotel rooms of 2021 AAD Innovation Academy attendees. Canvassing or distributing materials on the property or grounds of the convention center or hotels used by the Academy during the Academy Meeting is prohibited.

Photography, Video Recording, Streaming Video

Due to the sensitive scientific nature of many products or services displayed within the technical exhibit hall, the Academy enforces strict policies regarding photography and videography as follows:

- Photography, Videography/Streaming Video is only permitted under the following conditions:
 - Exhibiting companies are required to use the AAD official photographer/videographer, or their own full time staff (no contractors)
 - Exhibitors may only photograph/videotape within the confines of their own contracted exhibit or meeting space.
 - Exhibitors may not photograph another company's exhibit booth, personnel or activities, or any other areas of the exhibit hall or AAD meeting space/venue.
- Exhibitors are prohibited from inviting outside photographers or videographers onto the exhibit floor to document their booth and/or their products or services. Anyone with a camera or recording device attempting to gain access to the exhibit floor will be denied entry. This includes non-registered staff from the exhibitor's company, local broadcast media or public relations staff under contract with the exhibitor.
- Conference attendees may take photographs during oral or poster presentations provided that the photographs are strictly for personal, noncommercial use and are not to be published in any form. Attendees are prohibited from using flash photography or otherwise distracting the presenters or members of the audience.

Attendees will be required to sign an attestation during registration stipulating that they agree that the photos will only be used for personal, non-commercial use. Speakers may use watermarks or include text on slides to indicate personal copyright of images.

The AAD Meetings are wholly owned by the Academy and not public events. Programs presented at the AAD Meetings are for the education of attendees and purchasers of recorded presentations as authorized by the Academy. Any unauthorized use of program content, the name of an Academy speaker and/or program title, or the name of Academy without the written consent of the Academy is prohibited and will be grounds for termination of exhibitor privileges and prosecution for infringement of the copyright laws.

For purposes of the preceding sentence, 'program content' includes, but is not limited to, oral presentations, audiovisual materials used by speakers and program papers, outlines, other hand-outs, poster presentations and exhibition hall activities. This rule applies to unauthorized uses of Academy program content before, after and/or during the meeting.

Badges

All representatives of exhibiting firms must register and wear the official exhibitor's badge for admission to the exhibit hall and for the duration the exhibitor is in the exhibit hall. The company name that appears on the badge will be the name provided on the Space Application/Contract only. Company name changes will not be accepted on-site. Company badges will not be accepted in lieu of the official badge. Individuals who do not have badges will not be admitted into the exhibit area. Badges may not be altered or covered in any manner. Individuals found in violation may be asked to relinquish their badge and escorted from the exhibit hall.

Exhibit Booth Access

Exhibit personnel may not enter another exhibitor's booth without obtaining permission, nor may they conduct activities, which in the opinion of the Academy, impede another exhibitor's ability to conduct business. This is in respect of the rights of other exhibitors to conduct business during exhibit hours without interference or improper intervention. The Academy, its representatives, and employees, shall have free access to any exhibit at all times.

After-Hours Admission to Exhibit Hall

During show days, exhibitors wearing badges may enter the exhibit hall at 8 a.m. and may remain in the exhibit hall one half hour after the close of the exposition.

Orientation Meetings

Companies who wish to hold staff orientation meetings within the confines of their booth may do so two hours before the exhibit hall opens. Exhibit personnel must wear their badge in order to enter the hall for these meetings. Do not arrange meetings with physicians or individuals other than your booth personnel prior to the opening of the exhibit hall since they will not be permitted to enter. To gain admittance to the hall, all individuals must be badged.

Booth Activities

The exhibitor is permitted to demonstrate the firm's equipment, make informational presentations regarding the product line or service, and distribute product information and related product marketing activities from the exhibit booth. CME activities are not permitted in the Technical Exhibit Hall. Physicians may be badged as exhibitors and staff the booth, provided they are either full time employees or paid consultants of the exhibiting company.

Physicians are only permitted to conduct promotional presentations within the technical exhibit booths, or Product Sessions.

Physicians are required to disclose their relationship with the company/product, to the audience. Only such activities which, at the discretion of the Academy, are in keeping with the professional department of the technical exhibits program will be permitted.

Under no circumstances may exhibitor marketing activities take place outside the exhibit booth, whether in or around the Vancouver Convention Center, or the hotel properties during Academy program hours. Activities that interfere with normal traffic flow, infringe on other exhibits, or interfere with any meeting activities as determined by the Academy, are prohibited.

Demonstrations

Demonstration areas should be placed a minimum of 5 feet in from the aisles. Aisles may not be obstructed due to any activities within the booth. Exhibitors are responsible for monitoring attendance to prevent aisle congestion. Presentations will be limited or eliminated in situations where overflow becomes a problem. Exhibit personnel or devices may not operate outside the booth space assigned during the official meeting hours. This includes travel to and from the booth space assigned and to and from a company's multiple booths.

Product and service demonstrations may be conducted by professional presenters or models; however, demonstrations are to be straightforward, professional and non-combative in nature and must avoid excessive crowds, noise, heat or light. The display of offensive materials, as determined by Academy Assistant Secretary- Treasurer, will be prohibited.

The use of live animals and live subject demonstrations for the purpose of demonstrating techniques that involve equipment, devices, or prescription pharmaceuticals is prohibited. Cosmetics and non-prescription skin care products may be demonstrated.

Medical Devices may not be demonstrated on live subjects.

If you are planning to conduct a Simulation (equipment turned off), you may do so under the following conditions:

1. Equipment must remain off at all times
2. Prominent Signage must be present in the booth to indicate that the activity is a "Simulation Only" and that "Equipment is not operational". This will clearly inform attendees that you are in compliance with Academy rules and regulations.

Because the exhibition of experimental products or services, the efficacy of which may not yet have been fully determined or which may not yet be commercially available, may in some cases be of significant scientific educational value, the exhibition of such products or services may be permitted if the basic criteria for technical exhibits are satisfied. However, permission to exhibit such products or services shall be subject to the conditions that the products or services be clearly identified as such in the exhibit area, and that full documentation as to the extent and results of research conducted with respect to such products or services be available in the exhibit area for examination by any registrant at the meeting.

The exhibition of such experimental products and services must also be in accordance with all applicable Health Canada regulations, as discussed more fully under the Health Canada Regulation section of this prospectus, and the approval status on any such product or service must be disclosed to all registrants that visit the exhibitor's booth.

If there is any question/concern whether a booth activity fits within the Academy guidelines, it is recommended that the company submit the activity for approval by June 17, 2022.

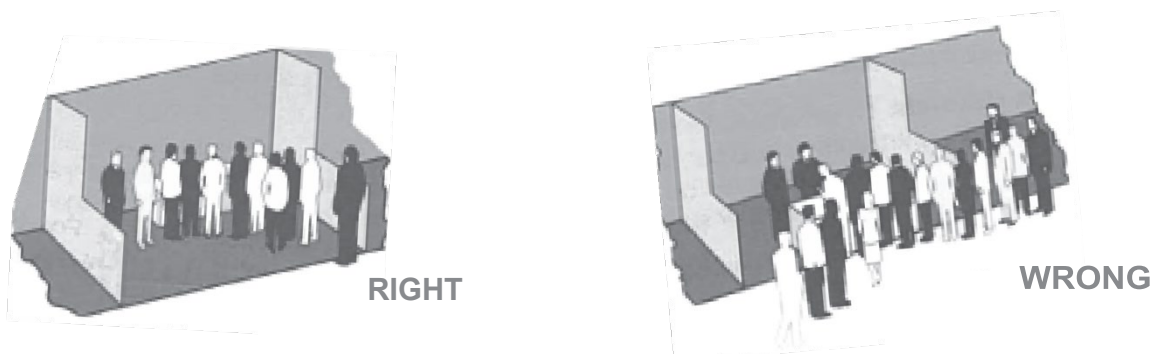

AV Equipment

The use of sound systems is permitted provided they do not interfere with the ability of neighboring exhibitors to conduct business activities. Any exhibit may be closed if deemed by the Academy, in its sole discretion, to have an excessive noise level. Exhibitors are responsible for obtaining appropriate licenses for any copyrighted music used in connection with their exhibit.

Health Canada Regulations

Exhibitors must abide by all applicable Health Canada regulations, including but not limited to any or all approval requirements. Exhibitors are reminded that the Health Canada generally prohibits the advertising or other promotion of investigational or unapproved drugs and devices.

If the Health Canada or a court of competent jurisdiction determines that a company's exhibit at an Academy meeting is in violation of any Health Canada regulations, including but not limited to the promotional restrictions and rules described above, the company must immediately cease exhibiting any offending products and may be subject to sanctions, including but not limited to exclusion from exhibiting at subsequent Academy meetings.

Concerns or questions regarding compliance with Health Canada regulations should be addressed as follows:

Marketed Health Products Directorate

Health Products and Food Branch

Health Canada

Office of Policy, Risk Advisory & Advertising

E-mail: hc.mhpd-dpsc.sc@canada.ca

Telephone: 613-954-6779

Facsimile: 613-948-7996

FDA, IFPMA, EFPIA and PhRMA Guidance

Exhibiting companies should consider systems to appropriately address the situation where health care providers (HCPs) view materials from countries other than their own, avoiding promotion directed to people not qualified to receive such content and promotion of unlicensed medicines and/or indications.

Explanatory Statements/Disclaimers As stated above, exhibiting companies should include a statement explaining to attendees when entering their booth/exhibit to help them understand the context by which the material was developed and to highlight that the content may not be applicable to their country.

Examples include:

- "You are viewing an International Congress run by [society name] and provided to international HCPs from around the world. Please note that prescribing information provided here may vary depending on local approval in each country.
- "The materials for [PRODUCT(S)] contained in this exhibition are approved for use only in [COUNTRY]. Prescribing information may vary depending on local approval in each country. Therefore, before prescribing any product, always refer to local materials such as the prescribing information and/or the Summary of Product Characteristics (SPC)."

Giveaways and Promotional Items

The Academy requests compliance with all applicable industry, state and federal regulatory and governmental agency guidelines (Health Canada, AMA, PhRMA, OIG, FDA, FCC, FTC, AdvaMed, etc...).

Acceptable giveaways should primarily entail a benefit to patients, be related to the physician's work, and should not be of substantial value.

The Academy, in its sole discretion, shall have the right to prohibit the distribution of any items it deems objectionable or otherwise inappropriate.

Booth Catering

Exhibitors will be permitted to distribute food and beverage items. Items must be ordered through the Vancouver Convention Center Catering Department, Aramark, the exclusive food and beverage provider. Catering information will be included in the Show Services E-Store.

Laser Precautions

In keeping with the recommended safety precautions for lasers, the Academy has adopted the following policies for laser exhibitors in the exhibit area:

- Lasers must be operated in a manner that is consistent with accepted industry safety standards (e.g., ANSI standards and/ or American Laser Institute standards). Under no circumstances may lasers be operated in a manner that poses a safety risk to persons standing or walking in the vicinity of the exhibitor's booth. The Academy reserves the right to determine whether a laser poses such a safety risk.
- Lasers must be operated only within a suitable enclosed space with eye protection for those viewing and operating the lasers.
- All demonstrations of CO lasers must be conducted in clear plastic boxes with all sides enclosed, including the top. Smoke evacuators must be used.
- Appropriate plastic colored cubicles must also be available for any other type of laser being used, including dye, KTP, diode, ND:YAG, alexandrite and ruby lasers.
- Appropriate eye and electrical protection must also be required for non-laser light source and radiofrequency devices.

The Academy Assistant Secretary-Treasurer may conduct random inspections of laser exhibitors during the course of the exhibition. Companies will be required to comply with any judgment related to safety concerns issued by the Assistant Secretary-Treasurer.

Failure to comply with these policies will result in the denial of the use of lasers in connection with the exhibit.

Selling and Order Taking

On-site sales are not permitted during Innovation Academy 2022.

Smoking

The 2022 Innovation Academy Meeting is a smoke-free environment. This applies to the entire Vancouver Convention Centre.

Staffing

As a courtesy to the physicians attending and to your fellow exhibitors, all exhibits must be open at the officially designated time each morning and staffed throughout each day of the meeting until the scheduled closing of exhibits at 5 p.m. on Saturday, August 7, 2021.

Subletting of Space

Subletting, sharing, allocation, partnering or any other similar arrangement of exhibit space is prohibited. An exhibitor may neither assign, allocate, nor apportion the whole or any part of exhibit space allotted, or display any goods other than those manufactured or distributed by the exhibitor in the regular course of the exhibitor's business, nor permit any representative of any other firm to solicit business or take orders in the exhibitor's space. The featuring of names or advertisements of non-exhibiting firms or businesses will not be permitted.

Surveys

All surveys must be conducted within the confines of the booth space assigned. At no time should exhibit personnel leave the booth to encourage attendees in the aisles to complete a questionnaire.

Exhibitor Meetings & Events

Academy approval, which may be granted or denied at the sole discretion of the Academy, is required for all exhibitor sponsored meetings and events during the 2022 Innovation Academy Meeting. Exhibitor-sponsored CME activities or subsequently produced CME activities are not permitted. Exhibitors planning to hold a meeting or event must submit the Exhibitor Function Request Form to the Academy.

Exhibitor meetings and events, involving medical personnel (physicians, residents, medical students, physician assistants, nurse practitioners, registered nurses and office staff), may not be scheduled during the Academy's educational and exhibit program hours. Meetings are permitted at the following times:

- Tuesday, July 19 All Day
- Wednesday, July 20 All Day
- Thursday, July 21 Before 7:15 a.m. and After 5 p.m.

Friday, July 22..... Before 7:15 a.m. and After 5 p.m.
Saturday, July 23 Before 7:15 a.m. and After 5 p.m.
Sunday, July 24..... Before 7:15 a.m. and After 12 p.m.

Exhibitor meetings and events, which do not involve medical personnel, may be scheduled during the following times:

Tuesday, July 19 All Day
Wednesday, July 20 All Day
Thursday, July 21 All Day
Friday, July 22..... Before 9 a.m. and After 5 p.m.
Saturday, July 23 Before 9 a.m. and After 5 p.m.
Sunday, July 24..... All Day

Hospitality Suites, Social Functions and other non-CME meetings may only be held by companies that are exhibiting at the 2022 Innovation Academy Meeting. Companies requesting a hotel suite for their functions should do so through the Academy Housing Service at the same time that sleeping room requests are made.

If there is any question/concern that an activity fits within the Academy guidelines, it is recommended that the company submit the activity for approval.

Specific actions may be taken by the Academy for violation of any provision of these guidelines. Violations of any Academy policies, guidelines, rules or regulations may result in the loss of priority points for future space assignments and/or immediate removal from the exhibit hall and/or denial of exhibit space at future meetings.

The action taken will be determined on the basis of the particular circumstances of the violations, but in cases involving major violations, may include legal action.

Data Privacy and Other Policies

The Academy's data privacy <https://www.aad.org/legal-notice>, and EU General Data Protection Regulations <https://www.aad.org/legal-notice/legal-eu>, and other policies for exhibitors are contained in the exhibitor Application and/or related registration materials and are incorporated herein by reference.

Interpretation and Application of Rules and Regulations

All matters and questions not specifically covered by these Rules and Regulations are subject to the decision of the Academy. Exhibitors agree to comply with all subsequent reasonable rules adopted by the Academy.

Insurance, Liability & Indemnification

Insurance

General liability insurance is mandatory for all exhibitors. Insurance protection will not be afforded to the exhibitor either by the Academy or by the Vancouver Convention Center.

Exhibitors shall carry their own insurance to cover exhibit material against damage and loss, and public liability insurance of at least \$1 million per occurrence and \$1 million aggregate, against injury to the person and property of others.

The exhibitor shall, at its sole cost and expense, procure and maintain through the terms of the contract for exhibit space, workers' compensation insurance in full compliance with all federal and state laws governing all of the exhibitor's employees engaged in the performance of any work for the exhibitor.

You must submit a certificate of insurance from your selected insurance carrier by June 17, 2022. Policies shall list the American Academy of Dermatology and the meeting venue as a named additional insured. Exhibitors should include in or have a rider attached to their insurance policies covering the period of time from the date of shipment, including the return/arrival date of the merchandise/display at the exhibitor's home base.

If you do not have proof of insurance, show management has negotiated a public liability insurance policy good for the 2022 Innovation Academy Meeting, July 21-24, 2022 that you may purchase through the official insurance provider, Rainprotection. Detailed information will be posted on the AAD website.

Limitation of Academy Liability

Except as specified below, if, after the Application is entered into, the Academy fails or is unable to provide an exhibitor with the opportunity to exhibit at the 2021 AAD Innovation Academy, and the exhibitor is not responsible for such failure, the exhibitor's sole

and exclusive remedy shall be the return of all monies that it has paid in connection with the Application/Contract. In such case, the Application/Contract between the Academy and the exhibitor shall automatically terminate, and the Academy shall bear no further liability or responsibility under such agreement.

Liability and Indemnification

The exhibitor will be fully responsible for any third-party claims, liabilities, losses, damages, or expenses relating to or arising out of any injury to any personnel of an exhibitor or to any other person or any loss of or damage to any property of an exhibitor or any other property where such injury, loss or damage is incident to, arises out of, or is in any way connected with the exhibitor's participation in the Academy technical exhibits program, and the exhibitor shall protect, indemnify, hold harmless and defend the Academy, its official directors, agents, members, servants, and employees from and against any and all such claims, liabilities, losses, damages and expenses, provided that the foregoing shall not apply to injury, loss or damage caused by or resulting from the negligence or willful misconduct of the Academy, its official directors, agents, members, or employees or the Vancouver Convention Center or its agents, servants or employees.

Exhibitor further waives any claim against the Academy, its official directors, agents, members, servants and employees, arising out of the oral or written publication or republication of any statement made in connection with the 2022 Innovation Academy Meeting by anyone not an employee of the Academy concerning the exhibitor or his/her exhibits, products or services.

Force Majeure

If, because of fire, strike, earthquake, war, construction or renovation projects affecting the Meeting venue, government regulation, public catastrophe, disease or epidemic, terrorism or the announcement by government authority of the possibility of terrorism, interruption of transportation or communications, Acts of God (including forecasted or actual severe weather), travel advisories by any governmental body or the World Health Organization, or any other circumstance or emergency beyond the control of the Academy, the event, or any part thereof, is prevented from being held or is canceled by the Academy, or any portion of the exhibit space becomes unavailable, the Academy in its sole discretion shall determine whether to refund to the Exhibitor no more than its proportionate share of the balance of the aggregate exhibitor fees received which remains after deducting expenses incurred by the Academy and taking into account the portion (if any) of the exhibit space that was or could have been occupied by the Exhibitor. In no case shall the amount of refund to Exhibitor exceed the amount of the exhibit fees paid. Exhibitor further understands that the Academy may in its sole discretion cancel the Event for reasons other than those stated above, in which case Exhibitor's sole remedy is a refund of any fees paid to the Academy.

Governing Law

Exhibitors agree that any disputes between the Academy and the exhibitor arising out of the exhibitor's participation in the 2022 Innovation Academy Meeting shall be brought in the courts, and shall be governed by the laws of the State of Illinois.

Show Services

Technical Exhibitor Personnel

Exhibitor Registration

The exhibitor's badge allows admittance to the exhibit hall only. No exhibitor will be admitted to the exhibit area without an exhibitor badge. Exhibitor badges are to be used for exhibiting company employees or agents who are staffing the booth.

Qualified exhibitor personnel, who wish to secure a seat in educational sessions and/or obtain CME/CE credit must register as a full conference professional attendee and pay the applicable registration fee. Attendee registration information is available at <http://www.aad.org/meetings/meetings>

Additional representatives over the allotment may be registered for a fee. No refunds will be issued for additional badges purchased and not used. Registration fees must be paid at the time of registration. Technical exhibitor registration instructions will be mailed to each exhibiting firm in May.

The exhibitor's badge allows admittance only to the exhibit hall. In order to avoid delays on-site, it is advisable to advance register booth personnel. Exhibitors not pre-registered by their company must register on an individual basis on-site. Those representatives registering on-site will be required to provide proof of company affiliation with the exhibiting company. Both photo identification and

proof of company affiliation are required. Exhibitor registration will be open during the following hours:

On-Site Registration

Companies that do not register their representatives by the advanced registration deadline may register on-site. Registration fees must be paid at time of registration. No refunds will be issued for additional badges purchased and not used. All onsite exhibitor staff will be required to show a business card with the exhibiting company name and a photo ID.

Wednesday, July 20..... 8 a.m. – 5 p.m.
Thursday, July 21..... 8 a.m. – 5 p.m.
Friday, July 22..... 8 a.m. – 5 p.m.
Saturday, July 23 8 a.m. – 5 p.m.

Before July 22, 2022:

Each representative over the company's allotment will be registered at a fee of \$50.00

July 22-23, 2022:

Each representative over the company's allotment will be registered at a fee of \$100.00 Name Changes or substitutions will be processed at a fee as listed below:

- Before July 22, 2022, \$50.00
- July 22-27, 2022, \$100.00

Replacement badges will be processed at a \$25.00 fee for the first reprint and subsequent reprints will be processed at a fee of \$100.00.

Once a badge has been printed it cannot be returned.

Exhibitor Registration Options

Mail In Advance Registration

Please refer to www.aad.org/meetings for specific deadline dates.

Receive your badges in advance and avoid long lines onsite by registering your booth personnel early. Just select the main in advance option when you verify your company information.

Once badges have been printed, name changes or substitutions will be processed onsite at a fee.

Badges requested online after mail in advance deadline listed on the website, will not be mailed and must be picked up onsite at exhibitor registration.

Continuous Registration – Will Call Pick-Up Only

If you do not choose to have your badges mailed in advance, you may continue to make additions and changes as long as the badge has not been printed. These badges will be available for pick up on site by the individual badge holder. Each individual will be required to present photo identification or their confirmation. All badges must be picked up individually.

Housing

Housing instructions will be emailed in May to each exhibiting company. Housing arrangements may be made online through the Academy web site starting in May at www.aad.org/meetings.

Travel

Travel information will be available on the AAD website in May at www.aad.org/meetings.

Parking

Public parking lots are available in the surrounding area. Street parking is generally not available and is not recommended due to highly restrictive parking ordinances.

Media Related Activity

The Academy's Press Kiosk is responsible solely for the extensive media activities conducted by the Academy, and does not interact with

technical exhibitor media matters. Exhibitor media materials may not be displayed/distributed in any location in the Vancouver Convention Center. Press registrants of the Academy have access to the technical exhibit hall during regular exhibit hours for reporting purposes only. Television cameras/film crews are not permitted in the technical Exhibit Hall. Filming and photographing the technical exhibits is prohibited.

Exhibitors may not conduct media events in the technical exhibit hall or convention center at any time during the meeting.

Media related activities occurring outside the convention center are permitted only during the following times.

Exhibitors planning to hold a media event must submit the Exhibitor Meeting & Event Request Form to the Academy.

Tuesday, July 19, 2022.....All Day

Wednesday, July 20, 2022All Day

Thursday, July 21, 2022 Before 7:15 a.m.

Friday, July 22, 2022 Before 7:15 a.m. and After 5 p.m.

Saturday, July 23, 2022 Before 7:15 a.m. and After 5 p.m.

Sunday, July 24, 2022 Before 7:15 a.m. and After 12 p.m.

Exhibitor media events may not be scheduled during the Academy's educational and exhibit program hours.

Meeting Rooms

The Academy utilizes the majority of the meeting space at the Vancouver Convention Center for official Academy programming; therefore, meeting space availability for exhibiting companies is very limited.

Companies planning an event may request approval for space, through the Academy, by completing and returning an Exhibitor Meeting and Event Request Form.

Once the event has been approved by the Academy, space requested at other venues will need to be secured independently.

Exhibitors will be notified of the status of their request within 10 business days after it has been received. The exhibitor will then work directly with a local venue to finalize all arrangements.

Only confirmed exhibitor functions and/or hospitality suites are permitted. (See Rules & Regulations – Exhibitor Meetings/Events).

Installation & Dismantling Information

Installation of Exhibits

Wednesday, July 20, 2022 8 a.m. – 5 p.m.

Thursday, July 2022 8 a.m. – 5 p.m.

All exhibit crates must be empty and tagged for storage no later than 3 p.m., Thursday, July 21.

All installation must be completed by 5 p.m., Thursday, July 21. Display space not claimed and occupied by 5 p.m. on Thursday, may be canceled or reassigned without notification or refund. If the exhibit is on hand, Academy reserves the right to:

If the exhibit is on hand, Academy reserves the right to:

- Assign labor to set up any display that is not in the process of being erected by 5 p.m., Thursday, July 21.
- Order the removal of all display materials and crates not in the process of being set up by 5 p.m., Thursday, July 21.

The charge for labor to complete either of these options will be billed to the exhibitor and the Academy shall have no liability for such work. Labor within the booth may be provided either through an exhibitor appointed contractor, the official service contractor or the Vancouver Convention Center. All individuals working in the hall must be badged. Infants and children under the age of 16 are not permitted on the exhibit floor at any time during installation and dismantling hours, during show hours, or before and/or after show hours.

Dismantling of Exhibits

Saturday, July 23..... 5 – 9 p.m.

Sunday, July 24 8 a.m. – 12 p.m.

Exhibits must not be disturbed, dismantled, or be in the process of being removed before 5 p.m. on Saturday, August 7, 2021.

Exhibitors dismantling before this time may lose earned priority points and forfeit their company's right to exhibit at future meetings of

the American Academy of Dermatology. All exhibit materials must be removed from the exhibit areas by 12 p.m. on Sunday, July 24, 2022.

If the exhibitor fails to remove their materials from the exhibit area in a timely fashion, the exhibitor shall indemnify, hold harmless and defend the Academy from and against any and all fees or expenses the Academy must pay to the Vancouver Convention Center as a result of such late removal. Any property remaining in the exhibit area after the termination of the 2021 AAD Innovation Academy may be disposed of or stored, at the exhibitor's sole cost, as the Vancouver Convention Center deems appropriate.

Official Contractor, Shipping & Services

Official General Service Contractor

General questions regarding any services should be directed to:

Freeman

Email: exhibitorsupport@freeman.com

Phone: 888-508-5054

Freeman and all other contractors listed in the Show Services E-Store act on their own behalf in all arrangements with exhibitors and are not agents, employees or representatives of the Academy.

All services or materials supplied by such contractors on order of the exhibitor will be billed directly by the contractor to the exhibitor. Therefore, the Academy does not assume liability or responsibility for any act performed or omitted by such official contractors, and the exhibitor agrees to look only to such official contractors in such event.

Official Drayage Contractor

Freeman has been designated as the official drayage contractor. The official contractor is responsible for maintaining all in and out traffic schedules at the show site and handling the move-in and move-out of all exhibitors' materials and equipment. Freeman maintains control and has priority at the loading areas at all times.

Advance Shipments — Warehouse

Advance shipments are made to the official drayage contractor's warehouse and will be received as many as 30 days in advance of the Meeting, stored and delivered to your exhibit space.

Direct Shipments — Vancouver Convention Center

Direct shipments are made directly to the Vancouver Convention Center loading dock for delivery to your booth and will be received beginning Wednesday, August 4, 2021. Shipments will not and cannot be received at the Vancouver Convention Center prior to Wednesday, August 4, 2021. Detailed shipping information will be included in the Exhibitor Service Kit.

Exhibitor Designated Contractors

If an exhibitor is planning to utilize an outside contractor, the Academy must receive written notification from the exhibiting company of the name, address and telephone number of its designated outside contractor and the name of the outside contractor's supervisor who will be responsible for on-site work in the exhibit area no later than June 17, 2022. A Non-Official Contractor form will be included in the Show Services E-Store. Notice from the contractor shall not be considered sufficient evidence of the contractual relationship between the Service Company and exhibitor.

Exhibitor designated contractors shall carry their own insurance to cover exhibit material against damage and loss, and public liability insurance of at least \$1 million per occurrence and \$1 million aggregate, against injury to the person and property of others.

The exhibitor designated contractor shall, at its sole cost and expense, procure and maintain through the terms of the contract for exhibit space, workers' compensation insurance in full compliance with all federal and state laws governing all of the exhibitor's employees engaged in the performance of any work for the exhibitor designated contractor. Policies shall list the Academy as a named additional insured. Exhibitor designated contractors must submit a certificate of insurance to the Academy office and the General Service Contractor by June 17, 2022.

Exhibitor designated contractors providing services at the 2022 Innovation Academy Meeting are subject to any and all rules imposed by the Vancouver Convention Center and the Academy. Service desks of any sort (including use of crates, stacks of ladders, gang boxes, etc.) will not, under any circumstances, be permitted in the aisles. Exhibitor designated contractors must not engage in the solicitation of business on the exhibit floor for present or future conventions. In order to protect the security of the exhibit hall, exhibitor designated contractors will not be permitted in the exhibit hall before or after designated exhibit hall access hours.

Work Passes

Unregistered exhibitor personnel and exhibitor designated contractors who would like access to the exhibit floor during installation and

dismantling hours will be required to show proof of affiliation with the exhibiting company or exhibitor designated contractor to receive a work pass. Work passes will be available through the labor check-in desk near the General Contractor Service Center. Work passes are not valid during show hours. Individuals will be asked to leave the floor and register as a technical exhibitor for a specific exhibiting company.

Exhibitor Service Information

The Show Services E-Store contains all of the forms and information necessary for ordering labor and services at 2022 Innovation Academy Meeting. The manual will contain order forms for services such as rental furnishings, booth carpet, labor, signage, plumbing, floral, audiovisual, telephone.

Exhibitor Service Center

A service center located in the exhibit hall and staffed by representatives of all official contractors will be open on Wednesday, July 20- Sunday, July 24, 2022.

Exhibit Hall Lighting

Half Lighting will be provided during official setup and dismantling hours. During the meeting, lighting will be provided one hour before the opening of the exhibit hall until the close of the exhibits each day. Exhibitors are not permitted to have exhibit hall lighting dimmed or turned off.

Security

Exhibitors are responsible for safeguarding their goods, materials, equipment and exhibits at all times. General guard service will be provided by the Academy for the exhibition period to monitor exhibit hall access points, but neither the guard service, the Tampa Convention Center nor the Academy will be responsible for the loss of or damage to any property. The Academy strongly encourages exhibitors to provide their own booth security.

Storage

Combustible/flammable materials such as brochures, literature, giveaways, etc. within exhibit booths are limited to a one-day supply. Nothing may be stored behind booths including packing containers, carrying cases, etc. A limited amount of product storage space will be available on the exhibit floor. Reservations to secure a portion of this space must be made in advance to the General Service Contractor. Storage reservation forms will be included in your Show Services E-Store. Availability is limited and will be confirmed on a first come/ first served basis and charged by the cubic foot. All other exhibit materials must be stored inside the exhibit booth.

Promotional, Sponsorship & Advertising Opportunities

Promotional Opportunities

Promotional Banners & Signage

Showcase your company's products and services in high profile locations throughout the Vancouver Convention Center. Information will be available online in May 2022.

Exhibit Hall Industry Product Sessions

Theater setting in the Technical Exhibit Hall offers exhibitors an opportunity to:

- Present new research findings on products
- Showcase product details and demonstrations
- Highlight new products to an interested audience

Sessions are available exclusively to confirmed exhibitors of the 2021 AAD Innovation Academy. The order form will be available online in May 2022.

Digital Booth Enhancement

2022 Innovation Academy Meeting Exhibitor Profiles are the most complete and up-to-date resource for exhibitors and product information. You can increase your visibility, showcase your products and drive more traffic to your booth by upgrading your exhibitor profiles. Go from basic to great! Please email Kristinem@expocad.com for information.

Registration Mailing Lists

The Academy provides advance and post meeting registration lists. The lists are available for rental for a one-time use only basis. This offer is available exclusively to confirmed exhibitors of the 2022 Innovation Academy Meeting. The order form will be available online in May 2022

Membership Mailing Lists

The Academy's membership list is more current and accurate than any other dermatology list available in the market. The Academy membership database is updated daily and we are able to provide data sorted in a number of ways. Because of this, Academy lists are widely utilized by both major medical publishers and pharmaceutical companies. For more specific details on your desired sort (counts, geographic breakdowns, custom sorting capabilities, etc.), cost information, or other questions, please contact:

Tina Matillano

Phone: (847) 240-1344

e-mail: mailinglist@aad.org

Distribution of Academy Member Information

The Academy rents its membership mailing list, which includes mailing addresses only, in accordance with these and other, more specific guidelines. The Academy does not rent or otherwise disseminate other member information, including but not limited to e-mail addresses and fax numbers, to other organizations.

Educational Support & Sponsorship of Official 2022 Innovation Academy Meeting Activities

The American Academy of Dermatology and Association (AAD/A) seeks to promote leadership in dermatology and excellence in patient care through education, research and advocacy. In meeting these objectives, AAD/A seeks to collaborate with corporate supporters and recognizes that corporate support is important to fulfilling its mission-related initiatives. The AAD/A welcomes support for programs, including:

- Academy-sponsored educational programs
- Public education initiatives
- Web-based activities
- Services and activities associated with the 2022 Innovation Academy Meeting.

Recognition of support is given through listings in the Program Book and other Academy publications, on meter boards and on its web site.

For further information regarding areas of educational support and/or industry sponsorship, you may contact:

Maureen Fishback

Manager, Corporate and Foundation Relations

American Academy of Dermatology

9500 W. Bryn Mawr Avenue, Suite 500

Rosemont, IL 60018-5216

Phone: (847) 240-1437

E-mail: mfishback@aad.org

Advertising Opportunities

The AAD offers several advertising programs in conjunction with the Annual Meeting, which are designed to help you maximize your exhibit investment. Advertising space sells out quickly, so please be Maximize your booth space and gain one-on-one face time with experts and key decision makers in the dermatology field to develop relationships, gain insight on emerging trends, and increase sales.

Digital Booth Enhancement

The Academy's Meeting Web Site is the showcase for attendees to access the latest meeting and exhibition information. Enhance your company's web presence, and showcase your products with an upgrade to your standard business card listing. Digital booths may be updated as often as you wish with show specials and highlights. Please email Kristinem@expocad.com for information.

Convention Center Advertising

Get unmatched visibility for your product messaging throughout the Convention Center.

Banners, digital media, and more! Detailed information will be available at aad.org in May 2022 contact Sara Peterson, speterson@aad.org.

Program Book (advance); Meeting E-News; Event 365 website; Doctor's Bag; Hotel branding and Individual Hotel Door Drops

Representative: Cathleen Gorby, Ascend Media

Phone: (913) 780-6923
Fax: (913) 780-4344
E-mail: cgorby@ascendmedia.com

Dermatology World

Advance mailing & bonus distribution onsite
Representative: Bridget Blaney, Ascend Media
Phone: (773) 259-2825
Fax: (708) 366-0303
E-mail: bblaney@ascendmedia.com

Journal of the AAD (JAAD)

Advance mailing & bonus distribution onsite
Representative: Aileen Rivera, Elsevier
Phone: (212) 633-3721
Fax: (212) 633-3820
E-mail: a.rivera@elsevier.com

City Wide/Out Of Home Advertising EMC Outdoor

Representative: Song Heo
Phone: 610-355-4450
E-mail: sch@emcoutdoor.com
Website: Emcoutdoor.com

Exhibit Advisory Committee

The Exhibit Advisory Committee was established to act in an advisory capacity to the Academy regarding issues and concerns affecting exhibitors. This committee meets in conjunction with the Academy Annual and Innovation Academy meetings. Exhibitors are encouraged to express their viewpoints and concerns to the Academy and/or Committee Members.

Current Members

Temple DalyAbbVie
Susan Navarro Allergan
Jennifer Lynch Beiersdorf, Inc.
Monica Whittaker.....Boehringer Ingelheim Pharmaceuticals, Inc
Mojo McDaniel..... Galderma Laboratories, L.P.
Tara Donahue L'Oreal
Ellie McShane Neutrogena
Deb SchubertProcter & Gamble
Bree Yoshikawa Obagi Medical Products



Save the date!

AAD Annual Meetings

BOSTON, MA • March 25–29, 2022
– NEW ANNUAL MEETING LOCATION!

NEW ORLEANS, LA • March 17–21, 2023
SAN DIEGO, CA • March 8–12, 2024

AAD Innovation Academy

VANCOUVER, BRITISH COLUMBIA • July 21–24, 2022
– NEW MEETING LOCATION!





American Academy of Dermatology | Association
9500 W Bryn Mawr Avenue, Suite 500
Rosemont, IL 60018-5216