

INFORMATION FOR FIRST AND SECOND RESPONDERS
EMERGENCY RESPONSE GUIDE



Rivian R1S

MPV

From 2022 - Present



Contents

1 Identification / recognition	Page 3
2 Immobilization / stabilization / lifting	Page 4
3 Disable direct hazards / safety regulations	Page 5
4 Access to the occupants	Page 9
5 Stored energy / liquids / gases / solids	Page 10
6 In case of fire	Page 11
7 In case of submersion	Page 11
8 Towing / transportation / storage	Page 12
9 Important additional information	Page 15
10 Explanation of pictograms used	Page 15

1 Identification / recognition



Identify a Rivian R1S electric vehicle by these features:

Front

- Rivian Compass logo hood ornament
- Stadium headlights

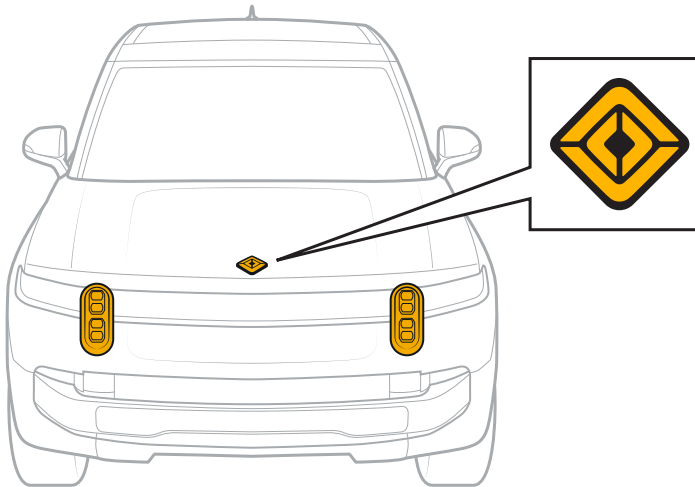

Rear

- Rivian name and model on the liftgate

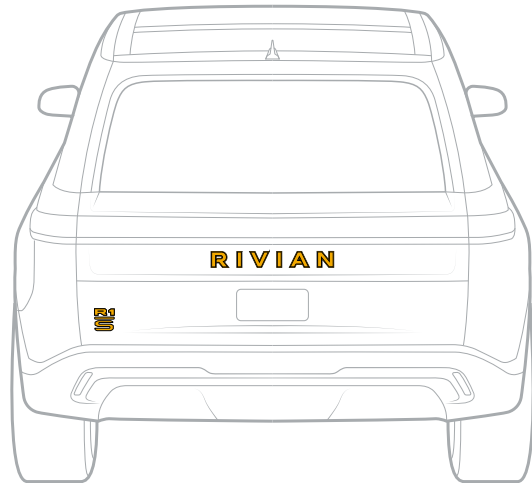

Side

- Rivian name on front door
- Rivian Compass logo on C pillar

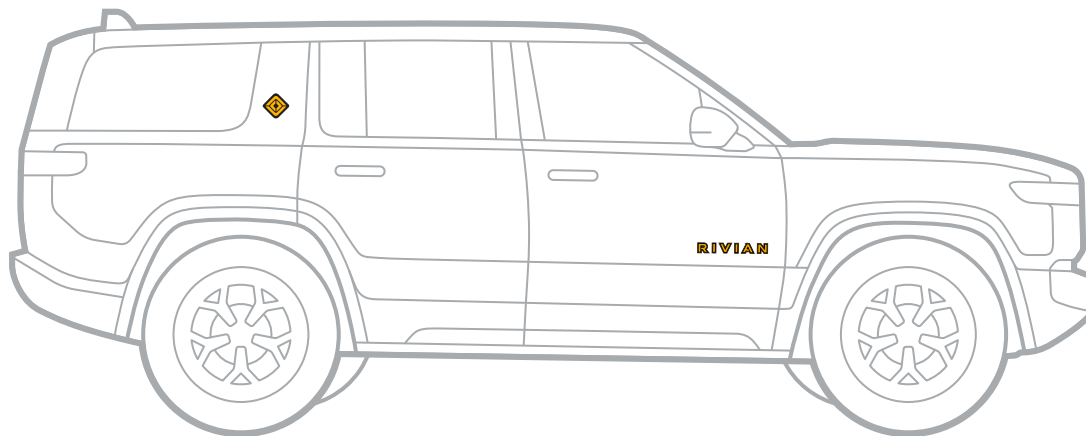

2 Immobilization / stabilization / lifting



Follow these steps to secure the vehicle and protect people from being hit or crushed.

NOTE

The vehicle has an adjustable air suspension. The vehicle may shift or sag when stationary. Use additional cribbing depending on the scenario.

1. Chock the wheels to prevent the vehicle from moving. Chock at least one wheel on each side of the vehicle.

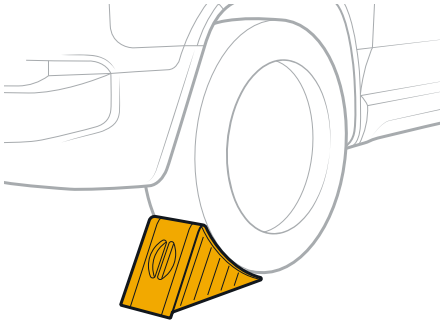

DANGER

Vehicles may move suddenly.

2. Open the driver door. The vehicle unlocks the doors when a crash is detected. If the exterior handles don't work, break the glass. For Model Year 2022-2024 vehicles, pull the loop-shaped release twice.

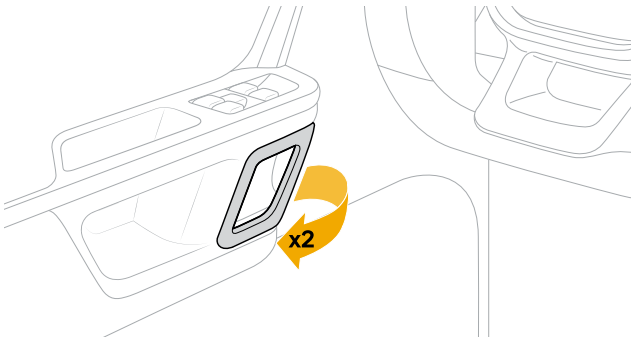

For Model Year 2025-2026 vehicles, pull the solid manual release lever once.



IMPORTANT

Don't press buttons on the key fob or Rivian phone app that would lock the doors or close the hood.

3. Shift into **P** (Park).

Press the button on the end of the lever on the right side behind the steering wheel.

NOTE

The display shows **P** when you put the vehicle in **P** (Park).

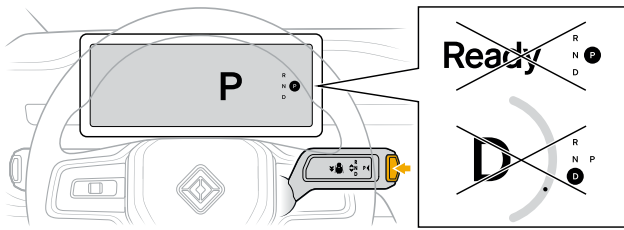

DANGER

If the display shows **Ready**, the vehicle is in high voltage on mode. Immediately press the brake and press **P** on the end of the drive stalk to shift into **P** (Park).

Safe Lift Points

Lift the vehicle at these points only.

IMPORTANT

Do not use jacks or lifting equipment such as airbags under the battery pack.

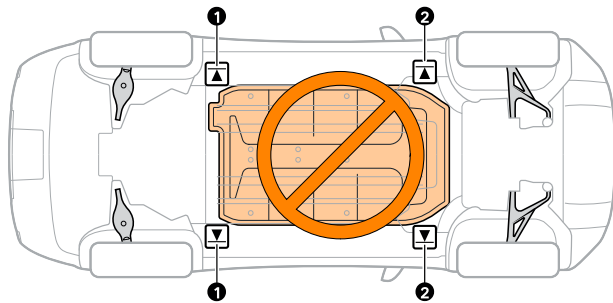

Item	Description
1	Rear jack location (frame rail)
2	Front jack location (frame rail)

3 Disable direct hazards / safety regulations



Rivian recommends you use the following tools when cutting the cut loop:

- Leather or abrasion-resistant gloves
- Personal protective equipment
- Insulated cable cutter

Follow these steps to access the cut loop. The key fob and phone app are the safest options.

1. Use one of these methods to open the hood:
 - Key fob
 - Phone app
 - Button above the front grille
 - Open Hood button on the centre display

NOTE

There is no manual override cable in the passenger compartment.

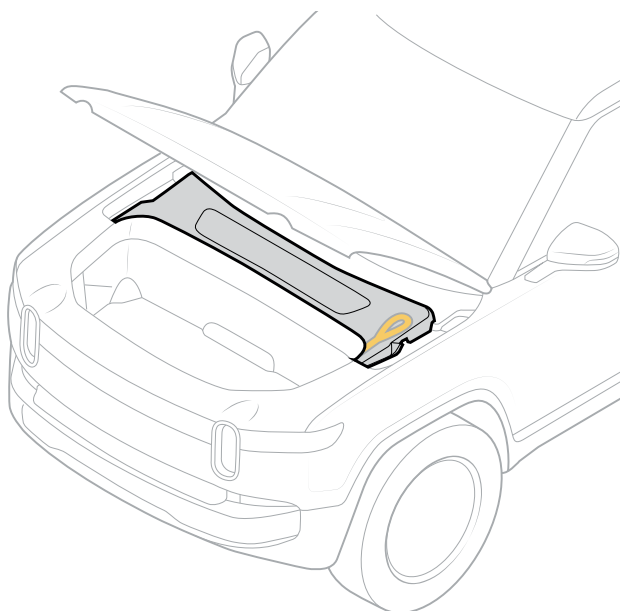
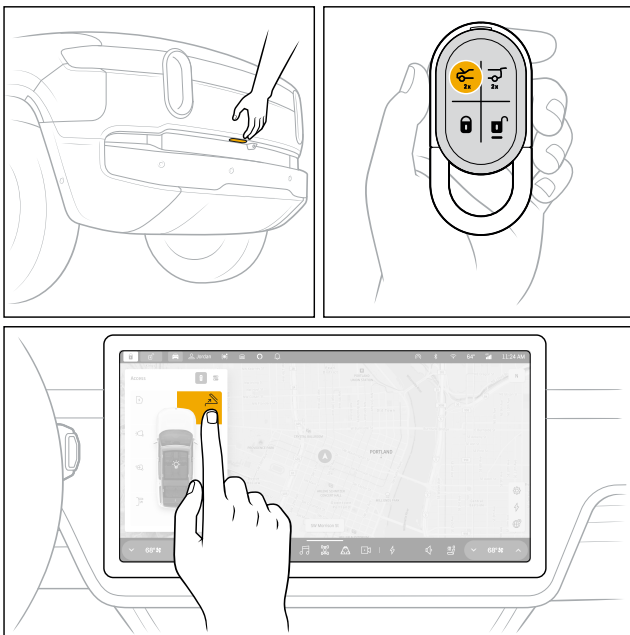

2. Find the yellow cut tag shown.

NOTE

The cut loop is under the air intake cover.

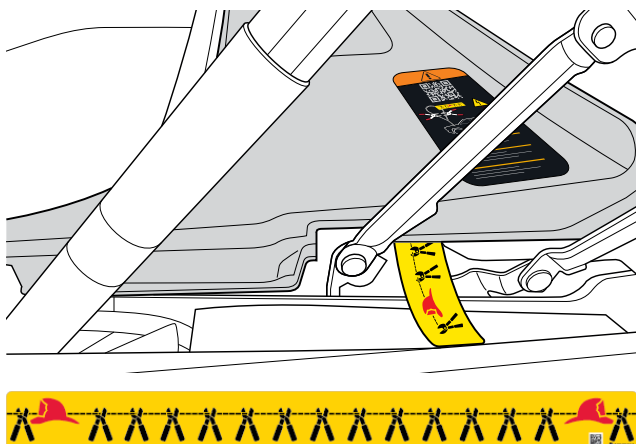

3. Grasp the air intake cover by the right side and pull it up.

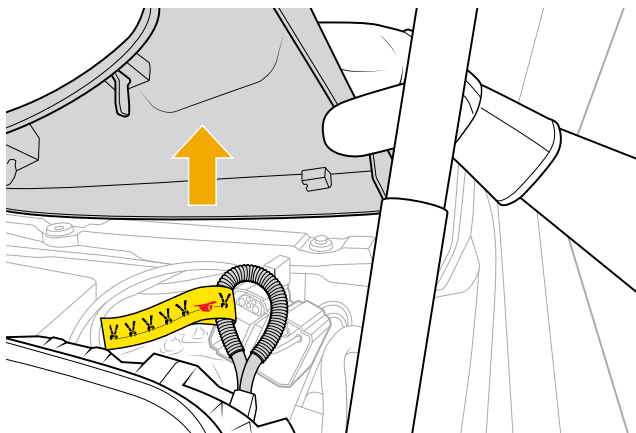

4. Find the loop of electrical cable with the yellow cut tag. Cut the loop at one end (1) and at the other end (2).

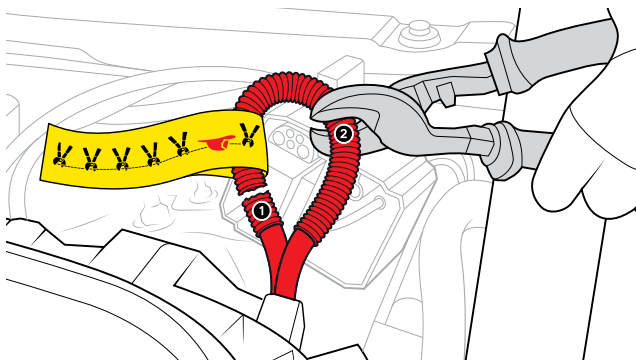

DANGER

When you cut in two places and remove a section of the cable, it helps prevent the ends of the cable from touching again. If the ends of the cable touch, it could restore high voltage, which could result in death.

5. Wait one minute.

NOTE

The air bags and seat belt system need up to one minute to discharge any remaining energy.

Open the Hood if 12-Volt Power Isn't Working

If you can't open the hood normally but you have time, use the manually open the hood procedure. If you don't have time, open the hood quickly using this procedure.

1. Insert the Halligan bar between the lower edge of the hood and the top of the light strip below the hood ornament and pry it open slightly.

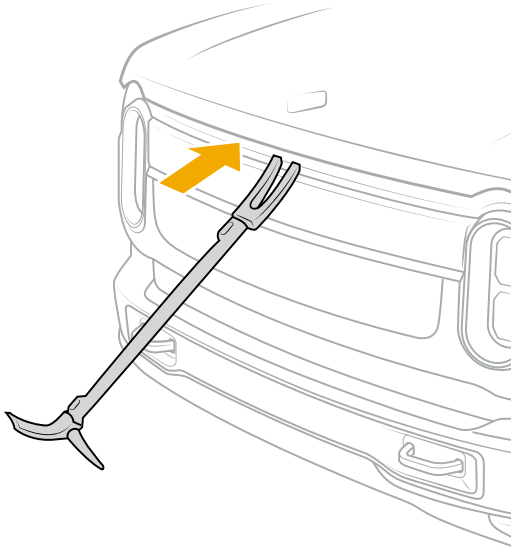

2. Insert the Hydraulic spreader and break the hood latch.
3. Lift the hood and follow the Cut Loop procedure.

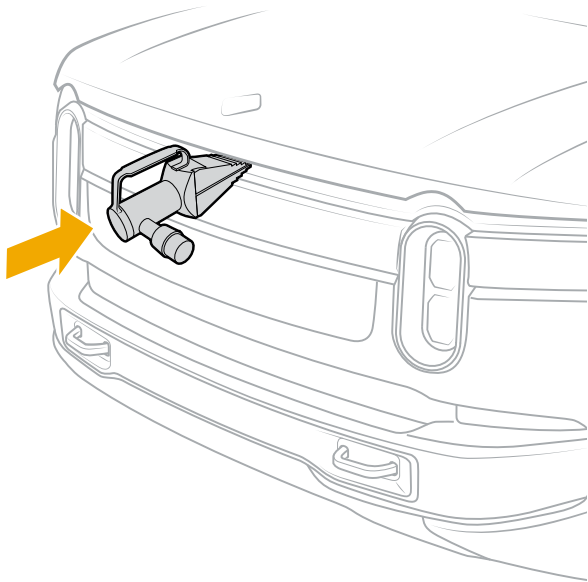

NOTE

If necessary, you may open the hood with a saw if you avoid the A/C compressor and 12 V batteries.

4 Access to the occupants



High Strength Steel

Cutting through this material may take longer than expected.

Wear personal protective equipment (PPE) when cutting high-strength steel.

Be careful not to damage the high-voltage battery.

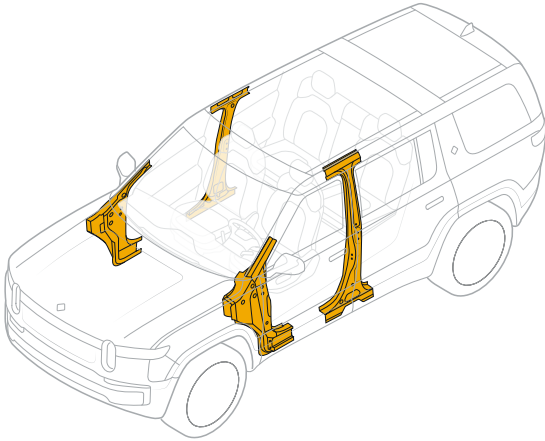

Do Not Cut Areas



DANGER

Never cut or damage the highlighted Do Not Cut areas.

NOTE

The actual location of components and cables may vary.

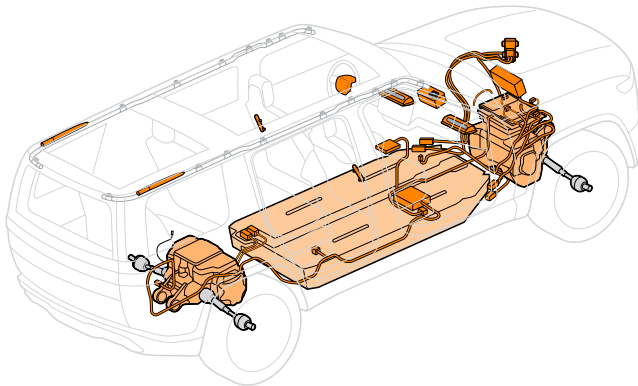

DANGER

- You could be injured, electrocuted, or die if you cut, pierce, or damage the highlighted areas.
- These areas contain lithium ion battery packs, high-voltage cables (up to 450 V), electrical outlet cables (120 V), traditional car batteries (12 V), compressed gas, and triggering devices.

Hydraulic Ram

If you need to use a hydraulic ram to rescue occupants, stay above the floor level, and do not use the floor inward of the door sill. This is to avoid contacting or damaging the high-voltage battery pack below.

5 Stored energy / liquids / gases / solids

12 V



Li-ion
450 V



Rivian vehicles use a lithium-ion high-voltage battery (up to 450 V) and high-voltage cable next to the axles.

In case of fire, do not cut the battery or cables in an attempt to cool them down.

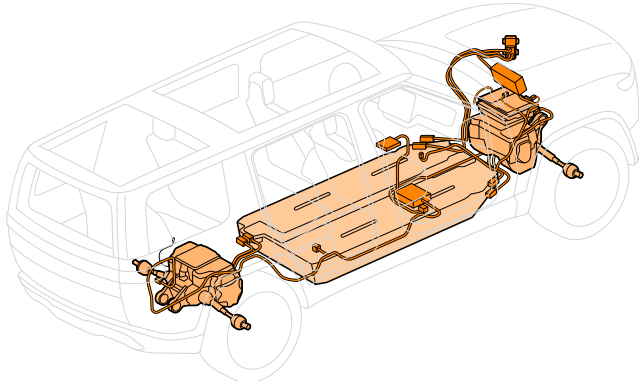

A damaged battery poses a potential electrical hazard that could release harmful and/or flammable gases.



DANGER

The flammable gases that leak from the battery could ignite.

After a fire, clean up by sweeping debris into a pile. Return all debris to the vehicle or containers.

To prevent runoff into nearby storm drains or other waterways, you may deploy fluid gathering materials such as booms or powders to limit runoff contamination.



WARNING

- Water applied to the battery pack can become caustic or could cause a chemical reaction and burn the skin. To prevent burns, apply more water for dilution. Rinse tools and clothing to decontaminate them.
- Avoid inhaling battery fire materials. Use personal protective equipment (PPE) to limit contact as much as possible.
- Do not remove the battery cover.

Electrical Hazard Guidance

Contact with exterior body panels or interior cabin surfaces doesn't require HV dielectric gloves. The vehicle chassis is isolated from the high-voltage system.

Standard PPE is sufficient for most extraction tasks. However, use HV dielectric gloves if your tactic involves:

- Direct contact with or working near orange high-voltage cabling
- Intrusive cutting or crushing of the battery pack (underfloor)
- Disassembling or penetrating high-voltage components (Inverters or DC/DC converters)

Always assume that orange components are energized (450 V).

6 In case of fire



IMPORTANT

Rivian believes that electric vehicle fires are best addressed with defensive firefighting and management of the environment to minimize risk. Only attempt to extinguish a fire if you have a specific need to do so.

Perform these steps to extinguish a vehicle battery fire:

1. Wear proper personal protective equipment with full SCBA when approaching any vehicle fire.
2. Use a fog pattern to approach the vehicle and extinguish the interior.

NOTE

If you observe sustained fire on the vehicle underside, centre line, near the axles, a traction battery fire is likely. Do not use a direct water application. Maintain fire control as the battery is consumed (approximately 30 minutes).

3. A minimum of 7,500-11,500 L (2,000-3,000 gal) will be needed. Consider an established water supply, a tender, or additional units to shuttle water to the pumping engine.
4. If water is not readily available, use defensive firefighting tactics to prevent the fire from spreading until a clear need to extinguish the fire is identified and water is available. If necessary, use CO₂, dry chemicals, or other fire-extinguishing agents to suppress the fire, for example, to extricate passengers, until water is available.
5. Use a thermal imaging camera (TIC) or infrared (IR) to monitor the battery temperature during the cooling process. Look for ambient temperatures at or below 100°C (212°F) to indicate the battery pack is cooling down. Temperatures above this limit indicate a potential for continued battery cell thermal events.
6. Continue evaluating the battery structure and apply water directly to any exposed areas. Submerge loose battery cells or modules in a 1-5% salt water solution for at least 24 hours.

IMPORTANT

- Only firefighters should extinguish a high-voltage battery fire.
- Use a hand-held extinguisher only to protect occupants as they exit the vehicle or for small fires that don't involve the high-voltage battery.
- Foam may suppress, but will not extinguish, a battery fire.
- A fire blanket may suppress, but will not extinguish, a battery fire. Combustible gases may be generated within explosive range.

7 In case of submersion

Rivian recommends that you wear personal protective equipment (PPE) when removing the vehicle from water.

Always remove a submerged vehicle from water before you attempt to deactivate, tow or transport it.

For safety don't try to recover a submerged vehicle from the water by yourself. Get help.

You may see small bubbles in the water near the vehicle (microbubbling). This isn't a sign that the water is electrified or will cause a shock.



DANGER

- If the battery is damaged, water may have entered the battery case. Use extreme caution and wear personal protective equipment (PPE) if you enter the water or attempt to tow the vehicle.
- Never attempt to charge a high-voltage battery that has been submerged, is letting off gas, or exhibits signs of external damage.
- When handling an emergency, always approach an electric vehicle from the side. Electric vehicles can run silently, and a damaged high-voltage battery can remain energized, allowing the vehicle to move unexpectedly.

8 Towing / transportation / storage



WARNING

- Only transport the vehicle on a flatbed tow truck.
- Fire Hazard. Towing Rivian vehicles with any wheels on the ground can lead to significant damage and overheating. Extreme overheating can cause a fire.
- Damage caused by improper towing is not covered under warranty.

Prepare the Vehicle

1. Ensure the front wheels face forward and are parallel with the vehicle.
2. Secure the steering wheel with a holder or strap to keep the wheels straight.



CAUTION

To prevent damage, don't use j-hooks to connect to any suspension components.

3. Connect the front of the vehicle to the tow truck winch with 1.8 m (6 ft) endless loops or a nylon bridle through the lower control arms.

NOTE

If you can't tow from the front of the vehicle, you can connect to the trailer hitch to from the rear. You can also tow from the tow eye, if equipped.

4. Press and hold the brake pedal.
5. On the centre display, choose **Settings**  > **Vehicle** > **Service**. Then turn on **Park brake release**.

NOTE

Park brake release turns off after 15 minutes. You can also turn it off by putting the vehicle in **P** (Park) or turning off **Park brake release** in the centre display.

6. Release the brake pedal and confirm release of the electronic park brake.
You can now load the vehicle onto the tow truck.

NOTE

If you can't release the electronic park brake, lift the rear wheels to load the vehicle onto the tow truck.

Connect to the Tow Eye

Connect using the tow eye if the vehicle is not equipped with tow hooks on the front bumper.

1. Remove the tow eye from the front trunk.

NOTE

Open the front trunk, and then lift the bottom panel to locate the tow eye storage area.

2. Locate the tow eye connection point on the passenger side of the front bumper.
3. Remove the cover from the tow eye connection point.
4. Screw the tow eye counterclockwise into the connection point until it is fully secure.
5. Connect the winch hook to the tow eye.
6. Press and hold the brake pedal.
7. On the centre display, choose **Settings**  > **Vehicle** > **Service**. Then turn on **Park brake release**.

NOTE

Park brake release turns off after 15 minutes. You can also turn it off by putting the vehicle in **P** (Park) or turning off **Park brake release** in the centre display.

8. Release the brake pedal and confirm release of the electronic park brake.

You can now load the vehicle onto the tow truck.

NOTE

If you can't release the electronic park brake, lift the rear wheels to load the vehicle onto the tow truck.

9. Pull as straight as possible. The angle can't exceed 30° in any direction to prevent damage to the vehicle.

Lift the Rear Wheels

If the battery is dead or you can't release the electronic park brake, lift the rear wheels to load the vehicle onto a tow truck.



DANGER

Secure the vehicle and connect it to the tow truck before you lift the rear wheels. The vehicle can roll when you lift the rear wheels.



CAUTION

Only lift the rear wheels to load the vehicle onto the tow truck. Don't tow the vehicle behind another vehicle or with two wheels on the ground.

1. Chock the front wheels to secure the vehicle.
2. Connect the vehicle to the tow truck using an endless loop through the front control arms or rear trailer hitch.
3. Lift the rear wheels using skates, a dolly, or a tow truck wheel lift.
4. With the rear wheels off the ground, position the vehicle to be loaded onto the tow truck bed.

You can now load the vehicle onto the tow truck.

NOTE

If using skates, use the skates to pull the vehicle all the way up the tow truck ramp.

Load the Vehicle onto the Tow Truck

After you've connected the vehicle, you can load the vehicle onto a flatbed tow truck as follows:

1. Ensure the **Park brake release** is turned on or the rear wheels are lifted.
2. Remove the wheel chocks, if needed.
3. Use the tow truck winch to pull the vehicle onto the tow truck bed.
4. Pull at 8 km/h (5 mph) or less to prevent damage to the powertrain.

NOTE

If you pull too fast, the vehicle stops and shifts to **P** (Park).

5. Tie down the vehicle using eight-point retention straps with two points of contact per corner.

**CAUTION**

To prevent damage, ensure the straps don't contact the brake lines or suspension components behind the tire.

6. Put the vehicle into **P** (Park).
7. Go to **Drive Modes**  in the centre display. Choose **All-Purpose** , and then choose **Low** under **Ride Height**.

Connect to the Trailer Hitch

Connect to the trailer hitch when you can't tow from the front of the vehicle.

1. Ensure the front wheels face forward and are parallel with the vehicle.
2. Secure the steering wheel with a holder or strap to keep the wheels straight.
3. Remove the trailer hitch cover.
 - a. Use a flathead screwdriver to loosen the two captive screws. Turn a quarter turn counterclockwise.
 - b. Grip the cover and pull straight down.
4. Insert a nylon bridle or short endless loops through the trailer hitch.
5. Insert the tow pin through the hitch to connect the bridle or loops, and then install the tow pin retaining clip.
6. Press and hold the brake pedal.
7. On the centre display, choose **Settings**  > **Vehicle** > **Service**. Then turn on **Park brake release**.

NOTE

Park brake release turns off after 15 minutes. You can also turn it off by putting the vehicle in **P** (Park) or turning off **Park brake release** in the centre display.

8. Release the brake pedal and confirm release of the electronic park brake.

You can now load the vehicle onto the tow truck.

NOTE

If you can't release the electronic park brake, lift the rear wheels to load the vehicle onto the tow truck.

Be careful when storing a damaged Rivian electric vehicle after an accident or fire. Be sure to secure it when you park it.

**CAUTION**

Don't use a forklift to move the vehicle. This could puncture the high-voltage battery or other components, and the vehicle weight could exceed the forklift's capacity.

Vehicle Storage

1. Use signage or some other visual indicator to identify it as an electric vehicle.
2. Store the vehicle outside at least 15 m (50 ft) away from other vehicles, structures, or combustible material.

NOTE

If this spacing can't be achieved, place the vehicle where it can quickly be towed or winched away. Consider access for fire personnel, fire apparatus, and a water supply, and leave space for fire personnel to periodically and quickly reassess with thermal imaging.

3. Notify others that the vehicle is on the property and ask them not to interact with it unless authorized.
4. Monitor a vehicle with a damaged high-voltage battery for signs of gas emissions, fire, or any potential issues from a leak. Leave the vehicle in the containment area for at least 24 hours.

**WARNING**

In some cases, lithium-ion batteries can self-ignite days after a major collision.

5. Rivian recommends creating a tape barrier around the vehicle in an isolated area of the lot.

















**DANGER**

Energy that remains in a battery is especially concerning if the high-voltage components or battery are damaged. Exposed wiring and parts can also create an electrical safety hazard.

9 Important additional information

N/A

10 Explanation of pictograms used

 Remove smart key	 HV battery Li-ion (450 V)	 High-voltage component	 High-voltage power cable
 Cable cut location		 High strength zone	 Lifting points
 Flammable	 Corrosives	 Hazardous to human health	 Danger to the environment
 Warning, high voltage	 Use plenty of water to extinguish the fire	 LV Battery (12 V)	 Electric vehicle
 Hood			