

CD
TECHNOLOGIES

**TECHNICAL
BULLETIN**

Internal Ohmic Testing

Typically the vented (flooded) lead acid battery is contained in a clear container and the condition of the cell is determined via float voltage checks, electrolyte specific gravity checks and a visual inspection of the internal components. The internal components such as plate grids and active material, straps joining the plates in parallel, separators, electrolyte, and sediment level and color are inspected to determine how they may have changed from their original condition such that the capacity of the cell would be affected.

For example, if the plates had grown significantly the pasted active material (PbO_2) to grid bond could be affected which would increase the cell's resistance and thus reduce its capacity. Or it may be observed that there is excessive black active material sediment in the base of the cell - this loss of active material would also result in an increase in cell resistance and loss of capacity, while grid corrosion and shedding are the normal wearout mode for the vented lead acid cell, these phenomena can be greatly accelerated due to overcharging, excessive cycling and high temperature operation.

While a visual inspection does not reveal all the possible problems which can occur that ailed the cell's ability to perform, and when the recommended performance capacity tests have not been periodically performed, observed internal component deterioration is the indication that a performance capacity test should be performed as soon as possible to determine the reliability of the battery.

The typical valve regulated lead acid (VRLA) multicell battery differs from the typical vented cell in that the container is sealed, preventing electrolyte additions and sampling and opaque precluding visual inspection of the internal components. This then limits the maintenance of the cell to checks of the float charging voltage and current, battery temperature and periodic performance capacity tests,

The typical VRLA battery is comprised of the components as shown in Figure 1. Figure 2 presents an equivalent circuit of the VRLA cell with the plate grids and active material, plate paralleling strap and electrolyte contributing approximately 80% of the total resistance of the battery. Any change in these components, such as grid corrosion, shedding of active material, strap or grip to strap corrosion, or drying of the limited supply of electrolyte will be reflected in an increase in the resistance of the battery. While techniques of discharging the battery at different rates to determine its resistance do exist, they are neither convenient or practical to perform in an operational environment.

Internal Ohmic Testing includes measurement of internal Resistance, Conductance, Impedance or Admittance and is widely used to determine the condition of the internal components of a battery. This testing serves as a trending and troubleshooting tool.

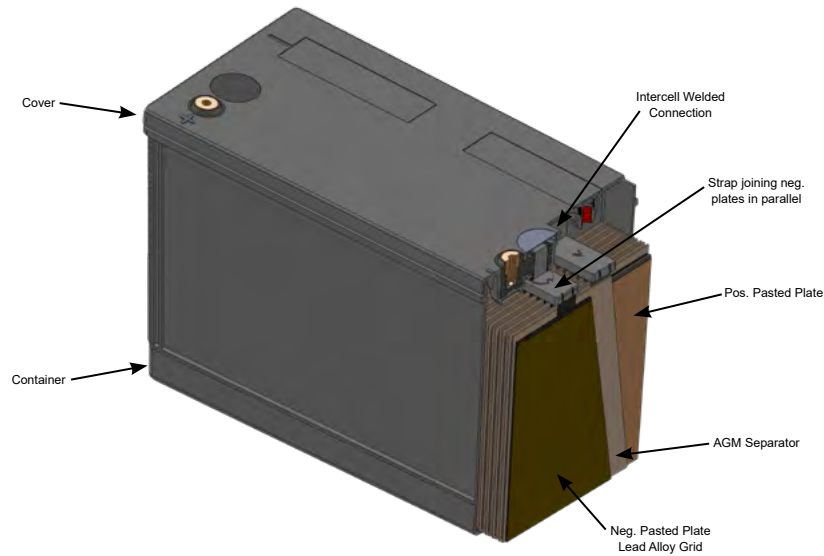

FIGURE 1

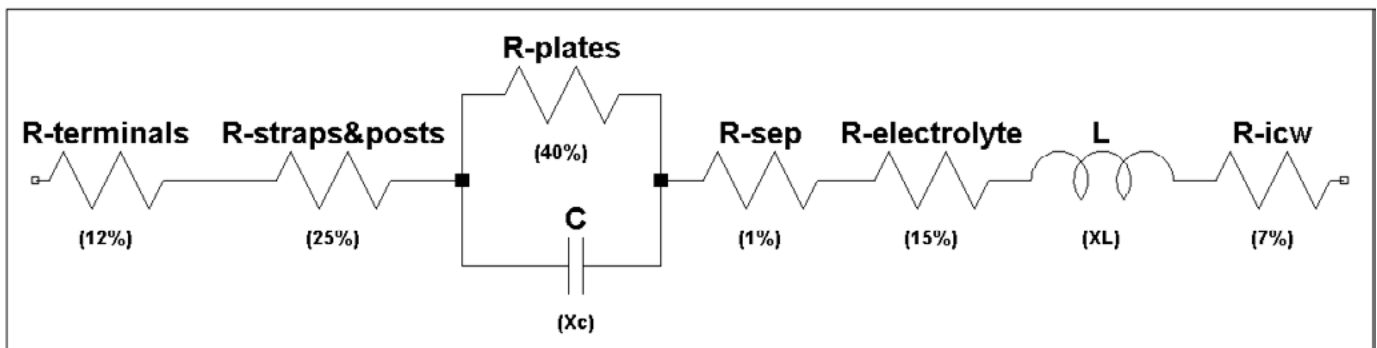

FIGURE 2 - Battery Equivalent Circuit

By utilizing AC testing techniques the impedance (or conductance) of the battery can be determined with no resulting discharge of the battery and little if any interruption in the service it provides. The impedance is actually the resistance of the cell to the flow of AC current as presented by the resistance (R) and inductive and capacitive reactance (X_L and X_C respectively) of the internal components. The impedance of the cell is frequency dependent, and somewhat different results will be obtained depending on the test equipment and test current frequency utilized. However the impedance can generally be expressed as:

$$Z = \sqrt{R^2 + (X_L + X_C)^2} \quad \text{Equation 1}$$

Where: Z = impedance in ohms
 R = DC resistance in ohms
 X_L = inductive reactance ($2 \pi fL$) in ohms
 X_C = capacitive reactance ($1/2 \pi fC$) in ohms

The absolute value of the AC impedance of the cell can be determined by simply forcing a specified AC current through the battery and measuring the AC voltage developed across the terminals. The impedance is then calculated as:

$$Z = \frac{E}{I} \quad \text{Equation 2}$$

The injection of test current through the cell under test can be accomplished with a circuit similar to that of Figure 3. The driving AC current is developed at the transformer secondary winding and adjusted to the specified level (eg. 10 amperes) and is then capacitively coupled to the battery under test by the capacitor C₁. The AC voltage then developed across each cell or battery in the string (E = I x Z) is measured and the impedance is calculated as per equation 2.

Since the test current amplitude and frequency is the same for each cell and battery in the string each time the test is performed, the calculated impedance for each cell and battery can be used to compare cells and batteries within the string and for changes over a period of time.

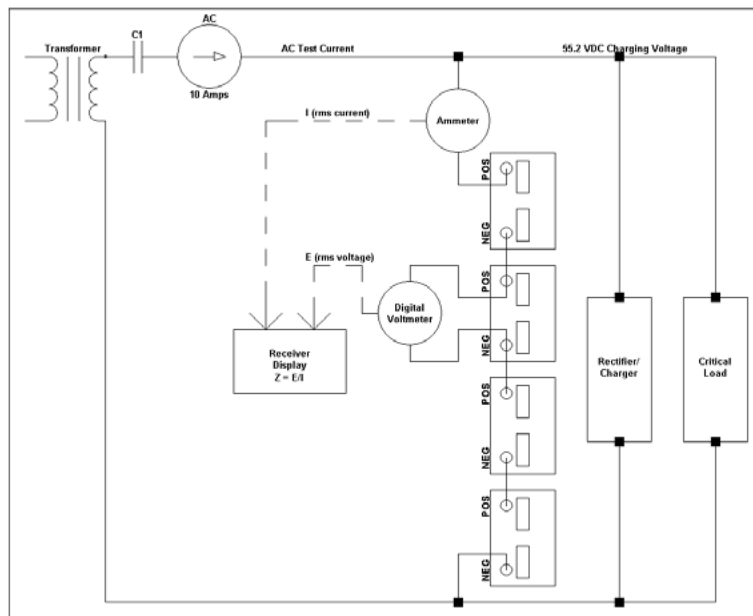

Figure 3 - VRLA Battery Impedance Test Setup

Typically the VRLA cells and batteries will all have an impedance of +/-20% of the average when new. This range will reduce as the cells/batteries continue in float service and the oxygen recombination cycle stabilizes and equalizes between the cells. As the cells age the average measured impedance will gradually increase indicating progressive deterioration of the cell internal components (plates and connecting straps) and/or drying of the electrolyte. Should a cell short, its impedance would initially decline dramatically. However, as the cell discharged due to the short, the electrolyte is consumed producing water and lead sulfate which then causes the impedance of the cell to rise to a very high value – approaching that of the short circuit itself. Naturally, an open would result in a dramatic increase in impedance.

Admittance is the reciprocal of impedance (1/Z) and conductance is the reciprocal of the real part or resistive portion of impedance (1/R). The conductance test is similar in effect to the impedance test however, in the conductance test a specified AC voltage is capacitively coupled to the test cell or battery and the resulting AC current flowing through the unit under test is measured. The conductance (C) is then calculated as 1/(E/I) or simply C = I/E. The unique characteristic of some popular current conductance testers is the ability to ignore the inductive and capacitive reactance of the cell or battery and directly measure only the resistive components affect.

Conductance measurement results in mhos may be used in the same manner as impedance values in ohms to troubleshoot a battery and trend the unit's condition over a period of time.

The manner in which the cell and battery impedance, conductance and capacity may vary with age is noted in figure 4. If a cell or battery impedance or conductance should vary more than 50% of the value from when it was new, the battery should be further evaluated to determine the cause. This evaluation should include a performance capacity test.

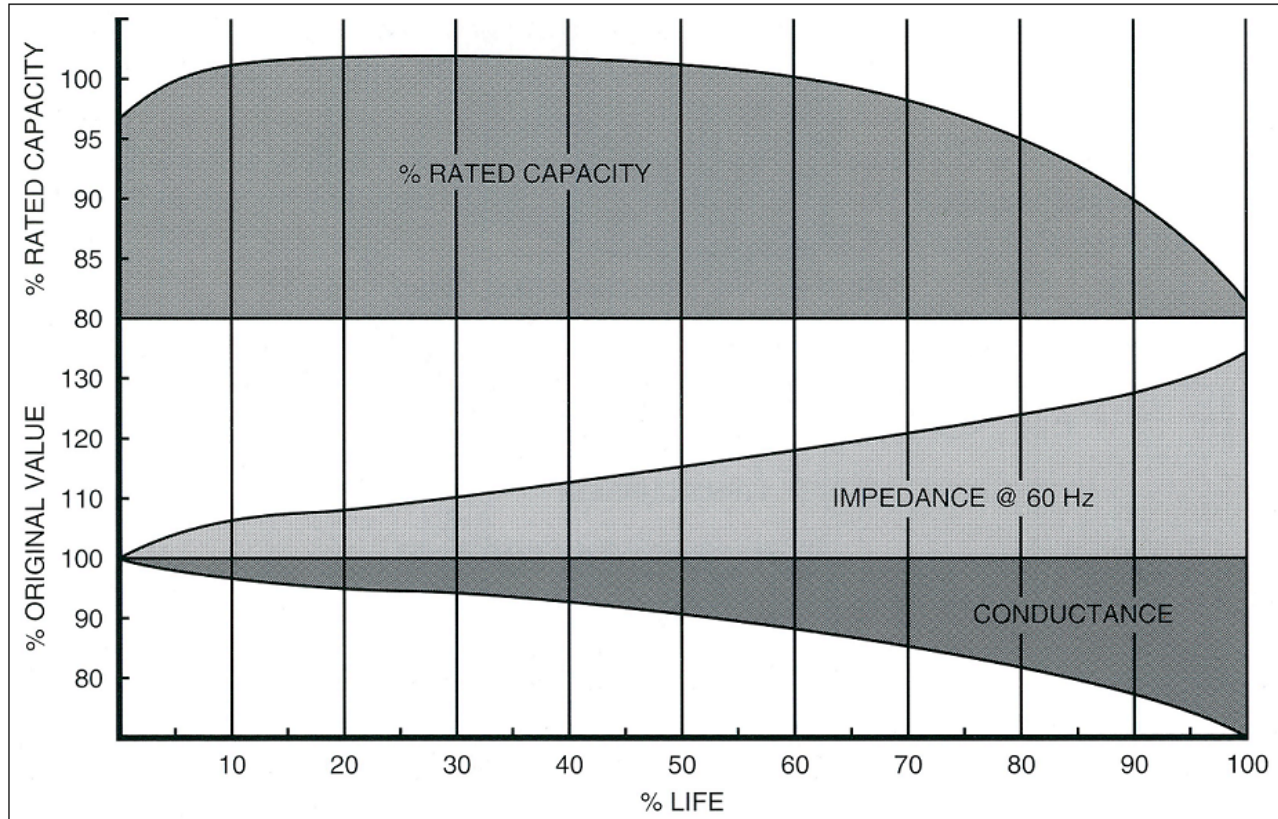

FIGURE 4 - VRLA Battery Impedance and Conductance vs. Capacity and Age

It is important to recognize that neither the impedance or conductance test is capable of replacing the actual performance capacity test since they are not able to provide a clear indication of all the potential problems which can cause a battery to fail. However, they can provide information alerting the technician to the need for further investigation of some potentially troublesome cells.

Table 1 provides typical values of impedance and conductance for C&D Technologies® VRLA battery products as measured with the AVO-Biddle BITE unit and the Midtronics Mdl. 5000 conductance tester respectively. The values are typical and the actual value measured on a new individual battery may vary +/-20% from the value shown. Also, the values measured will vary from that in the table with the type and model of test equipment utilized. The significance of values measured lies not so much in the specific value but how the value changes from it's original value over a period of time.

OHMIC REFERENCE

Refer to published Ohmic Reference Guide on our website: [Ohmic Reference Values Current VRLA Products](#)

BATTERY IMPEDANCE AND AC RIPPLE VOLTAGE

Usually, communications rectifiers are highly filtered and there is very little AC ripple voltage impressed on the connected battery. However, substation and UPS battery chargers typically impress a significant AC ripple voltage on the connected battery causing a measurable AC current to flow through the battery. If all cells had identical impedance, this AC ripple voltage would be evenly divided across the cells. However, since the same AC current flows through all the cells, those cells with higher impedance will exhibit a greater AC voltage across the terminals ($E = I \times Z$) while those with lower impedance will exhibit a lower AC voltage. While the AC current could be measured and the impedance calculated as:

$$Z=E/I$$

For troubleshooting purposes the measured AC voltages per battery can be compared directly and treated as though they were impedance measurements since the same current flows through all units. Figure 5 indicates how the readings might be interpreted.

VRLA BATTERY IMPEDANCE (RIPPLE VOLTAGE) MEASUREMENT

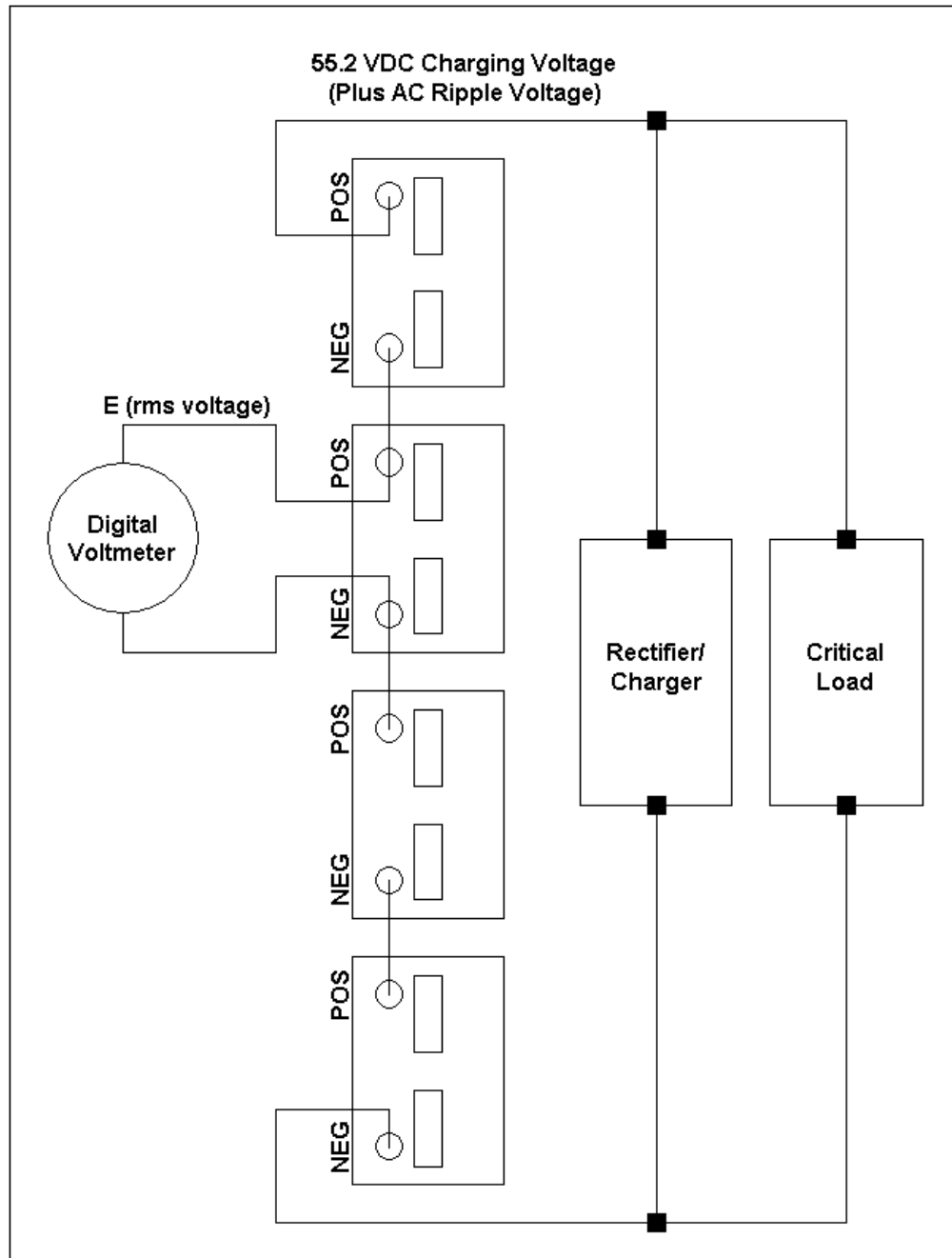

Figure 5 - VRLA Battery Impedance (Ripple Voltage) Measurement

The calculated values of impedance using this method will not be the same as that derived using commercial test equipment since the frequency of the AC ripple is different and it may also vary from time to time. Also, the value of the measured AC voltage per battery may vary at different times due to variation of the amplitude of the AC ripple voltage across the total string. However, with these constraints in mind, this technique can still provide a valuable troubleshooting tool.

BATTERY IMPEDANCE AND CONDUCTANCE VS. TEMPERATURE

It is important that when battery impedance or conductance measurements are taken that the temperature of the battery be measured and recorded. As noted in Figure 6, the values are only moderately affected above 77°F however, at cooler temperatures the impedance of the battery is greatly increased. When comparing values derived over a period of time the values must be normalized for temperature to obtain comparable results.

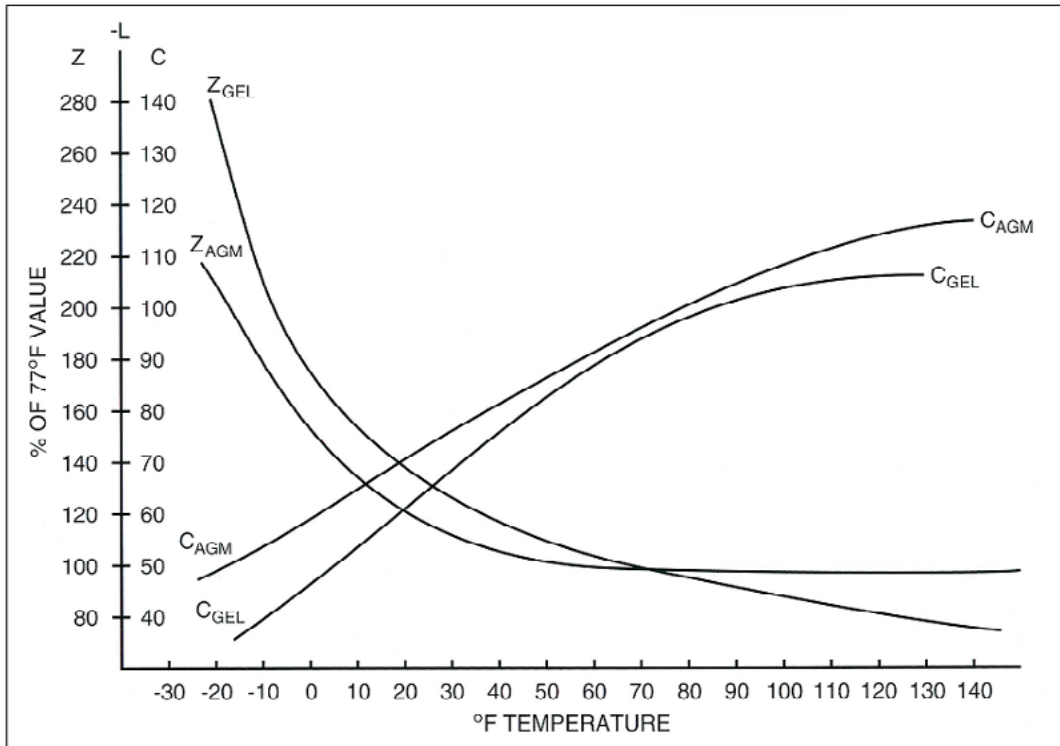

Figure 6-Impedance and Conductance VS. Temperature



©2023 C&D Technologies Inc. Any data, descriptions or specifications presented herein are subject to revision by C&D Technologies, Inc. without notice. While such information is believed to be accurate as indicated herein, C&D Technologies, Inc. makes no warranty and hereby disclaims all warranties, express or implied, with regard to the accuracy or completeness of such information. Further, because the product(s) featured herein may be used under conditions beyond its control, C&D Technologies, Inc. hereby disclaims all warranties, either express or implied, concerning the fitness or suitability of such product(s) for any particular use or in any specific application or arising from any course of dealing or usage of trade. The user is solely responsible for determining the suitability of the product(s) featured herein for user's intended purpose and in user's specific application.

cdtechno.com

World Headquarters
200 Precision Road
Horsham, PA 19044 USA
T: +1 (800) 543-8630
+1 (717) 553-7001