

STANDBY BATTERY RACKS ASSEMBLY INSTRUCTIONS

APPLIES TO ALL RDB SERIES PACKS

(READ ALL INSTRUCTIONS PRIOR TO INSTALLATION)

These instructions detail the proper procedure for installing C&D Standard and EP (Earthquake Protected) battery racks. The following describes how to locate, assemble, and load open-frame battery racks for C&D battery mounting applications. Proper attention to these instructions will help ensure safe, trouble-free performance.

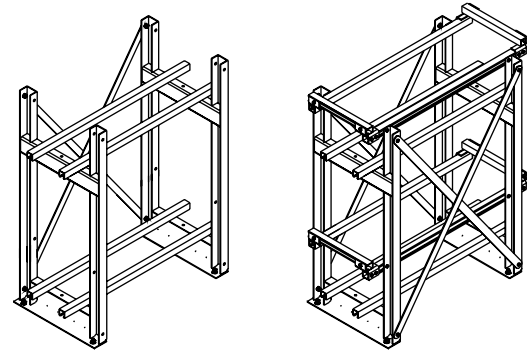

Two Tier Standard Rack

Two Tier EP Rack

Figure 1. Standard Vs. EP Rack

Standard and Earthquake-Protected (EP) Racks:

Earthquake-protected racks are similar to standard racks, with the exception of additional frame bracing, battery constraints and spacer elements. Frames are the same for both Standard and EP series. EP racks are certified to Section 1630 of the Uniform Building Code, 1994 edition. See Figure 1.

Configuration:

Racks are available in single or multiple tier/step arrangements as shown in Figure 2. Rack components are supplied loose and must be assembled and secured on-site in accordance with these C&D assembly instructions, the drawings included with the rack shipment, and applicable codes.

Rack Location:

Locate racks in a clean, cool, dry place so the batteries are not affected by sources of radiant heat, such as sunshine, heating units, radiators, steam pipes, etc. Variations of more than 5 degrees F between cells may cause the battery to become electrically unbalanced. Top rows of batteries in multiple-tier configurations tend to operate at slightly higher temperature than those on lower tiers. Always provide adequate ceiling clearance for ventilation and maintenance.

Anchoring:

To provide stability, safety, and seismic integrity (for EP series), racks must be securely anchored to the floor. Anchor bolts are to be installed per contractor specifications and in accordance with applicable codes. Do not attach rack to walls without consulting C&D first. Mounting holes are provided in the base of each frame. All frames must be secured to floor using all anchor bolt locations. It is the responsibility of the customer to secure racks in accordance with allowable floor loading, applicable codes and regulations.

Grounding:

Rack grounding provisions are integrated into the base of each frame. Two through holes are located at the center of the frame's bottom cross member and may be used to secure a standard NEMA lug. These holes are 0.44" in diameter and 1.0" between centers. The surfaces surrounding the holes have been masked and are free of powder coat to allow electrical contact. Frame to frame grounding integrity is accomplished via the lower support rail, attached to each frame with Internal/External "star" washers.

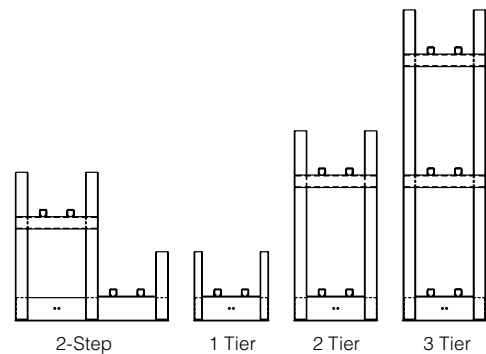

Figure 2. Typical Rack Configurations

CAUTION:

- Do not install batteries until the rack has been properly installed, with all bolts tightened to specified torque and frames anchored to the floor.
- Do not use oil or grease as a lubricant for cell installation. Lubrication is usually not required due to the low friction interface of the insulating covers. If necessary, a small amount of water or unscented talcum can be applied to the rail covers to reduce friction.

ASSEMBLY INSTRUCTIONS FOR STANDARD AND EP RACKS

- 1 Material Verification:** Battery racks are shipped unassembled with a complete set of related drawings and documentation. Check received parts and quantities against the rack's bill of materials on provided drawings and/or packing list. Do not assemble rack if parts are missing or quantities are incomplete.
- 2 Required Tools:** Torque wrench (0 to 65 ft.-lb.) with 9/16" and 3/4" Hex socket. Adjustable wrench or 9/16" and 3/4" box wrenches, tape measure, square and leveling device.
Note: Consult manufacturer's instructions for tools required to install floor mounting hardware.

- 3 Location of Rack Assembly:** When determining rack location and floor bolt pattern, use applicable drawings provided with rack shipment. Locate the rack's general position, considering boundary and aisle clearances. Locate floor mounting locations using provided drawings. See Figure 3.
Note: Floor mounting hardware is to be determined in accordance with applicable building codes, not by C&D.
- 4 Initial Assembly:** Place frames over installed floor mounting hardware, finger tight. (Hardware not supplied by C&D). All frames must face the same direction. Install back cross braces, finger tight. See Figure 4. Do not install front cross braces at this time (if required).
Note: Cross bracing pattern along the length of the rack may not necessarily be symmetric. Cross bracing pattern and location (front, middle, or back) is detailed on assembly drawing provided with the racks.

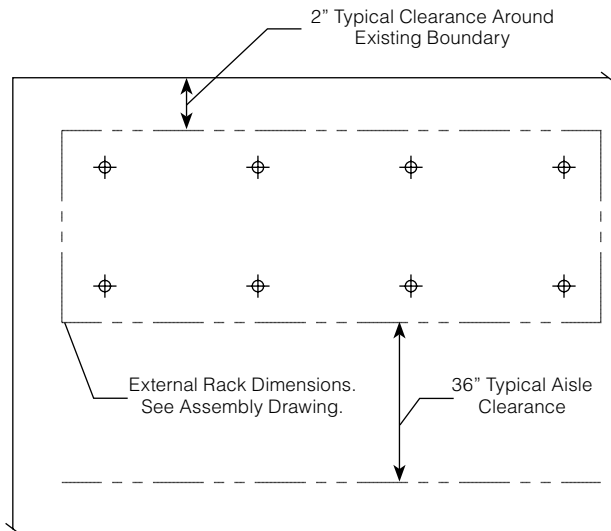

Figure 3. Rack Assembly Location and Anchor Bolt Pattern

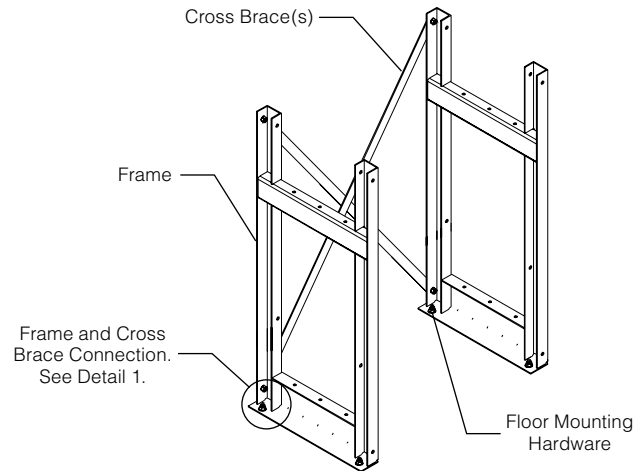
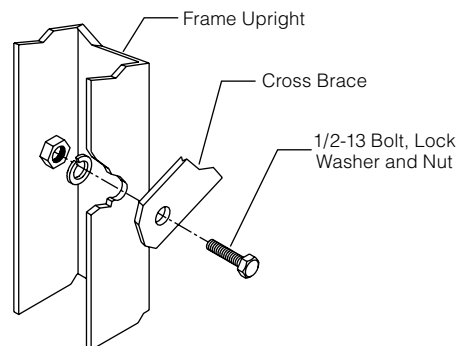

Figure 4. Initial Assembly



Detail 1. Brace to Frame connection (Reverse View)

ASSEMBLY INSTRUCTIONS FOR STANDARD AND EP RACKS (CONTINUED)

5 Installing Support Rail(s): Place support rail(s) in location using supplied 3/8" bolt, washer, serrated strut nut, finger tight. Align support rails with "A" dimension from rack assembly drawing. Install rail covers. See figure 5.

Note: An internal/external "star" washer is used in place of lock washer on bottom tier or step, for grounding connection. Optional third rail should be installed at this time (L-Series only).

6 Leveling: Check that the rack is level and square. Torque down all bolts. First torque the cross brace bolts to 55-65 ft.-lb., then torque the rail to frame bolts to 15-20 ft.-lbs. Torque anchor bolts to manufacturer's recommended value.

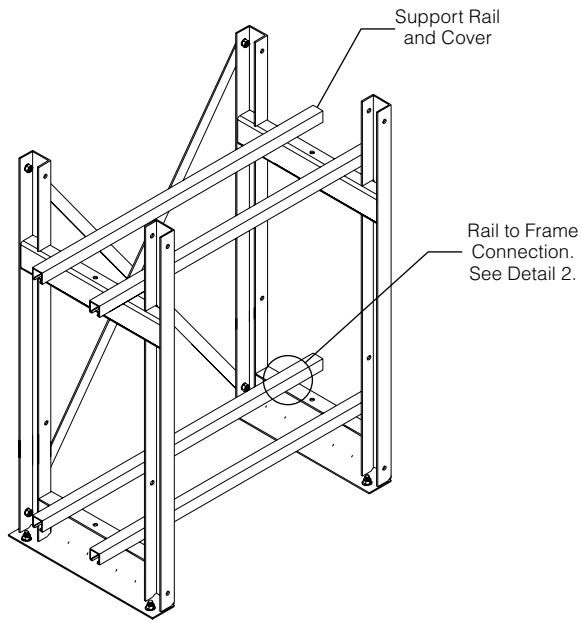
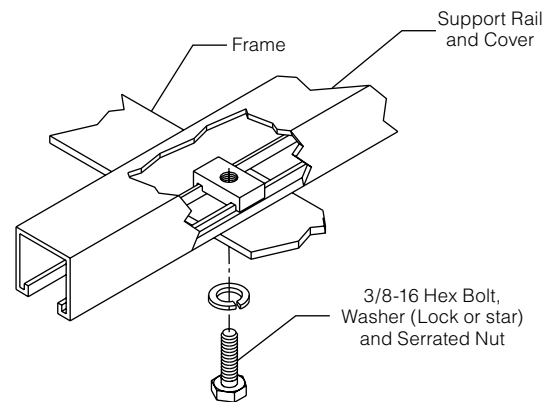

Figure 5. Support Rail Installation



Detail 2. Frame and Support Rail Connection

At this point, you have installed a **C&D Standard Rack**, please proceed to step 8 for cell installation or if you have an **EP Rack**, continue on in this procedure.

ADDITIONAL ASSEMBLY INSTRUCTIONS FOR EARTHQUAKE PROTECTED (EP) RACKS

- 7 EP Rack Assembly (Continued):** Install all back restraint rail(s) and cover(s). See Figure 6. If installing a rack to hold either a JC or XTJ battery system, the provided spacer block must be installed between the restraint rails and the frame. See Detail 3. Position front restraint rail and cover temporarily next to front support rail prior to installing cells. DJ Series battery racks to utilize lower set of restraint rail holes to avoid interference with the handles.
- 8 Cell Installation Procedure:** If not instructed otherwise, install cells starting at the center of the bottom row and, working out to each end, leave a half inch space between cells. For EP racks, use spacers between cells as supplied.

Do not use oil or grease as lubricants. Instead a small amount of water or unscented talcum may be applied to the rail cover to help reduce friction. For rows having an odd number of batteries, the center of the first battery installed will match the center of the row. For rows having an even number of batteries, a cell space will coincide with the center of the row. *Pay attention to polarities and terminal placement.* Refer to the battery's Installation and Operating Instruction manual for more details. All cells should be pushed back against back restraint rail and cover. Up to 1/8" gap between restraint rail and cells is acceptable. Repeat this procedure for remaining steps and tiers, working upward. See Figure 7.

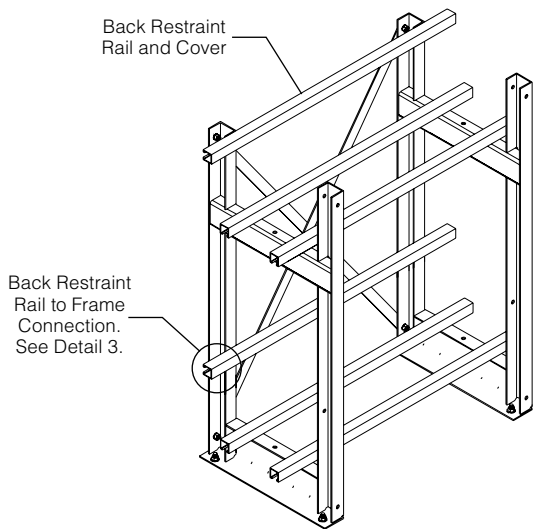

Figure 6. Initial Step For EP Rack

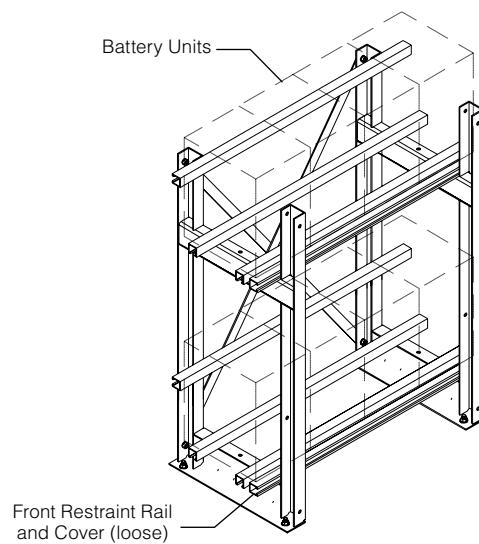
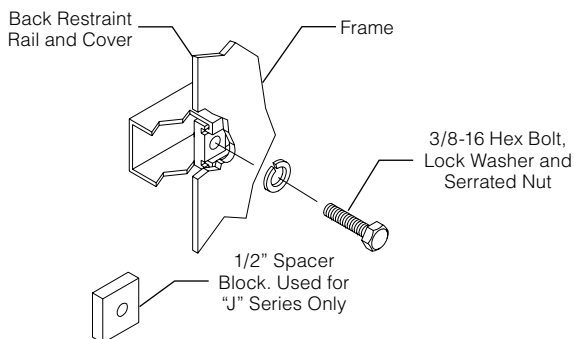

Figure 7. Cell Installation



Detail 3. Frame and Restraint Rail(s) (Reverse View)

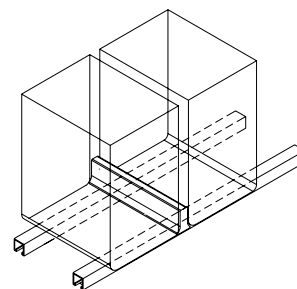

Figure 7a. Cell Spacer Detail (L-Series)

ASSEMBLY INSTRUCTIONS FOR STANDARD AND EP RACKS

- 9 Front Restraint Rail (EP only):** With the batteries in place, slide the front side support rail and cover up from its resting location to its mounting location, aligning with rear side restraint rail. Install hardware and torque to 15-20 ft.-lbs. See Figure 8.
- 10 Final Assembly:** Install corner brackets, end restraint rails, and covers. Position end restraint rail against end battery unit. See Detail 4. Note that the corner bracket may be reversed by 180° if required. Install all front cross braces if indicated by rack assembly drawing. Torque to 55-65 ft.-lbs. See Figure 9 for final rack assembly.
- 11 Battery Arrangement:** Install inter-cell and inter-unit connectors and cable assemblies as specified by battery arrangement. Refer to Battery Installation Manual (RS-1476) for more detail on battery connection and initialization change.

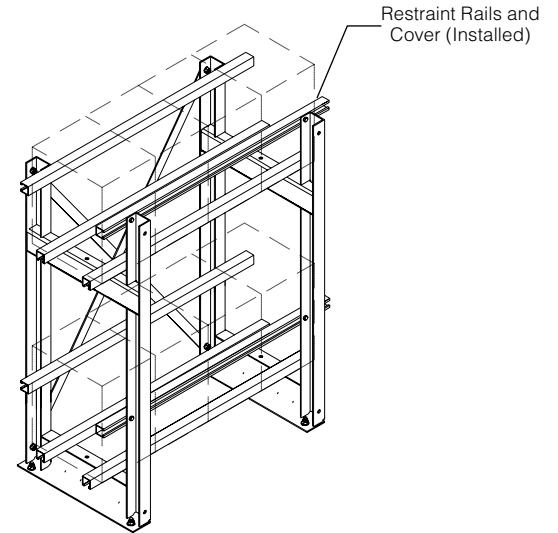

Figure 8. Installed Front Restraint Rail

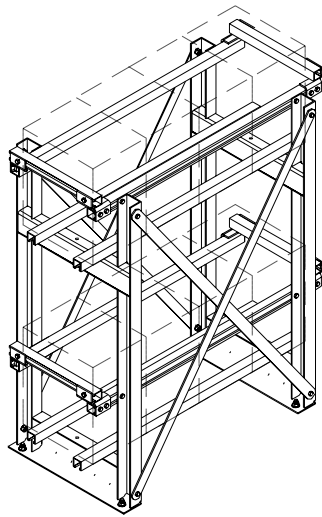
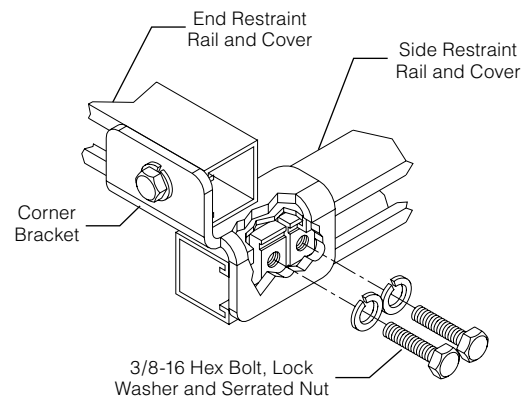

Figure 9. Assembled EP Rack, With Front Cross Braces



Detail 4. End Restraint Rail(s) and Corner Brackets

ADDITIONAL INSTRUCTIONS FOR MULTI-RACK ARRANGEMENTS

Back to Back Assembly:

Where two rows of racks are required, two rack assemblies may be installed in parallel front to back.

Frame Location:

Locate back to back frames relative to each other as shown, such that the rear cross brace attachment holes align for the two adjoining frames. All braces must be installed, as described previously, except that a single bolt may be used to connect the front and rear frames and respective cross braces. Use 3/16" spacers and/or washers to fill gaps between adjacent frames. See figure 10.

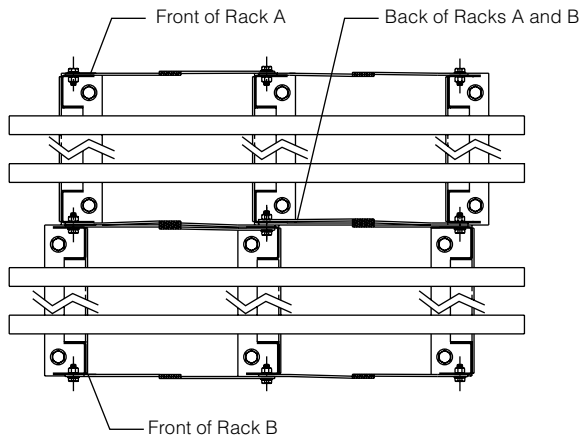

Figure 10. Back to Back Assembly

End to End Rack Installation Instructions:

Where a continuous rack string is required, two racks may be installed adjacent in length.

Frame Location:

End to end rack assemblies are installed as two individual, stand-alone rack assemblies as shown. When installing standard racks, the minimum clearance between racks is 0". When installing EP racks the two racks must be spaced apart so that the minimum distance between the ends of the support rails is 5". See Figure 11.

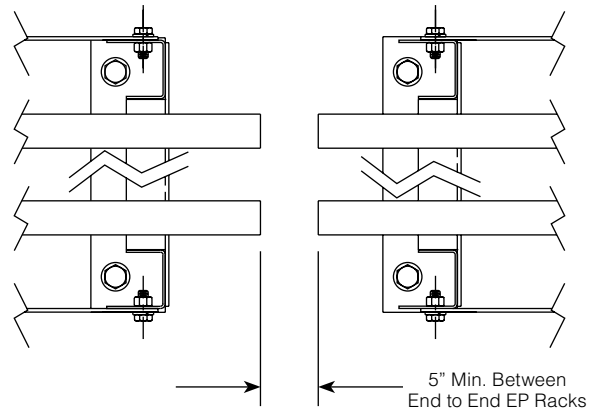

Figure 11. End to End Installation