



ESR Supplement Class A Vault Guide

April 2026



Copyright © 2026 Portland General Electric. All rights reserved. No part of this publication may be reproduced without prior written permission of Portland General Electric.

Information in this document is accurate at the time of publication but is subject to change without notice. Gray highlighting indicates change from last publication.

Portland General Electric Company
Utility Standards Engineering
3700 SE 17th Avenue
Portland, Oregon 97202

Table of Contents

| | |
|---|----|
| PGE Contact Information | 1 |
| PGE Teams Assisting in the Design Phase..... | 1 |
| PGE Teams Assisting with the Construction and Inspection Phases of a Class A Vault..... | 2 |
| Phone Numbers | 3 |
| 1 Preliminary Information | 5 |
| 1.1 Purpose | 5 |
| 1.2 Definition of Class A Vault..... | 5 |
| 1.3 Scope | 5 |
| 1.4 Key Elements to Initiate a Design..... | 6 |
| 1.5 Required Design Documents | 6 |
| 1.6 Customer-Provided Equipment and Materials | 7 |
| 1.7 Safety | 7 |
| 1.8 Accuracy of Information and Conflicting Requirements | 7 |
| 1.9 Summary of Architectural / Engineering Design Requirements | 8 |
| 2 General Design Process Considerations..... | 10 |
| 2.1 Access | 10 |
| 2.2 Vault Room Size (Minimums)..... | 10 |
| 2.3 Electrical Room Location..... | 11 |
| 2.4 Minimum Safety Clearances | 11 |
| 2.5 Grades | 19 |
| 3 Standard Construction Sequence Elements..... | 20 |
| 3.1 Ground to Structure: UFER | 20 |
| 3.2 Working Ground (Equipotential Ground) | 25 |
| 3.3 Floor Construction..... | 27 |
| 3.4 Wall Construction..... | 27 |
| 3.5 Primary Conduit Entrance | 28 |
| 3.6 Rigging Anchors..... | 28 |
| 3.7 Lighting, Switches, and Outlets (Boxes and Connecting Conduits) | 29 |
| 3.8 Fire Suppression..... | 30 |
| 3.9 Climate Control and Ventilation..... | 31 |
| 3.10 Ceiling Design and Construction | 31 |
| 3.11 Vault Detailing..... | 32 |
| 3.12 No Backup Generator Present | 35 |
| 3.13 Additional Items | 36 |
| 4 Construction Process | 37 |
| 4.1 Required Labels before Final Inspection | 37 |
| Appendix A. Approved Connection Bus | 38 |
| Appendix B. Personnel Hatch Specification (3-Foot × 3-Foot Doors)..... | 41 |
| Appendix C. Equipment Access Hatch (6-Foot × 8-Foot Doors)..... | 42 |
| Appendix D. Ground Insert Specification..... | 43 |

| | | |
|-------------|---|----|
| Appendix E. | Spread Anchor Specification..... | 44 |
| Appendix F. | “Bug-Eye” Emergency Egress Lights Specifications | 45 |
| Appendix G. | PGE-Supplied Fan Specifications | 46 |
| Appendix H. | PGE-Supplied Fan Bracket Mounting Hardware | 47 |
| Appendix I. | Simpson Strong-Tie “Blue Banger” Wood-Form Insert..... | 48 |
| Appendix J. | Husky and Atkore Product Sheets and Distributor Contact | 50 |
| Appendix K. | Heat Detectors Product Information..... | 51 |
| Appendix L. | Fall-Restraint Anchors | 53 |
| Appendix M. | Class A Vault Inspection Guide and Sequence..... | 54 |

PGE Contact Information

PGE Teams Assisting in the Design Phase

The following teams need to receive application materials at the start of a project.

| Team | Key Words | Role |
|--|-----------------|---|
| <p>Design Project Manager (DPM) Provided after submission of a service request in PowerPartner.</p> | Project Manager | <ul style="list-style-type: none"> ▪ Coordinates PGE’s review of a service request. ▪ Sends final gear approval. ▪ Designs the service, including selecting the type of transformation, size of the transformer, and conduit pathway. ▪ Reviews and approves/rejects proposed locations for transformers. ▪ Provides the customer with an approved job sketch (a.k.a. Design). |
| <p>Lighting Design Project Manager To contact a Streetlights DPM, contact the Service Coordination team at 503-323-6700.</p> | Lighting DPM | <ul style="list-style-type: none"> ▪ Designs new/upgraded streetlights in parallel with the customer’s service design, if required by the municipality. ▪ Designs area lighting services. |
| <p>Interconnection Coordinators (Solar, Wind, Battery, etc.) To contact the Interconnection team, call 503-464-8100.</p> | Renewable Lead | <ul style="list-style-type: none"> ▪ Receives interconnection applications. ▪ Coordinates the technical review of solar, wind, and other qualifying renewables. ▪ For approved interconnections, requests final PGE inspection and meter installation. ▪ Coordinates review of batteries and requests for parallel generation. |
| <p>Fleet Partner Product Specialist To contact the Fleet Partner team, email fleetpartner@portlandgeneral.com.</p> | EV Charging | <ul style="list-style-type: none"> ▪ Receives fleet electrification applications. ▪ Coordinates the technical review of fleet electrification. |
| <p>Meter Gear Engineers</p> | Gear Review | <ul style="list-style-type: none"> ▪ Reviews all gears 400 A and greater. ▪ Discusses gear requirements with electricians. |

PGE Teams Assisting with the Construction and Inspection Phases of a Class A Vault

The following teams may assist the DPM in reviewing project application materials and site.

| Team | Project Phase(s) | Role |
|---|---|--|
| Field Construction Coordinator (FCC) | Pre-Design, Design, Pre-Construction, and Inspection Phases | <ul style="list-style-type: none"> ▪ Facilitates the pre-construction meeting with the customer’s civil contractor(s) installing the vault and conduit infrastructure for underground services. ▪ Conducts necessary trench and conduit inspections for services 400 A and greater. ▪ Supports streetlight improvement plans. |
| Construction Project Manager (CPM) | Permits and Construction and Inspection Phases | <ul style="list-style-type: none"> ▪ Facilitates project coordination after PGE’s approved job sketch has been issued. |
| Service Inspector To schedule an inspection, contact the Service Coordination team 503-323-6700. | Inspection Phase – Final Inspector | <ul style="list-style-type: none"> ▪ Conducts final inspections for all services: residential, commercial, mixed-use, and medium voltage. ▪ Installs riser brackets on PGE poles. Drops off the bottom portion of PGE lockboxes. |
| Metermen | Inspection and Construction Phase | <ul style="list-style-type: none"> ▪ Installs Current Transformer and meters greater than 320 A. ▪ When customers rewire or upgrade existing services, reviews the service to ensure it meets current PGE requirements. ▪ Installs meters for solar, wind, and other renewables. |
| Crews | Construction Phase | <ul style="list-style-type: none"> ▪ Builds and energizes the service! |

Phone Numbers

| Contact | Phone Number | | |
|---|--------------------------|--------------|--------------|
| | Toll-Free | Local | Fax |
| Service Coordination To open a new request for service or schedule a final inspection | 800-822-1077 | 503-323-6700 | 503-612-3501 |
| Customer Service To request billing and payment information for existing accounts | 800-542-8818 | 503-228-6322 | 503-612-0151 |
| Tree Trimming | 800-544-1794 | 503-736-5460 | — |
| Oregon Utility Notification Center To locate underground utility cables | 8-1-1 or 800-332-2344 | 503-246-6699 | — |
| Outages and Emergencies, 24 hours To report a power outage | 800-544-1795 | 503-464-7777 | — |
| Light Out (Streetlights) To report a streetlight problem | 800-544-1795 | 503-464-7777 | — |
| Energy Theft Hotline To report an energy theft | 800-962-8184 | — | — |
| Interconnection Team To obtain information on customer-owned solar and wind systems, and batteries | 503-464-8100 | — | — |

Email Addresses

| Contact | Email Address |
|--------------------------|--|
| Service Coordination | service.coordinators@pgn.com |
| Tree Trimming | trees@pgn.com |
| Light Out (Streetlights) | LightOut@pgn.com |

1 Preliminary Information

1.1 Purpose

Class A vault development is a cooperative and collaborative process involving a project's development team (architectural, structural, civil, electrical, mechanical) and PGE's teams (PGE's Design Project Manager, Field Construction Coordinator, Distribution Engineer, and Line Operations Team). Creating a partnership at the beginning of a project aids successful and timely delivery of electric service.

The Guide assists the customer's project development team, in collaboration with internal PGE stakeholders, in designing and building a *non-network* vault in the PGE service area. This Guide summarizes the elements in a Class A vault, illustrated where practical, and presented as much as possible in a construction sequence. Figures and text in this Guide should not serve as construction plans.

Additional requirements and distinct materials will be required for in-building transformer vaults in PGE's network transformer zone. See the [Electric Service Requirements book](#) for a map of PGE's network transformer zone.

This edition replaces all earlier editions. All new and updated content in this book is highlighted in gray, just like this paragraph. If changes have been made to a figure, the figure's caption is highlighted.

Major changes in this edition include:

- Oil sump capacity clarified.
- Appendix A images of the approved connection bus updated.

1.2 Definition of Class A Vault

A Class A vault is a dedicated space for PGE to house electrical equipment (primary conductors, transformers, etc.) within a customer's building. PGE requires a Class A vault in the following conditions:

- A private property location for a pad or pre-cast, vault-mounted, at-grade transformer is not available.
- An outdoor location lacks sufficient space to meet required PGE clearances or access requirements.
- An outdoor location is prohibited or limited by jurisdictional codes.

1.3 Scope

PGE's required location for Class A vaults is at ground level (a.k.a. "at-grade"), adjacent to an exterior wall, and accessible via paved streets or private driveways capable of supporting 70,000-pound vehicles. In locations where a ground-level vault is not feasible, due to municipal code or requirements, a P-1 (one level below street grade, a.k.a. "sub-grade") location may be considered.

This Guide provides references to minimum vault sizes, heights, floor, wall, and ceiling construction requirements; bonding and grounding requirements; equipment and personnel access requirements; seismic and safety requirements; construction sequence and inspection

requirements; and final service inspection requirements for installation of transformers, conductors, and energization of the project.

All listed requirements are contained in PGE Standard LD31007. The Class A Guide should be referenced with the current version of LD31007. Consult the PGE Field Construction Coordinator assigned to the project for further clarification.

1.4 Key Elements to Initiate a Design

The design of a Class A vault begins with these key elements:

1. **Building Service Voltages and Loads:** The customer must provide an accurate load for the building for PGE to determine the size and number of transformers required. Service voltages and service sizes determine the number and size of required transformers, which in turn determine the size requirement for the Class A vault.
2. **Architectural Plans for the Building and Green Space:** PGE needs accurate architectural plans showing the building layout and elevations.
3. **A Site Geotechnical Report:** The customer must provide a site geotechnical report to PGE if a sub-grade vault location is requested.
4. **Grounding Method:** Before foundations are installed, a grounding method must be reviewed and confirmed by PGE.

A detailed list of required documents for commercial projects is available in section [1.5, Required Design Documents](#). Timely submission of this information allows for timely vault development by PGE.

1.5 Required Design Documents

PGE's design timeline is dependent on submission of all requested customer design documents selected by the DPM. Most projects require, but are not limited to, the following information/documents:

- Civil plans (e.g., street plans, grade, sidewalk, parking, and curbing details)
- Utility plans (e.g., existing and proposed utilities)
- Site plan with proposed meter locations showing—lot lines, easements, transformer vault location, and requirements
- Grading/elevation plans and profile
- Structural details with foundation, surface structures, utility vaults, and any other sub-grade structures (existing and/or proposed)
- Architectural plans showing the elevation of the building (awnings, balconies, etc.)
- Landscape plan (streets, trees, and irrigation)
- Electrical plans
- Switchgear location and review—see [Commercial Guide](#), section 3.1, Customer Gear Review
- PGE Area Light or Streetlight with a Street Improvement/Frontage Plan, if applicable
- Other documents as requested by the DPM or FCC



SCHEDULE: If changes arise in the municipal-approved Frontage Improvement Plan (if required), notify PGE as soon as possible. Email the updated document(s) and note, on the drawing and/or in an email, the updates made to the original.

1.6 Customer-Provided Equipment and Materials

The requirements and steps for designing and constructing a Class A vault are outlined and, where appropriate, illustrated in the following pages. Product references are included as examples. A project team can submit products with specifications equal to or greater than those listed for review by PGE's Standards Engineers and allow 90 days for review and approval. No alternate products should be procured before receiving written approval from PGE.

Failure to submit alternate equipment, materials, or plans to PGE before installation will delay or preclude the installation of PGE equipment and final service. Making changes to the Class A vault layout, dimensions, entrance (including objects/impediments to access outside of the Class A vault room), surroundings, equipment, or location during the design process without consulting PGE may result in delays in evaluation, as well as potential revocation of a "Will Serve" commitment.

1.7 Safety

Safety is the foremost concern in all of PGE's work. Class A vaults house one or more electrical transformers, which involve significant safety hazards to life and property. As an integral part of the structure, the Class A Vault must be constructed to protect the building, the occupants, and the PGE personnel who will service equipment in the Class A vault over its lifetime. PGE personnel need to be able to operate, maintain, and quickly replace electrical equipment that meets all national codes and company standards for occupational safety.

Vault design and layout must conform to the latest edition of the National Electrical Code (NEC), National Electrical Safety Code (NESC), National Fire Protection Association (NFPA) building codes, and local fire safety and building codes, as well as standards and requirements specific to PGE.

1.8 Accuracy of Information and Conflicting Requirements

Customers must ensure they have the current edition of the Class A Vault Guide.

IMPORTANT: Please consult PGE with questions regarding the applicability of any of this Guide's content.

The information in this Class A Vault Construction Guide is accurate at the time of publication and subject to change without notice. The requirements described herein are intended to comply with all governing codes, ordinances, and tariffs. However, these requirements will be updated if any of those codes, ordinances, and tariffs change. The more restrictive requirement governs if the information in this book conflicts with a code, ordinance, or tariff.

1.9 Summary of Architectural / Engineering Design Requirements

LOCATION OF PGE EQUIPMENT

Vehicle access available 5–15 feet from the vault.

Adjacent sidewalk located near the Class A Vault cannot have more than a 4% side slope or 2% slope from the building to the street or curb.

At-Grade Vault (PGE's Standard)—Ground level (a.k.a. “at-grade”) room within the building’s footprint, adjacent to an exterior wall, with minimum one 8-foot × 8-foot equipment/personnel doors to the exterior. Directly outside access doors, a 10-foot × 10-foot × 6-inch level reinforced concrete pad with 30-foot unimpeded vertical clearances directly above and 10-foot horizontal clearance to either side of the pad.

Sub-Grade Vault—If municipal codes prohibit an at-grade vault, and PGE agrees to a sub-grade vault, an access hatch and equipment hatch, with minimum clearances, are required at-grade in a PUE (public utility easement) or right-of-way. Egress doors within the vault must open onto a level, 8-foot-deep, direct-exit pathway as described above.

Electrical Room—Locate opposite the Class A vault transformer room with a shared wall and the same floor elevation.

VAULT ROOM

Two egress doors are required within the vault room. Doors must be 3-hour fire rated, metal.

- A rectangular or square room, without structural columns or supporting walls. No steps, lips, ramps, or non-PGE related transformation equipment are present in the room.
- Minimum room dimensions listed in [2.2, Vault Room Size \(Minimums\)](#), with a height between 13–15 feet.
- Within the vault room, PGE requires a 10-foot-wide clear pathway from the equipment access portal to any transformer to allow for installation and removal.
 - Transformers must be a minimum of 5 feet from walls and adjacent transformers.
- Transformers under 750 kVA are approximately 6 feet wide × 7 feet long; transformers over 750 kVA are 7 feet wide × 8 feet long.
- Room must contain a grounding system:
 - Select a structural ground system (see [3.1, Ground to Structure](#))
 - Design walls for working ground system 2 feet above finished floor (AFF) (see [3.2, Working Ground \(Equipotential Ground\)](#))
- Floors use rebar-reinforced, 12-inch concrete (5000 psi) capable of supporting the weight and movement of 16,000-pound transformers (see [3.3, Floor Construction](#)).
- A 1/16-inch-per-foot slope is required to a minimum 15-inch × 15-inch × 12-inch sump pit located in the corner of the vault nearest/directly under the personnel access hatch (sub-grade) or opposite the vault entry doors (at-grade).

VAULT WALLS

- Incoming primary conductor conduits (10 feet AFF for sub-grade vault)
- Block outs for connection bus(es), vents (sizes, locations, minimum 1 foot below vault ceiling)
- Burke clutch receivers at 12 inches AFF with number and locations TBD (these will be present on the customer’s Class A Vault Job Sketch jointly developed with PGE input)
- Burke clutch receiver at 10 feet AFF directly opposite primary conduits (if entering through the wall)
- 250 MCM continuous grounding loop at 24 inches AFF, secured to rebar, and attached to structural electrode ground tails.
- Brass grounding inserts (Lane Industries KBR R1238/26) attached to the continuous grounding loop at location(s) per approved vault plan (approximately 5 feet on center)
- Grounding insert(s) at personnel and equipment access hatches (sub-grade)

- Two Cadweld or crimp attachments per insert to 250 MCM loop at 5 feet centers and 24 inches AFF
- Inserts secured and flush with the finished wall
- Sleeves through columns, 3/8-inch threaded inserts 8 inches out from corners and at doorways
- Boxes and connecting conduits for wall lights (6 feet AFF), switches (4 feet AFF), outlets (3 feet AFF), and emergency egress lights
- Conduits run to the vault service panel location
- Sleeves for air conditioner line sets
- Fire sprinkler heads (where required by local Fire Marshall)
- Embedded 1-5/8-inch × 1-5/8-inch galvanized C-channel (Unistrut 8 feet per transformer mounted 48 inches AFF, directly above incoming primary conduits (at-grade vault) or below (sub-grade vault))

VAULT CEILING

- Grid of wood-form inserts (a.k.a. Simpson Strong Tie BBWF3762), 12 inches from walls and 24 inches on center in the field
- Design room for:
 - block out for exhaust fan/intake air
 - ferrules for D-ring fall arrest anchors
 - boxes and connecting conduits for heat detectors
 - boxes and connecting conduits for access hatch switches ((lights/exhaust fan/sump pump) (sub-grade vault))
 - Burke clutch receiver directly above primary conduits (if entering through the floor)

VAULT INTERIOR

- Proposed routing of cable tray with required ½-inch threaded down rods
- Plans show seismic reinforcing for cable trays and connection bus securement per supplier plan or seismic engineer. All tray joints should be trapezed
- Room designs incorporate plugs, switches, work lights, heat detectors, emergency egress lights, wall anchors, grounding inserts, and D-ring fall arrest hardware in room design
- Sump pit cover and drain line meet requirements in [Section 3.11.6, Sump Pump / Evacuation Piping for Oil Containment](#).
- Plans call for #6 grounding pigtailed attached to door frames, fire damper vents, and any accessible metal parts
- Vault service panel installed and labeled (NEMA 3 if sub-grade)
- Burke clutch receivers not protruding from the finished floor/walls and not filled with concrete
- Louvered 16-inch × 16-inch vent and 30-amp twist plug receptacle for exhaust fan above egress door
- No steps, lips, ramps, or non-vault equipment conduits are visible
- A/C heads and thermostat (directions for controlling thermostat and heads accessible)
- Plans include a personnel access ladder installed, secured, grounded (sub-grade)

VAULT LABEL

- Affix a PGE-supplied warning label for outside doors into vault (NEC 450)

2 General Design Process Considerations

2.1 Access

PGE's standard requirement is to locate the Class A Vault contain PGE's transformation at ground level in a room located on the exterior wall of the buildings with an 8-foot by 8-foot double equipment/personnel door within 5–15 feet of a drivable surface. Customers must create adequate space for PGE to house its equipment within the building footprint. When a local authority discourages a ground-level vault, PGE will consider the construction of the vault one floor below ground level (e.g., sub-grade).

To provide safe and reliable electrical service, the Class A vault must be accessible from outside the building, 24/7/365. Customers and/or property management firms will not have access to these rooms for cleaning, storage, maintenance, or any other use. If a customer needs to conduct maintenance of their building that involves the Class A vault, please contact PGE's Service Coordination team to schedule a Safety Standby crew (generally 3-week lead time).

IMPORTANT: Only electrical service equipment may be located inside the vault. Ducts and pipes not used for electric service must not pass through the vault area. Refer to NEC 450.

PGE will review requests to locate a Class A vault in locations other than adjacent to an exterior wall of the building. Requests for interior installations are usually denied. If PGE approves an exception, the customer will install PGE-issued lockbox(es) and provide a key for each locked door that must be passed through to gain access to the vault.

2.2 Vault Room Size (Minimums)

PGE has final approval of a customer's Class A vault location and configuration. Approval is dependent on the requested services and structural impediments.

PGE prefers Class A vault rooms with these characteristics:

- a rectangular or square space.
- rooms sharing a wall with the electrical switchboard room and at the same floor elevation.
- rooms without structural columns, shear, or supporting walls.

The room characteristics above support the following minimum vault sizes:

| Number of Transformers and Services | Room Size |
|--|-----------------------------|
| Single transformer for one service gear | 20' D × 20' W × (13–15' H)* |
| Two transformers for two service gears | 25' D × 35' W × (13–15' H) |
| Three transformers for three service gears | 25' D × 45' W × (13–15' H) |
| Four transformers for four service gears | 25' D × 50' W × (13–15' H) |

* Rooms with a single transformer vary in room size, with PGE requiring 15' D × 20' W, 20' D × 20' W, and 25' D × 20' W.

The presence of columns, beams, or differences in room elevations can all impact the amount of room and clearance required to install vault equipment. The actual room size depends on PGE's

determination of the equipment size required, and PGE's future ability to remove and reinstall any one piece of equipment without disconnecting or disturbing any other pieces in the room.

Additional requirements for sub-grade vaults:

- An additional minimum 8-foot × 10-foot equipment access shaft, a 5-foot × 5-foot personnel access shaft, with 5-foot clearances between the equipment and personnel access shafts (at-grade) on all sides, is required.
- The access shaft and at-grade hatches/doors can exist in the right-of-way (ROW). Where a ROW does not exist, additional space may be required in the vault. The portion of the vault containing the transformers and equipment must be contained within the project's property lines.

2.3 Electrical Room Location

PGE prefers the meter and electrical room at the same elevation and immediately adjacent to the Class A vault's long wall. For three- and four-transformer vaults, this configuration is not optional. This allows for a secondary conductor to be routed to the customer's switchgear efficiently.

This configuration is the most cost-effective and approved by most authorities having jurisdiction (AHJ). More information is available in NEC 230.70 and 230.72, as well as PGE's [Electric Service Requirements](#), Section 13.

2.4 Minimum Safety Clearances

These initial safety clearances are especially relevant to support customers' preliminary layout of equipment within their vault.

2.4.1 Transformers Minimum Safety Clearances

The following minimum safety clearances are required around transformers:

- Transformers must have an unimpeded, 10-foot-wide access corridor within the vault to allow for the installation or removal.
- Transformers must be at least 5 feet from walls, structural columns, and adjacent transformers. For reference, transformers under 750 kVA are approximately 5 feet wide × 6 feet long; transformers over 750 kVA are 6 feet wide × 7 feet long.

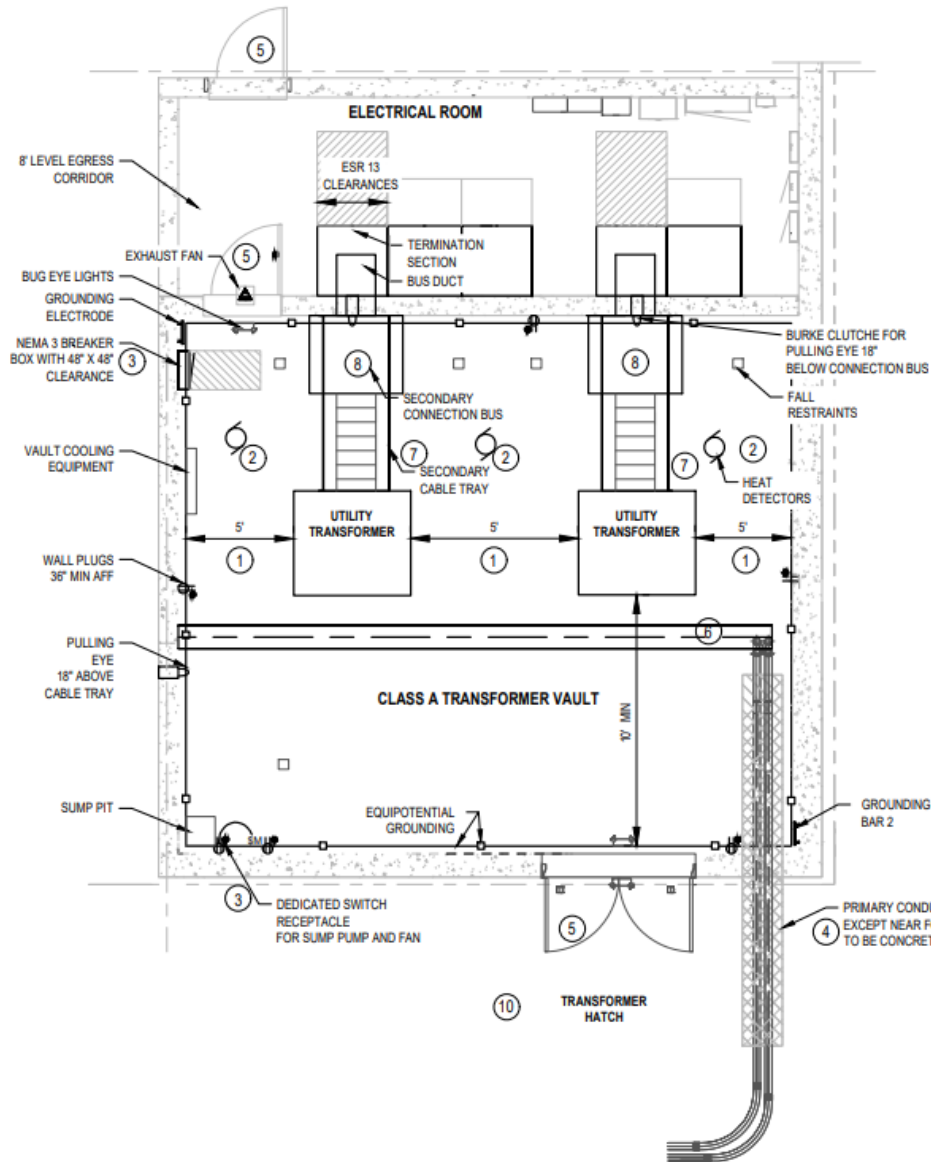

ELECTRICAL NOTES

1. UTILITY TRANSFORMERS MUST HAVE 5 FOOT CLEARANCES BETWEEN TRANSFORMERS, AND FROM THE TRANSFORMER TO THE WALLS.
2. PROVIDE FIRE ALARM SYSTEM CONNECTED TO RATE OF RISE HEAT DETECTORS PER PGE REQUIREMENTS.
3. NEMA 3 PANEL TO SERVE ELECTRICAL DISTRIBUTION WITHIN THE VAULT.
4. INCOMING UTILITY SERVICE CONDUCTORS. CUSTOMER TO PROVIDE SEALS AROUND PENETRATION OF CONDUCTORS, AND OTHER ANY NECESSARY WATER MITIGATION MEASURES.
5. DOORS MUST OPEN 180 DEG. TO FOLD FLAT AGAINST THE BUILDING. DOORFRAMES MUST BE BONDED AND DOORS MUST HAVE PANIC EGRESS HARDWARE. ROOM ACCESS (KEYS AND LOCKBOXES) MUST MEET PGE REQUIREMENTS (ESR 13).
6. NON-METALLI CABLE TRAY FOR INCOMING PRIMARY UTILITY FEED. SUSPEND AT 9 FEET AFF. CABLE TRAYS TO BE SEISMICALLY RATED.
7. NON-METALLIC TRAY FOR SECONDARY FEED. SUSPECT AT 7 FEET AFF. CABLE TRAYS TO BE SEISMICALLY RATED.
8. SECONDARY CONNECTION BUS. REFER TO PGE REQUIREMENTS.
9. LIGHTING INFORMATION IS REQUIRED, THOUGH ONLY BUG EYE LIGHTS ARE SHOWN IN THIS DRAWING.
10. BURKE CLUTCHES WILL BE REQUIRED OUTSIDE THE BUILDING.

Figure 1. Overhead View of an At-Grade Class A Vault and Electrical Room (STD-D-6308-2)

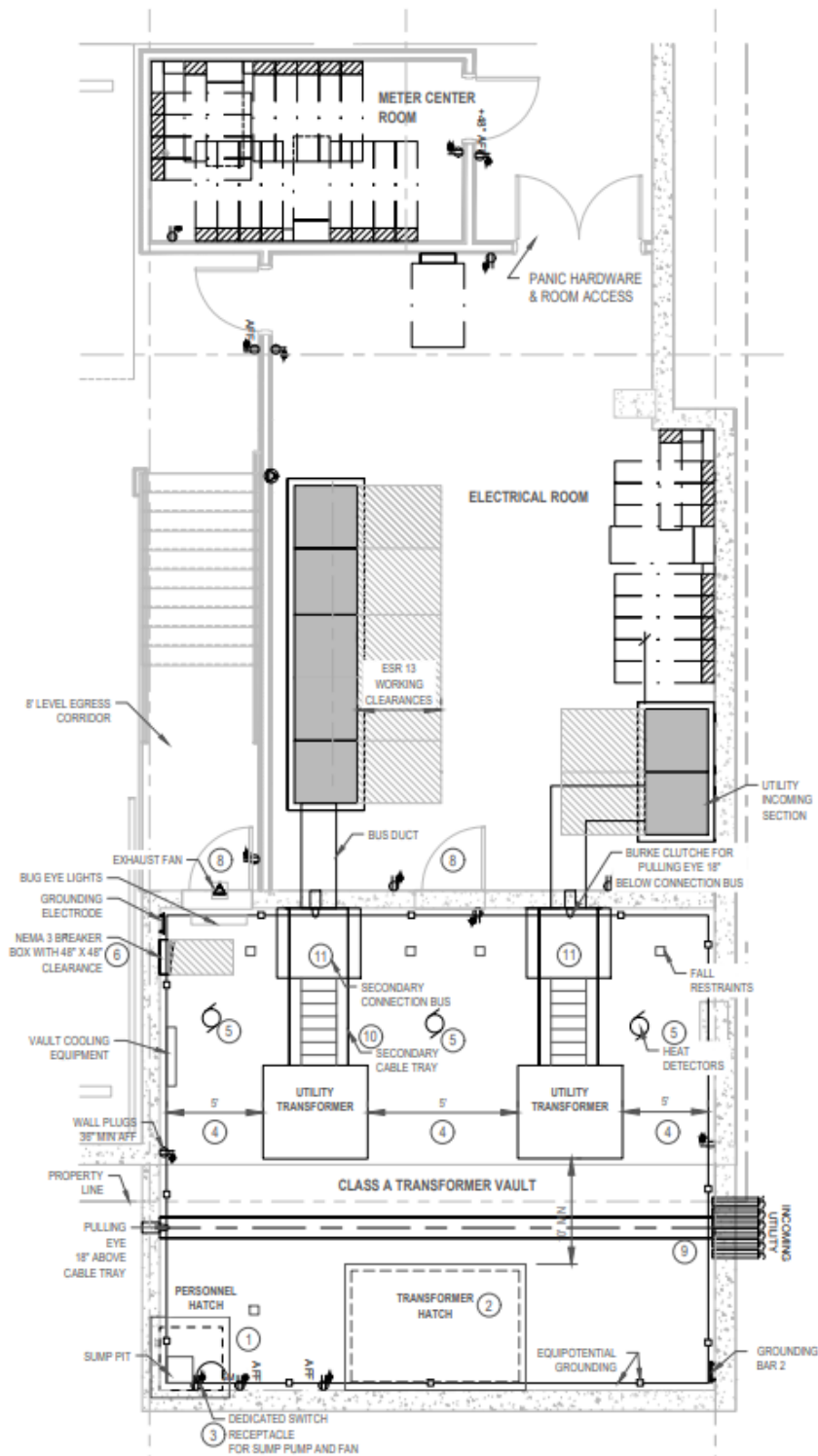

ELECTRICAL NOTES

1. PERSONNEL HATCH IN PUE OR PRIVATE PROPERTY, DEPENDING ON THE AUTHORITY HAVING JURISDICTION. PROVIDE A 3'X3' PERSONNEL HATCH WITH 5'X5' FRAME. MAINTAIN 3' CLEARANCE BETWEEN PERSONNEL AND EQUIPMENT HATCHES.
2. EQUIPMENT HATCH IN PUE OR PRIVATE PROPERTY, DEPENDING ON THE AUTHORITY HAVING JURISDICTION. PROVIDE A 6' BY 8' EQUIPMENT HATCH WITH A 8' X 10' FRAME. MAINTAIN 3' OF CLEARANCE BETWEEN PERSONNEL AND EQUIPMENT HATCHES.
3. LOCATE SUMP PUMP SWITCH BELOW PERSONNEL HATCH WITHIN ARMS REACH.
4. UTILITY TRANSFORMERS MUST HAVE 5 FOOT CLEARANCES BETWEEN TRANSFORMERS, AND FROM THE TRANSFORMER TO THE WALLS.
5. PROVIDE FIRE ALARM SYSTEM CONNECTED TO RATE OF RISE HEAT DETECTORS PER PGE REQUIREMENTS.
6. NEMA 3 PANEL TO SERVE ELECTRICAL DISTRIBUTION WITHIN THE VAULT.
7. INCOMING UTILITY SERVICE CONDUCTORS. CUSTOMER TO PROVIDE SEALS AROUND PENETRATION OF CONDUCTORS, AND OTHER ANY NECESSARY WATER MITIGATION MEASURES.
8. DOORS BONDED WITH PANIC HARDWARE. ROOM ACCESS (KEYS AND LOCKBOXES) MUST MEET PGE REQUIREMENTS (ESR 13).
9. NON-METALLI CABLE TRAY FOR INCOMING PRIMARY UTILITY FEED. SUSPENSND AT 9 FEET AFF. CABLE TRAYS TO BE SEISMICALLY RATED.
10. NON-METALLIC TRAY FOR SECONDARY FEED. SUSPECT AT 7 FEET AFF. CABLE TRAYS TO BE SEISMICALLY RATED.
11. SECONDARY CONNECTION BUS. REFER TO PGE REQUIREMENTS.
12. LIGHTING INFORMATION IS REQUIRED, THOUGH ONLY BUG EYE LIGHTS ARE SHOWN IN THIS DRAWING.

Figure 2. Overhead View of a Sub-Grade Class A Vault and Electrical Room (STD-D-6308-1)

2.4.2 Connection Bus(es) Minimum Safety Clearances

The minimum safety clearances required around connection bus(es) include the following:

- Bus(es) must be a minimum of 5 feet from adjacent walls or bus(es) and no more than 6 inches from the shared electrical room wall. A bus is 4 feet wide by 4 feet deep by 15 inches tall.

2.4.3 Doors and Clearances

PGE requires two emergency egress routes on opposite sides of Class A vaults. PGE requires vault doors to meet the following requirements:

- Due to the ARC flash rating of transformers, the doors may not be made of or contain glass, plastics, or combustible materials; they must be 3-hour fire rated.
- Doors should be 36 inches × 80 inches and open outward onto a level, 8-foot-deep direct-exit pathway.
- All exit doors must be installed with panic hardware. If doors are equipped with a center striker bar, the striker bar must be secured with recessed floor nuts below floor grade.
- All door lock cores will be keyed by PGE's authorized locksmith, Atlasta Lock & Safe, 503-233-8761. Keying must occur prior to PGE installing equipment in the Class A vault.

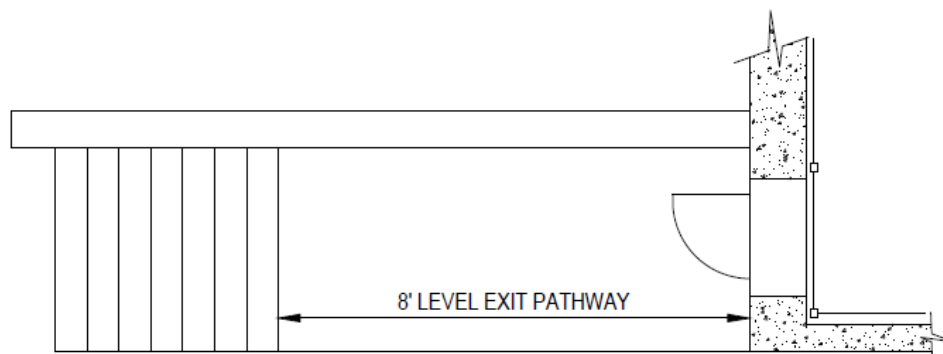

Figure 4. 8-Foot Level Egress Corridor (STD-D-6300)

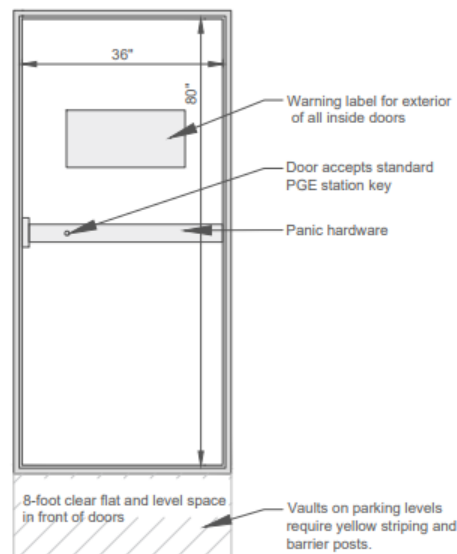

Figure 5. Door Requirements

2.4.4 Equipment and Personnel Access for At-Grade Vaults

At-grade vaults typically have the following doors:

- A 36-inch emergency egress door with panic hardware with an 8-foot level exit pathway, and

- An 8-foot × 8-foot double door for equipment and emergency egress

When vault access is on an exterior wall, the following minimum safety clearances are required:

- The vault must have an 8-foot × 8-foot double door(s) with panic hardware. Center mullions and threshold plates must be removable for transformer installation and have recessed floor anchors.
- Directly outside the doors must be a minimum 10-foot × 10-foot × 6-inch level reinforced concrete pad with 30-foot unimpeded vertical clearance directly above and 10-foot horizontal clearance to either side of the pad. The clearances must be free of tree canopies at maturity. A minimum of two rigging anchors in the sidewalk will be required, typically at the back of the curb.

NOTE: In some municipalities, PGE may not be able to locate equipment doors on the active frontage. In those instances, the customer must provide a minimum continuous 10-foot-wide access corridor (a.k.a. hallway) directly outside the vault equipment doors to 8-foot by 8-foot double-entry doors on the building active frontage. PGE may require the installation of rigging anchors (see below) in the corridor floor or wing walls to either side of the doorways.

- PGE's authorized locksmith will key all door lock cores, Atlasta Lock & Safe, 503-233-8761. Keying must occur prior to PGE installing equipment in the Class A vault.



Figure 6. Equipment Access Double Doors for At-Grade Vaults

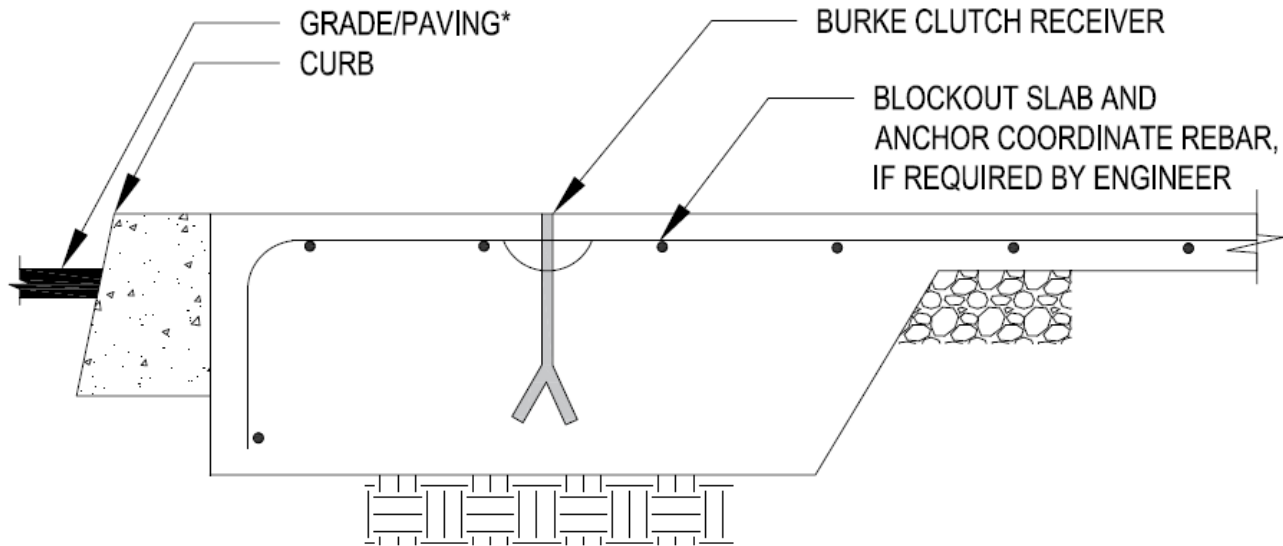

* SIDEWALK MUST WITHSTAND THE WEIGHT OF PGE'S TRANSFORMER(S).
 MAXIMUM SLOPE OF SIDEWALK PARALLEL TO CURB IS 4% AND PERPENDICULAR
 FROM BUILDING TO CURB IS 2%.

Figure 7. Spread Anchors Installed in Sidewalk (STD-D-6302)

2.4.5 Equipment and Personnel Access for Sub-Grade Vaults

Sub-grade vaults are required to have the following elements:

- Two emergency egress doors on opposite sides of the Class A vault room; this is required when there are multiple transformers.
- At sidewalk grade, there must be a personnel access hatch and one equipment access hatch.

The following minimum safety clearances are required around personnel/equipment access hatches:

- Clearance of 5 feet is required around all four sides of the opening.
- See [Appendix B, Personnel Hatch Specification \(3-Foot × 3-Foot Doors\)](#), and [Appendix C, Equipment Access Hatch](#) for material manufacturer information.

| Type of Hatch | Total Size | Opening Size |
|------------------------|--------------|--------------|
| Personnel hatch | 5' × 5' | 3' × 3' |
| Equipment access hatch | 8' W × 10' L | 6' × 8' |



Figure 8. Equipment Access Hatches for Sub-Grade Vaults
Foreground: Equipment Access Hatch; Background: Personnel Hatch (a.k.a. Man Door)

2.5 Grades

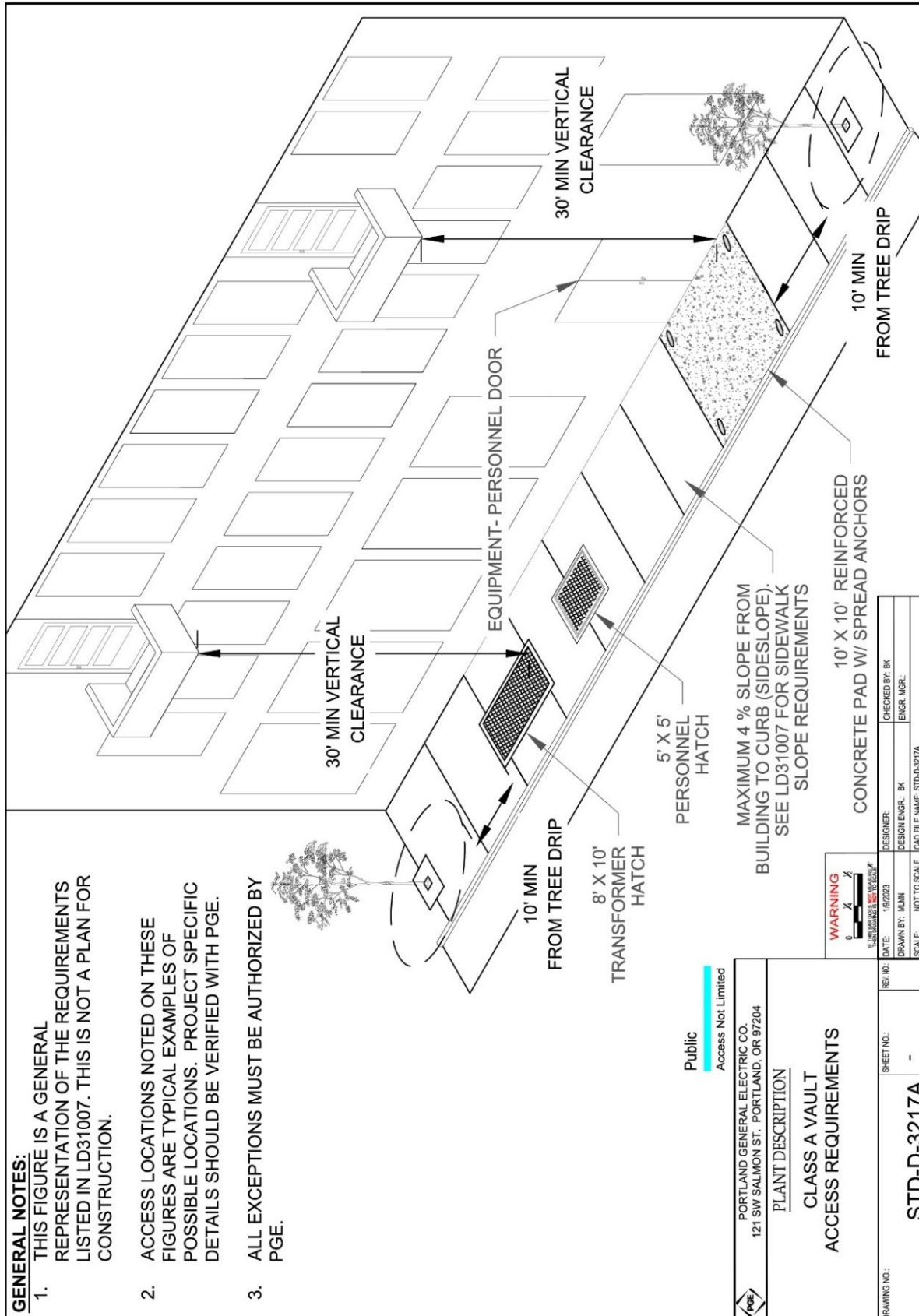

Figure 9. Class A Vault Vertical Clearance Requirements

3 Standard Construction Sequence Elements

PGE's grounding system has two elements to meet NEC 250 (PGE Standard LD31007): a UFER ground and a working (equipotential) ground. These two elements are part of one grounding system. Both are required before concrete is poured.

3.1 Ground to Structure: UFER

Customers have multiple options to achieve grounding for their Class A Vaults. A ground to the structure must contain grounding electrodes as defined in NESC 094-B and NEC 250.52 (see detailed requirements in LD31007).

The following are several common grounding methods used by customers.

3.1.1 Grounding Method: 250 MCM Bare-Stranded Copper Connections

Customers can install 250 MCM bare-stranded copper conductor in two vault corners, which must be exothermically Cadwelded to extension plates in two places with a minimum 12 inches of separation. The grounding extension plates must be welded to two of the structure's steel piles, with a minimum of 10 feet separation between piles. The extension plates should extend into the center of the vault wall while the extension tube provides for easier waterproofing of the penetration.

Grounding plate extensions require an 8-inch × 8-inch × ¼-inch base plate, 4-inch diameter × ¼-inch thick extension tubing, and a 28-inch × 8-inch × ¼-inch plate. Continuous welds must join all components.



Figures 10 and 11. 8-inch × 8-inch × ¼-inch Base Plate, 4-inch Diameter × ¼-inch-Thick Tubing, and 28-inch × 8-inch × ¼-inch Plate

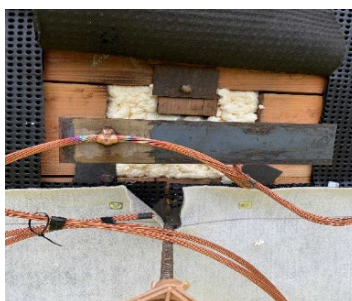
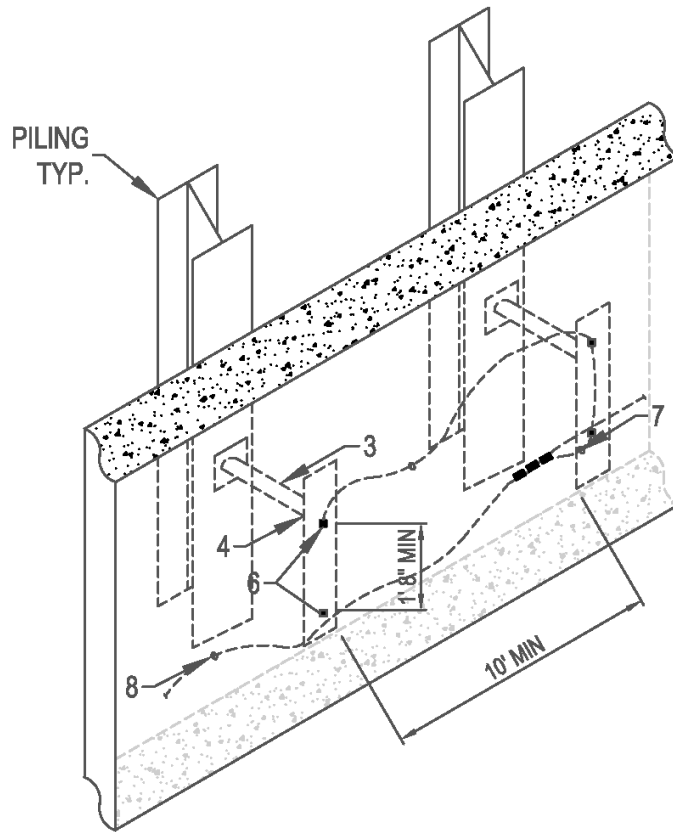

Figure 12. Components Joined by a Continuous Weld

NOTE: [Figure 12](#) only has one weld but should have two welds.



NOTES

1. ALL WELDS MUST BE GROUNDED CLEAN PRIOR TO WELDING.
2. SOLDIER PILING MUST BE PREPARED PRIOR TO WELDING.

KEYNOTES

1. 8"X8"X1/4" STEEL PLATE WELDED COMPLETELY AROUND THE OUTER EDGE TO A CLEAN SURFACE OF THE SOLDIER PILING.
2. 4" DIAMETER X 1/4" THICK STEEL TUBE WELDED COMPLETELY AROUND THE OUTER EDGE TO CENTER OF 8"X8"1/4" STEEL PLATE. LENGTH OF TUBE WILL VARY DEPENDING ON CONCRETE WALL THICKNESS, FIELD COORDINATE EXACT LENGTH.
3. WATER PROOFING AROUND STEEL TUBE BY OTHERS.
4. 8"X20"1/4" STEEL PLATE WELDED TO 4" STEEL TUBE, LOCATED AT CENTER OF CONCRETE WALL.
5. PROVIDE 250-KCMIL COPPER GROUND TAIL BETWEEN THE TWO SOLDIER PILING EXTENSION PLATES ENCASED IN THE CONCRETE WALL. CAD WELD TO SOLDIER PILING EXTENSION PLATES PER DETAILS IN NOTE 6.
6. 2" CAD WELD CONNECTIONS SHALL BE MADE 4" IN FROM OUTER EDGE OF PLATE AND SEPARATED A MINIMUM OF 12" APART.
7. EXTEND 25-KCMIL COPPER GROUND TAIL FROM SOLDIER PILING CONNECTION TO 250-KCMIL CONTINUOUS COPPER LOOP. CONNECT VIA A MINIMUM OF (3)2" CADWELDS OR (2) BURNDY YGH29C29 IRREVERSIBLE GROUND CRIMP.
8. 250-KCMIL CONTINUOUS COPPER LOOP ENCASED IN THE CONCRETE WALLS.

Public

Access Not Limited

PAGE SETUP: ADOBE PDF | LETTER



PORTLAND GENERAL
ELECTRIC CO.
121 SW SALMON ST.
PORTLAND, OR 97204

**CLASS A VAULT
UFER BONDING
HORIZONTAL LAYOUT**

DOCUMENTS CLASS A VAULT GUIDE
CROSS REFERENCED:

WARNING

IF THIS BAR CODES NOT MEMBERSHIP THEN IMPORTING IS NOT TO SCALE

DATE: 7/10/2023
DRAWN BY: MENDEZ-NUNEZ
SCALE: NOT TO SCALE

DEPARTMENT: STANDARDS

BUSINESS PARTNER:
FCCA, DPMA, METER ENGINEERING,
METERMEN

DRAWING NO.:

STD-D-6310

STD-D-6310.DWG | 8/26/2023 8:26:52 AM | MARIE MENDEZ-NUNEZ

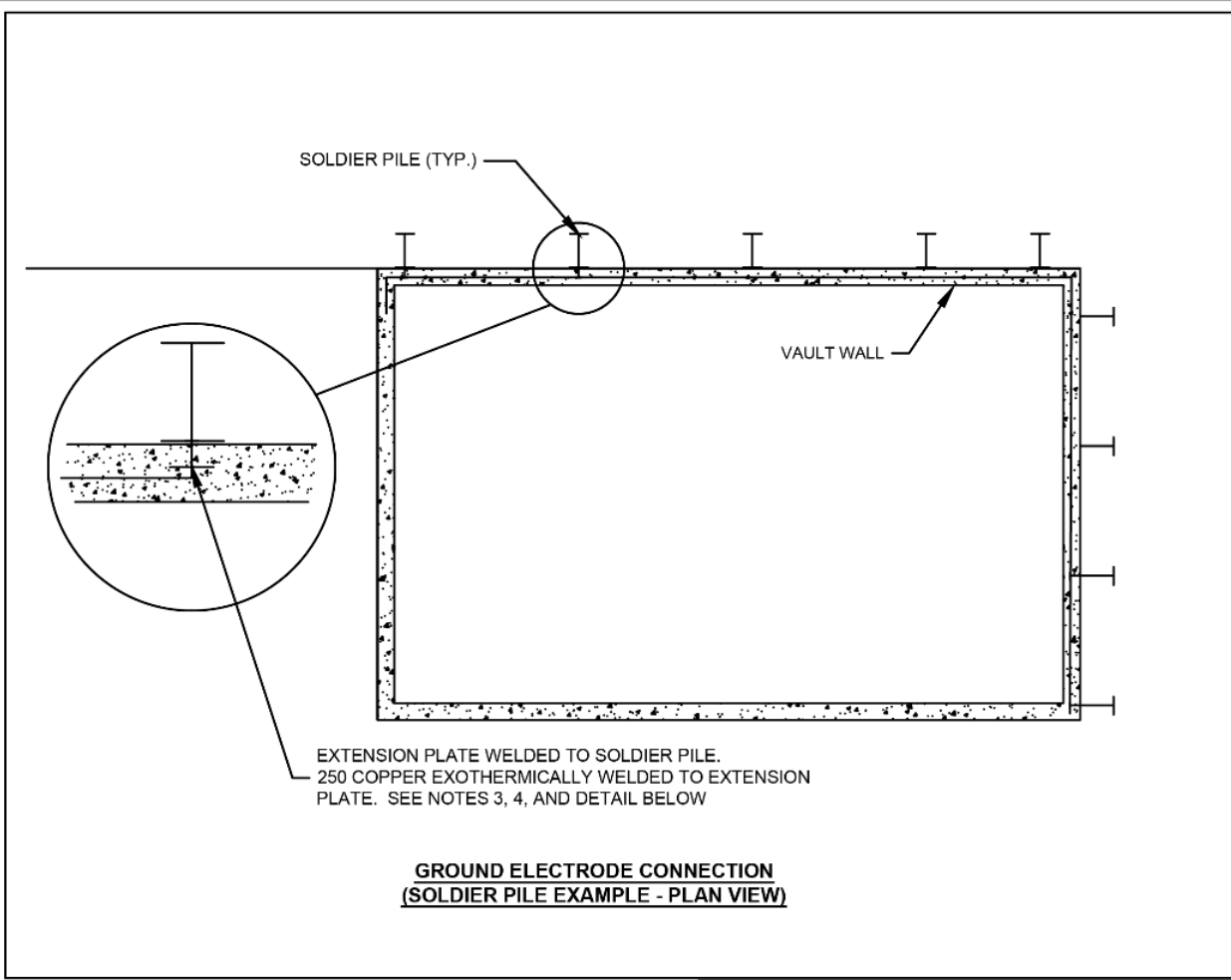

**GROUND ELECTRODE CONNECTION
(SOLDIER PILE EXAMPLE - PLAN VIEW)**

GENERAL NOTES:

1. THESE FIGURES ARE A GENERAL REPRESENTATIONS OF THE REQUIREMENTS LISTED IN LD31007. THIS IS NOT A PLAN FOR CONSTRUCTION. REFER TO LD31007 FOR SPECIFIC INFORMATION
2. EACH GROUND CONNECTION MUST BE MADE BY A CONTINUOUS 250 KCMIL, BARE-STRANDED COPPER WIRE (250 COPPER) WITH TWO EXOTHERMIC WELDS AT EVERY CONNECTION.
3. EACH RUN OF 250 COPPER MUST BE EXOTHERMICALLY WELDED DIRECTLY TO THE ELECTRODES AT TWO PILES OR PIERS AT OPPOSITE CORNERS OF THE VAULT. THE POINTS SHALL BE SPACED A MINIMUM OF 10 FEET APART AND CONNECTED INTO VAULT'S EQUIPOTENTIAL GROUND LOOP.
4. EXTENSION PLATE IS TYPICALLY A 8"X8" STEEL PLATE WELDED TO 4" Ø STEEL TUBE (1/4" THICK) WELDED TO 24"X24" STEEL PLATE. LENGTH OF TUBE IS DETERMINED BY VAULT WALL THICKNESS.
5. CUSTOMER IS RESPONSIBLE FOR ALL WATER SEALING OF WALL PENETRATIONS.
6. ALL EXCEPTIONS MUST BE AUTHORIZED BY PGE.

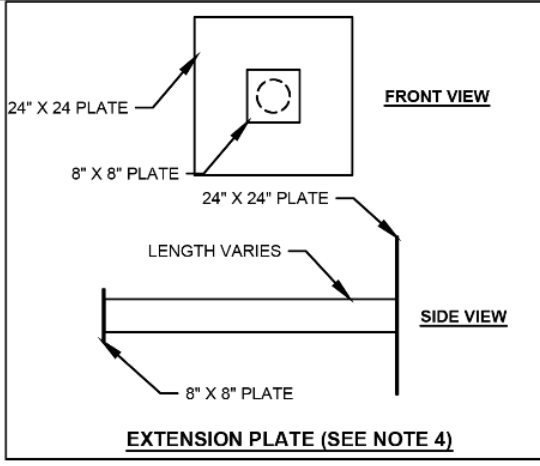

Public
Access Not Limited

PAGE SETUP - AUTOCAD PDF (GENERAL DOCUMENTATION) PC31.ANSI FULL BLEED A (8.50 X 11.00 INCHES)

PORTLAND GENERAL
ELECTRIC CO.
121 SW SALMON ST.
PORTLAND, OR 97204

**CLASS A VAULT
GROUND ELECTRODE CONNECTION**

DOCUMENTS LD31007
CROSS REFERENCED:

WARNING
IF THIS BAR DOES NOT MEASURE UP TO THE STANDARD, DO NOT USE.

DATE: 1/11/2023
DRAWN BY:
SCALE: NOT TO SCALE

DEPARTMENT: STANDARDS
BUSINESS PARTNER:
NONE

DRAWING NO.:
STD-D-6015-A

STD-D-6015.DWG | 2/15/2023 4:49:17 PM | BOBBY KOSOWSKI

3.1.2 Grounding Method: Slab on Grade Vault

This option must have a ground rod array or legs of 250 MCM secured to a rebar cage, continuous to the bottom of “drilled and cast-in-place piles.”

Customers can install slab on grade vaults using a series of driven 5/8-inch × 10-foot ground rods with Cadwelded 250 MCM copper tails connected to a 250 MCM copper loop with Cadwelds or crimps, supported in the rebar floor mat and connected by Cadwelds or crimps to 250 MCM copper tails that extend into the vault wall in two locations a minimum of 10 feet apart to form a continuous loop inside the vault walls. The overall square footage of the vault determines the number of ground rods in the array.

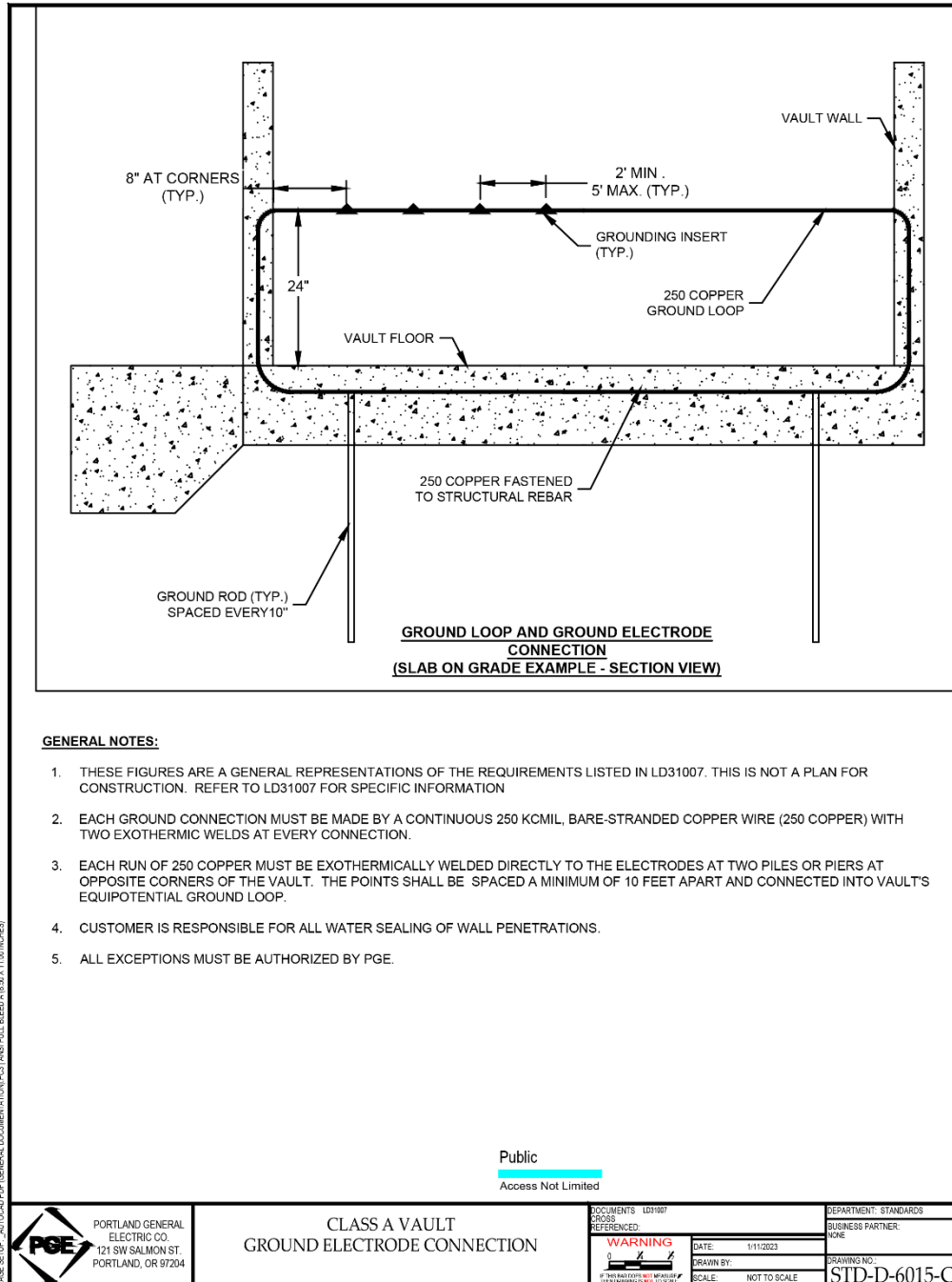
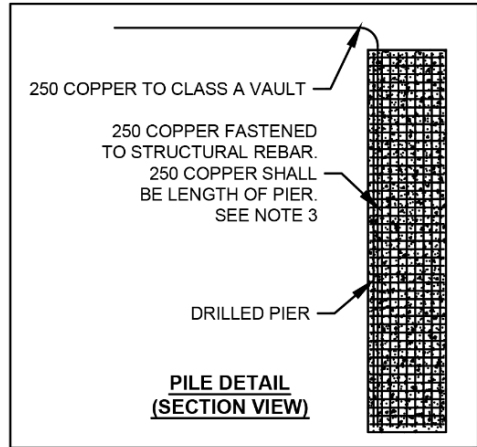
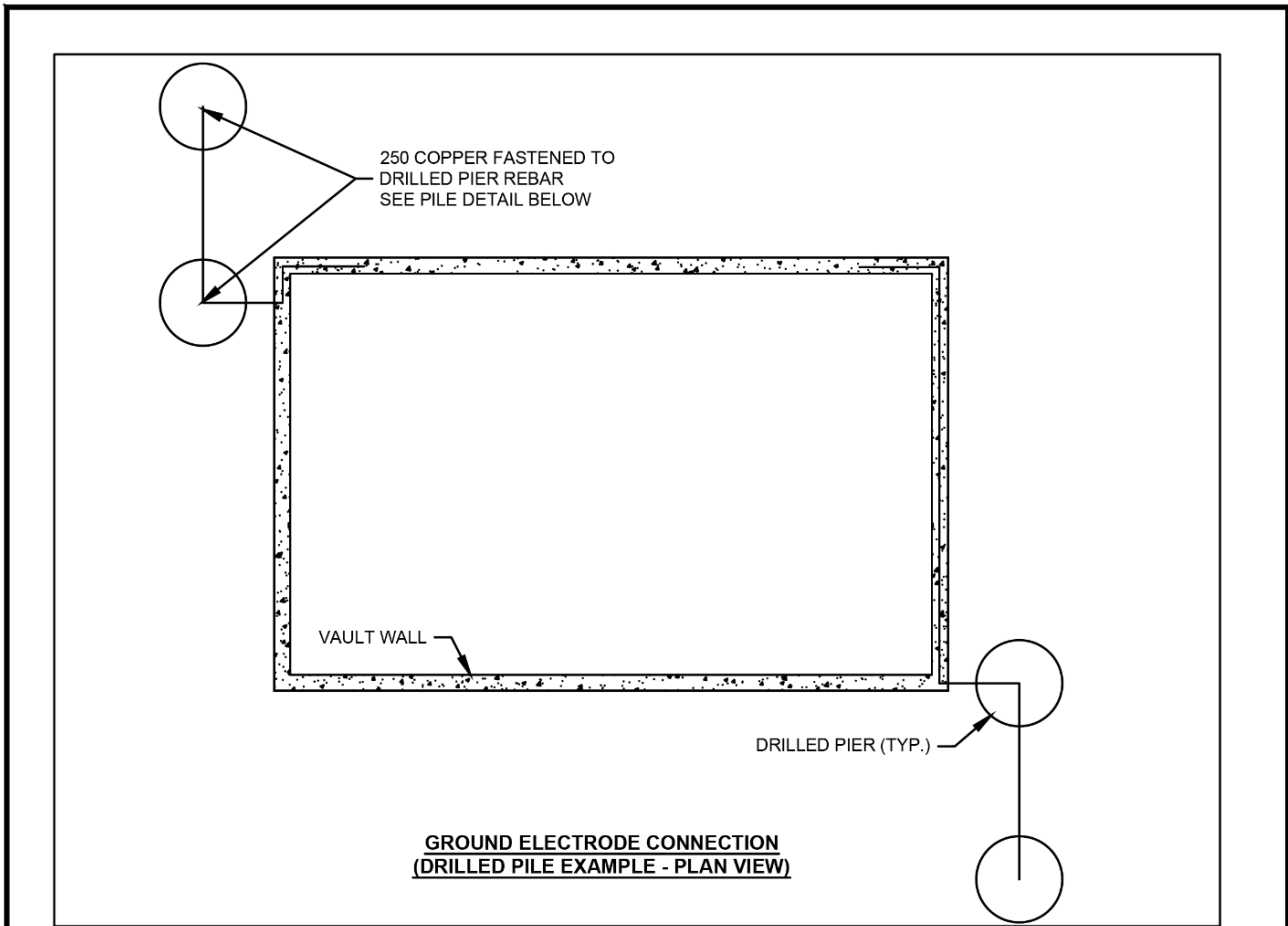

Figure 13. Slab on Grade Vault

3.1.3 Grounding method: Drilled Piers



GENERAL NOTES:

1. THESE FIGURES ARE A GENERAL REPRESENTATIONS OF THE REQUIREMENTS LISTED IN LD31007. THIS IS NOT A PLAN FOR CONSTRUCTION. REFER TO LD31007 FOR SPECIFIC INFORMATION
2. EACH GROUND CONNECTION MUST BE MADE BY A CONTINUOUS 250 KCMIL, BARE-STRANDED COPPER WIRE (250 COPPER) WITH TWO EXOTHERMIC WELDS AT EVERY CONNECTION.
3. EACH RUN OF 250 COPPER MUST BE EXOTHERMICALLY WELDED DIRECTLY TO THE ELECTRODES AT TWO PILES OR PIERS AT OPPOSITE CORNERS OF THE VAULT. THE POINTS SHALL BE SPACED A MINIMUM OF 10 FEET APART AND CONNECTED INTO VAULT'S EQUIPOTENTIAL GROUND LOOP.
5. CUSTOMER IS RESPONSIBLE FOR ALL WATER SEALING OF WALL PENETRATIONS.
6. ALL EXCEPTIONS MUST BE AUTHORIZED BY PGE.

Public
Access Not Limited

PAGE SETUP - AUTO CAD PDF (GENERAL DOCUMENTATION) PCS1 (ANSI FULL BLEED) A (8.5X 11.0) INCHES

STD-D-6015.DWG | 2/15/2023 4:46:26 PM | BOBBY KOSOWSKI

PORTLAND GENERAL ELECTRIC CO.
121 SW SALMON ST.
PORTLAND, OR 97204

CLASS A VAULT
GROUND ELECTRODE CONNECTION

DOCUMENTS LD31007
CROSS REFERENCED:

WARNING
IF THIS BAR CODES NOT MEASURED FROM HOW TO SCALE

DATE: 1/11/2023
DRAWN BY:
SCALE: NOT TO SCALE

DEPARTMENT: STANDARDS
BUSINESS PARTNER:

NONE
DRAWING NO.:
STD-D-6015-B

3.2 Working Ground (Equipotential Ground)

For worker safety, PGE requires a working ground (equipotential grounding) using a 250 MCM bare-stranded continuous copper loop in poured vault walls at 24 inches AFF and completely encased a minimum of 6 inches within the vault's concrete walls.

The connection points to the ground loop must be tied to structural rebar, with machined bronze grounding insert rods (KBR Industries #RS1238-26), placed 8 inches from corners and 5 feet on-center in walls, 24 inches AFF, and installed flush with the vault wall, facing toward the center of the vault. Each rod is secured to 250 MCM copper with two Cadwelds, or two approved crimps, per insert.

Each insert must have a protective plastic cap to prevent damage to the threads.

IMPORTANT: If structural columns are present in the vault, the customer will install means and methods to allow the internal ground ring to be constructed.

See [Appendix D, Ground Insert Specification](#), for manufacturer and ordering information.



Figure 14. Grounding Inserts

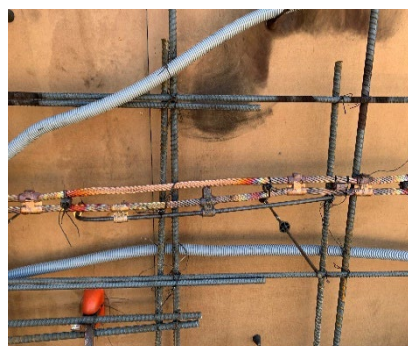

Figure 15. Cadweld Connection Options



Figures 16 and 17. Crimps and Cadweld Connection Options



Figure 18. Crimp Tool

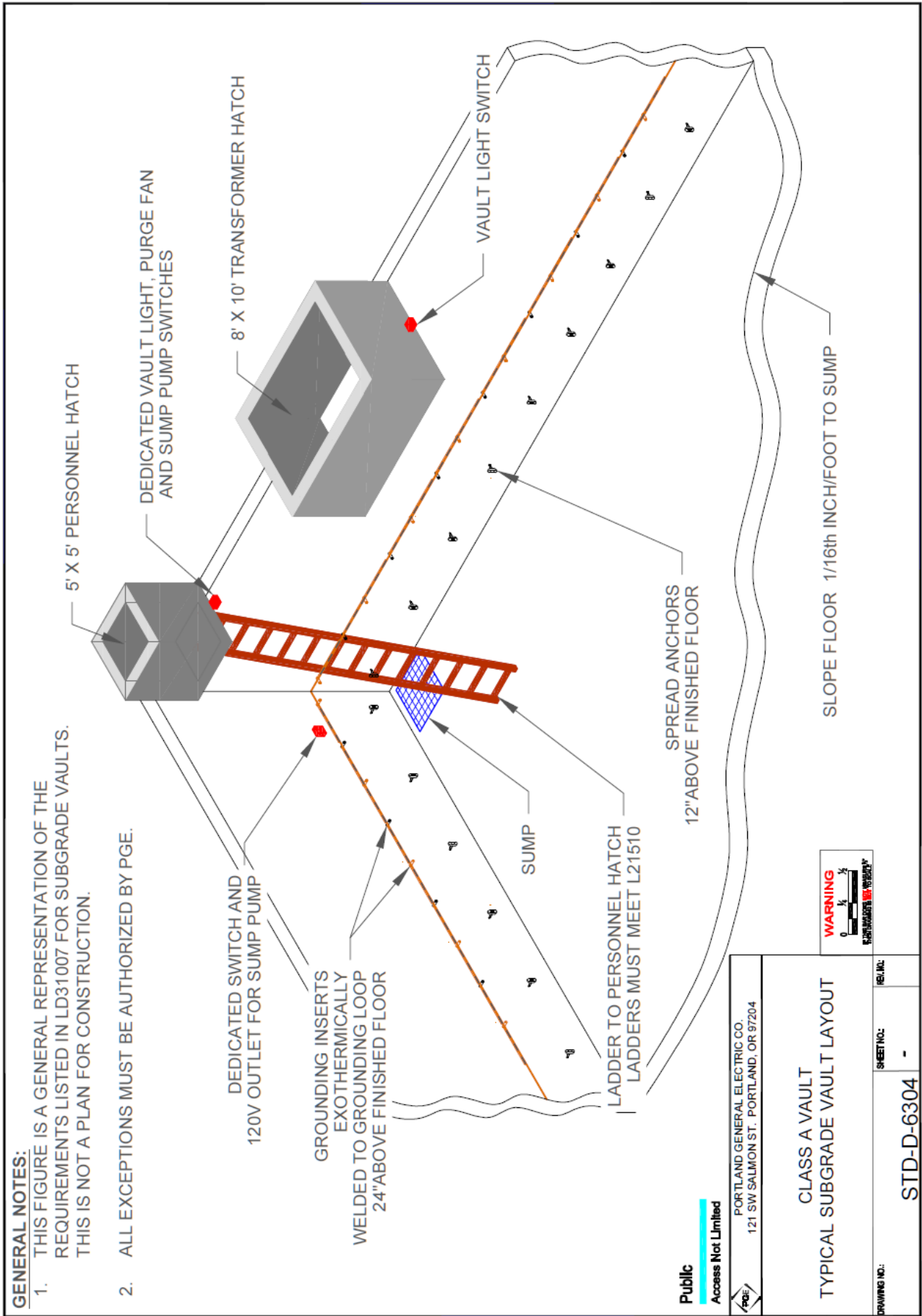

Figure 19. Equipotential Grounding

3.3 Floor Construction

The flooring construction requirements are as follows:

- Ensure no steps, ramps, or lips inside of or directly outside the Class A vault egress points.
- Customers must design the structural floor strength to support the total weight of the transformers and equipment. Typically, this means rebar-reinforced, with a minimum of 12-inch concrete (5000 psi) capable of supporting the weight and movement of 16,000-pound transformers and equipment.
- Floors must have a 3-hour fire-resistance rating.
- A 1/16-inch-per-foot slope is required to a sump pit that can contain the maximum volume of the largest transformer that could ever be installed. It should be located in the corner of the vault nearest/directly under the personnel access hatch (sub-grade) or opposite the vault entry doors (at grade). See additional details for the grate and sump pump connection in [Section 3.11.6. Sump Pump / Evacuation Piping for Oil Containment](#).
- Installation of recessed spread anchors (i.e., Meadow-Burke clutch receivers (RL-23/#79319/12K#)) for rigging of equipment. See [Section 3.6, Rigging Anchors](#), for spread anchor details.
- Finish the floor with a smooth, hard-troweled finish. PGE recommends that Class A vault floors be sealed to prevent water intrusion.

3.4 Wall Construction

Due to the hazards of in-building transformers, PGE requires Class A vaults to be constructed to meet a 3-hour fire rating. The wall construction requirements are as follows:

- Walls must be 12 inches minimum, typically made of formed and poured concrete that is 5000 psi as defined in ACI 318 with a 3-hour fire rating. Cinderblock, shotcrete, or sprayed concrete are prohibited.
- Foreign unapproved pipes, conduits, conductors, and/or openings are prohibited unless they are servicing PGE equipment within the vault. PGE must give written approval for their presence. Any exposed metal piping is not allowed within a vault.
- Install and connect an equipotential grounding loop, including grounding hubs, to the structural ground system.
- Before pouring the walls, install spread anchors (Meadow-Burke clutch receivers (RL-23/#79319), the same as the floor) for rigging at 12 inches above the finished floor (AFF).
- Install boxes for switches, outlets, lights, heat detectors, and all connecting conduits within the concrete wall.
- Install fire sprinkler heads if required by the local jurisdiction. See the picture in [Section 3.8, Fire Suppression](#). PGE does not require sprinklers.
 - Install 1-5/8-inch by 1-5/8-inch galvanized C-channel (e.g., Unistrut) for mounting of isolation laterals. The project's Field Construction Coordinator (FCC) will confirm the location(s) where one 8-foot bar is required for each transformer. The channel is installed at 48 inches

AFF. A 24-inch-wide cable tray is installed directly above (9 feet AFF) and parallel with the channel during the vault final construction.

3.5 Primary Conduit Entrance

Customers are responsible for supplying ducts from the property line to the building and must be Schedule 40 gray PVC. The size of the primary ducts will be listed on the PGE Job Sketch. The design must meet LD31010 and LC20515.

Primary Entrance for At-Grade Vaults—Primary conduits enter an at-grade vault through the floor, adjacent to the isolation lateral wall, and then travel up the wall and onto primary cable trays to the transformer(s).

Primary Entrance for Sub-Grade Vaults—Primary conduits enter sub-grade vaults from a vault sidewall at 10 feet AFF. Primary conduit penetrations should be a minimum of 4 inches between the outside conduit walls to allow for water sealing. Core drilling conduit penetrations is not acceptable. The conductor is routed down to the isolation laterals and then up to a series of cable trays mounted at 9 feet AFF terminating at the transformer.

Primary Laterals—PGE requires primary laterals to allow for a point of isolation within the vault. They are located at 4 feet AFF with a required working clearance of 10 feet clear space in front of them. The 1-5/8-inch by 1-5/8-inch Unistrut must be 8 feet in length. One primary conduit and Unistrut is required for each transformer. The Unistrut should not be stacked vertically. The project's FCC will assist the customer in identifying locations.

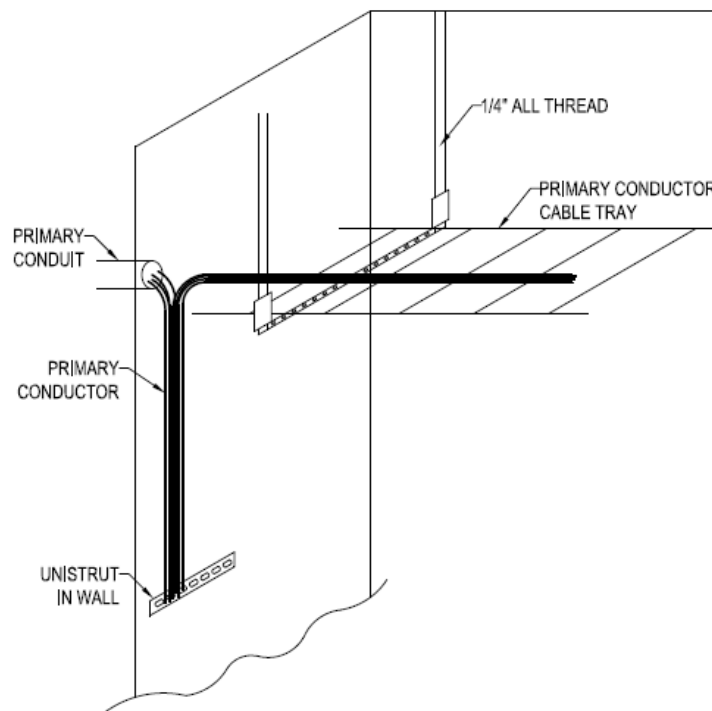

Figure 20. Primary Laterals with Point of Isolation in a Sub-Grade Vault(STD-D-3223)

3.6 Rigging Anchors

PGE utilizes embedded spread anchors (Burke clutch receivers), also called “pulling irons,” to maneuver transformers into place and/or to remove them from the Class A vaults when necessary.

The anchors must be recessed within the vault walls and floor and capable of supporting a working capacity of 10,000 pounds. This precludes non-reinforced concrete walls or floors less than 12 inches thick or sub-grade sidewalk spread footings less than 12 inches thick (see [Wall Construction requirements](#)).

Spread anchors must be installed in vault walls, 12 inches AFF. The minimum installation locations include, but are not limited to, the following:

- 3 feet on either side of the centerline of the transformer location (1 foot from the outer dimension of the transformer)
- Opposing walls (four per transformer total)
- Opposite incoming primary conductor conduits (height of conduit entrances)
- Under each connection bus (24 inches below the block out for the bus). The connection bus is typically 12 feet, 6 inches AFF, so anchor would be at 10 feet, 6 inches AFF.
- One in the ceiling above incoming primary conduits when entering from the vault floor
- In floors, walls, or sidewalks as determined by PGE FCC for installing and removing equipment from the vault.

Certain room configurations may require additional locations beyond those listed.

See [Appendix E, Spread Anchor Specification](#), for manufacturer and ordering information.



Figure 21. Spread anchor receiver with mounting cup



Figure 22. Spread anchor receiver with removed mounting cup



Figure 23. Installed Spread Anchor Receiver

3.7 Lighting, Switches, and Outlets (Boxes and Connecting Conduits)

Lighting, switch, and outlet requirements are as following:

- All lighting, plugs, fans, pumps, and climate control devices are connected to a dedicated breaker panel inside the vault (see [Figure 25](#)). A NEMA 3 panel is required for all vaults. The breaker panel should be wired to the building backup generator when applicable and wall mounted (5 feet AFF and within 2 feet of an egress door). If a backup generator is not present, see additional requirements in section [3.12, No Backup Generator Present](#).
- Before the ceiling pour, install any connection boxes or connecting conduit runs for lights, switches, outlets, ceiling-mounted dual function maximum temperature heat detectors (194

degrees) and rate of rise heat detectors (15 degrees in 60 seconds) connected to the building's fire monitoring system.

- Install a 4-foot daylight (5000 K) LED lighting array, wall-mounted 6 feet AFF, typically 10 feet (based on customer's lighting assessment) end-to-end spacing, and controlled from any vault access point (3- or 4-way switches). Sub-grade lighting requires moisture-resistant LEDs.
 - Emergency egress 1100 lumen “bug-eye” lights, with battery backup, must be mounted above all egress doors and adjacent to the personnel access hatch if the vault is sub-grade. See [Appendix F, “Bug-Eye” Emergency Egress Lights Specifications](#), for manufacturer and ordering information.
- Install one dedicated 120 V GFCI-protected, switched outlet adjacent to, and 3 feet AFF at the sump pit. The switched outlet should be controlled at the equipment and egress doors when at grade. For subgrade vaults, the outlet should be controlled at both the personnel access hatch and at the egress door(s).
- Install one 120 V GFCI-protected outlet at each transformer location with a maximum of 15 feet of separation from adjacent walls.
- Install one 30 A dedicated twist plug receptacle for exhaust fan. The outlet and switching location(s) to be determined by PGE's FCC. The switched outlet should be controlled at: the personnel access hatch and at the egress door(s) when the vault is sub-grade.



Figure 24. 1100 L “Bug-Eye” Emergency Egress Lights



Figure 25. NEMA 3 Breaker Panel

NOTE: When a backup generator is not present, the breaker panel will require additional components for connection to a PGE portable generator.

3.8 Fire Suppression

PGE does not currently require active fire suppression in the Class A vault. Where required by a local jurisdiction the following limits are imposed by PGE:

- Sprinkler heads only; no surface-mounted piping allowed on vault walls.
- A manual sprinkler shut-off valve is required outside the egress door if sprinklers are present.
- See [3.11.5, Set Temp/Rate of Rise Heat Detectors Connect](#) for additional fire suppression measures.

3.9 Climate Control and Ventilation

Climate control and ventilation requirements are:

- Design and install a dedicated climate control system for the vault, separate from the buildings' main HVAC system, capable of maintaining a maximum vault temperature of 80 degrees; PGE can supply transformer BTU ratings.
- Install a controlling thermostat with operating instructions accessible inside the vault. The cooling appliance termination (“head”) is the only element allowed within the vault; no compressor or exposed connecting piping may be located within the vault. All line sets, condensation lines, etc., must run outside the vault walls. All line set penetrations must be 3-hour fire caulked.
- Obtain the PGE supplied fan, and brackets, from your Design Project Manager or Field Construction Coordinator. It is the contractor’s responsibility to mount the fan and louvered vent prior to PGE scheduling energization of the vault. See [Appendix G, PGE-Supplied Fan Specifications](#).



Figure 26. Mounted Cooling Heads

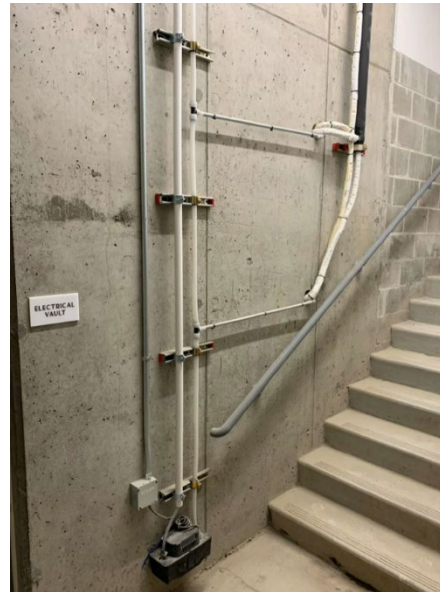

Figure 27. Cooling line sets mounted on the exterior of the vault

3.10 Ceiling Design and Construction

The vault ceiling must be designed to support the hanging weight of all cable trays and conductors, including connection bus(es). The cable trays and connection buses must withstand the same seismic load considerations as the building. Conductor weights per lineal foot can be requested from the DPM. The ceiling must be 3-hour fire rated. Generally, customers use 12 inches minimum of rebar-reinforced 5000 psi concrete.

To support cable trays, conductor and ceiling mounted equipment, a threaded insert grid is installed in the vault ceiling before it is poured utilizing a Simpson Strong-Tie wood form “Blue Banger” insert (BBWF3762) grid. See [Appendix I, Simpson Strong-Tie “Blue Banger” Wood-Form Insert](#), for the manufacturer and ordering information. The grid must be installed 12 inches from the walls and 24-inch centers in the field.

Customers should reference [3.7, Lighting, Switches, and Outlets \(Boxes and Connecting Conduits\)](#), for additional items requiring installation before ceiling pour.



Figure 28. Installed Ceiling Grid

To meet OSHA and PGE safety requirements, OSHA-rated fall-restraint looped anchor inserts and swivel head D-rings must be placed where work more than 4 feet AFF will occur. See [Appendix L, Fall-Restraint Anchors](#), for product specific information.



Figure 29. Swivel D-rings

The minimum anchor inserts required are as follows:

- One on each side of and between connector bus(es) (30 inches from closest wall, 30 inches from edge of bus)
- One at primary conductor pulling eye location
- One at any radius in the primary cable tray
- One at the personnel access hatch opening (sub-grade installations only)
- Any additional rings deemed necessary by the FCC

3.11 Vault Detailing

When all the previous requirements are completed, the customer must complete the vault detailing as described below.

3.11.1 Paint

Apply two coats of white, mildew-resistant, non-toxic, waterproof paint to walls and ceiling before installing any surface-mounted equipment. PGE accepts LOXON XP and products of equal performance characteristics from other manufacturers.



Figure 30. White, Mildew-Resistant, Non-Toxic, Waterproof Paint

3.11.2 Cable Trays for Conductor Routing

The incoming primary conductor cable tray will route from the primary conductor conduit entrance point, above and parallel with the isolation Unistrut. The primary conductor cable tray will route at 9 feet AFF from the isolation location and pass over the primary bushings of all transformers in the vault. Primary cable trays are either 12, 18, 24, or 36 inches wide, with 6-inch siderails. The cable trays must be non-conductive, rated for 500 pounds of cable per foot, and have 9-inch rung spacing.

Secondary conductor cable tray(s) will route at 7 feet AFF from secondary connection points on each transformer to the connection bus that the transformer is serving. Secondary cable trays are 24 or 36 inches wide, with 6-inch siderails. The cable trays must be non-conductive, rated for 500 pounds of cable per foot, and have 9-inch rung spacing.

All cable trays must be supported from the ceiling with a 1/2-inch continuous threaded rod connected to Unistrut trapezes. The quantity of connections/trapezes is based on aggregate conductor weight and the manufacturer's recommendation. All cable tray installations must be accompanied by seismic reinforcing equal to or greater than the seismic load level of the building.

See [Appendix J, Husky and Atkore Product Sheets and Distributor Contact](#), for cable tray information.

IMPORTANT: Sub-grade vaults require galvanized or equivalent moisture-rated connecting hardware (Atkore Power-Strut Defender, galvanized, or equivalent for sub-grade vaults).



Figure 31. Primary Cable Tray



Figure 32. Secondary Cable Tray

3.11.3 Exhaust Fan

An exhaust fan allows PGE to clear air from an event by circulating fresh air into the vault through a vent in the exterior wall (at grade) or out the personnel or equipment access hatch(es) (sub-grade). The customer must design the room to include a 3-hour fire-rated vent, with fan activated damper, and must mount and connect a PGE supplied fan to the vent. Customers must supply a 30 A twist lock receptacle within 6 feet of the fan mounting location.

For at-grade vaults, discuss the location of the fan with PGE. PGE also requires a dedicated switch at the egress doors.

For sub-grade vaults, a PGE-supplied fan must be mounted outside the vault, with dedicated switches at the egress doors and personnel access hatch.

3.11.4 Climate Control

The Class A vault should contain thermostatic control and maintain 80 degrees.

1. Mount and connect cooling system control units (“heads”) to the exterior routed line sets and the compressor.
2. Mount and connect a controlling thermostat.
3. The compressor should be controlled from the building’s electrical room breaker panels.

3.11.5 Set Temp/Rate of Rise Heat Detectors Connect

PGE requires ceiling-mounted, set temperature (190–194°F), and rate of rise (15°/60 sec) heat detector(s) placed near the transformers and connector/collector bus locations. These must be connected to the building’s fire monitoring system. The number of transformers and room layout determines the total number and locations.

At a minimum, PGE will require one 2-stage rate-of-rise heat detector per transformer and connector bus (20-foot radius).

All connections to the fire monitoring system are “home runs” vs. “looped.” See [Appendix K, Heat Detectors Product Information](#) for product information.

3.11.6 Sump Pump / Evacuation Piping for Oil Containment

The means of oil containment must be capable of containing the total oil capacity of the largest transformer being placed in the room. Solicit the total oil capacity from your PGE team. Customers are responsible for procuring and installing the materials. The customer must supply a galvanized sump pit grate capable of supporting 300 pounds. PGE will provide a sump pump to be connected to a customer-installed 2-inch PVC evacuation pipe.

For sub-grade vaults, the 2-inch PVC evacuation pipe should be routed from the sump pit (24 inches AFF) to the ceiling just below the personnel access hatch (sub-grade) and turn 90 degrees toward the door opening along the equipment access doors (at grade). The pipe should be mounted 3 inches off the wall and terminate at the door(s) with an MPT, 2-inch male camlock fitting, and quick disconnect fitting.



Figure 33. Drain Line and Sump Grate



Figure 34. Drain Line at Door

3.12 No Backup Generator Present

If the building does not have backup generation, PGE will have additional requirements for powering components of the Class A vault. A manual disconnect and female plug pigtail may be required. Please contact PGE for specific requirements.

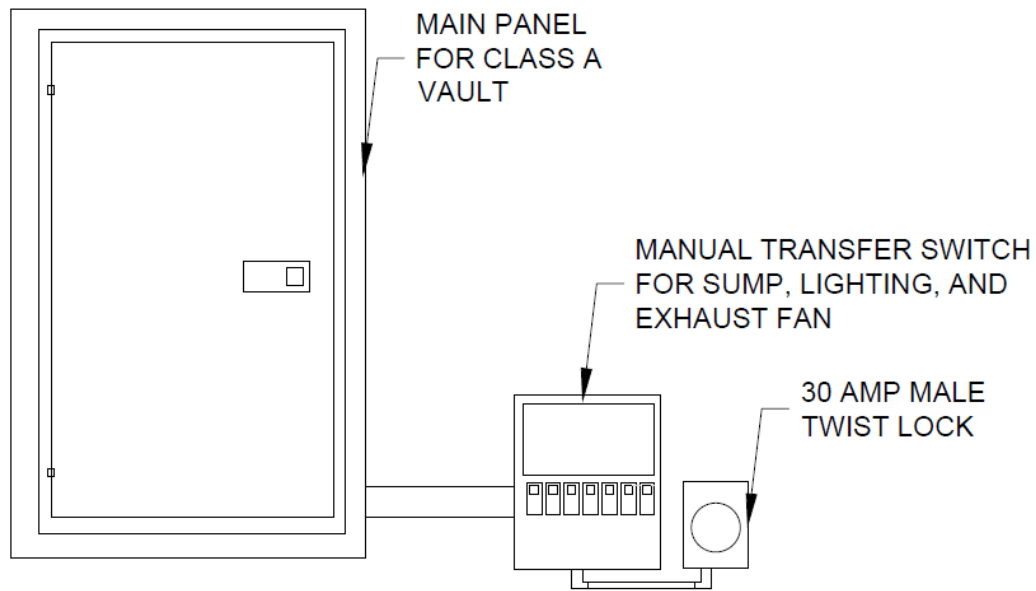

Figure 35. Class A Vault Electrical Panels Where No Generator Exists On-site (STD-D-6314)

3.13 Additional Items

For final vault approval, in addition to items listed previously, customers must complete the following:

- Mount all room and emergency egress lights.
- Install all plugs and labeled switches.
- Install heat detectors.
- Label all breakers in the breaker panel.
- Install egress doors and panic hardware; contact PGE locksmith for door keying once the wire and transformer date is established.
- Meet any additional equipment, locations, clearances, or requirements identified and requested during the design consideration process.

4 Construction Process

Class A Vault Design: Once the project team (usually the EE or installed electrical contractor) has created a Class A vault design and a vault construction drawing, with all required elements, PGE must review it. When all parties approve the design, PGE will include it in the project's permanent record, and construction can begin.

Construction Sequence and Inspections: The [Class A Vault Inspection Guide and Sequence](#) in [Appendix M](#) outlines the installation sequence for Class A vault elements and required inspections by PGE at each critical path junction. Additional progress inspections are available upon request, or may be required by, the assigned PGE Field Construction Coordinator.

Final Inspection: When the customer has passed the FCC's inspections, and the presiding jurisdiction has inspected and tagged the electrical switchboard in the electrical room, the customer's electrical contractor can contact PGE Service Coordination (503-323-6700) to request a final service inspection. Confirm all required labels listed below are present before the final inspection. Successful completion of the Service Inspection final will lead to PGE scheduling installation of the transformer, conductor, and meter.

Once transformers or conductors have been placed in the Class A vault, only PGE personnel will be allowed to enter the vault. Any additional work by contractors or general maintenance by the building's ownership will require a PGE Safety Standby crew to open the vault and monitor non-PGE personnel while their tasks are completed. Safety Standby crews are requested and scheduled through PGE Service Coordination (503-323-6700) and generally require 30 days prior notice.

4.1 Required Labels before Final Inspection

PGE requires the following labels in Class A vaults before the final inspection.

- Standard WARNING labels must be affixed to the outside of the vault exit doors. The label indicates that the vault is an energized location that can be accessed only by PGE personnel.
- A WARNING label (PGE part number 39273) must be affixed to the exterior of all inside doors. Refer to NEC 450.
- Each connection bus must have a phenolic label mounted on the wall 12–24 inches below the bus indicating the main distribution panel (MDP #), the ampacity of said MDP, and the voltage of the service.

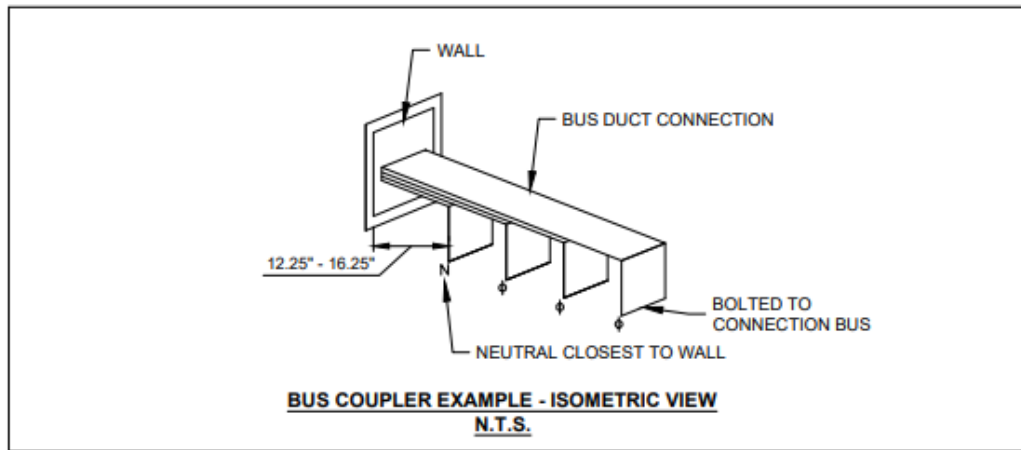
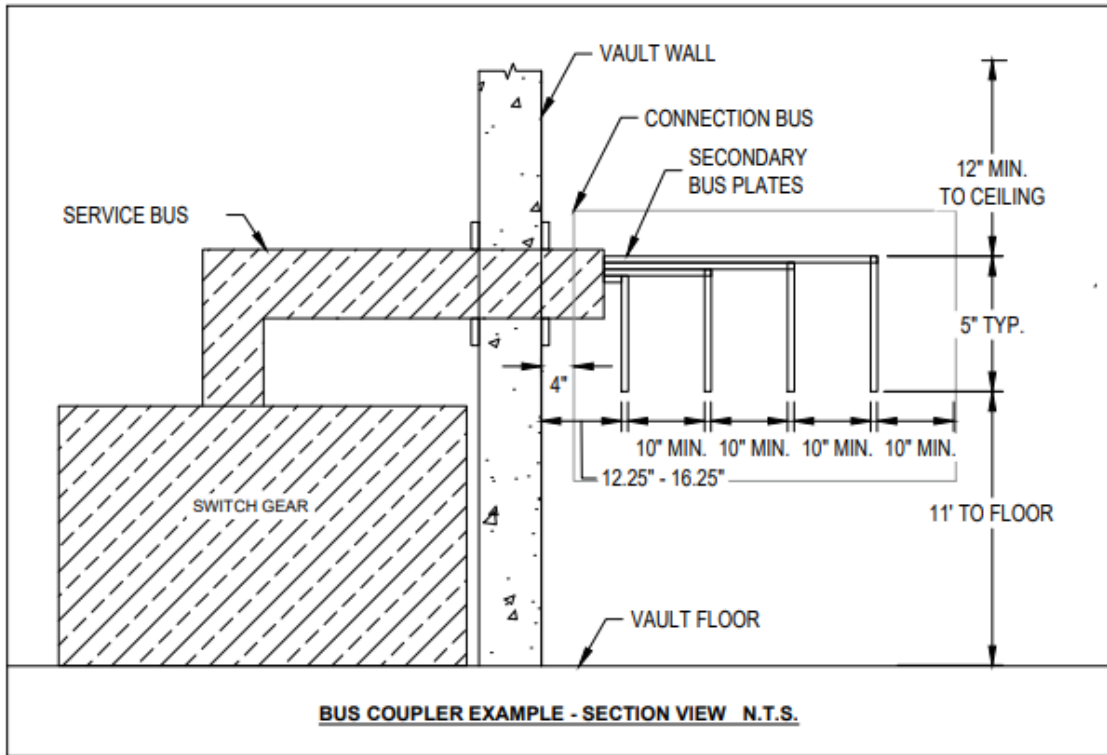

GENERAL NOTES:

1. COORDINATE CONNECTION BUS AND CONNECTION FLANGE MANUFACTURERS, SO BUS DUCT ALIGNS WITH THE FLANGE.
2. CUSTOMERS MUST SUBMIT SHOP DRAWINGS TO PGE REVIEW AND APPROVAL. PGE RECOMMENDS RECEIVING APPROVAL PRIOR TO PURCHASING EQUIPMENT.
3. THIS FIGURE IS A GENERAL REPRESENTATION OF THE REQUIREMENTS LISTED IN LD31007. THIS IS NOT A PLAN FOR CONSTRUCTION.
4. ALL BUS EQUIPMENT BUT BE SECURED TO VAULT WALL AND CEILING.

Public
Access Not Limited



**CLASS A VAULT
BUS COUPLER**

| | |
|--|---------------------|
| DOCUMENTS NONE CROSS REFERENCED: | DATE: 01/28/2023 |
| WARNING THIS DRAWING IS NOT VALID FOR CONSTRUCTION | DRAWN BY: |
| | SCALE: NOT TO SCALE |

| |
|--------------------------------|
| DEPARTMENT: STANDARDS |
| BUSINESS PARTNER: NONE |
| DRAWING NO.: STD-D-6340 |

STD-D-6340.DWG | 1/14/2023 12:14:38 PM | MARIE MENDEZ-ARNEZ

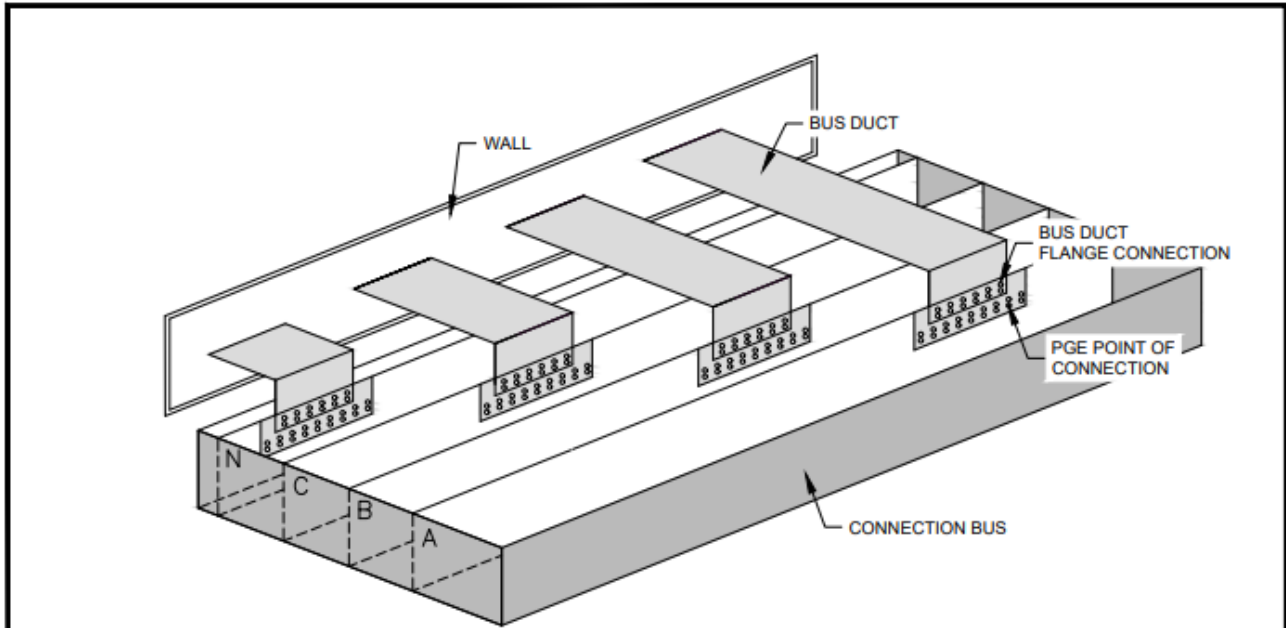

**BUS COUPLER EXAMPLE - ISOMETRIC VIEW
NON-ALIGNED FOR ILLUSTRATIVE PURPOSES**

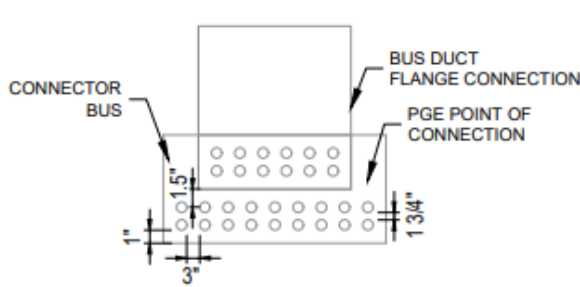

**DIMENSIONS OF SINGLE BUS DUCT
FLANGE CONNECTIONS**

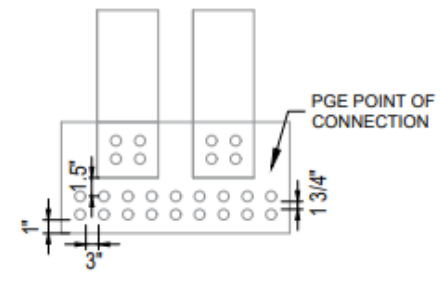

**DIMENSIONS FOR TWO BUS CUT
FLANGE CONNECTIONS**

GENERAL NOTES:

1. COORDINATE CONNECTION BUS AND CONNECTION FLANGE MANUFACTURERS, SO BUS DUCT ALIGNS WITH THE FLANGE.
2. CUSTOMERS MUST SUBMIT SHOP DRAWINGS TO PGE REVIEW AND APPROVAL. PGE RECOMMENDS RECEIVING APPROVAL PRIOR TO PURCHASING EQUIPMENT.
3. THIS FIGURE IS A GENERAL REPRESENTATION OF THE REQUIREMENTS LISTED IN LD31007. THIS IS NOT A PLAN FOR CONSTRUCTION.
4. ALL BUS EQUIPMENT MUST BE SECURED TO VAULT WALL AND CEILING.

Public
Access Not Limited



**CLASS A VAULT
BUS DUCT FLANGE CONNECTIONS**

| | |
|--|---------------------|
| DOCUMENTS NONE CROSS REFERENCED: | DATE: 10/30/23 |
| WARNING IF THIS BAR CODES NOT MEASURED BY TECHNICIAN TO SCALE | DRAWN BY: |
| | SCALE: NOT TO SCALE |

| |
|----------------------------------|
| DEPARTMENT: STANDARDS |
| BUSINESS PARTNER: NONE |
| DRAWING NO. STD-D-6342 |

PAGE SETUP: DWG TO PDF (PCS) HAS FULL BLEED (6.50X 11.0 INCHES)

STD-D-6342.DWG | 3/4/2026 12:19:03 PM | MARIE MENDEZ-NUNEZ

Appendix B. Personnel Hatch Specification (3-Foot x 3-Foot Doors)

The door size of the personnel hatch is 3 feet x 3 feet, while the doors plus the support ribbon are 5 feet x 5 feet. Refer to portlandgeneral.com/ESR for a complete list of PGE-approved manufacturers.

SHOP NOTES
1. ALL DRAIN PIPES CONNECTIONS TO BE AT SAME ELEVATION

APPROVED FOR FABRICATION

DATE 5/12/20 AN

BOM HAS BEEN UPDATED IN AX SALES

| # | QTY | MATERIAL | LENGTH | SHAPE |
|----|-----|----------|--------|-------|
| R1 | 16 | #4 BAR | 4'-9" | STR |

| PRODUCT | WEIGHT |
|---------|------------|
| TOP | 1,475 LBS. |

| # | QUANTITY | DESCRIPTION | ITEM # |
|---|----------|---|---------|
| 1 | 0.31 YDS | CONC. W/ #5 SCC STD | 5010030 |
| 1 | 0.51 CWT | REBAR #4 (688 LBS/FT) | 5510030 |
| 1 | 4 EA | 2-TON SPREAD (GALV) | 5100793 |
| 2 | 1 EA | EJH3636 PGE NON-SLIP DOOR W/ (STEEL RECESS) | 4940017 |
| 3 | 4 EA | DRAIN CHANNEL & RCP (36" x 36" OPENING) (NO ROSE) | 8200450 |
| 4 | 1 EA | DISCHARGE PIPE ASSEMBLY KIT - 1 1/4" RIGID | 5104050 |

Oldcastle Infrastructure
A CRH COMPANY
PO BOX 333 WA SPOKANE, OR 97701 PHONE: 509.882.2844 FAX: 509.882.9897

THIS DOCUMENT IS THE PROPERTY OF OLDCASTLE INFRASTRUCTURE, A CRH COMPANY. IT IS CONFIDENTIAL, SUBMITTED FOR REFERENCE PURPOSES ONLY, AND SHALL NOT BE USED IN ANY WAY WITHOUT THE EXPRESS WRITTEN PERMISSION OF OLDCASTLE INFRASTRUCTURE. ALL RIGHTS RESERVED.

5' x 5' x 8" SLAB W/ EJ CH3636 DOOR
PRODUCTION & REINFORCING
PGE - MARQUAM - OHSU 1022 & 818 VAULTS
PORTLAND, OR

CUSTOMER: PGE

| | | | | |
|-----------------------|----------------|-----------------|---------|----------|
| DATE | DESIGN | DESIGN/ENGINEER | CHECKED | DRAWN BY |
| 3/27/19 | TC | AN | AN | 156420 |
| | PROJECT NUMBER | REVISION | | SHEET |
| 6060SLB-EJ-CH3636-PGE | | | | 1 OF 1 |

PLAN VIEW - REINFORCING
SCALE: 7/16" = 1'-0"

VIEW A
SCALE: 7/16" = 1'-0"

VIEW B
SCALE: 7/16" = 1'-0"

PLAN VIEW - PRODUCTION
SCALE: 7/16" = 1'-0"

VIEW A
SCALE: 7/16" = 1'-0"

VIEW B
SCALE: 7/16" = 1'-0"

Appendix C. Equipment Access Hatch (6-Foot x 8-Foot Doors)

The door size of the personnel hatch is 6 feet x 8 feet, while the doors plus the support ribbon are 8 feet x 10 feet. Refer to portlandgeneral.com/ESR for a complete list of PGE-approved manufacturers.

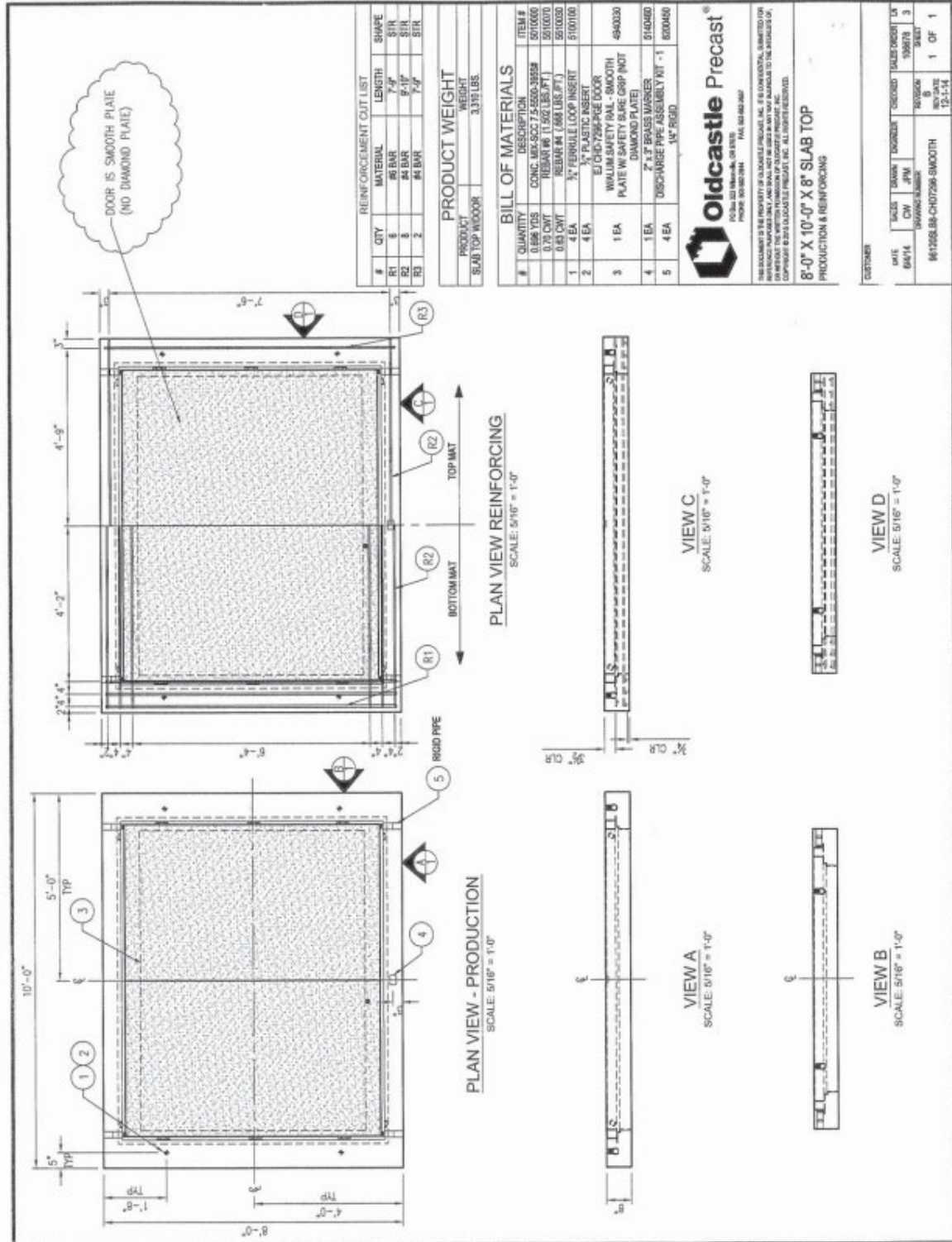

Appendix D. Ground Insert Specification

KBR machined bronze ground inserts provide a threaded point of attachment of ground wires. Inserts can be flush mounted in manholes or vaults. To ensure a positive connection, the carbon steel rod is threaded into the bronze inserts, not brazed. The steel rod is then attached to the rebar or wire mesh cage.

KBR Telephone: (503) 757-1053

E-mail: KBRindustries@gmail.com

Specification for 26-inch steel rod grounding hub manufacturer by KBR Industries, LLC.

KBR INDUSTRIES, LLC

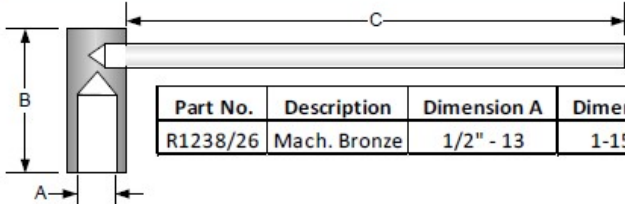

| Part No. | Description | Dimension A | Dimension B | Dimension C |
|----------|--------------|-------------|-------------|----------------------|
| R1238/26 | Mach. Bronze | 1/2" - 13 | 1-15/16" | 3/8" x 26" steel rod |

Appendix E. Spread Anchor Specification

RL-23 SPREAD ANCHOR

2-Ton, 4-Ton, 8-Ton and 22-Ton

The RL-23 Spread Anchor is designed with a spread-foot that produces exceptional pull out capacity. This versatile anchor can be used in the face, back or edge of panels for back stripping and rotation from horizontal to vertical. This anchor can be pulled in any direction as long as minimum edge distance is maintained. However spalling may occur when pulling in shear perpendicular to the long side of the void. A minimum 3/4" concrete cover below the anchor is recommended. The Spread Anchor is available in the sizes shown in the table and in plain or hot dip galvanize finish.

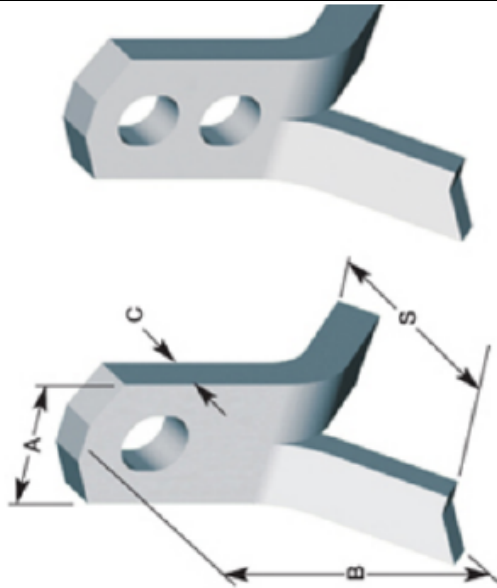

NOTE: The spread anchor has allowable face shear loads that are equal to or greater than the face tension loads for anchors located in a panel or concrete unit at a distance of 3B+A from the edge.

| RL-23 SPREAD ANCHOR DATA | | | | | | | | | | |
|--------------------------|-------------|-------------|-----------------|--------|---------|-------|--------|--|--|------------------------|
| Ring Clutch System | Clutch I.D. | Item Number | Additional Hole | A | B | C | S | Allowable Unreinforced Tension Load 4:1 SF (lbs) | Ultimate Mechanical Load Tension (lbs) | Weight Per Piece (lbs) |
| 2T/2.5T | 2.5T | 79050 | No | 1 1/4" | 4 3/4" | 3/16" | 2 3/4" | 2,000 | 8,000 | 0.32 |
| 2T/2.5T | 2.5T | 79110 | No | 1 1/4" | 4" | 3/8" | 2 3/4" | 2,530 | 16,000 | 0.49 |
| 2T/2.5T | 2.5T | 79059 | No | 1 1/4" | 5 1/2" | 3/8" | 2 3/4" | 4,000 | 16,000 | 0.73 |
| 4T/5T | 5T | 79113 | No | 1 1/2" | 4" | 1/2" | 3 3/8" | 2,670 | 24,000 | 0.96 |
| 4T/5T | 5T | 79114 | No | 1 1/2" | 4 3/4" | 1/2" | 3 3/8" | 3,590 | 24,000 | 1.12 |
| 4T/5T | 5T | 79115 | No | 1 1/2" | 6 3/4" | 1/2" | 3 3/8" | 6,720 | 32,000 | 1.40 |
| 4T/5T | 5T | 79116 | No | 1 1/2" | 6 1/4" | 5/8" | 3 3/8" | 5,850 | 32,000 | 1.61 |
| 4T/5T | 5T | 79117 | Yes | 1 1/2" | 9 1/2" | 5/8" | 3 3/8" | 8,000 | 32,000 | 2.48 |
| 8T/10T | 10T | 79319 | Yes | 2 1/2" | 11" | 5/8" | 5 1/4" | 12,000 | 48,000 | 4.48 |
| 8T/10T | 10T | 79119 | Yes | 2 1/2" | 11" | 3/4" | 5 1/4" | 16,000 | 64,000 | 5.37 |
| 22T/26T | 26T | 79172 | Yes | 3 1/8" | 15" | 3/4" | 6 1/4" | 32,800 | 136,000 | 9.59 |
| 22T/26T | 26T | 79174 | Yes | 3 1/8" | 18 7/8" | 1" | 6 1/4" | 44,000 | 176,000 | 16.07 |

Cable install

Transformer install

Appendix F. "Bug-Eye" Emergency Egress Lights Specifications



FEATURES & SPECIFICATIONS

INTENDED USE — Provides a minimum of 90 minutes illumination for the rated wattage upon loss of AC power to meet and exceed code required emergency lighting. Ideal for applications requiring attractive LED unit equipment with quick installation and unparalleled performance for mounting heights from 7.5' to 30'. **Certain airborne contaminants can diminish the integrity of acrylic and/or polycarbonate.** [Click here for Acrylic-Polycarbonate Compatibility table for suitable uses.](#)

CONSTRUCTION — The housing is a standard white (black optional) thermoplastic with a compact and low-profile contemporary design. It is 5VA flame rated, impact-resistant, scratch-resistant and corrosion proof. The UV-stable resin resists discoloration from natural and man-made light sources. There is a low-profile, integrated and back-lit test switch with an easily visible multi-color LED status indicator. The back-plate contains a universal J-box mounting pattern to facilitate ease of installation on a wide variety of j-boxes and the front housing allows tool-less access for ease of maintenance.

The lamp heads have a unique track-and-swivel arrangement permitting full range of direction of optical aiming.

OPTICS — The ELM4L features two high-performance LEDs rated at 3.3 watts per lamp head and delivers a total of 640 lumens in a spot pattern (SP640L).

The ELM6L features three high-performance LEDs rated at 5.3 watts per lamp head and delivers a total of 1,100 lumens in a spot pattern (SP1100L).

The typical life of an LED is 10 years. The LED light sources typically never need to be replaced under normal conditions for normal off applications.

CCT: 5000K

ELECTRICAL — Orderable in multiple voltages (see ordering tree for specific voltages.)

Current-limiting charger maximizes battery life and minimizes energy consumption to provide low operating costs. Small battery chargers Certified in the CA Title 20 Appliance Efficiency Database.

Short-circuit protection — current-limiting charger circuitry protects printed circuit board from shorts.

Regulated charge voltage maintains a stable charge voltage over a wide range of line voltages.

Prevents over/undercharging that shortens battery life and reduces capacity. Filtered charger input minimizes charge voltage ripple and extends battery life.

BATTERY: Sealed, maintenance-free nickel-cadmium (ELM4L only) or Lithium Iron Phosphate battery. Optional High-Output (HO option) and Extra High Output (EHO option), LTP battery type only, provides a wide variety of remote capacities and/or extended run-times.

SELF-DIAGNOSTICS and REMOTE TEST (SDRT option):

Automatic 24-hour recharge after a 90-minute discharge.

Advanced electrical design provides constant light output throughout the entire discharge period.

Brownout protection is automatically switched to emergency mode when supply voltage drops below approximately 80 percent nominal of 120, 220, 277 or 347. Other input voltages may vary.

AC/LVD reset allows battery connection before AC power is applied and prevents battery damage from deep discharge.

Self-Diagnostics: Continuously monitors AC functionality. Test switch and remote tester (RTKIT accessory) provide manual activation of 30-second diagnostic testing for on-demand visual inspection. Standard derangement monitoring will indicate disconnected battery, charger failure and displays green flashing indicator light while in emergency mode. Single multi-chromatic LED indicator to display two-state charging, test activation and three-state self-diagnostics.

Self-diagnostic testing: Five minutes every 30 days and 90 minutes annually. Diagnostic evaluation of lamps, AC to DC transfer, battery charging and condition of microprocessor. Automatic test is easily postponed for eight hours by activating manual test switch or use of remote tester (RTKIT accessory).

INSTALLATION — Wall and ceiling mount standard. Blind-mate connector ensures easy installation and safe maintenance. 7/8" entrance provision at top of unit for standard 1/2" conduit entry. Tool-less removal of front cover from back-plate for ease of installation and maintenance.

LISTINGS — UL damp location listed standard and wet location listed when used with the WPVS accessory, all at 50-104°F (10-40°C). Meets or exceeds all applicable requirements for UL 924, NFPA 101 (current Life Safety code), NFPA 70 (NEC), NOM (Norma Oficial Mexicana), California Energy Commission Title 20 section 1605.3 (W)(4), FCC Title 47, Part 15, Subpart B and OSHA. List and labeled to comply with Canadian Standards C22.2 No. 141-10.

WARRANTY — 5-year limited warranty. Complete warranty terms located at:

www.acuitybrands.com/support/customer-support/terms-and-conditions

NOTE: Actual performance may differ as a result of end-user environment and application.

All values are design or typical values, measured under laboratory conditions at 25 °C.

Specifications subject to change without notice.

† Small Battery Chargers Certified in the CA Title 20 Appliance Efficiency Database.



| |
|----------------|
| Catalog Number |
| Notes |
| Type |



Contemporary Commercial LED Emergency Light



ELM4L
640 Lumens

ELM6L
1100 Lumens

LITHIUM IRON PHOSPHATE
NICKEL CADMIUM



MOUNTING

All dimensions are inches (centimeters) unless otherwise indicated.

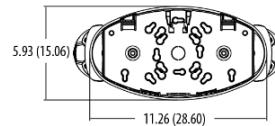
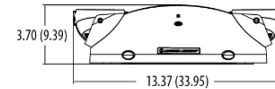
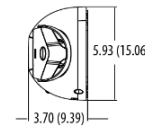
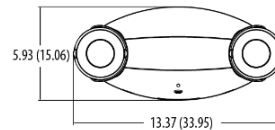

Specifications

- Length: 13 3/8 (33.95)
- Depth: 3 45/64 (9.39)
- Height: 5 15/16 (15.06)
- Weight: ELM4L 3 lb (1.4kg)
- Weight: ELM6L 3 lb (1.4kg)
- Weight: ELM6L HO 3.5 lbs (1.59 kg)
- Weight: ELM6L EHO 3.75 lbs (1.7 kg)

EMERGENCY

ELM4L_ELM6L
Pg. 1 of 5

Appendix G. PGE-Supplied Fan Specifications



SPECIFICATIONS

Product Description: **VENTILATION BLOWER, HIGH OUTPUT**
 Part Number: **9516**
 Style: **AXIAL FAN 16" (40.6 cm)**

GENERAL DESCRIPTION:

Our 16" (40.6 cm) High Output blower offers a high-powered motor for applications requiring a maximum amount of output. Certified to CSA Standard C22.2 No.113.



CONSTRUCTION:

- Complete unit epoxy powder coated in "safety orange"
- Interchangeable flange for intake/exhaust side mounting
- 18-gauge cold rolled steel housing
- Bolted motor mount construction
- Integrated carrying handles
- Steel/chrome plated grill
- Equipped with four rubber feet

MOTOR:

HP: 2 HP
 Certifications: UL Recognized, CSA Certified
 Voltage/Hz 115/230V AC, 60 Hz, Single Phase
 RPM: 3450
 Current Draw: 21/10.5A
 Cord: 25' (7.62 m) 12/3 AWG, SJOOW-A Neoprene 300V medium duty
 Plug: NEMA 5-30P or NEMA 6-30P (Twist Lock type)

FAN:

- Glass reinforced polypropylene (PPG) three blade fan with aluminum hub
- Moving fan mounted 1 5/8" (4.12 cm) from grill for safety, grill gap-5-16" (0.79 cm)

DUCTING: (Optional)

- Retractable, non-collapsible design
- Single-ply, PVC coated, vinyl and polyester materials, temperature resistant up to 180° F (82.22° C)
- Yellow color with black weather-strip and integrated nylon straps
- Class 1 hard drawn spring steel wire helix that meets ASTM 227 specs

BLOWER DIMENSIONS:

| Length | Width | Height | Weight |
|---------------|---------------|---------------|-------------------|
| 18" (45.7 cm) | 18" (45.7 cm) | 19" (48.2 cm) | 74 lbs. (33.4 kg) |

FLOW RATES: (CFM calculated using 15' (4.57 m) of 16" (40.6 cm) ducting)

| Free Air | One 90° Bend | Two 90° Bends |
|-----------------------------------|----------------------------------|---------------------------------------|
| 5500 (9311.55 m ³ /hr) | 4950 (8410.1 m ³ /hr) | 4400 CFM (7475.64 m ³ /hr) |

1380 Shiloh Church Road Piedmont, SC 29673 864-846-8740 800-822-3530 FAX: 800-362-7231 www.allegrosafety.com

Rev I 10-29-19

Appendix H. PGE-Supplied Fan Bracket Mounting Hardware

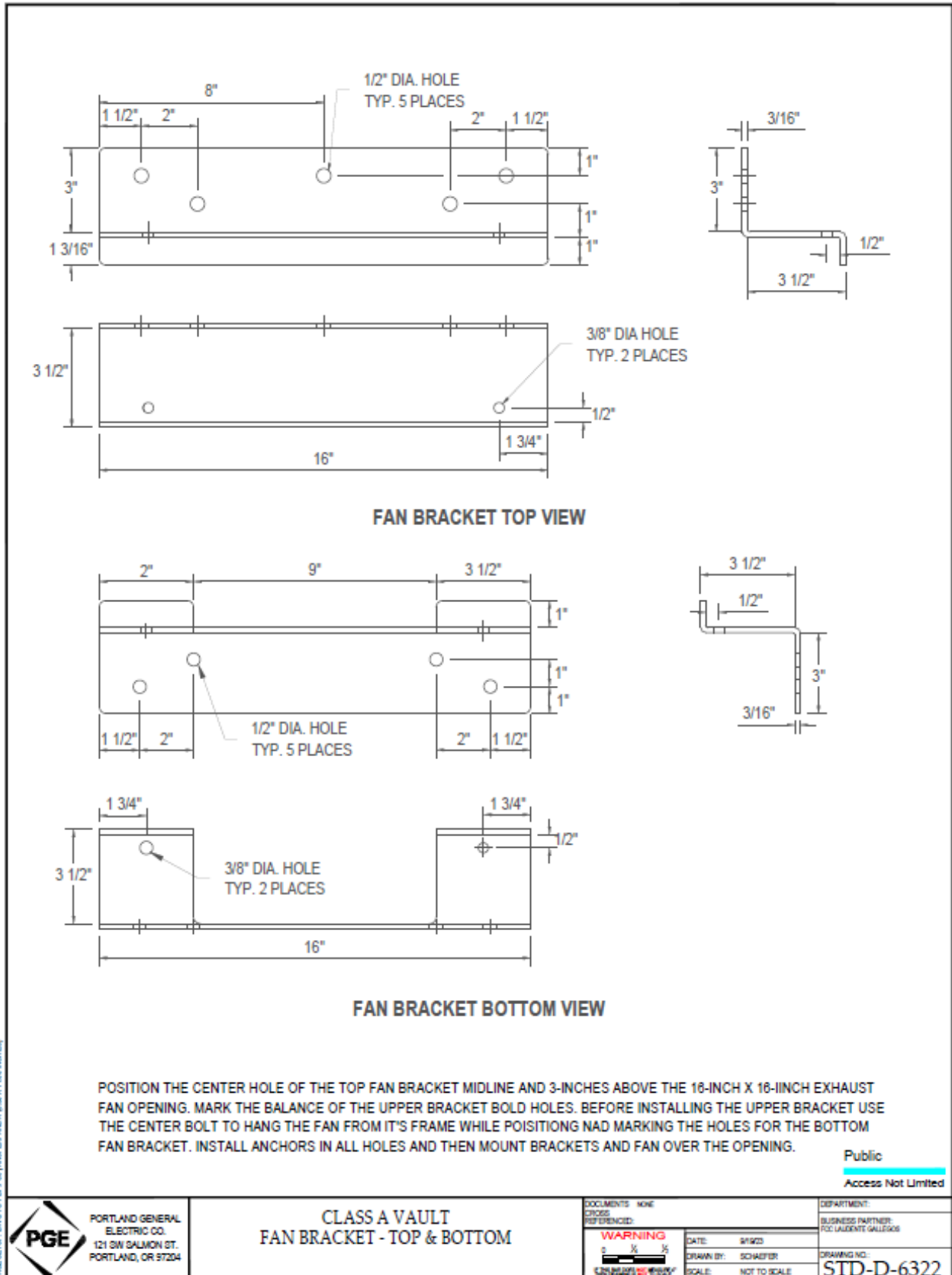

Appendix I. Simpson Strong-Tie "Blue Banger" Wood-Form Insert

Blue Banger Hanger®

Wood-Form Insert



Features

- Code-listed under the 2012 IBC/IRC in accordance with AC408 for cracked and uncracked concrete applications, per ICC-ES ESR-3707
- Blue plastic ring acts as an insert locator when forms are removed
- Plastic ring creates a countersunk recess to keep internal threads clean from concrete residue
- Nails snap off with the swipe of a hammer after the forms are removed
- Multi-thread design allows insert to accept multiple rod diameters



Installation

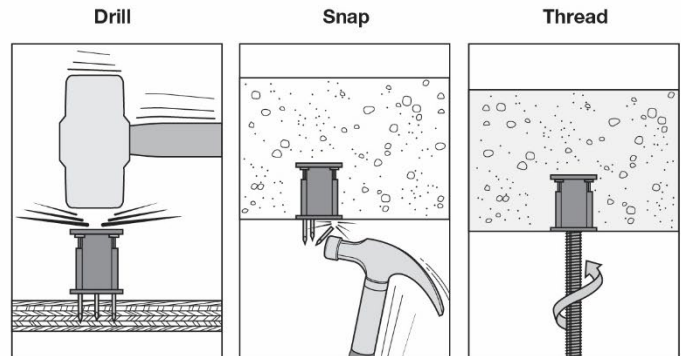

Drill
Strike the top of the hanger and drive the 3 mounting nails into the forming material until the bottom of the hanger is flush with the bottom of the plywood. The hanger should be sitting 90° from the forming material.

Snap
Once concrete is hardened and forms are stripped, strike the mounting nails to break them off.

Thread
Insert the rod into the sleeve and thread it into the hanger.

Product Data

| Hanger Type | For Rod Diameter (in) | Model Number | Carton Qty. |
|------------------|-----------------------|--------------|-------------|
| Wood-Form Insert | 1/4, 3/8, 1/2 | BBWF2550 | 200 |
| | 3/8, 1/2, 5/8 | BBWF3762 | 150 |
| | 5/8, 3/4 | BBWF6275 | 150 |

CODES: ICC-ES ESR-3707; Factory Mutual 3024378 (see pipe size limit tables); Underwriters Laboratories File Ex3605 (see pipe size limit tables)



MATERIAL: Carbon steel
FINISH: Yellow zinc dichromate coating

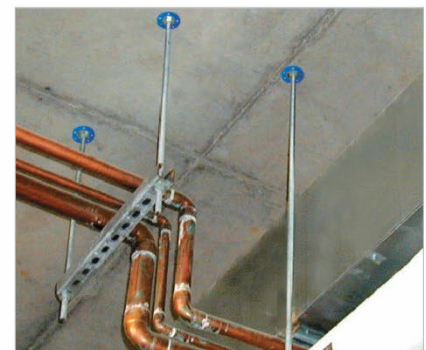



Wood-Form Insert: Tension Loads in Normal-Weight or Sand-Lightweight Concrete

| Model No. | Threaded Rod Dia. in. | Embed. Depth in. (mm) | Min. Edge Dist. in. (mm) | Min. Spacing in. (mm) | Tension Load Based on Concrete Strength (Normal Weight) | | Tension Load Based on Rod Strength (Normal Weight) | Tension Load Based on Concrete Strength (Sand-Lightweight) | | Tension Load Based on Rod Strength (Sand-Lightweight) |
|-----------|-----------------------|-----------------------|--------------------------|-----------------------|---|---------------------|--|--|---------------------|---|
| | | | | | f'c ≥ 3,000 psi (20.7 Mpa) | | F1554 Grade 36 | f'c ≥ 3,000 psi (20.7 Mpa) | | F1554 Grade 36 |
| | | | | | Ultimate lbs. (kN) | Allowable lbs. (kN) | Allowable lbs. (kN) | Ultimate lbs. (kN) | Allowable lbs. (kN) | Allowable lbs. (kN) |
| BBWF2550 | ¼ | 2 (51) | 7 (178) | 8 (203) | 6,820 (30.3) | 1,705 (7.6) | 940 (4.2) | 4,280 (19.0) | 1,070 (4.8) | 940 (4.2) |
| | ⅜ | | | | | | 2,105 (9.4) | | | 2,105 (9.4) |
| | ½ | | | | | | 3,750 (16.7) | | | 3,750 (16.7) |
| BBWF3762 | ⅜ | 2 (51) | 7 (178) | 8 (203) | 7,360 (32.7) | 1,840 (8.2) | 2,105 (9.4) | — | — | — |
| | ½ | | | | | | 3,750 (16.7) | | | — |
| | ¾ | | | | | | 5,875 (26.1) | | | — |
| BBWF6275 | ⅝ | 2 (51) | 7 (178) | 8 (203) | 7,420 (33.0) | 1,855 (8.3) | 5,875 (26.1) | 4,400 (19.6) | 1,100 (4.9) | 5,875 (26.1) |
| | ¾ | | | | | | 8,460 (37.6) | | | 8,460 (37.6) |

Wood-Form Insert: Shear Loads in Normal-Weight or Sand-Lightweight Concrete

| Model No. | Threaded Rod Dia. in. | Embed. Depth in. (mm) | Min. Edge Dist. in. (mm) | Min. Spacing in. (mm) | Shear Load Based on Concrete Strength (Normal Weight) | | Shear Load Based on Rod Strength (Normal Weight) | Shear Load Based on Concrete Strength (Sand-Lightweight) | | Tension Load Based on Rod Strength (Sand-Lightweight) |
|-----------|-----------------------|-----------------------|--------------------------|-----------------------|---|---------------------|--|--|---------------------|---|
| | | | | | f'c ≥ 3,000 psi (20.7 Mpa) | | F1554 Grade 36 | f'c ≥ 3,000 psi (20.7 Mpa) | | F1554 Grade 36 |
| | | | | | Ultimate lbs. (kN) | Allowable lbs. (kN) | Allowable lbs. (kN) | Ultimate lbs. (kN) | Allowable lbs. (kN) | Allowable lbs. (kN) |
| BBWF2550 | ½ | 2 (51) | 7 (178) | 8 (203) | 8,750 (38.9) | 2,185 (9.7) | 1,930 (8.6) | 8,600 (38.2) | 2,150 (9.6) | 1,930 (8.6) |
| BBWF3762 | ⅝ | 2 (51) | 7 (178) | 8 (203) | 10,700 (47.6) | 2,675 (11.9) | 3,025 (13.4) | — | — | — |
| BBWF6275 | ¾ | 2 (51) | 7 (178) | 8 (203) | 10,460 (46.5) | 2,615 (11.6) | 4,360 (19.4) | 9,260 (41.2) | 2,315 (38.9) | 4,360 (19.4) |

1. Allowable load must be the lesser of the concrete or steel strength.
2. The allowable loads based on concrete strength are based on a factor of safety of 4.0.
3. Allowable loads may not be increased for short-term loading due to wind or seismic forces.
4. Mechanical and plumbing design codes may prescribe lower allowable loads. Verify with local codes.
5. Minimum concrete slab thickness = 2x embedment depth.

Metal-Deck Insert: Tension Loads in Normal-Weight or Sand-Lightweight Concrete over Metal Deck

| Model No. | Drill Bit Dia. in. | Threaded Rod Dia. in. | Embed. Depth in. (mm) | Min. Edge Dist. in. (mm) | Min. Spacing in. (mm) | Tension Load Based on Concrete Strength (Install in High Flute) | | Tension Load Based on Concrete Strength (Install in Low Flute) | | Tension Load Based on Rod Strength |
|-----------|--------------------|-----------------------|-----------------------|--------------------------|-----------------------|---|---------------------|--|---------------------|------------------------------------|
| | | | | | | f'c ≥ 3,000 psi (20.7 Mpa) | | f'c ≥ 3,000 psi (20.7 Mpa) | | F1554 Grade 36 |
| | | | | | | Ultimate lbs. (kN) | Allowable lbs. (kN) | Ultimate lbs. (kN) | Allowable lbs. (kN) | Allowable lbs. (kN) |
| BBMD2550 | 1 3/16 - 7/8 | ¼ | 2 (51) | 7 ½ (191) | 8 (203) | 9,320 (41.5) | 2,330 (10.4) | 3,210 (14.3) | 800 (3.6) | 940 (4.2) |
| | | ⅜ | | | | | | | | 2,105 (9.4) |
| | | ½ | | | | | | | | 3,750 (16.7) |
| BBMD3762 | 1 ½ - 1 3/8 | ⅜ | 2 (51) | 7 ¼ (191) | 8 (203) | 10,540 (46.9) | 2,635 (11.7) | 3,440 (15.3) | 860 (3.8) | 2,105 (9.4) |
| | | ½ | | | | | | | | 3,750 (16.7) |
| | | ⅝ | | | | | | | | 5,875 (26.1) |
| BBMD6275 | 1 3/16 - 1 3/8 | ⅝ | 2 (51) | 7 ½ (191) | 8 (203) | 12,360 (55.0) | 3,090 (13.7) | 3,445 (15.3) | 860 (3.8) | 5,875 (26.1) |
| | | ¾ | | | | | | | | 8,460 (37.6) |

Appendix J. Husky and Atkore Product Sheets and Distributor Contact

Cable trays must be purchased from vendors collaborating with a local supplier. One or more suppliers may be available. Two vendors that have been previously selected by PGE customers include:

IMPORTANT: Sub-grade vaults require galvanized or equivalent moisture-rated connecting hardware (Atkore Power-Strut Defender, galvanized, or equivalent for sub-grade vaults).

Atkore

Items: Atkore sells cable trays, hardware (Unistrut), and seismic supports.

Bob Bullock Outside Sales / Quotations
(503) 577-1659 bob@pacwestern.com

Husky

Items: Husky sells cable trays.

Matt Kirtland
(864) 234-4804

Appendix K. Heat Detectors Product Information



5600 Series Mechanical Heat Detectors

System Sensor's 5600 series mechanical heat detectors offer a low-cost means for property protection against fire, and for non-life-safety installations where smoke detectors are inappropriate.



Features

- Multiple configurations for installations:
 - Single- and dual-circuit models
 - Fixed temp and combination fixed- temp/rate-of-rise 135°F or 194°F ratings.
- Plain housing for residential installations (Model 5601P)
- Easy-to-use terminal screws
- A broad range of back box mounting options:
 - Single gang
 - 3.5" and 4" Octagonal
 - 4" square with square to round plaster ring
- Reversible mounting bracket

Multiple configurations. The 5600 series offers a full-line of configurations to accommodate a broad range of applications. Both single- and dual-circuit models are available for low- and high-temperature ratings with either fixed temperature or combination fixed temperature/rate-of-rise (ROR) activation. The ROR element of the fixed/ROR models is restorable to accommodate field-testing.

Installation flexibility. To satisfy a variety of installation needs, the 5600 series easily mounts to single-gang and octagonal back boxes. And these models accommodate four-square back boxes, when used with a square to round plaster ring. The reversible mounting bracket permits both flush- and surface-mount back box installations.

Visual identification. The 5600 series provides clear markings on the exterior of the unit to ensure that the proper detector is being used. Alphanumeric characters identify the activation method, as well as the temperature rating, in Fahrenheit and Celsius degrees. Fixed temperature models are identified FX, while combination fixed/rate-of-rise units are marked FX/ROR. The 5600 series also provides a post-activation indicator in the form of a collector. When the detector is activated, the collector drops from the unit, making it easy to identify the unit in alarm.

Agency Listings



Specifications

Architectural/Engineering Specifications

Mechanical heat detector shall be a System Sensor 5600 series model number _____, listed to Underwriters Laboratories UL 521 for Heat Detectors for Fire Protective Signaling Systems. The detector shall be either a single-circuit or a dual-circuit type, normally open. The detector shall be rated for activation at either 135°F (57°C) or 194°F (90°C), and shall activate by means of a fixed temperature thermal sensor, or a combination fixed temperature/rate-of-rise thermal sensor. The rate-of-rise element shall be activated by a rapid rise in temperature, approximately 15°F (8.3°C) per minute. The detector shall include a reversible mounting bracket for mounting to 3½-inch and 4-inch octagonal, single gang, and 4-inch square back boxes with a square to round plaster ring. Wiring connections shall be made by means of SEMS screws that shall accommodate 14–22AWG wire. The detector shall contain alphanumeric markings on the exterior of the housing to identify its temperature rating and activation method. The rate-of-rise element of combination fixed temperature/rate-of-rise models shall be restorable, to allow for field-testing. The detectors shall include an external collector that shall drop upon activation to identify the unit in alarm.

Physical/Operating Specifications

| | |
|---|---|
| Maximum Installation Temperature | 5601P, 5603, 5621, and 5623: 100°F (38°C) 5602, 5604, 5622, and 5624: 150°F (65.6°C) |
| Operating Humidity Range | 5 to 95% RH non-condensing |
| Dimensions with mounting bracket | Diameter: 4.57 inches (11.6cm) Height: 1.69 inches (4.3cm) |
| Alarm Temperature | 5601P, 5603, 5621, and 5623: 135°F (57°C) 5602, 5604, 5622, and 5624: 194°F (90°C) |
| Weight | 6 oz. (170 grams) |
| Rate-of-Rise Threshold | 15°F (8.3°C) rise per minute (models 5601P, 5602, 5621, and 5622 only) |
| Mounting | 3½-inch octagonal back box 4-inch octagonal back box Single gang back box 4-inch square back box with a square to round plaster ring |

Electrical Specifications

| | |
|--|---|
| Operating Voltage / Contact Ratings | 6–125VAC / 3A 6–28VDC / 1A 125VDC / 0.3A 250VDC / 0.1A |
| Input Terminals | 14–22 AWG |

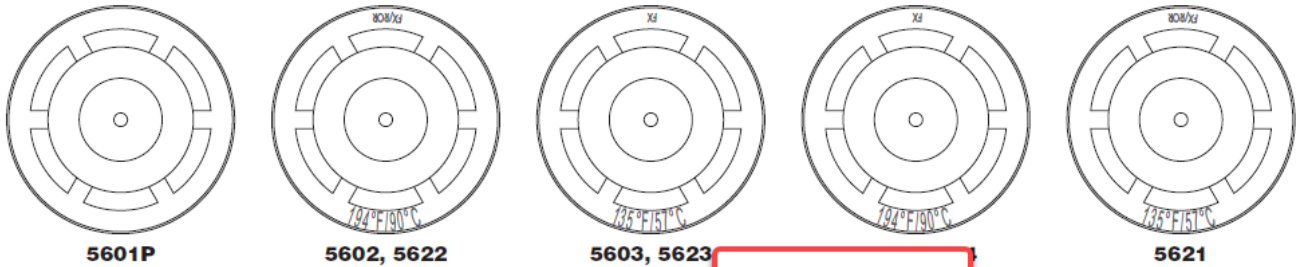

Model Meeting PGE Requirements

Ordering Information

| Model | Circuit | Identification Method on Exterior | Temperature Rating | Activation | UL Protected Spacing – 10 Foot Ceiling* |
|-------|---------|-----------------------------------|--------------------|----------------------------------|---|
| 5601P | Single | None | 135°F (57°C) | Fixed Temperature / Rate-of-Rise | 50 feet x 50 feet (15.24m x 15.2m) |
| 5602 | Single | Lettering | 194°F (90°C) | Fixed Temperature / Rate-of-Rise | 50 feet x 50 feet (15.24m x 15.2m) |
| 5603 | Single | Lettering | 135°F (57°C) | Fixed Temperature | 25 feet x 25 feet (7.62m x 7.62m) |
| 5604 | Single | Lettering | 194°F (90°C) | Fixed Temperature | 25 feet x 25 feet (7.62m x 7.62m) |
| 5621 | Dual | Lettering | 135°F (57°C) | Fixed Temperature / Rate-of-Rise | 50 feet x 50 feet (15.24m x 15.2m) |
| 5622 | Dual | Lettering | 194°F (90°C) | Fixed Temperature / Rate-of-Rise | 50 feet x 50 feet (15.24m x 15.2m) |
| 5623 | Dual | Lettering | 135°F (57°C) | Fixed Temperature | 25 feet x 25 feet (7.62m x 7.62m) |
| 5624 | Dual | Lettering | 194°F (90°C) | Fixed Temperature | 25 feet x 25 feet (7.62m x 7.62m) |

*NOTE: Refer to NFPA72 guidelines for spacing reductions when ceiling heights exceed 10 feet.



3825 Ohio Avenue • St. Charles, IL 60174
Phone: 800-SENSOR2 • Fax: 630-377-6495
www.systemsensor.com

©2013 System Sensor.
Product specifications subject to change without notice. Visit systemsensor.com for current product information, including the latest version of this data sheet.
SPDS30001 • 7/13

Appendix M. Class A Vault Inspection Guide and Sequence

| Class A Vault Inspection Guide and Sequence | |
|---|----------------------------------|
| M#: _____ | Vault address: _____ |
| DPM: _____ | CPM: _____ |
| Electrical Contractor: _____ | Electrical Foreman: _____ |
| GC Contact: _____ | |
| <input type="checkbox"/> Development/Approval of vault design and received by PGE | |
| Structural Ground(s) | |
| Method 1 and 2: 250 MCM Bare-Stranded Copper Connections or Slab on Grade | |
| <input type="checkbox"/> ___ Plate extensions (continuous welds on plate components, plate mounts; grinding on soldier piles) | |
| <input type="checkbox"/> ___ Cadweld attachments of 250 MCM to plates (number of welds, separation (24")) | |
| Method 3: Drilled Piers | |
| <input type="checkbox"/> ___ number of ground rods; (2 welds per rod; spacing of rods, spacing of welds; welded to 250 MCM loop) | |
| <input type="checkbox"/> ___ 250 MCM tails for connection to equipotential loop in walls | |
| INSPECTION #1 should be scheduled with the project's FCC when the above is complete. | |
| VAULT FLOOR | |
| <input type="checkbox"/> Burke clutch receivers, a.k.a. "spread anchors" (RL-23/#79319/12,000#/5-1/4" W x 11" H) | |
| <input type="checkbox"/> Locations/orientation (stem/cup in-line with pulling direction)/secured to rebar | |
| <input type="checkbox"/> Sump pit location/size (min. 15" x 15" x 12") | |
| <input type="checkbox"/> 1/16" per foot floor slope to the sump pit | |
| <input type="checkbox"/> No steps, ramps, or lips present | |
| <input type="checkbox"/> A smooth, hand-trowel finish | |
| <input type="checkbox"/> Incoming primary conductor conduits (at-grade vaults) | |
| INSPECTION #2 should be scheduled with the project's FCC when the above is complete and before the floor is poured. | |
| VAULT WALLS | |
| <input type="checkbox"/> Incoming primary conductor conduits (10' AFF for sub-grade vault) | |
| <input type="checkbox"/> Block outs for connection bus(es), vents (sizes, locations, height AFF) | |
| <input type="checkbox"/> Burke clutch receivers at 12" AFF: (number/locations on approved design/orientation/secured to rebar) | |
| <input type="checkbox"/> Burke clutch receiver at 10' AFF directly opposite primary conduits (if entering through the wall) | |
| <input type="checkbox"/> 250 MCM continuous grounding loop at 24" AFF (secured to rebar, number/type of attachment to electrode ground tails) | |
| <input type="checkbox"/> Brass grounding inserts (Lane Industries KBR R1238/26) number/location(s) per approved vault plan | |
| <input type="checkbox"/> Insert(s) at personnel and equipment access hatches (sub-grade) | |
| <input type="checkbox"/> Two Cadweld/crimp attachments to 250 MCM loop at 5' centers/24" AFF | |
| <input type="checkbox"/> Inserts secured to be flush with the finished wall | |
| <input type="checkbox"/> Sleeves through columns, 3/8" threaded inserts 8" out from corners and at doorways | |
| <input type="checkbox"/> Boxes and connecting conduits for wall lights/switches/outlets, emergency egress lights, per the approved vault drawing. Conduits run to the vault service panel location. | |

- Sleeves for A/C line sets
- Fire sprinkler heads (where required by local Fire Marshall)
- Embedded 1-5/8" x 1-5/8" galvanized Unistrut, 48" AFF, 8' long/transformer, directly below (sub-grade vault) or above (at-grade vault) incoming primary conduits.

INSPECTION #3 should be scheduled with the project's FCC when the above is complete and before the walls are poured.

VAULT CEILING

- Installation of wood-form insert (a.k.a. Blue Bangers; Simpson Strong Tie BBWF3762) grid, 12" from walls, 24" on center in the field
- Installation of ferrules for D-ring fall arrest anchors
- Boxes and connecting conduits for heat detectors
- Boxes and connecting conduits for access hatch switches ((lights/purge fan/sump pump) (sub-grade)) vault
- Blockout for exhaust fan/intake air
- Spread anchors directly above primary conduits (if entering through the floor)

INSPECTION #4 should be scheduled with the project FCC when the above is complete and before the ceiling is poured.

VAULT INTERIOR

- Application of approved paint on walls

Cable trays:

- Routing matches the approved vault drawing
- 1/2" threaded down rods (all material galvanized or equivalent)
- Seismic reinforcing and securement per supplier plan or seismic engineer
- Adequate support (no couplers in threaded rods, trapeze at all tray joints)

Connection bus(es):

- Match pre-approved shop drawing w/solid connection plates, 10" spacing, 6" from the wall, protective shield on face and ends of plates
- Seismic reinforcing and securement
- Adequate support to wall and ceiling
- Block outs fire caulked
- Plugs, switches, work lights, and emergency egress lights are installed.
- Sump pit cover and 2" drain line w/quick disconnect (male camlock) routed at 48" AFF, 3" off the wall, and secured at equipment door (at grade) or personnel access hatch (sub-grade)
- #6 grounding pigtailed attached to door frames, fire damper vents, and any accessible metal parts
- Heat detectors installed
- D-ring fall arrest hardware installed
- Vault service panel installed and labeled (NEMA 3 if sub-grade)
- Spread anchors not protruding from the finish floor/walls and not filled with concrete.
- Grounding inserts and wall anchors are visible and functional.
- 16" x 16" louvered vent and 30-amp twist plug receptacle for exhaust fan.
- No steps, lips, ramps, or non-vault equipment conduits are visible.
- A/C heads and thermostat (directions for controlling thermostat and heads accessible)
- Egress doors and panic hardware present
- Door sweeps installed and threshold present and sized with mounting grommets installed in the floor (at-grade vaults)
- Access paths for equipment installation are clear.

- Equipment and personnel access hatches (sub-grade) adjusted to final grade and drain lids connected to an outlet.
- Personnel access ladder installed, secured, grounded (sub-grade)

INSPECTION #5 should be scheduled with the project FCC when the above is complete, and the vault is ready for the transformer installation.

VAULT FINAL PGE INSPECTION

When all the above inspections have occurred and been approved by the FCC and the presiding jurisdiction has inspected and tagged the electrical switchboard in the electrical room, the project can contact PGE Service Coordination (503-323-6700) to request a final service inspection.

Successful completion of the Service Inspection final will allow for the transformer, conductor, and meter installation scheduling. Once transformer(s) and conductor are placed in the Class A vault, only PGE personnel will be allowed to enter. Any additional work by contractors or general maintenance by the building's ownership will require a PGE Safety Standby crew to open the vault and monitor non-PGE personnel while their tasks are completed. Safety Standby crews are requested and scheduled through PGE Service Coordination (503-323-6700) and generally require 30 days prior notice.



PGE Corporate Headquarters
121 S.W. Salmon Street | Portland, Oregon 97204
portlandgeneral.com