

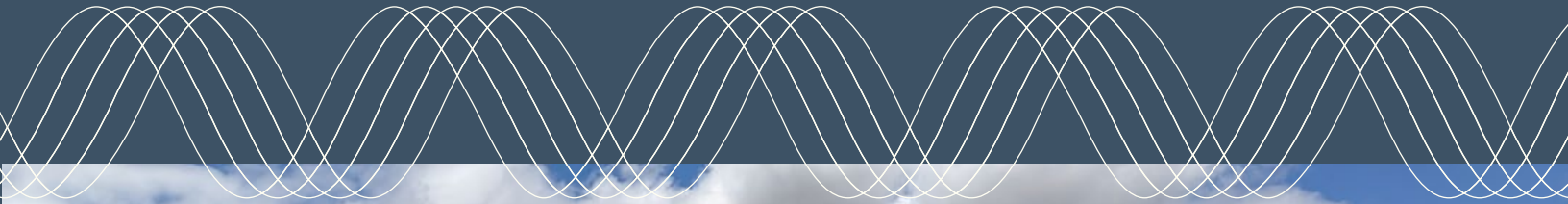

# Medium Voltage Service Requirements

## October 2024



---

Copyright © 2024 Portland General Electric.

All rights reserved. No part of this publication may be reproduced without the written permission of Portland General Electric.

Information in this document is accurate at the time of publication but is subject to change without notice.

Portland General Electric  
Distribution Engineering and Standards  
3700 SE 17th Avenue  
Portland, OR 97202

---

# Contents

Revision Log.....	5
Executive Summary.....	6
Accuracy of Information and Conflicting Requirements.....	6
Terms Used in the Medium Voltage Book.....	6
1 General Requirements.....	7
1.1 Types and Sizes of Medium-Voltage Service Furnished.....	7
1.2 Charges.....	7
1.3 Customer Responsibilities.....	8
1.3.1 Safety.....	8
1.3.2 Call Before You Dig.....	8
1.3.3 Installing and Maintaining Switchboards.....	8
1.3.4 Grounding And Bonding of Medium-Voltage Services.....	8
1.3.5 Protecting PGE Equipment with Barrier Posts.....	9
1.3.6 Additional Load For Existing Customers.....	9
1.3.7 Power Factor.....	9
1.3.8 Power Quality.....	9
1.3.9 High-Frequency Equipment and Harmonic Distortion.....	9
1.3.10 Voltage Disturbances and Fluctuations.....	10
1.4 Connecting and Disconnecting an Existing Service.....	10
1.5 Point of Delivery (POD).....	10
1.6 Load-Side Point of Isolation.....	10
1.7 Alternate Service Agreements.....	11
1.8 System Protection.....	11
1.9 Meter Equipment.....	11
1.10Motors.....	12
2 Responsibilities and Project Phases.....	13
2.1 Division of Responsibilities.....	13
2.1.1 PGE Responsibilities.....	13
2.1.2 Customer Responsibilities.....	13
2.2 Project Phases.....	14
2.2.1 Phase 1: Gear Design and Review.....	14
2.2.2 Phase 2: Pre-Construction Conference to Pre-Installation Inspection.....	18
2.2.3 Phase 3: Switchboard Installation to Energization of Service.....	19
2.2.4 Phase 4: Customer-Utility Lock-Out/Tag-Out Procedure for Planned and Unplanned PGE and Customer Outages.....	20
3 Access and Clearance Requirements.....	21
3.1 Access.....	21
3.1.1 Remote Meter Enclosure Location.....	21
3.2 Drivable and Accessible Surface for PGE Vehicles.....	21
3.3 General Clearance Requirements.....	22
4 Underground Requirements: Trenches, Backfill, and Conduits.....	23

4.1	Basic Requirements.....	23
4.1.1	General Customer Responsibilities.....	23
4.2	Trench Dimensions and Cable Separation.....	24
4.3	Marking Tape.....	25
4.4	Backfill .....	25
4.5	Conduit .....	26
4.5.1	Customer-Owned Conductors .....	26
4.6	Conduit Sweeps and Pull Lines .....	26
4.6.1	Duct Proofing.....	27
4.6.2	Conduit Locations.....	28
4.6.3	HDPE Duct and Connectors .....	28
4.6.4	Concrete Pad Installations.....	28
4.7	Concrete Vault Installations .....	29
5	Enclosure Requirements.....	31
5.1	General Enclosure Requirements .....	31
5.2	Compartment Labels.....	33
5.3	Pulling Section .....	34
5.4	Termination Compartment .....	34
5.4.1	Requirements for Both 12.47 kV and 34.5 kV Services.....	35
5.4.2	Additional Requirements for Services Up to 12.47 kV.....	36
5.4.3	Additional Requirements for 34.5 kV Services .....	37
5.5	Current Transformer Compartment.....	38
5.6	Voltage Transformer Compartment.....	41
5.6.1	Voltage Transformer Disconnect .....	42
5.7	Fuse Compartment.....	42
5.8	Remote Metering Enclosure.....	43
5.8.1	Additional Metering Requirements .....	43
5.8.2	Access Panel Requirements.....	43
5.9	Load-Side Disconnect Requirements.....	44
5.10	Grounding Switches in Customer Section(s).....	44
6	Instrument Transformer Requirements .....	45
6.1	General Instrument Transformer Requirements .....	45
6.1.1	Test Switches .....	45
6.1.2	Grounding Switches .....	45
6.2	Current Transformer for Utility Metering .....	45
6.3	Voltage Transformer for Utility Metering.....	46
7	Customer Generation.....	47
7.1	General Information .....	47
7.2	Disconnect Switch Requirements.....	47
7.3	Emergency or Standby Generator.....	47
7.4	Dispatchable Standby Generation or QF Greater than 3MW.....	48
Appendix A	Generic Vault and Switch Dimensions .....	50
Appendix B	Primary Meter Gear Inspection Checklists .....	53

## Revision Log

Date	Version	Revision Description
<b>5/20/2022</b>	1.0	Initial Publication
<b>5/12/2023</b>	2.0	Section 4, <i>Underground Requirements: Trenches, Backfill and Conduits</i> has been added. Content includes information on 8-inch conduit and sweep requirements. Appendix A was added providing generic vault and switch dimensions. Customers should no longer reference PGE's ESR section 6 for conduit requirements. PGE's standard for medium-voltage services as of May 2023 is to meter customers with a remote meter enclosure. All affected text has been modified.
<b>5/30/2023</b>	3.0	Minor formatting changes throughout.
<b>6/10/2024</b>	4.0	Term Used section added. UL-listed equipment is now explicit in language. Updates to DER requirements in light of IEEE changes, and safe work clearance requirements for crew work practices. Updates made to interlock requirements.
<b>10/22/2024</b>	5.0	Note for 16-week Protection Engineering relay setting review added to 1.8 and B.1.

---

## Executive Summary

This Medium Voltage Service Requirements book is designed to help you obtain electric service from Portland General Electric (PGE). The information in this book applies to both new services and rewired medium-voltage services.

The requirements are meant to be read and interpreted in their entirety. Individual figures or pages do not represent the complete requirements for service and should not be cited out of context.

**IMPORTANT:** Do not use figures in this book as construction plans by themselves. The text that accompanies a figure often contains important information that is not referenced in the drawing. Customers must reference an approved job sketch for site specific information.

## ACCURACY OF INFORMATION AND CONFLICTING REQUIREMENTS

The information in the Medium Voltage Service Requirements book is accurate at the time of publication but is subject to change without notice. While requirements are meant to comply with all governing codes, ordinances, and tariffs, these requirements may change. Always use the most recent publication of any code referenced in this Guide—such as the National Electrical Code (NEC), National Electrical Safety Code (NESC), or Oregon Electrical Specialty Code (OESC). If the information in this Guide conflicts with a code, ordinance, or tariff, the requirement(s) is supreme. PGE does not assume responsibility for keeping this book current and should be consulted when you have questions about the applicability of any of the Guide's content. While PGE may update this Guide from time to time, the online version always contains the most up-to-date and definitive information.

## TERMS USED IN THE MEDIUM VOLTAGE BOOK

The following list provides definitions for terms used in the Medium Voltage book.

Term	Definition
ANSI	American National Standards Institute.
DPM	Design Project Manager
EUSERC	Electric Utility Service Equipment Requirements Committee
Load-Side Disconnect	This is a customer owned and operated piece of equipment that provides a visual open downstream of the medium voltage PT, CT and load-serving metering cabinet. Customers with generation will require a line-side service disconnect, which serves as a load-side disconnect in a configuration where customer equipment may be energized. The load-side disconnect must be a blade-and-jaw type that is UL listed.
Load-Side Point of Isolation	The load-side point of isolation separates the customer's equipment from the PGE system and provides a visible open for establishing a clearance point for PGE personnel to work on PGE equipment upstream of the customer's equipment.
NEC	National Electrical Code
NESC	National Electrical Safety Code
OESC	Oregon Electrical Specialty Code
PGE	Portland General Electric

---

# 1 General Requirements

## TOPICS IN THIS SECTION

- Types and Sizes of Medium-Voltage Service Furnished
- Charges
- Customer Responsibilities
- Connecting and Disconnecting an Existing Service
- Point of Delivery
- Load-Side Point of Isolation
- Alternate Service Agreements
- System Protection
- Meter Equipment
- Motors

### 1.1 TYPES AND SIZES OF MEDIUM-VOLTAGE SERVICE FURNISHED

PGE's standard medium voltage service is a three-phase, 4-wire grounded wye, underground with maximum allowable loading of 600 A at 12.47 kV and 900 A at 34.5 kV. If loading requirements exceed these thresholds, contact PGE's Service Coordination team (503-323-6700) to start a Request for Service and discuss your project with PGE's Design and Regional Distribution Operation Engineers (RDOEs). All non-standard voltage requests (11.1 kV and 11.4 kV included) must be reviewed and approved by PGE prior to installation.

While PGE will not provide customers with a delta service, customers may operate a delta system so long as PGE's system protection, operations, and grounding requirements are met. Services that include a customer-operated delta system must be reviewed and approved by PGE.

**NOTE:** Overhead pole-mounted primary metered services are prohibited.

### 1.2 CHARGES

Electric service is supplied to customers under the rates, rules, regulations, and marketing programs approved by PGE's tariff. Rates for commercial and industrial customers are determined based on the amount of energy used at the site. Services usually have a basic monthly charge and fees based on the amount of electricity used. Please refer to the PGE tariffs at [PortlandGeneral.com](http://PortlandGeneral.com) for a complete list of rate schedules.

In general, customers who need medium-voltage service with primary metering receive a lower rate than secondary-metered customers. Because of the lower rate, customers with medium-voltage with primary metering are responsible for installing, commissioning, and maintaining all equipment beyond the point where ownership changes between PGE and the customer (the Point of Delivery, or POD). This includes (but is not limited to) cables, connectors, transformers, and switches. PGE may require minimum load agreements—please refer to [Section 1.5, Point of Delivery \(POD\)](#), for more information, and contact PGE's Service Coordination Team (503-323-6700) for help in determining the rate schedule for new or upgraded services.

---

## 1.3 CUSTOMER RESPONSIBILITIES

### 1.3.1 Safety

The customer must comply with all applicable federal, state, and local laws and regulations concerning activities in the vicinity of PGE electrical lines and equipment.

When PGE serves a customer by means of primary voltage circuits on the customer's premises, or a customer resells power and energy furnished by PGE, PGE requires them to obtain and maintain insurance coverage that PGE deems adequate to satisfy the duty of indemnification. PGE requires a separate indemnification, hold harmless, and/or additional named insured agreement.

### 1.3.2 Call Before You Dig

**IMPORTANT:** Before you dig, call 8-1-1 or 800-332-2344 to obtain the location of all underground utilities; or visit [callbeforeyoudig.org](http://callbeforeyoudig.org). In the Portland metro area, call 503-246-6699.

Oregon law requires a customer or excavator to call for locates of underground utilities two full working days (48 hours) before beginning excavation. The customer or excavator cannot start work until utility locations have been marked, or the utilities have informed the excavator that no facilities are located within the excavation area.

### 1.3.3 Installing and Maintaining Switchboards

The customer is responsible for the proper installation and periodic maintenance of all customer-owned equipment, including (but not limited to):

1. Overcurrent devices.
2. Cable and bus connections and terminations
3. All other electrical equipment.
4. Customer-owned equipment for 12.47 kV services must meet applicable EUSERC requirements and be listed with Underwriters Laboratories (UL). Customer-owned equipment for 34.5 kV services is required to be UL-listed.

### 1.3.4 Grounding And Bonding of Medium-Voltage Services

Grounding and bonding are crucial to safety and electrical reliability. PGE requires all medium-voltage service customers to meet applicable grounding, fault current, and arc flash requirements. The customer is responsible for ensuring that the electrical wiring and service equipment is grounded and bonded in accordance with applicable National Electric Safety Code, local ordinances, and PGE standards. Neutral-ground bond requirements are available in the [Medium-Voltage Example Drawing Package](#) document on [PortlandGeneral.com/esr](http://PortlandGeneral.com/esr).

**IMPORTANT:** If the customer's system includes any grounding switches, the switches must be interlocked to prevent grounding an energized PGE feeder or energizing the customer's system while grounded.



---

### 1.3.5 Protecting PGE Equipment with Barrier Posts

In locations where vehicles or other equipment can approach PGE facilities, PGE requires customers to provide barrier posts to protect PGE's electrical equipment. For more information, please refer to section 5.6.8, Barrier Posts, in [PGE's Electric Service Requirements \(ESR\) Book](#).

### 1.3.6 Additional Load For Existing Customers

The customer must give PGE prior written notice before adding load or modifying existing electrical equipment. For new renewable resources and generators, please refer to [Section 7, Customer Generation](#) and PGE's Distribution Interconnection Handout on [PortlandGeneral.com/renewable-installers](http://PortlandGeneral.com/renewable-installers). This notice gives PGE an opportunity to determine whether changes are needed to its distribution facilities. For more information, see PGE tariff Rule C, Conditions Governing Consumer Attachment to Facilities, on [PortlandGeneral.com](http://PortlandGeneral.com).

PGE provides service conductors and transformers to accommodate existing or calculated demand load. New and existing customer service equipment may have a larger load rating than the calculated or existing demand. PGE may provide a placard that indicates the need to verify service source capacity before adding load; when required, the placard must be installed on the customer's service termination equipment.

### 1.3.7 Power Factor

The current PGE tariff specifies a charge for low power factor for certain commercial and industrial customers. Low power factor may cause inferior performance of the customer's electrical system. PGE recommends that the customer install corrective devices to make the most effective use of the electrical system. If the customer wants to determine potential savings, PGE can provide a copy of the tariff. A second meter socket is not required to meter power factor.

### 1.3.8 Power Quality

The characteristics of the customer's electrical equipment and devices must allow the PGE distribution system to operate efficiently without undue interference to PGE service or to other customers. If a customer's equipment has characteristics that cause undue interference with PGE service or to other customers, that customer must make changes in that equipment or—at their own expense—provide additional equipment to eliminate the interference.

PGE reserves the right to inspect and test any equipment connected to its lines and to obtain any information necessary to determine the operational characteristics of that equipment. Before purchase, a customer must submit information to PGE regarding any equipment that might cause interference with service to other customers.

For more information on power quality, email [TCC.Power.Quality@pgn.com](mailto:TCC.Power.Quality@pgn.com) or call PGE at 503-736-5750.

### 1.3.9 High-Frequency Equipment and Harmonic Distortion

The effects of the design and operation of high-frequency equipment must not create disturbances on the PGE electrical system which interfere with any other customer's proper operation.

PGE has established limits on the maximum voltage distortion present on our distribution system and on the total harmonic distortion allowed. The customer must take actions necessary to filter devices that

---

can produce harmonic distortion so that distortion that results from these devices is kept within the limits specified in IEEE 519-2014, Section 10. Compliance with this requirement is determined by PGE measurement at the POD.

### 1.3.10 Voltage Disturbances and Fluctuations

Electric service supplied by PGE may be subject to voltage disturbances that will not normally affect the performance of typical electrical equipment. However, these disturbances may result in the improper operation of voltage-sensitive equipment. The customer must provide any power conditioning devices needed to obtain the quality of power necessary for optimum performance.

## 1.4 CONNECTING AND DISCONNECTING AN EXISTING SERVICE

Contact PGE's Service Coordination team ([Service.Coordinators@pgn.com](mailto:Service.Coordinators@pgn.com)) to schedule a connect/disconnect of a medium-voltage service. PGE personnel will identify what needs to occur to accomplish service shutdown.

## 1.5 POINT OF DELIVERY (POD)

Determining the POD is crucial to establishing the line of demarcation where PGE's equipment and responsibilities end and the customer's equipment and responsibilities begin. The POD for a medium-voltage service is the point at which PGE terminates its conductor or cables onto customer-owned bus work. The electrical equipment used for the POD must be located on a building's exterior and accommodate 24/7 access for PGE personnel. Written approval from PGE is required before the POD can be located anywhere except on the exterior of a building. The POD must be at or immediately upstream of PGE's metering equipment. Beyond the metering equipment, the customer is required to have a load-side point of isolation. No customer-owned equipment shall be installed upstream of the load side point of isolation.

The POD must be well-established, documented, and understood by both PGE and the customer.

Even though PGE does not own facilities beyond PGE's metering equipment, the customer may have equipment that is incompatible with PGE's system. In such cases, the PGE review process requires an evaluation of the customer system to ensure that downstream fusing, transformers, and other equipment will not cause any disruption of the distribution system.

## 1.6 LOAD-SIDE POINT OF ISOLATION

The customer must provide a load-side point of isolation in the switchboard. The load-side point of isolation separates the customer's equipment from the PGE system and provides a visible open for establishing a clearance point for PGE personnel to work on the PGE cable and equipment upstream of the customer's equipment. The load-side point of isolation must be a blade-and-jaw type that is UL-listed. PGE recommends means of ground attachment on the phase bus, for customer use, on the load-side point of the Load-Side Disconnect; the ball studs are a recommended solution. This equipment is in addition to any downstream protective device (such as a breaker or resettable fault interrupter) that may serve as means of energizing or deenergizing customer load. A rackable breaker is not an approved load-side point of isolation.

**IMPORTANT:** No customer equipment is allowed upstream of the load-side point of isolation.

---

Customers are responsible for operating (opening and closing) their load-side point of isolation for PGE personnel when requested, for planned or unplanned outages, 24 hours a day, 7 days a week, 365 days a year. PGE personnel are not allowed to operate customer-owned equipment.

**NOTE:** PGE may assign a PGE number to a customer-owned load-side point of isolation for operational visibility.

The load-side point of isolation should not be used to pick up customer load. PGE expects customers to use a customer-controlled, customer-side protective device (such as a breaker or resettable fault interrupter) to pick up load after a load-side point of isolation is closed and PGE energizes the primary metered service.

The customer's first protective device must be within 30 feet horizontally from the switchboard (30 feet maximum). A phenolic map should show the location of the device.

## 1.7 ALTERNATE SERVICE AGREEMENTS

When a customer requests an alternate service, additional reviewers are required during the application review phase. For more information, please refer to PGE's tariff.

## 1.8 SYSTEM PROTECTION

The customer is responsible for protecting their system equipment from power quality abnormalities. If the customer has any three-phase motors, the customer is responsible for protecting those motors against single-phasing system events as described in 1.3, "Motors," in in [PGE's ESR](#).

The customer's protective devices must coordinate with PGE's protective devices to isolate the utility system from disturbance on the customer-owned facility and prevent the customer from contributing to disturbances on the PGE system. Medium-voltage metered services must utilize an overcurrent protection (OCP) device, based on service amperage:

1. 200 A or less, with no generation, at 12.5 kV: Fuses may be used to provide overcurrent protection if acceptable coordination margins can be achieved with upstream devices.
2. Greater than 200 A at 12.5 kV, all 34.5 kV services, and all services with generation: Breakers or reclosers with microprocessor relays are required. PGE Protection Engineers can help resolve any questions related to system protection requirements.

**IMPORTANT:** Relay settings must be submitted to PGE Protection Engineering for review no later than 16 weeks prior to energization.

PGE Protection Engineers can help resolve any questions related to system protection requirements.

## 1.9 METER EQUIPMENT

Metal enclosures and customer-owned communications equipment often limit or interfere with PGE metering communication signals into outdoor customer-owned metering enclosures. PGE's standard for medium-voltage services as of May 2023 is to meter customers with a remote meter enclosure. The customer-owned remote meter enclosure must be attached to the exterior of the enclosure or placed within 50 feet of the switchboard. The customer must provide a 5-foot by 5-foot space for the remote meter enclosure. Customer-owned enclosures contain several different sections or compartments. Each section has different requirements, defined in more detail in [Section 5, Enclosure Requirements](#). PGE will provide customers meter equipment requirements during the design phase.

---

PGE may approve indoor metering equipment if—in PGE’s opinion—a suitable outdoor location does not exist. Approval for placement of the medium voltage switchboard anywhere other than exterior to the building is not guaranteed. PGE’s minimum requirements for indoor primary metering termination compartments are as follows:

1. Indoor metering must meet the requirements for medium-voltage equipment identified in [Section 3, Access and Clearance Requirements](#).
2. PGE requires all medium voltage interior installations to have 1.5-inch conduit from the electrical room to the exterior. This conduit will be used if metering communication signals are insufficient for reliable communication from the switchboard to the exterior. In this event, customers will be responsible for the costs of a solution (such as an antenna or post-mounted remote meter enclosure).
3. A 10-foot working clearance in front of termination section is required.
4. The electrical equipment room must be located on the exterior wall of the building with egress/ingress to the exterior. For detailed egress/ingress requirements, refer to Section 13, “Electrical Equipment Rooms and Interior Installations,” in [PGE’s ESR](#).
5. PGE must have 24/7 access to the room. For detailed access requirements, refer to Section 5, “Clearances and Location Requirements” and Section 13, “Electrical Equipment Rooms and Interior Installations,” in [PGE’s ESR book](#).
6. PGE vehicles must be able to approach the room to within 15 feet.
7. Additional requirements based on customer design and installation constraints will exist. PGE will provide these to the customer during the design and pre-construction phase.

## 1.10 MOTORS

To discuss the presence of a motor on an initial service or the addition of a new motor to an existing service, contact PGE’s Service Coordination team ([Service.Coordinators@pgn.com](mailto:Service.Coordinators@pgn.com)).

---

## 2 Responsibilities and Project Phases

### TOPICS IN THIS SECTION

- Division of Responsibilities
- Project Phases

#### 2.1 DIVISION OF RESPONSIBILITIES

Medium-voltage metered services require some functions and equipment to be completed and provided by the customer, and other functions and equipment to be completed and provided by PGE.

##### 2.1.1 PGE Responsibilities

PGE is responsible for the following:

1. Providing the PGE Design (i.e., Job Sketch) specifying the location and routing of all PGE facilities including any applicable poles, vaults, conduits, cables, conductors, switches, and the PGE line-side point of isolation.
2. Providing and installing all PGE conduit and line-side equipment as specified on the design.
3. Providing and installing meter(s).
4. Providing and installing meter test switches.
5. Providing and installing meter secondary wiring.
6. Providing current transformers (CTs) and potential transformers (PTs) for PGE metering use.
7. Providing fuses for potential transformers (PTs) for PGE metering use.
8. Verifying protection coordination with the customer's first protective device downstream of the load-side point of isolation, prior to energization.
9. Maintaining all PGE-owned equipment, including vault and conduit, after the energization of the service.
10. Coordinating with the customer on any planned shutdowns or other maintenance needs affecting operation of the service.

##### 2.1.2 Customer Responsibilities

The customer is responsible for the following:

1. Providing space on customer property for a PGE line-side point of isolation. PGE must be given ready 24/7 access via a paved or gravel road located a minimum of 5 feet, and a maximum of 15 feet, from the point of isolation. PGE's access must not be obstructed by a security fence, berm, or any other feature.
2. Ensuring 24/7 access to all PGE and metering equipment in the switchboard.
3. Maintaining and operating all customer-owned equipment.
  - a. For 12.47 kV: All hardware required to comply with EUSERC Section 400 and be UL-listed.
  - b. For 34.5 kV: All applicable hardware required to comply with EUSERC Section 400 and PGE requirements. PGE requires UL-listed equipment.

- 
4. Phenolic labeling as required by EUSERC 400 and PGE requirements. For more detailed information, refer to [Section 5.2, Compartment Labels](#).
  5. Providing and installing a load-side point of isolation to serve as visible open for PGE lock-out/tag-out procedures.
  6. Services with the potential for bidirectional flow, which includes all distributed energy resources (DER) services, must have a line-side disconnect. If an upstream point of isolation is not within 30 feet, then a line-side, gang-operated disconnect is required within the gear.

**IMPORTANT:** PGE highly recommends that customers install this proactively, even if no DERs are planned when the service is being designed.

7. A line-side point of isolation is required and will be addressed in PGE's design. In some circumstances, it may be beneficial to install a line-side disconnect in the customer gear.
8. Providing required workspace and clearances that meet or exceed NESC guidelines, PGE requirements, federal and Oregon OSHA rules, and other applicable code requirements. For more detail regarding PGE requirements, refer to [Section 3, Access and Clearance Requirements](#). PGE crews discourage line-side viewing windows.
9. The costs of providing and installing the service pathway, in accordance with the PGE tariff.
10. Installing a concrete mounting vault with a concrete pad at least 4 inches thick for the switchboard metering equipment.
11. Installing overcurrent protection downstream of the load-side point of isolation connected to the bus.
  - a. Protection settings for the first protective device downstream of the Point of Delivery (POD) must be provided to PGE.
  - b. Providing a digital (.PDF) service one-line diagram, showing the POD to the first protective device downstream and the first point of visual open past the load-side point of isolation.
12. Installing instrument (current and voltage) transformers provided by PGE for metering. The make and model of instrument transformers may vary for each installation.
13. Making provisions for PGE padlocks to facilitate PGE grounding and tagging processes.

**IMPORTANT:** Kirk® key locks are not approved for grounding and tagging purposes.

14. Coordinating with PGE when any planned activities could impact PGE's system and operations.

## 2.2 PROJECT PHASES

### 2.2.1 Phase 1: Gear Design and Review

At the beginning of a project, creating a development partnership between your project team and PGE is paramount to the successful and timely delivery of electrical service. Medium-voltage services require extensive planning that takes utility facilities, utility conflicts, safety clearances, and adherence to jurisdictional requirements and right-of-way (ROW) provisions into account. All medium-voltage services, regardless of voltage, are designed and constructed in compliance with PGE's standards and system protection and grounding practices, as well as NEC, NESC, and EUSERC requirements.

---

Key pre-design elements that inform PGE of the proposed configuration for the customer's service include the following:

1. Determining isolation points for the service to ensure that PGE's Line Operations and Meter Operations employees can safely work on the service and surrounding system.
2. Establishing a POD.
3. Identifying separation between customer's equipment and PGE equipment.
4. Coordinating PGE and customer protection.

The partnership will involve:

1. Discussing overhead and/or underground service options.
2. Evaluating possible meter locations based on PGE requirements and site-specific clearances.
3. Discussing any unique clearances and utility conflicts.
4. Understanding solar, battery, electric vehicle (EV), and other green energy goals.
5. Consideration of area lighting or streetlighting requirements.
6. Engineering review of:
  - a. Metering equipment.
  - b. Termination equipment.
  - c. Protection schemes.
  - d. Breakers and load-side ratings.

To initiate this discussion, submit a request for service (<https://portlandgeneral.force.com/powerpartner/s/login/>) PGE will contact you within five business days to discuss your project.

PGE's design timeline depends on timely submission of all required documents:

1. Site plan.
2. Electrical one-line.
3. Electrical three-line.
4. Electrical room layout, if applicable.
5. Control schematic.
6. Front-view or back-view layout of switchboard.
7. Top-view layout of switchboard
8. Interior view and measurements of all sections.
9. Current transformer and voltage transformer mounting.
10. Nameplates.
11. Mock-ups of required labels.
12. Elevation layout.
13. Bill of materials.

---

#### 14. Equipment specifications.

PGE needs these documents to develop the design, assess the suitability of proposed utility locations, and verify safety clearances. For an example submission package, please refer to the [Medium-Voltage Example Drawing Package](#) document on [PortlandGeneral.com](#). Please note that PGE does not accept very large (100 pages or more) drawing submission packages. Please provide all manufacturer specifications sheets in a package separate from the one containing your one-line, three-line, and other required documents.

PGE engineering and design teams will review the customer's documents and, in some cases, request additional details and/or clarification from the customer's team. The review with the project team and PGE teams will take time.

A pre-design meeting will be scheduled once PGE assigns a Design Project Manager (DPM). The customer project group attending the meeting should include the owner's representative, electrical engineer, architect, and any other parties the customer is consulting for the project. PGE representatives will include the assigned DPM, Trench & Conduit Inspector (FCC), Key Customer Manager (if assigned), and any other PGE teams required to support energization of the final service.

Once PGE has received a complete package of pre-design documentation from the customer, PGE will provide customers with a Design Commitment Date. Among other factors, the Design Commitment Date will depend on the following:

1. PGE's existing job queue
2. Weather
3. Timing of receipt of all required customer information
4. The amount of work in PGE's design queue

If additional documentation is needed by reviewing departments, the time required to obtain those documents will be added to the timeline (although not necessarily in a day-for-day ratio).

**IMPORTANT:** If changes are made to design documents, notify PGE as soon as possible by emailing the updated document and clearly detailing on the drawing and in the email the updates made to the original. While some changes may not require a re-design, other changes may require a complete re-design, reconsideration of on-site space, new equipment, and/or changes to the Design Commitment Date.

Once PGE provides an approved Job Sketch (i.e., Final Design), the customer has six months to return the signed line extension cost agreement (LECA), pay any costs due, and build and energize up to the POD. After six months, the LECA and the design must be reviewed by PGE, and revised if necessary, before moving to the pre-construction stage. If changes are made after the design has been approved by the customer and by PGE, a redesign fee may apply at the time of review.

PGE's Job Sketch or Final Design is the only approved plan for PGE-owned facilities; electrical or civil plan sheets from the customer's plan set that have been approved by the local jurisdiction's permitting authorities do not override PGE's design. It is the customer's responsibility to reconcile any differences between the PGE-approved plan sheet(s) and the public works and building plans.



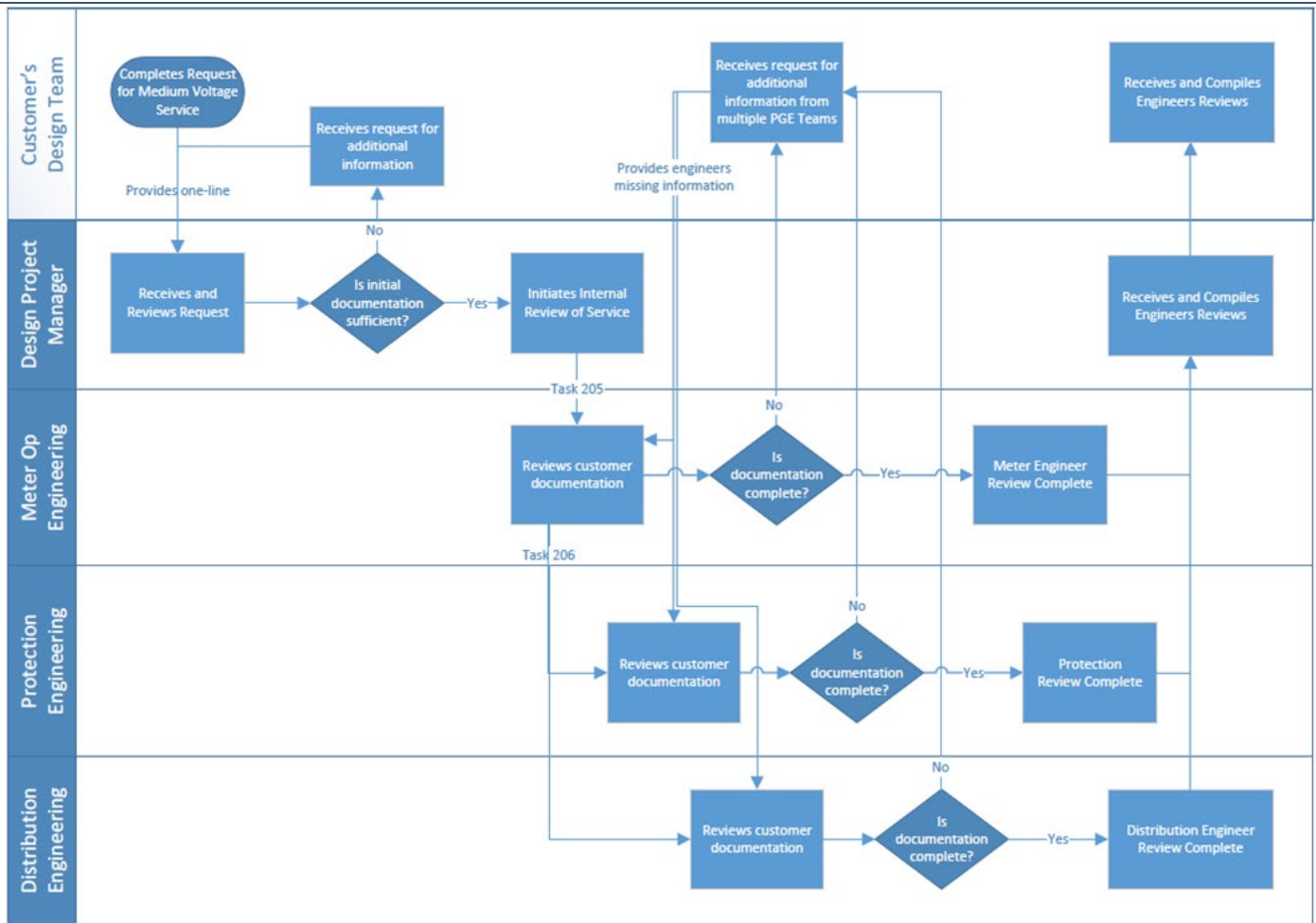

Figure 1: Phase 1—Gear Design, Review, and Approval

### 2.2.1.1 PGE Project Manager

PGE will assign a project manager following receipt of a Request for Service submitted via the PowerPartner portal (<https://portlandgeneral.force.com/powerpartner/s/login>).

### 2.2.1.2 Customer Generation

For customers installing generation on-site, there are additional requirements and steps that are not fully discussed in this document. A separate application, review, and approval is required for customer generation. Application information is available at [PortlandGeneral.com](http://PortlandGeneral.com).

For more detailed information, refer to [Section 7, Customer Generation](#).

### 2.2.1.3 Permits, Rights-of-Way and Easements

The customer is responsible—without cost to PGE—for the cost of all permits, rights of way, and easements required for the installation and maintenance of the electrical facilities that serve the customer.

On private property, an easement is required for the placement of electrical facilities (such as poles, guy wires, anchors, underground lines, transformers, vaults, junction boxes, and pedestals).

In the road right of way, a permit from the local jurisdiction is required before any work may be performed. Permits may also be required if the electrical facilities cross public property, railroad tracks, ODOT-managed highways, parks, or state/federal lands.

---

In the public right of way, only PGE-approved excavation contractors and contractors who have made special agreements with PGE are allowed to work under a PGE street-operating permit. Contact your PGE DPM to verify excavator requirements and verify that your excavator is approved. Customers must ensure that the excavator is approved prior to starting excavation work.

If the customer is operating under a PGE street-operating permit, the following steps are required:

1. PGE will acquire the permit and provide a copy to the contractor.
2. The contractor must notify the local jurisdiction before work begins according to the permit terms and conditions. Jurisdictions within the PGE service territory have varied requirements regarding the amount of lead time required.
3. A hard copy of the permit must be kept on-site at all times during construction.
4. All PGE trenches and conduits must be inspected by PGE before backfilling.

Upon completion, the contractor must submit a post-construction notification to the jurisdiction.

**IMPORTANT:** The contractor levels required for installation of a common vault on public and private property are listed in Appendix A. Vaults larger than 612 require a PGE-approved Level 2 contractor. Job specific vault contractor requirements are listed on the project Job Sketch.

## 2.2.2 Phase 2: Pre-Construction Conference to Pre-Installation Inspection

A Pre-Construction conference is required for all medium voltage services. This meeting occurs after the customer has received the PGE Job Sketch/Final Design, and associated documentation. During the conference, PGE personnel will review and verify clearances from the concrete pad and any other pertinent clearances.

Required attendees at the Pre-Construction conference include:

1. Customer's project manager.
2. Customer's general contractor.
3. Customer's electrician.
4. Customer's excavation contractor.

**NOTE:** Customer excavation contractors must be approved by PGE and have appropriate qualifications for the workspace. These qualifications must be verified prior to the Pre-Construction conference.

5. PGE DPM.
6. PGE Facility Construction Coordinator (FCC).

PGE Meterman/Service Inspector (if the customer switchboard is already on-site at the time of the Pre-Construction conference).

The customer must notify their PGE DPM when the switchboard is scheduled to arrive on-site and provide updates if significant delays arise, to allow PGE to inspect the switchboard prior to installation.

During this pre-Inspection, PGE will inspect the switchboard on-site to ensure that it is the same as the one reviewed by PGE during Phase 1. If the switchboard on-site differs from the previously reviewed

design, and PGE identifies issues with the on-site switchboard, the customer is required to address these issues prior to installation. PGE requires this pre-inspection of equipment to identify issues promptly and deliver safe, reliable, and affordable electric service.

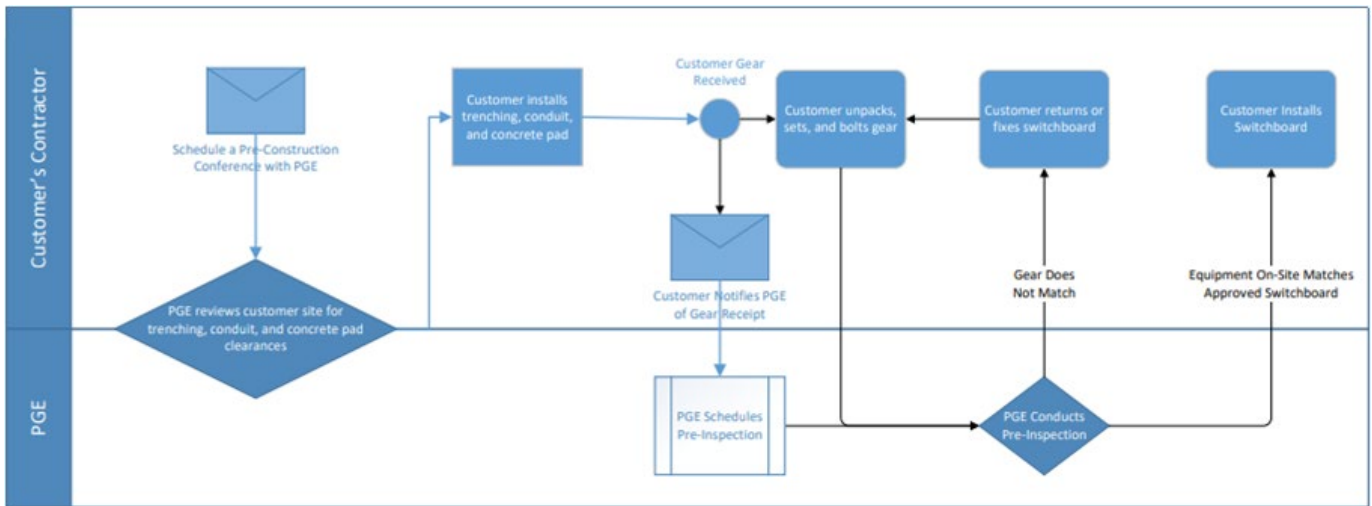

Figure 2: Phase 2 – Pre-Construction Conference to Pre-Installation Inspection

### 2.2.3 Phase 3: Switchboard Installation to Energization of Service

At this point, the customer must provide PGE with a timeline for installing the switchboard and energizing the service. If that timeline changes, the customer must promptly notify their PGE DPM. PGE schedules its crews several weeks out and must have advance notice to coordinate personnel for the pre-energization walkdown and for the energization and commissioning of the service.

Additional commissioning documents may be provided to customers.

Prior to energization, customers shall attest or validate MV equipment has been assembled and installed according to Original Equipment Manufacturer (OEM) instructions.

**NOTE:** Energization will occur a few hours or days following the pre-energization walkdown.

## Phase 3: Inspection and Energization Phase

Customer Installs Switchboard to PGE's Energization and Commissioning of the Service

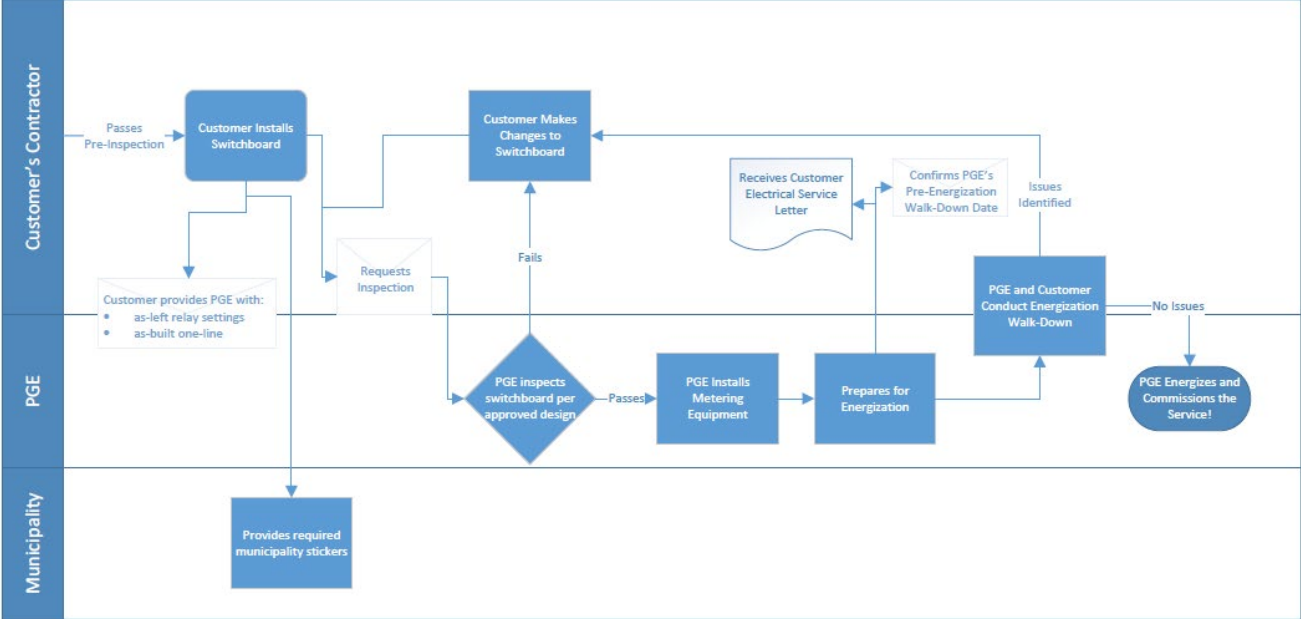

Figure 3: Phase 3 – Switchboard Installation to Energization of Service

### 2.2.4 Phase 4: Customer-Utility Lock-Out/Tag-Out Procedure for Planned and Unplanned PGE and Customer Outages

PGE requires visual opens on either side of a workspace to establish clear, safe working space. When PGE requires a visual open for planned or unplanned outages, customers are responsible for operating (opening and closing) the load-side point of isolation for PGE personnel.

**IMPORTANT:** PGE crews are not allowed to operate customer-owned equipment.

If you require a clearance for the medium-voltage metering gear, please contact PGE's Service Coordination team ([Service.Coordinators@pgn.com](mailto:Service.Coordinators@pgn.com)).

---

## 3 Access and Clearance Requirements

### TOPICS IN THIS SECTION

- Access
- Drivable and Accessible Surface for PGE Vehicles
- General Clearance Requirements

#### 3.1 ACCESS

PGE requires 24/7 access to the line-side point of isolation. If a fence is constructed, PGE must have keyed access. PGE does not allow the point of isolation to be inaccessible behind features such as fences, gates, or bushes.

PGE also requires 24/7 access to metering equipment. If this access is not provided by the customer, the customer must provide a remote meter enclosure located in an area that allows 24/7 access.

##### 3.1.1 Remote Meter Enclosure Location

If the meter is mounted to the switchboard, PGE requires the following:

1. Minimum 1-inch duct or PVC conduit from the current transformer compartment to the remote meter enclosure for secondary wiring.
2. Minimum 1-inch duct or PVC conduit from the voltage transformer compartment to the remote meter enclosure for secondary wiring.

If the meter is post-mounted within 50 feet of the switchboard, PGE requires:

1. Minimum 2-inch PVC from the switchboard to the remote meter enclosure for secondary wiring from the current transformer and voltage transformer compartments.

#### 3.2 DRIVABLE AND ACCESSIBLE SURFACE FOR PGE VEHICLES

PGE vehicles and equipment require drivable surfaces that exceed the dimensions of what is required for typical cars and trucks. PGE equipment must be located a minimum of 5 feet, and a maximum of 15 feet, from a 12-foot-wide paved road or compacted-gravel surface that allows for unrestricted access as documented in Section 5.5.3, "Drivable and Accessible Surface for PGE Equipment," in [PGE's ESR](#).

The following surface types are not drivable surfaces for PGE vehicles:

1. Sidewalks.
2. Lawns.
3. Landscaped areas.
4. Undeveloped and underdeveloped open areas.

---

### 3.3 GENERAL CLEARANCE REQUIREMENTS

The work performed by PGE line crews requires that a clear and level working area be maintained around electrical equipment. Clearances must not be obstructed by any structure, wall, landscaping, parking spot, fence, gate, or other obstruction. The customer must install and maintain landscaping in a way that prevents trees, shrubs, and other vegetation from interfering with the access, proper operation, or maintenance of PGE facilities.

For exterior services, PGE requires:

1. A minimum 60 inches (5 feet) of clear and level workspace in front of each metering section compartment.
2. A customer-installed concrete pad that extends a minimum 60 inches (5 feet) in front of the enclosure, with drainage that slopes away from the enclosure.
3. A minimum of 30 feet of vertical clearance above PGE pad-mounted metering equipment. Vertical clearance is assumed to be above the equipment, pad, and all clear spaces referenced above.

For all installations (interior and exterior), PGE requires:

1. A clear and level workspace that is 78 inches high and 60 inches deep around the cabinet, measured from equipment exterior.
2. A minimum 120 inches (10 feet) of clear, hard, and level workspace in front of the termination compartment.
3. The electrical room must be located on the exterior wall of the building with 24/7 access to the room.
4. The electrical room must be located a minimum of 5 feet, and a maximum of 15 feet, from a 12-foot wide paved or compacted gravel drivable surface that allows for unrestricted access.
5. Additional requirements will exist. Interior installations must meet the requirements specified in Section 13, "Electrical Equipment Rooms and Interior Installations" in [PGE's ESR book](#).

Additional clearance requirements likely exist. For more information on clearance requirements, refer to Section 6, "Clearances and Location Requirements" and Section 7, "Underground Requirements" in [PGE's ESR book](#).

## 4 Underground Requirements: Trenches, Backfill, and Conduits

### TOPICS IN THIS SECTION

- Basic Requirements
- Trench Dimensions and Cable Separation
- Marking Tape
- Backfill
- Conduit
- Conduit Sweeps and Pull Lines
- Concrete Vault Installations

### 4.1 BASIC REQUIREMENTS

**IMPORTANT:** If there are any changes to your project details (including elevation grade, landscaping, or building footprint), PGE will need to review the service entrance location again. Changes to a customer project can affect the trench depth, conduit, vault, barrier posts, and other PGE requirements.

#### 4.1.1 General Customer Responsibilities

The customer is responsible for trenching; backfilling; compaction; the installation of conduit and conduit markers; transformer pads or vaults; ground rods; and any other construction requirements for completion of underground service.

##### Plan

The customer must provide space for equipment (such as a transformer or vault) within the public utility easement (PUE) or on private property with a PGE easement.

1. Trench pathway—Trenches must be straight, with consistent depth and width, and follow the run line depicted on the PGE job sketch or mapped out with the FCC during the pre-construction meeting. For all trenching and transformer installations, the customer must meet any requirements of governmental authorities—including excavation permits—as well as those of PGE.
2. Contractor level—Trench work in a public right-of-way or PGE easement requires an excavator currently registered and in good standing with PGE Contract Services. PGE categorizes contractors as Level 1, 2, or 3. The PGE job sketch will indicate the contractor level required by PGE for the project. DPMs can assist customer in verifying the contractor level of PGE infrastructure being installed. When work in the right-of-way occurs under a PGE permit, the contractor must notify the local jurisdiction 48 hours before the work is to begin. A copy of the permit must be on site.
3. Pre-Construction Meeting—Medium voltage services require a Pre-Construction Meeting at the site with a Field Construction Coordinator (FCC). Customers are responsible for scheduling the meeting before they install the conduit.
4. Before backfilling, customers are responsible for scheduling an on-site inspection to verify that all requirements have been met.

---

## Prepare

1. Before you dig, call 8-1-1 for the location of underground utilities, or to have previous locates refreshed. For more information, see [Section 1.3.2, Call Before You Dig](#).
2. The customer must comply with Occupational Safety and Health Administration (OSHA) rules and Oregon Utility Coordinating Council (OUCC) standards. Refer to the Oregon Utility Notification Center's Standards Manual for additional information about customer responsibilities, including potholing. Potholing is required near existing trenches and when directional boring.
3. When a PGE standby crew is needed, schedule it several weeks ahead of time by calling Service Coordination. A PGE standby crew will observe when a customer penetrates into an energized facility. The customer is responsible for supplying the equipment and manpower.

## Protect

1. Obtain appropriate materials to cover, mark, and protect the excavation consistent with the local authority having jurisdiction and state OSHA rules, regulations, and statues.
2. Appropriate materials are required for road plating and cover of exposed pits.
3. Excavated soil must be placed a minimum of 24 inches from the field edge of the trench. If this is not possible, trench shoring may be required to comply with OSHA rules. Spoil may be placed in the street if approval is received from the local jurisdiction.
4. Water and runoff must be removed from trench until conduit is inspected.
5. Upon request, a PGE standby crew will be scheduled to observe when a customer is penetrating into an energized facility. The standby crew will open the facility to confirm conduit entry/exit and will serve as safety watch for the customer or customer's contractor.

**IMPORTANT:** Do not undermine PGE equipment—including underground cable, transformers, vaults, or poles—unless approved by a PGE standby crew.

## 4.2 TRENCH DIMENSIONS AND CABLE SEPARATION

Trench designs must provide suitable protective earth cover and separation between PGE-energized cables and other joint trench utilities along the entire trench length. Greater depths may be required by local jurisdictions. Actual cover is often contingent on the vertical height of the factory sweeps selected.

On public property, no water or sewage pipe may be in the same trench as PGE conduit. Clearances to water or sewage facilities in public ROW may vary by jurisdiction.

**NOTE:** Finished grade **must** be established before trench excavation to ensure that minimum cover requirements for cables and conduits are met. Minimum cover requirements for cables are measured from the trench surface to the top of the cable or conduit.



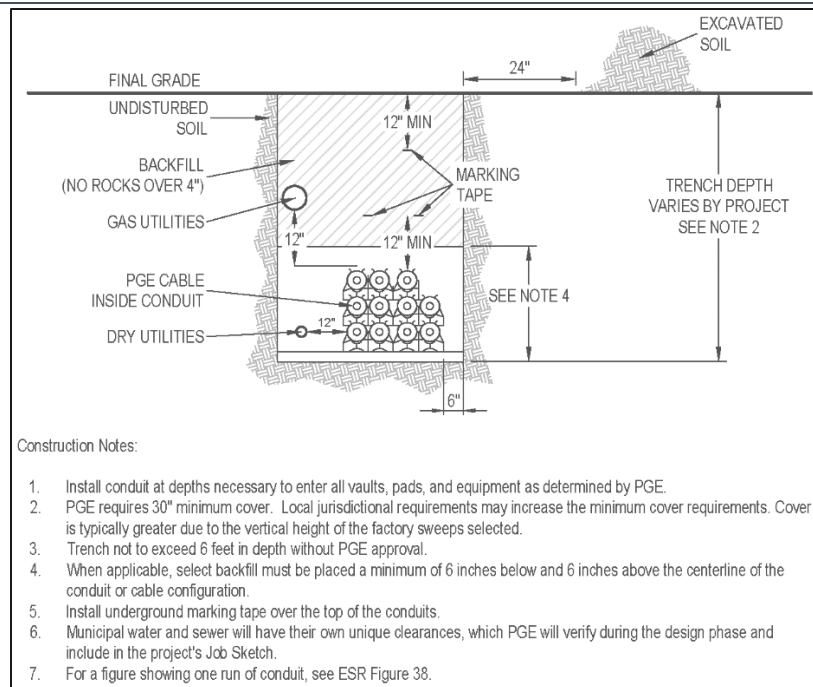

**Figure 4: Trench Dimensions and Cable Separation (STD-D-3106)**

### 4.3 MARKING TAPE

Red underground marking tape is required 1 foot above buried ducts or conduits and 1 foot below final grade. For conduit packages wider than 24 inches, two runs of tape are required. The tape runs must be at least 15 inches apart and centered over the conduit package.

### 4.4 BACKFILL

To ensure safe and reliable service for medium voltage services, PGE's standard is to backfill trenches in the right-of-way with native backfill material, or select backfill, unless soil conditions, a road-crossing, or other conditions indicate otherwise.

When on-site backfill contains rocks larger than 4 inches or rocks with sharp corners, select backfill or backfill processed on-site must be used. Either backfill must be placed at least 4 inches below and 6 inches above the conduit or cable configuration.

Select backfill material is granular material that meets the following standards:

1. 100% of the material passes a 3/4-inch sieve.
2. No more than 12% of the material passes a No. 200 mesh sieve.
3. The material is reasonably free of organic and otherwise undesirable materials.

Generally, 3/4-inch minus meets these criteria. Backfill in the remainder of the trench must be free of rocks larger than 4 inches in diameter.

If PGE requires mechanical protection for extremely adverse ground conditions or if minimum depth requirements cannot be met, see [ESR 6.2.5](#) for mechanical protection requirements. Otherwise, customers should not install mechanical protection, even on customer property, without written PGE approval. When PGE approves mechanical protection, rebar should never be installed within the mechanical protection.

If PGE requires Controlled Density Fill, see [ESR 6.2.6](#) for requirements.

---

## 4.5 CONDUIT

**Types of Conduit:** Rigid steel or electrical-grade Schedule 40 gray PVC conduit is required.

Conduit Routes:

1. Before any conduit is installed, routes must be approved by PGE. If rock or other obstructions are encountered during construction, consult PGE to discuss the route.
2. Conduit is prohibited under bodies of water, buildings, decks, or other structures.
3. When conduit terminates at a PGE pole, consult PGE for the exact conduit location. (Please refer to the current edition of the [ESR](#) for details).
4. All PVC joints must be glued.
5. All factory-cut and field-cut conduits must be chamfered to prevent damage to PGE cables.

**Conduit Risers:** All service conduit riser elbows must be backfilled at least 4 inches deep with tamped 3/4-inch minus crushed rock to avoid damage to underground conductors and service equipment caused when soil settles. Steel risers may be required on risers that face traffic.

Conduit Clearances and Spacers:

1. PGE requires the conduits to be horizontal in the trench, unless approved by PGE for a vertically stacked configuration. Contact PGE for approved conduit spacers.
2. When multiple conduits are present, conduits must have a minimum of 3 inches of clearance between the outside of conduit walls.

**Electrical Room:** Interior medium voltage installations must have 1.5-inch conduit from the electrical room to the exterior of the building.

**NOTE:** Consult PGE Meter Services for the location of this conduit.

**Remote Meter Enclosure:** Requirements, including conduit requirements, are in [Section 3.1.1, Remote Meter Enclosure Location](#).

**IMPORTANT:** PGE will not install a conductor if the conduit system is improperly constructed. The customer is responsible for repairing—or for the costs associated with repairing—any conduit problems before installation of a PGE conductor. PGE will own and maintain the conduit system once a PGE conductor has been installed.

### 4.5.1 Customer-Owned Conductors

The customer's service conductors must be in a separate conduit system from PGE conductors.

## 4.6 CONDUIT SWEEPS AND PULL LINES

### Capping and Pull Tape

1. Cap all conduits at both ends during installation to keep them free of dirt and debris.
2. All 8-inch conduits must have a 2,500-pound-rated woven polyester pull tape (such as Mule Tape® or Herculine®) with a minimum of 6 feet of line extending from each end of the conduit and tied to the vault door. The pull line must be installed after the conduit is joined and the glue is dry.

**Couplings:** Each sweep must have two extra-deep, fabricated PVC couplings.

**Sweeps and Couplings:** Each sweep must meet the requirements for iron pipe size (IPS) design in NEMA TC 14, Reinforced Thermosetting Resin Conduit (RTRC) and Fittings.

**Installing Existing PGE Energized Equipment:** Where a new conduit and/or pull line will be entering an existing PGE energized equipment, the installer is required—before installation—to schedule a PGE standby crew. The standby crew will meet the installer at the site on the day when the installer will be penetrating the PGE equipment.

**IMPORTANT:** All bends must be factory made. Field bends or field heat bends are not acceptable.

1. All primary cables in 8-inch duct must have fiberglass or rigid steel conduit sweeps. All conduit 6-inches and smaller require fiberglass or rigid steel conduits if the run is greater than 150 feet or if the total degrees of sweeps in the run exceeds 180 degrees. See [Figure 5](#) for conduit sweep radii.
2. The sum of conduit sweeps in a single run must not exceed 270 degrees regardless of the conduit type.
3. When installing 8-inch conduits, Sweeps must be separated by a straight section at least 10 feet long. There must be an initial horizontal straight section of at least 10 feet long beginning from the vault. When installing 6-inch or smaller conduits, sweeps must be separated by a straight section of at least 5 feet long. There must be an initial horizontal straight section of at least 3 feet beginning from the vault. Any exceptions to minimum straight section lengths between sweeps must be approved by the FCC.

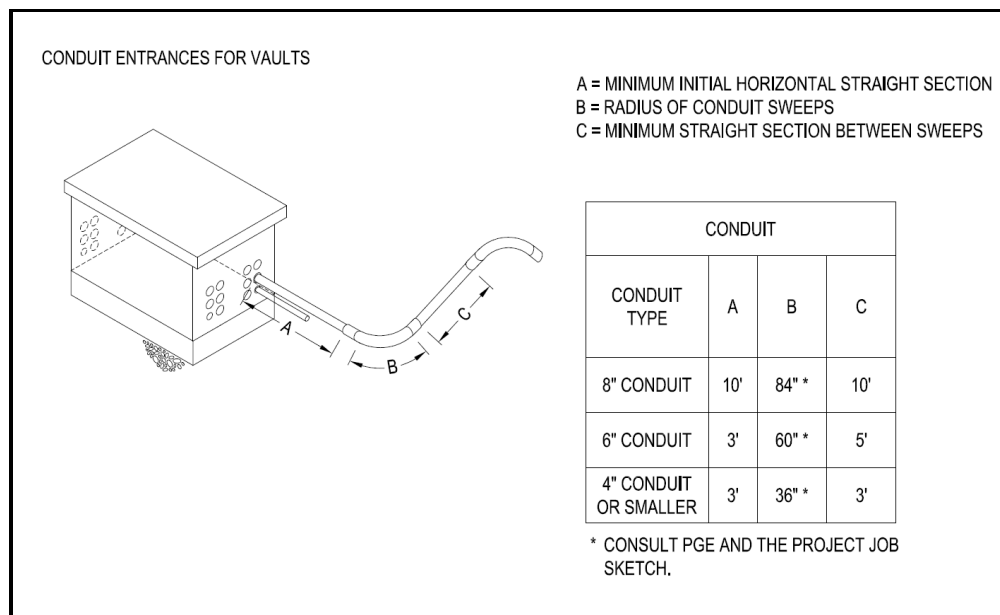

**Figure 5: Conduit Entrances for Vaults (STD-D-3311)**

#### 4.6.1 Duct Proofing

Duct proofing is a process used to ensure that a duct is clear of obstructions and grit, and that no portion of the duct is collapsed or out of round. The customer is responsible for duct proofing all ducts installed for PGE jobs before the job is completed and before the installation of PGE conductors.

To test for obstructions and out-of-round ducts, a wood test mandrel (or equivalent plastic and/or hard rubber mandrel) configured for the installed duct's inner diameter (ID) must be pulled through the ducts.

The customer must furnish the appropriate duct-proofing tool, such as a duct brush or steel or polyurethane duct checker.

## 4.6.2 Conduit Locations

During construction, the customer must mark conduit locations with white paint or other marker, such as a plastic strip in accordance with Oregon Administrative Rules (OAR) 952-001-0070.

Customers must label what PGE mount (vault, pole etc.) conduit runs go to on the vault wall next to the conduit. Labels should be made with a black, wide-tip permanent marker, or by using similar products such as a dark-colored concrete marker. The conduit label must be legible when standing within the vault.

## 4.6.3 HDPE Duct and Connectors

HDPE duct may be used for horizontal directional drilling (HDD) applications. Schedule 40 mechanical-interlocking PVC duct may be used as an alternative to HDPE duct when directional boring is required. For safety reasons, all HDPE ducts must be black with three equally spaced extruded red stripes.

HDPE duct sections must be joined by mechanical fittings that have barbed threads on both ends or by a swedge coupler with two-part conduit adhesive (like BonDuit). The duct must meet the requirements of PGE specification LC20515, which is available on request from a PGE Design Project Manager. Contact PGE's Field Construction Coordinator (FCC) when using HDPE duct.

All HDPE direct-bore installations (regardless of length) must use a 2,500-pound-rated woven polyester pull tape (such as Mule Tape® or Herculine® for all brushing and mandrel proofing of the conduit. A single continuous non-spliced run of tape must remain within the conduit.

## 4.6.4 Concrete Pad Installations

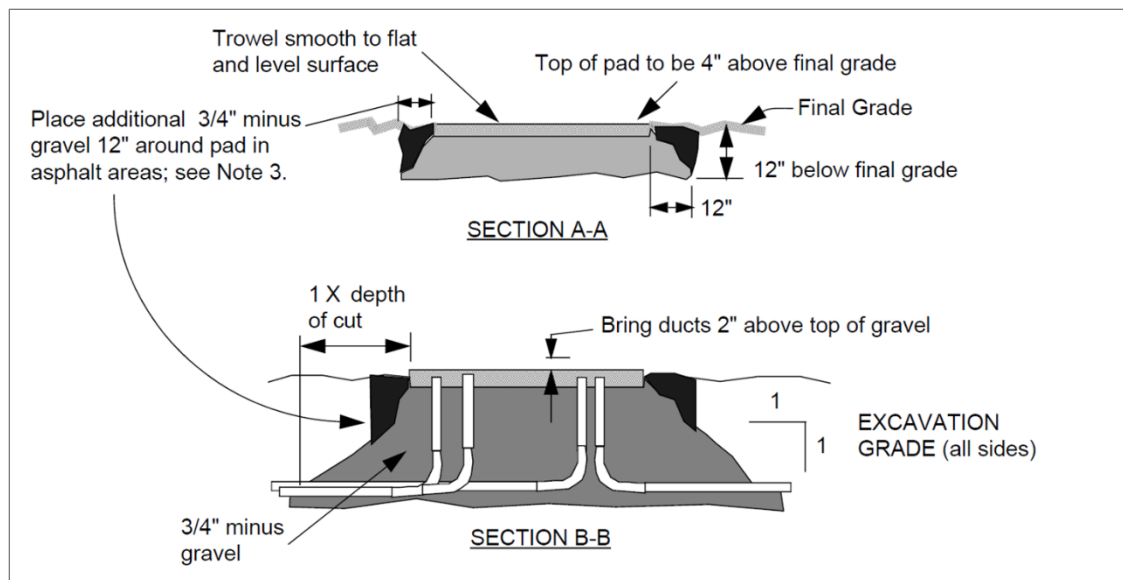

Figure 6: Concrete Pad Installation with Finished Grade

### Process:

1. A PGE DPM will determine whether a vault design is required for the project and will detail this on the Job Sketch.

- Customers are responsible for obtaining approved materials and preparing the site for the pad. A list of approved vault manufacturers is available on PortlandGeneral.com.
- An FCC inspection of the pad and conduit is required before the vault is backfilled.

**IMPORTANT:** Incorrect placement or final grade of PGE facilities are the customer's responsibility to correct. Reference your PGE Job Sketch for the required location.

- During construction, the customer must mark conduit locations with white paint or other marker, such as a plastic strip in accordance with Oregon Administrative Rules (OAR) 952-001-0070.

#### Requirements to Prepare the Soil for a Pad:

- Excavate the entire area to a minimum depth of 12 inches to 18 inches below final grade of the pad. The conduit install will likely require excavating well beyond the minimum.
- To prevent settling, all soil beneath the pad site must be compacted and level before setting pad. A compaction test may be an additional requirement.
- Install conduit sweeps deep enough to allow for a straight stub projecting a minimum 12 inches above final grade.
- Backfill with, and compact  $\frac{3}{4}$  minus gravel so that the top of the pad sits 4 inches above final grade, unless directed otherwise by the FCC.
- Lay an area of  $\frac{3}{4}$ -inch minus gravel at least 12 inches wide around all sides of pads that are located within blacktop surfaces.

Customer engineering should determine the pad thickness required based on site conditions and equipment residing on it.

## 4.7 CONCRETE VAULT INSTALLATIONS

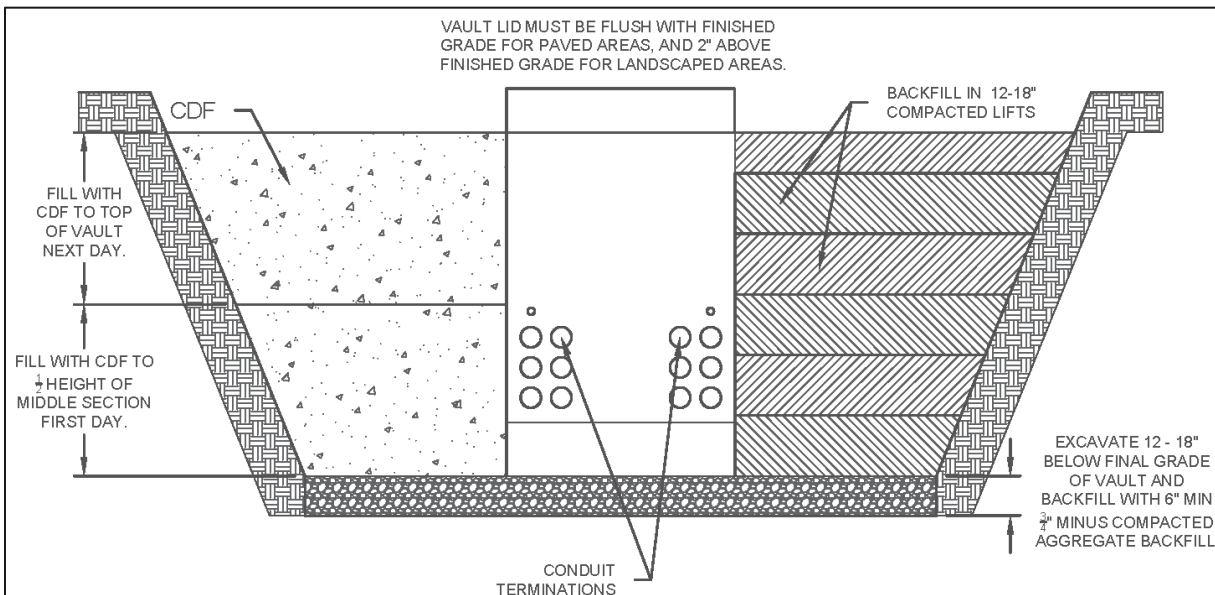

Figure 7: Vault Backfill Requirements (STD-D-3115)

#### Process:

- A PGE DPM will determine whether a vault design is required for the project and will detail this on the Job Sketch.

- 
2. Customers are responsible for obtaining approved materials and excavating the vault or handhole location. A list of approved vault manufacturers is available on [PortlandGeneral.com](http://PortlandGeneral.com).
  3. An FCC inspection of the vault and conduit is required before the vault is backfilled.

**IMPORTANT:** Incorrect placement or final grade of PGE vaults are the customer's responsibility to correct.

### **Pre-Cast Concrete Vault Requirements**

1. PGE needs survey references for elevations, right of way, private property, and vault locations based on civil infrastructure documents.
2. Vault risers may be required. Refer to the approved job sketch.
3. The 8 and 10 series vaults require "pick plans" prior to installation. Specific guidance will be supplied by the DPM and FCC.
4. Excavate the entire area beneath the vault to a depth of 12 to 18 inches below final grade of the vault. To prevent settling, all soil beneath the vault site must be compacted and level before setting the vault. Backfill base 6 inches with 3/4-inch minus gravel. Compaction is required. A compaction test may be an additional requirement at the discretion of the FCC.
5. Conduit must enter pre-cast vaults through conduit terminations or a cut and poured 'window'. Do not core into a vault. Use conduit terminations and/or knockouts.
6. Backfill in 18-inch lifts.
7. When vaults are installed, the customer is responsible for providing survey references to their contractor, including but not limited to: offsets from other utilities, final vault corners, vault elevations, final curb and or sidewalk locations and elevations.

---

## 5 Enclosure Requirements

### TOPICS IN THIS SECTION

- General Enclosure Requirements
- Compartment Labels
- Pulling Section
- Termination Compartment
- Current Compartment
- Voltage Transformer Compartment
- Fuse Compartment
- Metering Compartment
- Load-Side Point of Isolation Requirements
- Grounding Switches in the Customer Section(s)

### 5.1 GENERAL ENCLOSURE REQUIREMENTS

Metering medium-voltage customers within a customer enclosure is the most common form of primary metering, and is the form preferred by PGE. This type of metering can be done in the following conditions:

1. Outdoors or indoors. However, PGE's standard is outdoor metering. Refer to [Section 1.9, Meter Equipment](#), for more detailed information on indoor metering.
2. On general-purpose feeders or dedicated feeders.
3. At up to 600 A at 12.47 kV and up to 900 A at 34.5 kV.

If loading requirements are greater than those listed here, contact PGE.

Customer-owned enclosures have several different sections or compartments, each of which has different requirements (identified below). In general, the overall enclosure must meet these requirements:

1. Minimum ratings:
  - a. For 12.47 kV: 15 kV, 95 kV basic impulse level (BIL), and 25 kA short-circuit current rating (SCR).
  - b. For 34.5 kV: 38 kV, 150 kV basic impulse level (BIL), and 25 kA short-circuit current rating (SCR).
2. A clear and level workspace that is 78 inches high, 60 inches deep, and as wide as the PGE metering equipment and customer enclosure.
3. Enclosure must meet the requirements of NEMA 3R for weatherproof enclosures.
4. Enclosure doors must open to a minimum angle of 90 degrees and be able to lock in the open position at a minimum 90 degrees.
5. Customer-owned equipment (including lightning arrestors) is not allowed in the utility-controlled pull/termination section and line-side of the metering equipment.

6. No interlocks (e.g., kirk key disconnects) are allowed on PGE accessible or operable devices, or cabinets, except as listed in [Section 5.6, Voltage Transformer Compartment](#). PGE prefers that customers not install interlocks on load-side disconnects.
7. The current transformer and voltage transformer compartments must contain lifting eyes above each transformer to aid in installation. The lifting eyes must have at least a 200-pound rating to support the standard transformers referenced below.
8. All compartment doors must be hinged and lockable using a standard padlock (5/16-inch shaft).
9. PGE requires two hinged, clear, polycarbonate insulating barriers. The polycarbonate (Lexan or Makrolon, for example) must be electrically insulative, transparent, and meet applicable codes (such as NEC and UL). Each barrier must be at least 1/4-inch thick.
10. Barriers are required in these locations:
  - a. Between metering current transformers (CTs) and the access door. This barrier must be hinged to allow unobstructed access to the metering CTs and bus as shown in [Figure 13](#).
  - b. Between the termination lugs and the access door. This barrier must be hinged to allow unobstructed access to the terminations as shown in [Figure 10](#).
11. All installations must meet remote meter enclosure requirements described in [Section 1.9, Meter Equipment](#), [Section 3.1.1, Remote Meter Enclosure Location](#), and [Section 5.8, Remote Metering Enclosure](#).
12. All installations must meet the working clearance requirements described in [Section 3.3, General Clearance Requirements](#).

**NOTE:** When PGE approves an interior installation, a separate pad is not required. However, water mitigation (drainage) is required.

The figure below shows typical compartment layout and electrical one-line for each section.

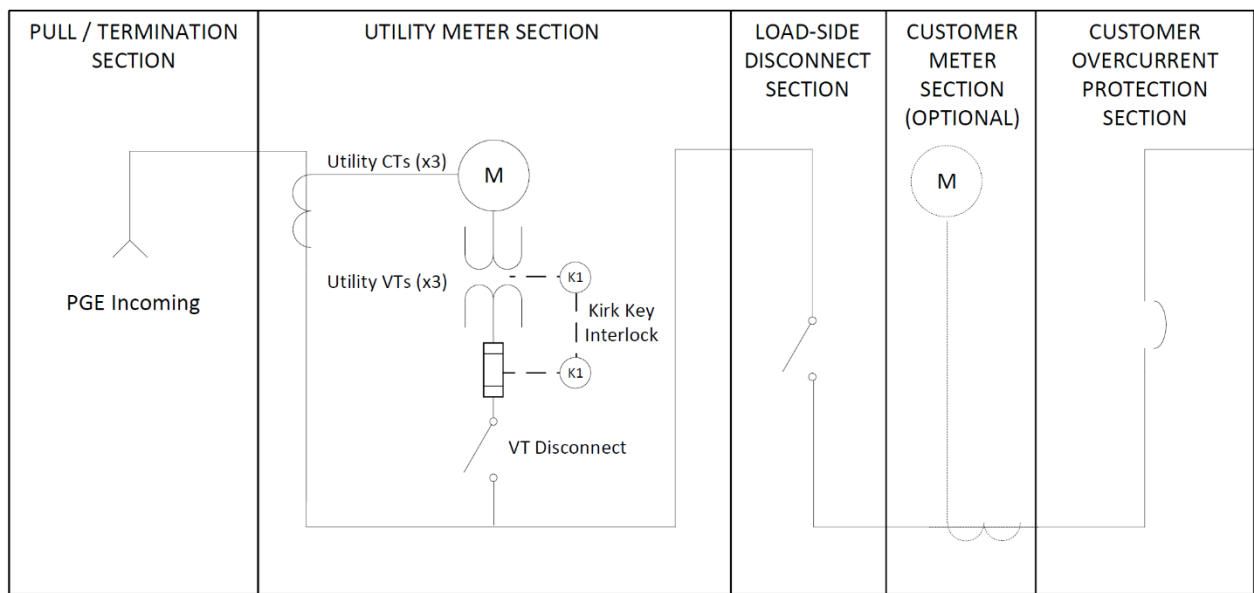

**Figure 8: Compartment Layout and Electrical One-Line**



---

## 5.2 COMPARTMENT LABELS

PGE requires all labels to be on the outside of the outer-most cabinet door so that details are visible without accessing equipment doors. Labels must correspond exactly with the equipment contained within the compartment. The equipment in the compartment must be accessible from the side to which the label is affixed. If equipment is accessible from both sides, labels are required on both sides.

To ensure safety, effective maintenance and reliable operation, each section compartment must be permanently labelled with machine-engraved, laminated, red phenolic tags with minimum 1/4-inch white text. PGE requires all of the labels described in EUSERC 400, plus the following labels:

1. A one-line diagram label in phenolic red affixed to the exterior of the outer most door of the compartment). Refer to the Example Drawing Package for an example one-line.
2. *Utility Voltage Transformer Compartment* label on the exterior of the switchboard.
3. *Utility Voltage Transformer Fuse Compartment* label on the exterior of the switchboard.
4. *Utility Current Transformer Compartment* label on the exterior of the switchboard.
5. *Utility Service Termination Compartment* label on the exterior of the switchboard.
6. *Utility Metering Compartment* label on the exterior of the switchboard.
7. *Utility Load-Side Point of Isolation* label on the exterior of the switchboard.
8. *Utility Line-Side Disconnect* label. If a utility line-side disconnect is present, it must be labeled on the exterior of the switchboard.
9. *Voltage (Voltage Magnitude)* label on the exterior of the switchboard.
10. *Voltage Phase (A, B, C)* labels in safety yellow color located within the termination section.
11. A phenolic map (mimic bus) on the switchboard showing the location of the first protective device.

If customer generation is on-site, an additional label is required (see [Section 7, Customer Generation](#)).

In addition, during lock-out tag-out procedures for planned and unplanned outages, the customer's on-site personnel may need to quickly operate customer-owned equipment. In PGE's experience in responding to unplanned outages, customer personnel benefit when all of the following customer equipment is clearly labelled:

12. First breaker beyond the Point of Delivery.
13. First control power transformers beyond the Point of Delivery.
14. First potential transformer beyond the Point of Delivery.

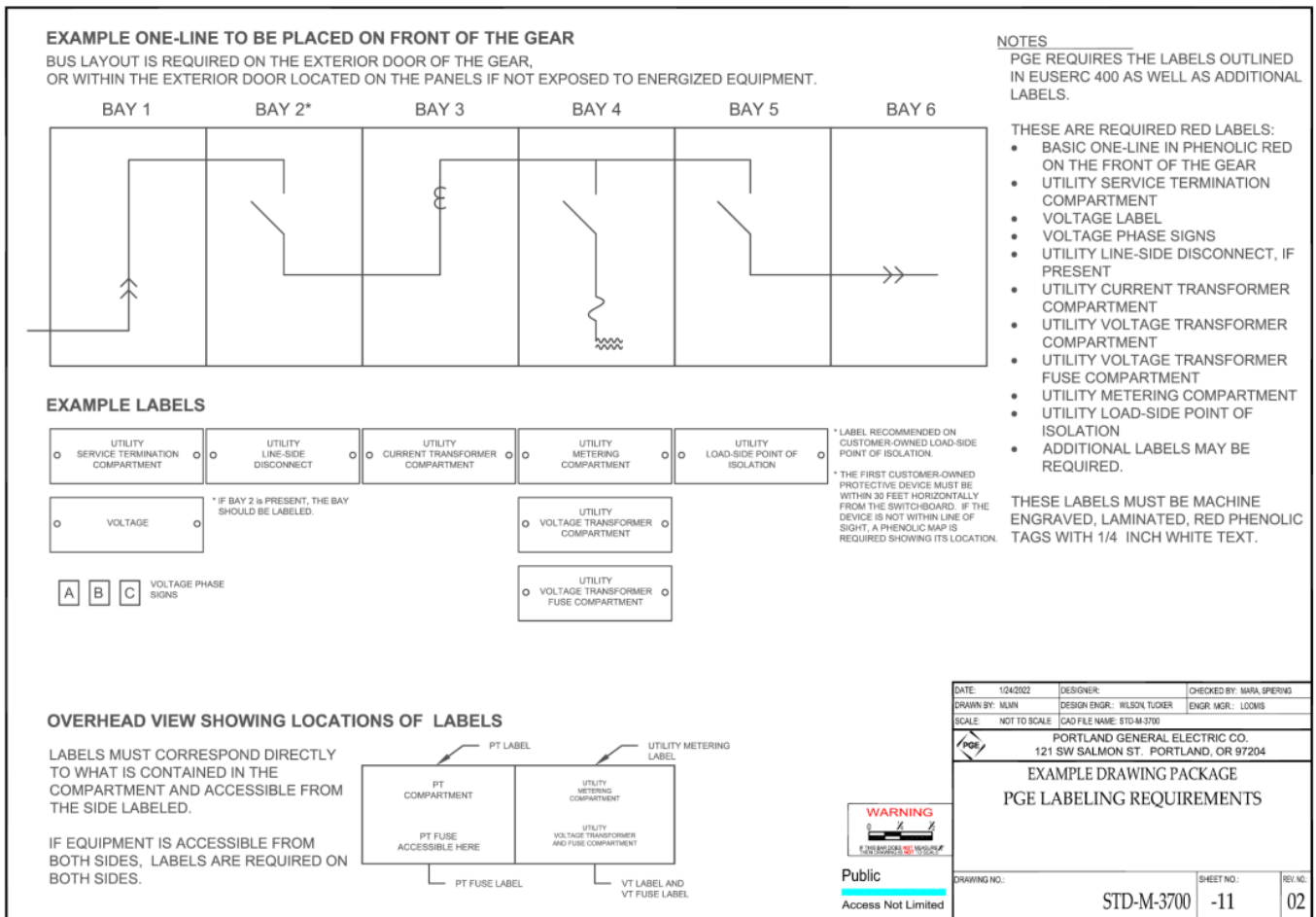

Figure 9: PGE Labeling Requirements

### 5.3 PULLING SECTION

The cable pull and termination areas are generally located in the same equipment section. A separate pull section (when present) is solely for facilitating the installation and removal of service cable. Other equipment may not be placed in the pull section.

A separate pulling section is not required for medium-voltage metering installations, as long as the following requirements are met:

1. The enclosure is located on the ground floor of the building, or at grade on the building exterior.
2. Penetration into the meter equipment is through the bottom of the termination section.
3. Required working clearances are met.
4. Required termination heights are met. The pulling section must be accessible as defined in [Section 3, Access and Clearance Requirements](#).

If the above requirements are not met, PGE will likely require a separate cable pull section.

### 5.4 TERMINATION COMPARTMENT

The termination (cable-pulling) compartment must meet the clearances defined below. The cable termination section is solely for terminating cable, and no other equipment may be placed in it. Termination section bracing must not interfere with cable installation.

---

### 5.4.1 Requirements for Both 12.47 kV and 34.5 kV Services

For 12.47 kV and 34.5 kV services, the termination section must meet these requirements:

1. Terminations must be between 62 inches and 78 inches from the bottom of the cabinet.
2. Conduit that enters the termination section may extend a maximum 3 inches above the bottom of the cabinet.
3. A minimum 0.25-inch clear polycarbonate insulating barrier is required between the termination lugs and the access door. The polycarbonate (such as Lexan or Makrolon) must be electrically insulative, transparent, and meet applicable codes (NEC, UL). This barrier must be hinged to allow unobstructed access to the terminations as shown in [Figure 10](#) and [Figure 11](#).

To facilitate effective grounding at the customer's switchgear utilizing PGE's standard grounding equipment, PGE requires customers to provide three ball-ground studs on the ground bus, plus one additional ball-ground stud on each phase bus inside the termination compartment.

All ball-ground studs must be compatible with a copper bus, and each stud must have the following:

1. A 30 mm ball
2. Shaft length between 0.5 inch and 1 inch
3. 0.5-inch-13 threads with insulating covers
4. A minimum fault rating of 25 kA at 15 cycles

The customer must provide an insulated landing pad for neutral termination. The neutral must be physically connected to the ground bar in the termination section and continue to the load-side point of isolation.

The customer must also provide an insulated neutral pad with NEMA 4-hole pattern in the CT section.

The ground bus must be located on the same side of the termination section as the primary conductors, within 24 inches of the front of the cabinet.

## 5.4.2 Additional Requirements for Services Up to 12.47 kV

For services up to 12.47 kV, the termination section must meet the requirements defined in EUSERC 418, as well as those shown in [Figure 10](#) and the following:

1. The bus must have a minimum 6-inch phase-to-ground separation, including the cabinet.
2. The bus must have a minimum 7.5-inch phase-to-phase separation, edge-to-edge.

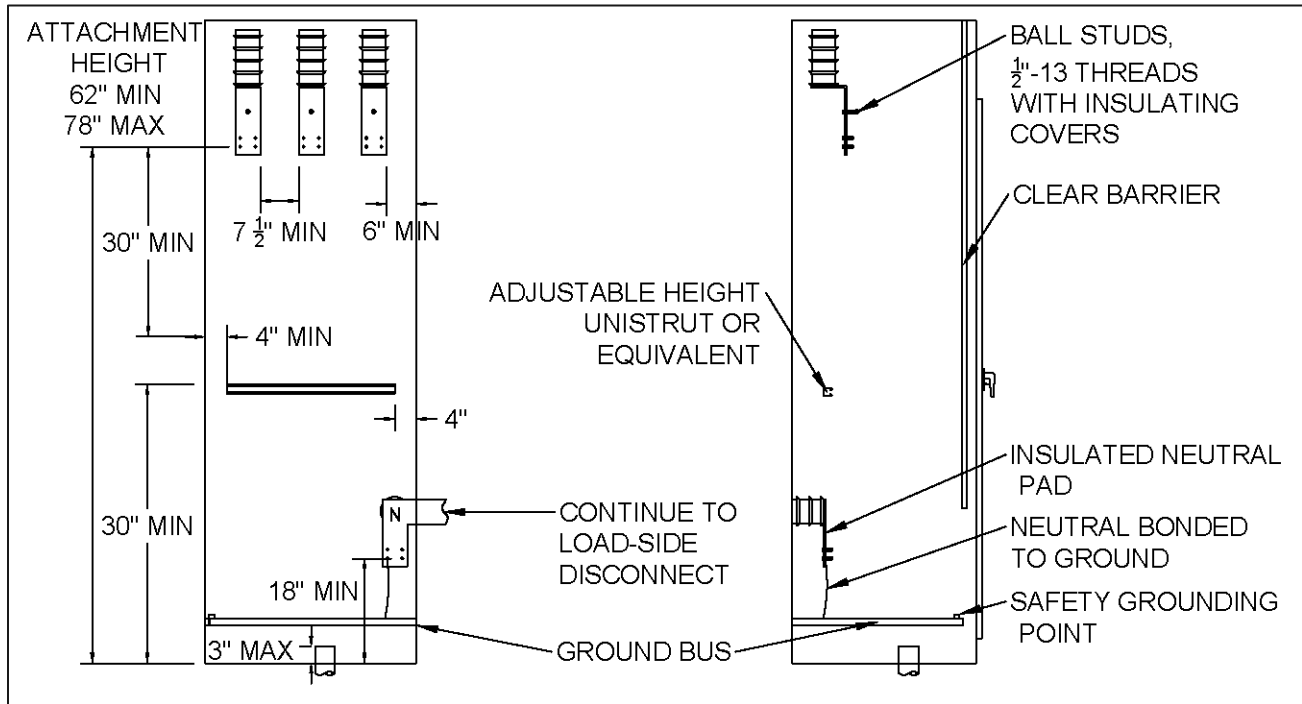

Figure 10: Termination Compartment Clearances for 12.47 kV (STD-M-3301)

### 5.4.3 Additional Requirements for 34.5 kV Services

For 34.5 kV services, the termination section must meet PGE's requirements, as shown in [Figure 11](#) and listed below.

1. The bus must have a minimum 10-inch phase-to-ground separation, including the cabinet.
2. The bus must have a minimum 15-inch phase-to-phase separation, edge-to-edge.
3. The bus must have a minimum 18-inch phase-to-phase separation, centerline-to-centerline.

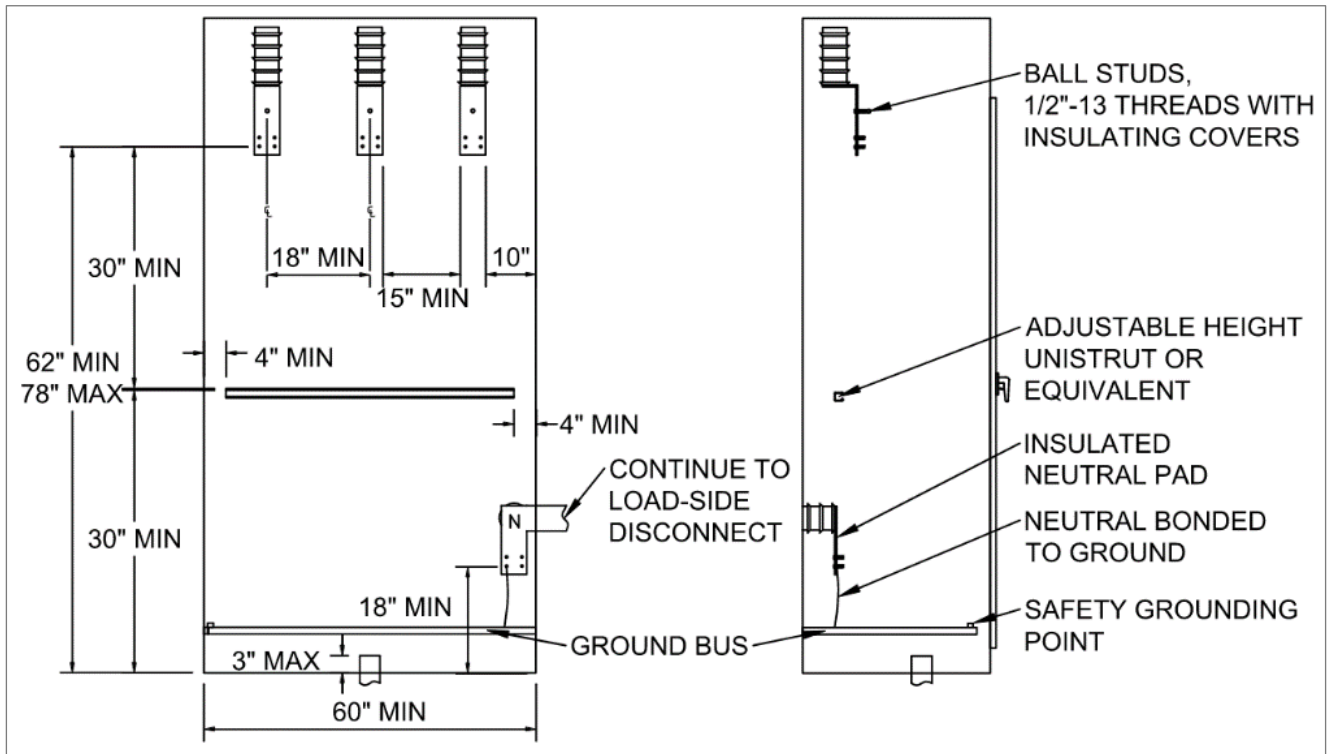

Figure 11: Termination Compartment Clearances for 34.5 kV (STD-M-3601)

## 5.5 CURRENT TRANSFORMER COMPARTMENT

For 12.47 kV and 34.5 kV services, the current transformer (CT) section must meet the following requirements:

1. The CT compartment must include provisions to mount three wound-type current transformers.
2. All bus work to connect the CTs must be installed by the enclosure manufacturer.
3. A minimum 1/4-inch clear polycarbonate insulating barrier is required between metering CTs and the access door. This barrier must be hinged to allow unobstructed access to the metering CTs and bus.
4. Configuration must allow PGE to ground the bus on both the load and source sides of the current transformer. The grounds must be 1/2-inch ball studs. These ball studs must be oriented toward the compartment opening and be supported to prevent movement during the installation and removal of grounds.

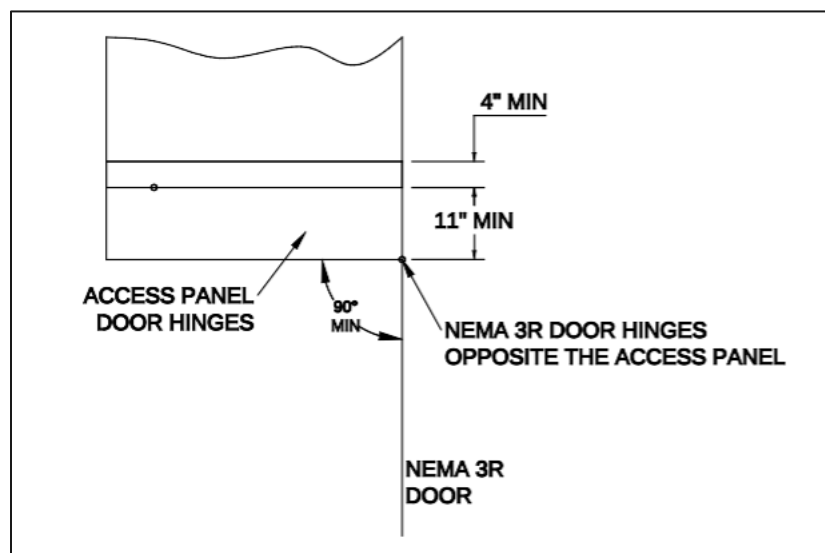

Figure 12: Access Panel Clearances (top view) for 12.47 kV and 34.5 kV (STD-M-3001)

For 12.47 kV services, the current transformer compartment must meet applicable clearances outlined in EUSERC 401, as shown in [Figure 12](#).

### 5.5.1 CT Mounting Base Plate and Bolt Patterns

The mounting pattern for the instrument transformers must meet the requirements of EUSERC 407. Refer to EUSERC Section 400 for requirements detail.

For 12.47kV services, CTs must be mounted vertically in-line with bus connections. CT mounting base plate must meet the requirements of EUSERC 407, as shown in [Figure 14](#).

The National Electrical Manufacturers Association (NEMA) bolt patterns at each CT end are based on service amperage and CT availability. Bolt patterns are shown in [Figure 15](#), and detailed in the following requirements:

1. For 12.47 kV services up to 600 A: NEMA 2-bolt pattern is required.
2. For 12.47 kV services between 601 A and 1200 A: NEMA 4-bolt pattern is required.
3. For 34.5 kV: NEMA 2-bolt pattern is required.

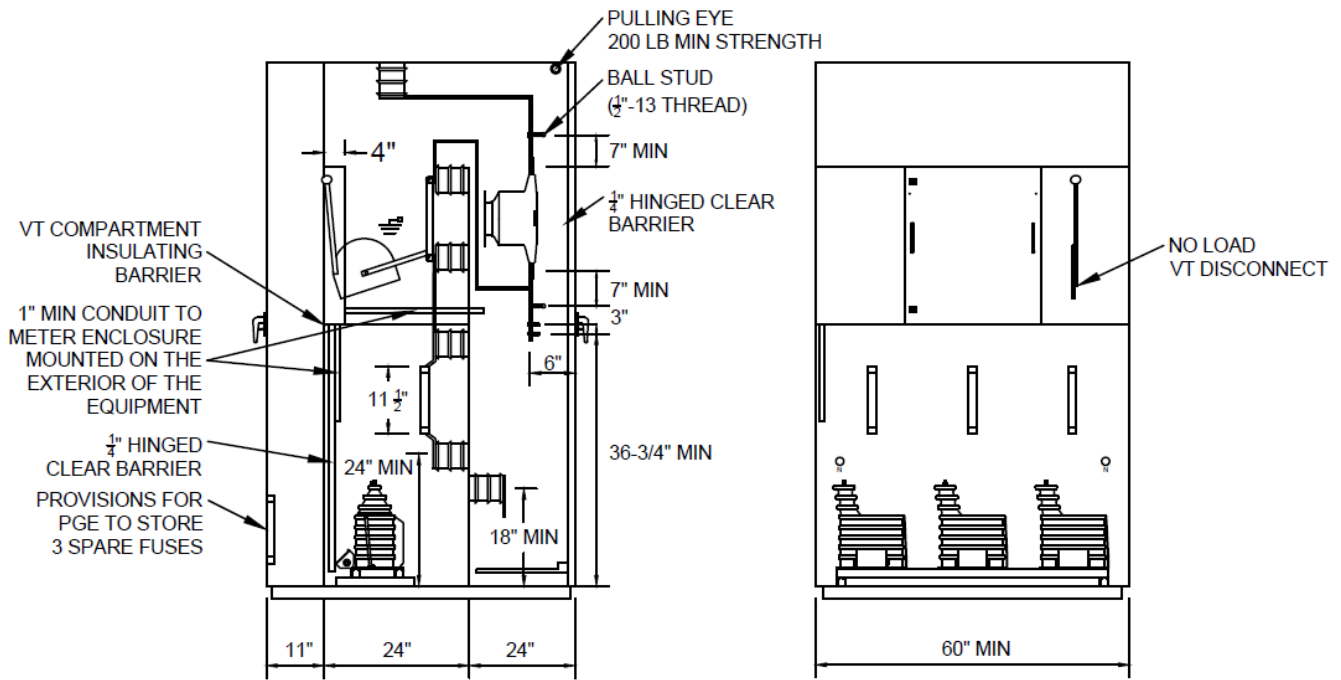

NOTE: IF CUSTOMERS USE A REMOTE METER ENCLOSURE, THEN 1 - 2" MIN CONDUIT IS REQUIRED.

Figure 13: CT and VT Clearances for 12.47 kV (STD-M-3300)

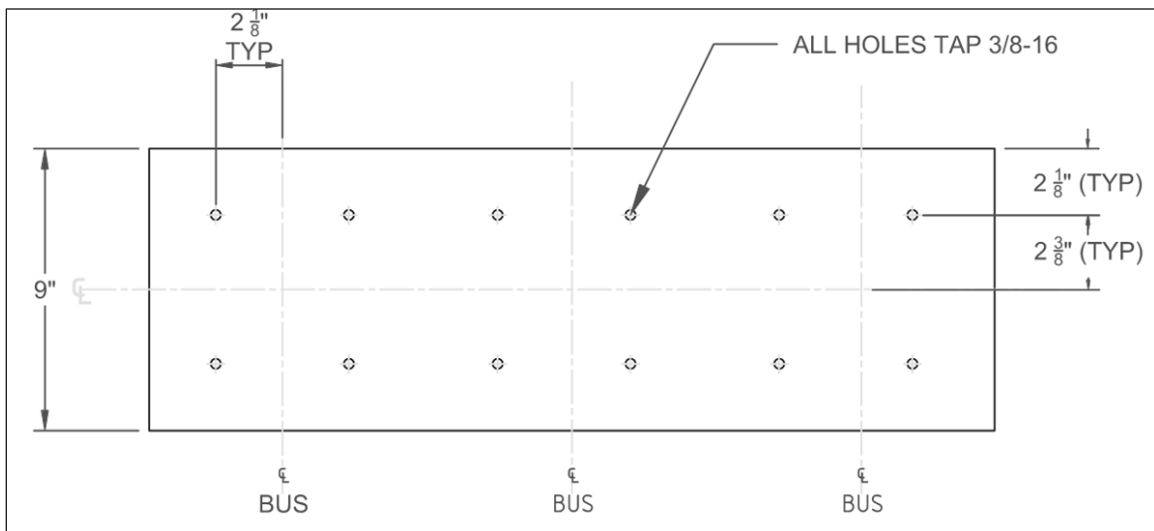

Figure 14: CT Mounting Plate for 12.47 kV (STD-M-3303)

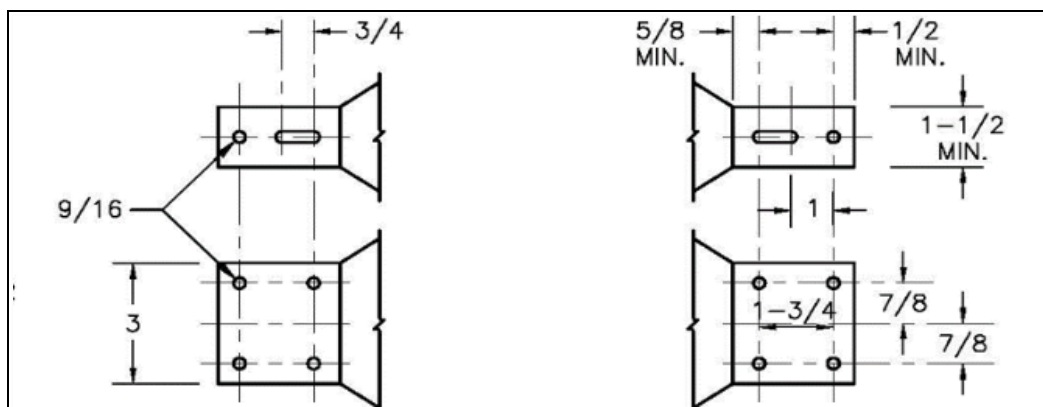

Figure 15: CT-Bolt Patterns for 12.47 kV – NEMA 2-hole (left), NEMA 4-hole (right)

For 34.5 kV services, the CT compartment must meet requirements shown in [Figure 16](#) and listed in the following paragraph.

CTs must be mounted on P1000 Unistrut (or equivalent) channel, mounted horizontally with bus connections located at the top. The CT mounting base plate must meet the requirements shown in [Figure 17](#).

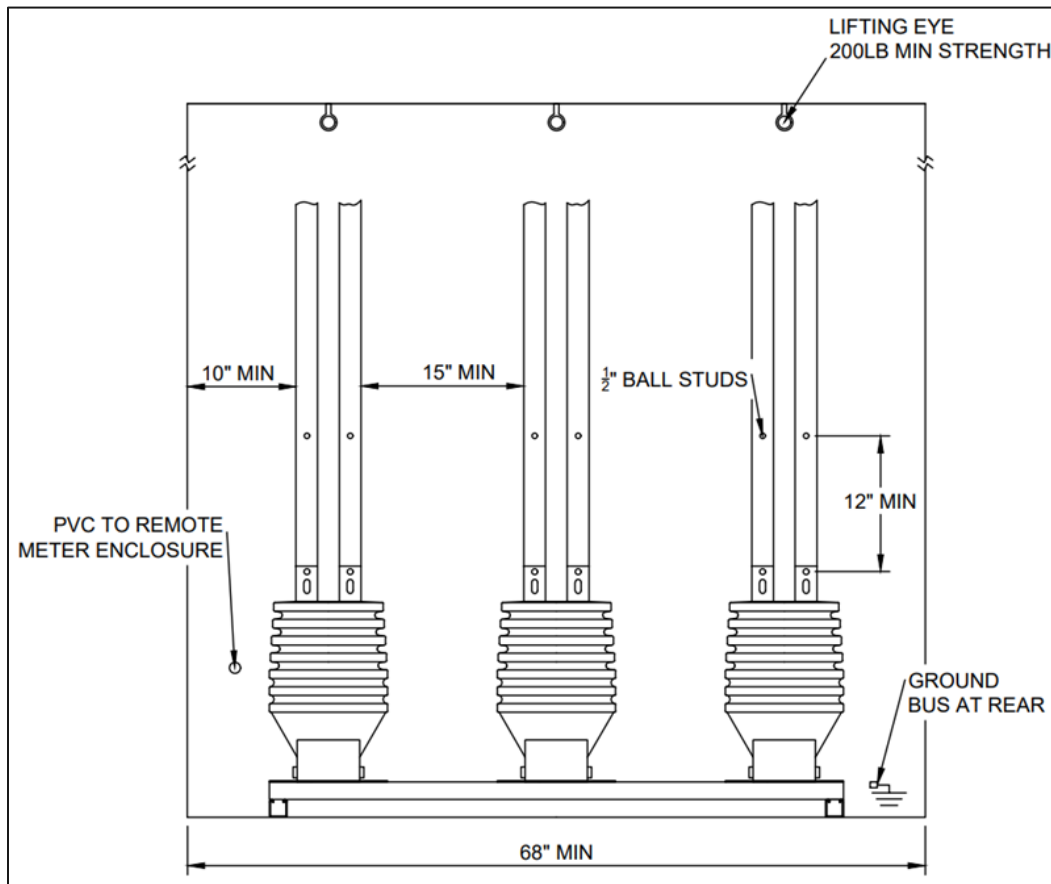

Figure 16: CT Clearances for 34.5 kV (STD-M-3602)

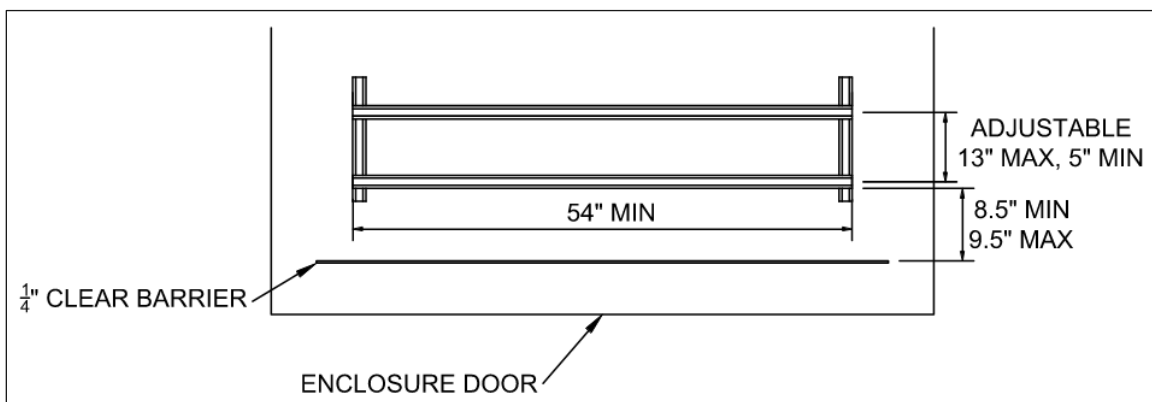

Figure 17: CT Mounting for 34.5 kV (STD-M-3603)



## 5.6 VOLTAGE TRANSFORMER COMPARTMENT

For 12.47 kV and 34.5 kV services, the voltage transformer (VT) section must meet the following requirements:

1. The VT compartment must include provision to mount three wound-type VTs.
2. All bus work to connect the VTs must be installed by the enclosure manufacturer.
3. Insulated barriers must be installed to fully isolate the VT compartment from any energized bus or other energized devices when the VT disconnect switch is in the open position.
4. Kirk® key interlocks must be installed on the VT disconnect, the fuse compartment, and the VT compartment doors.
5. VTs must be mounted on P1000 Unistrut channel (or equivalent). VTs must be mounted horizontally with bus connections located at the top.
6. VT mounting base spacing must meet the requirements of EUSERC 407, as shown in [Figure 18](#).

For 12.47 kV services, the VT compartment must meet the clearances shown in [Figure 18](#).

For 34.5 kV services, the VT compartment must meet the clearances shown in [Figure 19](#).

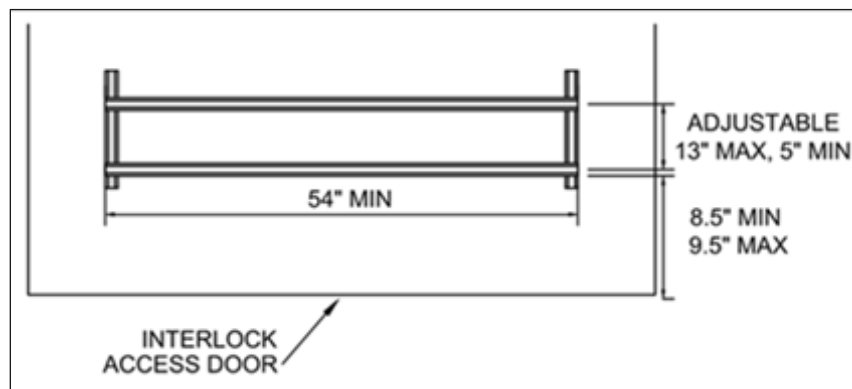

Figure 18: VT Mounting for 12.47 kV and 34.5 kV (STD-M-3003)

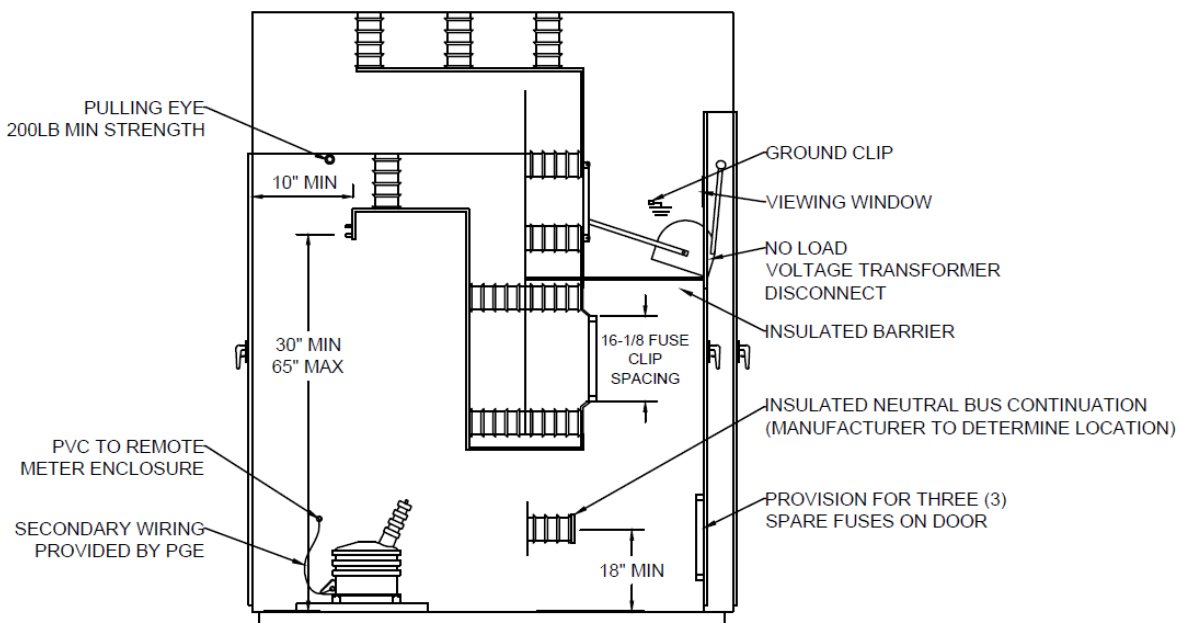

Figure 19: VT Compartment for 34.5 kV (STD-M-3600)

---

### 5.6.1 Voltage Transformer Disconnect

The voltage transformer (VT) compartment must include a three-phase, gang-operated, blade-and-jaw type voltage transformer disconnect for de-energizing voltage transformers. Wiping contacts or pressure contacts are not acceptable.

The VT disconnect switch must provide a visual open, and it must have two positions: closed and open/ground. In the fully open/ground position, the switch must provide a visible air gap to verify disconnect, and the disconnect blades must visibly and automatically ground.

Both positions of the VT disconnect switch must be visible through the viewing window in the compartment door; the viewing window must be placed directly in front of the switch. The window should be located no higher than 8 feet above ground level. All other viewing windows for PGE controlled cabinets and equipment are prohibited. PGE also discourages line-side viewing windows.

The VT disconnect switch is not required to be rated for loadbreak operation.

The operating handle or lever of the VT disconnect switch must be lockable in the closed position with a standard padlock (5/16-inch shaft).

The Kirk® key interlock system must prevent the disconnect switch from closing unless the VT compartment door is closed and locked, as described in EUSERC 400, III. A.

The customer must supply PGE with two keys to the interlock system. PGE will install a lock box on the compartment door for key storage.

### 5.7 FUSE COMPARTMENT

For 12.47kV and 34.5kV services, the fuse compartment must include provisions for three fuse holders for mounting indoor-type current-limiting fuses to provide protection for VTs.

Storage for at least three spare fuses must be provided on the inside of the fuse compartment door.

The jumpers from the fuses to the voltage transformers will be installed by PGE.

For 12.47 kV services, each fuse holder provided must have two mounting clips with spacing of 11 1/2-inches, measured from clip centers, and each must accept a fuse ferrule diameter of 1 5/8-inches. The fuse terminal connection must have NEMA 2-hole spacing.

Fuses must have a 15 kV voltage rating with a minimum ampere rating of 0.5 A and maximum of 1 A. Acceptable fuse options include (but are not limited to) the following:

1. Eaton Bussmann CAV, Catalog # 15.5CAVH0.5E
2. Eaton Bussmann CAV, Catalog # 15.5CAVH1E

For 34.5 kV services, each fuse holder must have two mounting clips with spacing of 16 1/8-inches measured from clip centers, and each must accept a fuse ferrule diameter of 1 3/5-inches. The fuse terminal connection must have NEMA 2-hole spacing.

Fuses must have a 38 kV voltage rating with a minimum ampere rating of 0.5 A and maximum of 1 A.

Acceptable fuse options include the following:

3. Eaton Bussmann CAV, Catalog # 38CAVH0.5E
4. Eaton Bussmann CAV, Catalog # 38CAVH1E

---

## 5.8 REMOTE METERING ENCLOSURE

PGE's standard for medium-voltage services is to meter customers with an outdoor customer-owned metering enclosure, with the meter attached to the exterior of the enclosure to ensure adequate communication. Alternately, customers can choose to provide a 5-foot by 5-foot space within 50 feet of the switchboard for a remote meter enclosure. Remote meter enclosure requirements can also be found in [ESR](#) Sections 10.7.4, 10.7.5, and 11.3.10. Consult with PGE for additional remote meter enclosure requirements.

PGE may approve indoor metering equipment if—in PGE's opinion—a suitable outdoor location does not exist. For minimum requirements for indoor metering equipment, refer to [Section 1.9, Meter Equipment](#) and [Section 3, Access and Clearance Requirements](#).

The meter socket must meet these requirements:

1. It must be ANSI Form 9S.
2. It must be compatible with a 13-terminal, 4-wire socket-type meter.
3. It must be designed for back connection.
4. The secondary test switch must have a lockable cover.
5. It must meet EUSERC 339.

### 5.8.1 Additional Metering Requirements

If a customer is participating in PGE's Dispatchable Standby Generation (DSG) program or is a Qualified Facility (QF) greater than 3 MW, the metering compartment must be furnished with the following:

1. One 15 A, 120 VAC receptacle must be provided by the customer and installed within 3 feet of the remote meter enclosure.
2. The receptacle must be fed by an alternate power source (not the source powering the switchboard).

Refer to [Section 7.4, Dispatchable Standby Generation or QF Greater than 3MW](#), for additional requirements.

### 5.8.2 Access Panel Requirements

Due to use of a remote meter enclosure, the meter panel becomes a general access panel. The access panel must be hinged on the side opposite the outer door. The panel must open to at least 90 degrees and be able to lock in the open position at least 90 degrees. The meter panel must meet requirements shown in [Figure 20](#).

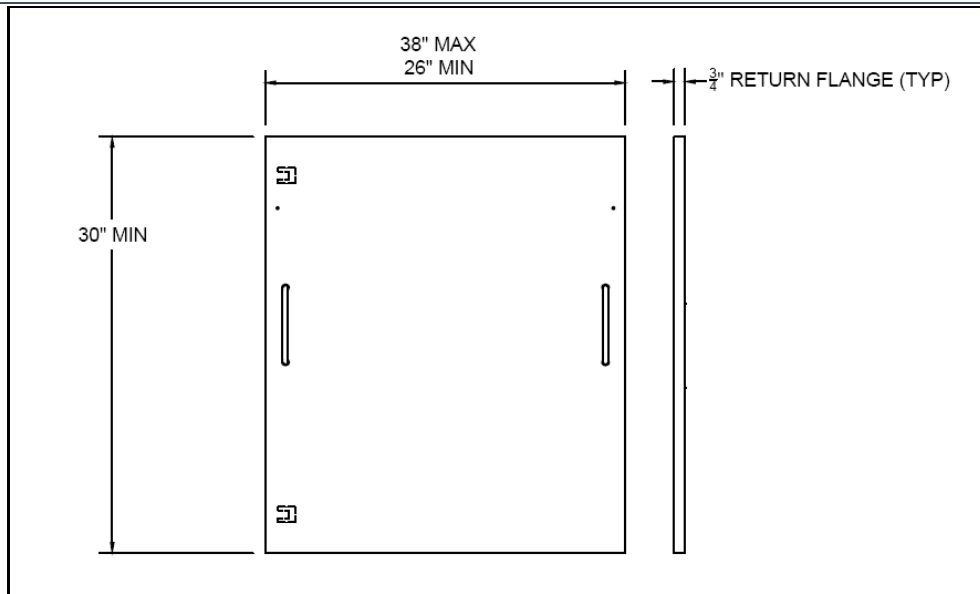

Figure 20: Access Panel Clearances (front view) for 12.47 kV and 34.5 kV (STD-M-3002)

## 5.9 LOAD-SIDE DISCONNECT REQUIREMENTS

For load-side disconnect requirements, refer to [Section 1.6, Load-Side Point of Isolation](#).

## 5.10 GROUNDING SWITCHES IN CUSTOMER SECTION(S)

If the customer's system includes any grounding switches, the switches must be interlocked with the load-side disconnect such that once the disconnect is open, it cannot be closed until the ground switch is closed. This is to prevent grounding an energized PGE feeder or the energizing of the customer's system while grounded.

---

## 6 Instrument Transformer Requirements

### TOPICS IN THIS SECTION

- General Instrument Transformer Requirements
- Current Transformer for Utility Metering
- Voltage Transformer for Utility Metering

### 6.1 GENERAL INSTRUMENT TRANSFORMER REQUIREMENTS

#### 6.1.1 Test Switches

PGE uses test switches when metering requires instrument transformers. The 10-terminal test switch shown in [Figure 21](#) is for three-phase applications. PGE provides this test switch.

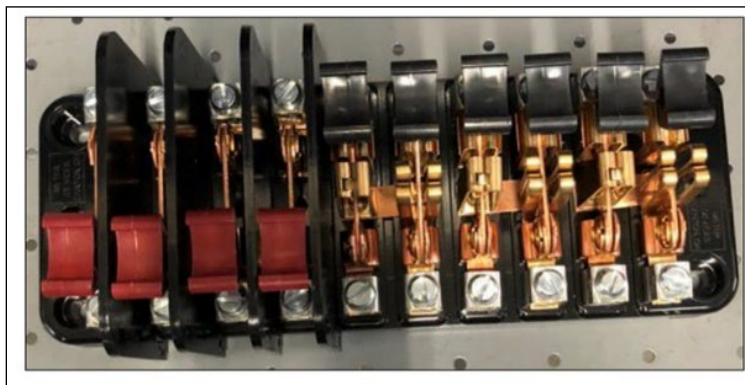

Figure 21: 10-Terminal Test Switch

#### 6.1.2 Grounding Switches

Grounding and bonding are critical for safety and electrical reliability. PGE requires all medium-voltage services to meet grounding, fault current, and arc flash requirements. The customer is responsible for ensuring that the electrical wiring and service equipment is grounded and bonded in accordance with applicable NESC, local ordinances, and PGE standards. The neutral-ground bond requirements are detailed in the [Medium-Voltage Example Drawing Package](#) document on [PortlandGeneral.com/ESR](http://PortlandGeneral.com/ESR).

**IMPORTANT:** If the customer's system includes any grounding switches, the switches must be interlocked to prevent grounding an energized PGE feeder or energizing the customer's system while grounded. Interlock must be located between the load-side disconnect and downstream customer ground switch.

### 6.2 CURRENT TRANSFORMER FOR UTILITY METERING

Current transformers must be minimum IEEE C57.13 0.15 accuracy class.

1. For 12.47 kV services, CTs must be indoor wound-type.
2. For 34.5 kV services, CTs must be outdoor wound-type.

CT selection is based on nominal ratio and rating factor (RF) at 30°C according to anticipated customer loading.

---

PGE provides current transformers for utility metering.

### **6.3 VOLTAGE TRANSFORMER FOR UTILITY METERING**

Voltage transformers must be minimum 0.3 accuracy class at burden Y.

1. For 12.47 kV services, VTs will be indoor wound-type with provision for no fuses.
2. For 34.5 kV services, VTs will be outdoor wound-type with provision for no fuses.

All bus work to connect the voltage transformers, the VT disconnect, and the fuses must be installed by the enclosure manufacturer.

PGE provides voltage transformers for utility metering.

---

## 7 Customer Generation

### TOPICS IN THIS SECTION

- General Information
- Disconnect Switch Requirements
- Emergency or Standby Generator
- Dispatchable Standby Generation

### 7.1 GENERAL INFORMATION

As discussed in this section, customer generation includes generators, solar, wind, and other qualifying resources.

**IMPORTANT:** Before installing any generation equipment, customers must apply with PGE's Customer Interconnections group or Dispatchable Standby Generation team for review, approval, and interconnection of proposed generation. PGE will not review customer's medium-voltage switchboards until the customer interconnection process is underway. Additional information and requirements are available in the Distribution Interconnection Handbook.

All sites with customer generation require a label on the utility section that reads: "Warning: Customer Owned Generation. Two sources may be present."

### 7.2 DISCONNECT SWITCH REQUIREMENTS

When customer-owned equipment is required to have a disconnect, the following criteria apply:

1. The switch should be located within 10 feet of the PGE meter and in direct line of sight. If PGE approves a variance allowing the disconnect switch to be placed more than 10 feet from the bidirectional meter or not in line of sight, an engraved phenolic map of the site must be placed above the PGE meter. This map must show the locations of both the meter and the location of the disconnect.
2. The disconnect switch must be accessible 24 hours a day. Any hindrance (including siding, caulking, enclosures, and landscaping) must be removed by the property owner to allow PGE unrestricted access. Fences must have an unlocked gate or a PGE-approved lock that allows unrestricted PGE access.
3. Services with the potential for bidirectional flow, which includes all distributed energy resources (DER) services, must have a line-side disconnect within the gear. If an upstream point of isolation is not within 30 feet, then a line-side disconnect switch is required.

**IMPORTANT:** PGE highly recommends that customers install this proactively, even if no DERs are planned when the service is being designed.

Local jurisdictions may require additional modes of disconnection.

### 7.3 EMERGENCY OR STANDBY GENERATOR

Any permanently installed emergency or standby generator must be connected to the customer's wiring system using a permanently installed, open-transition ("break-before-make") transfer switch intended for

that purpose. Failure to use such a switch can produce a hazardous situation for PGE workers or other service personnel.

Closed transition ("make-before-break") may be allowed at PGE's discretion, and PGE's permission is required before the customer procures such equipment.

## 7.4 DISPATCHABLE STANDBY GENERATION OR QF GREATER THAN 3MW

If a customer is participating in PGE's Dispatchable Standby Generation (DSG) program or is a Qualified Facility (QF) greater than 3MW, the customer must provide a remote meter enclosure with additional provisions for an ethernet connection from the meter to the customer's local telecommunications point of presence. The customer is responsible for meeting PGE's DSG communication requirements for real-time monitoring. DSG metering requirements are shown in [Figure 22](#).

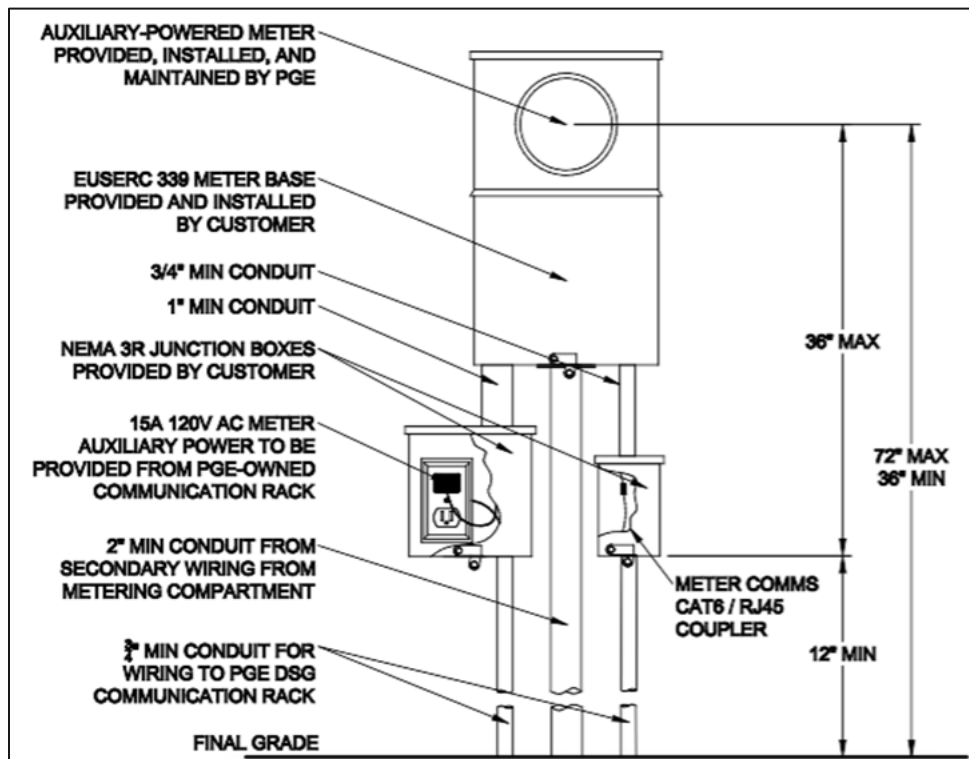

Figure 22: Remote Meter Configuration Used for DSG (STD-M-4001)



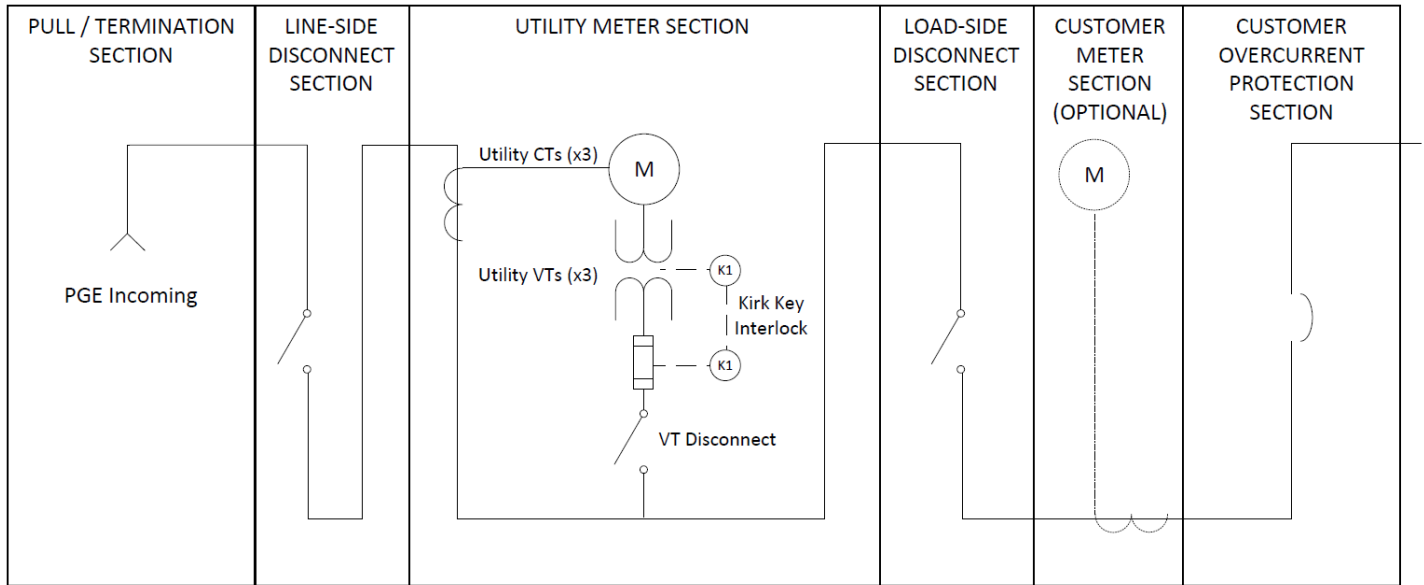
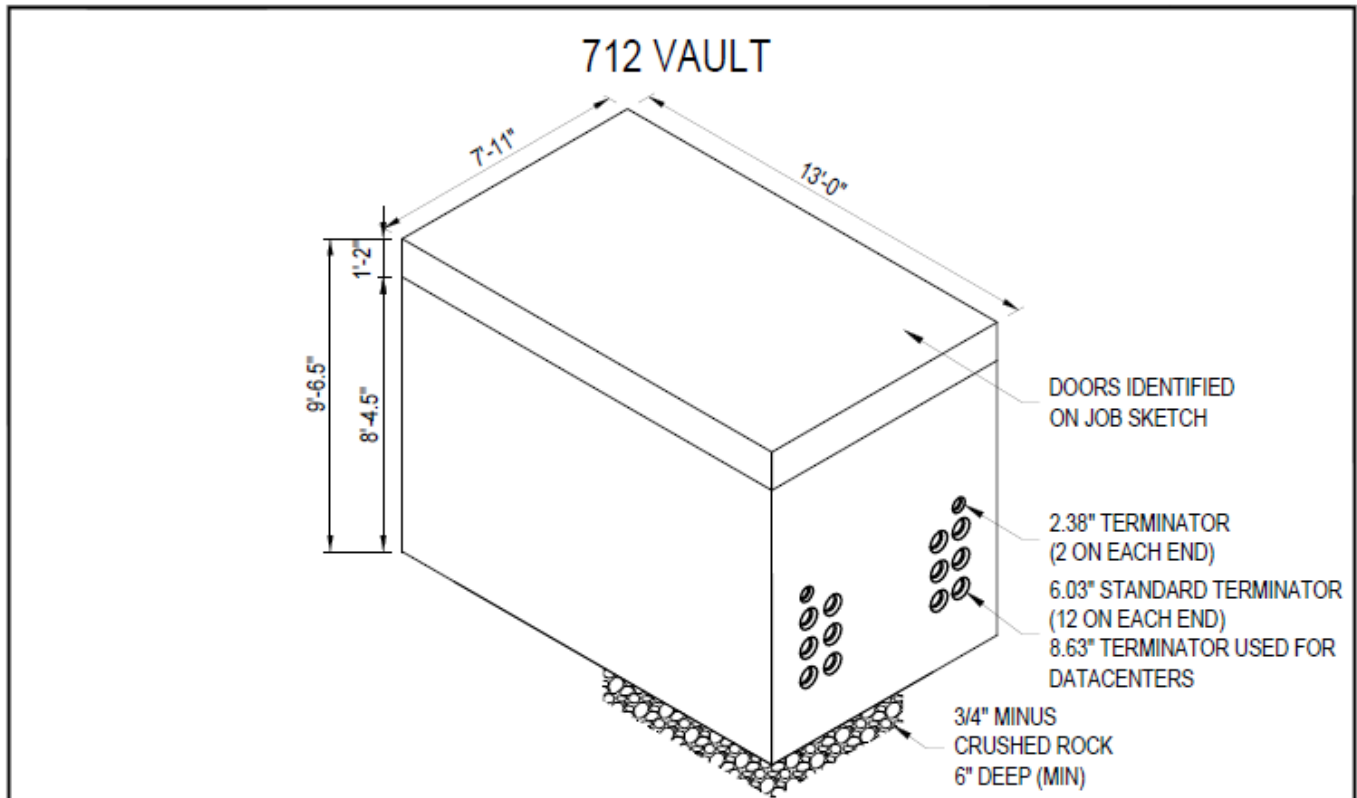

Figure 23: DSG Compartment Layout and Electrical One-Line

# Appendix A Generic Vault and Switch Dimensions



## REQUIRED WORKING CLEARANCES

FLAT, CLEAR, UNOBSTRUCTED AREAS WITH NO SHRUBS, TREES, AWNINGS, DECKS, BALCONIES, OR OTHER OBSTRUCTIONS.

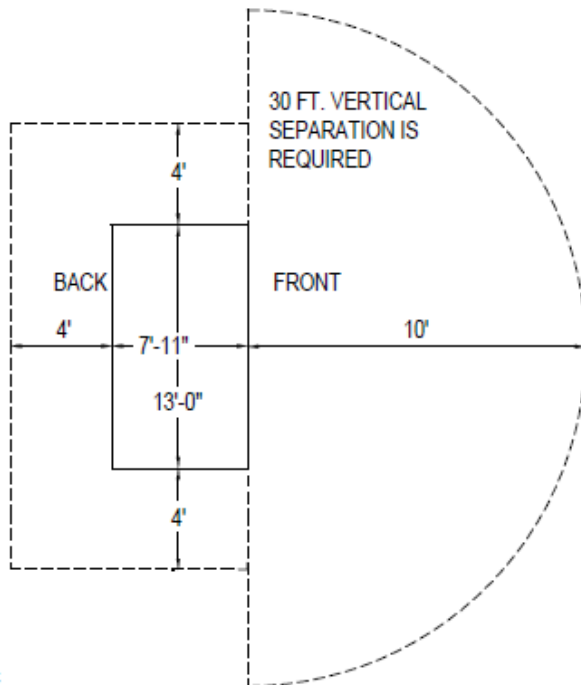

### NOTES:

1. PGE WILL SELECT THE LOCATION, TYPE AND NUMBER OF VAULT(S) AS WELL AS THE ORIENTATION OF THE EQUIPMENT. TYPICALLY THE OPENING MUST FACE THE STREET SIDE OR A PARKING AREA.
2. CUSTOMER IS RESPONSIBLE FOR ALL TRENCH, CONDUIT, VAULTS, PADS AND ROAD CROSSINGS. ALL CONDUIT TO BE INSTALLED AT DEPTHS REQUIRED TO ENTER PADS, VAULTS, AND EQUIPMENT AS DETERMINED BY PGE. PGE'S MIN COVER IS 30 INCHES FROM TOP OF CONDUIT TO FINAL GRADE. MOST CONDUIT PACKAGES REQUIRE ADDITIONAL COVER SO THAT THE CONDUIT IS LEVEL AND STRAIGHT FOR A MINIMUM 3' FOR CONDUITS 6" OR SMALLER, OR 10' FOR 8" CONDUIT, WHEN ENTERING THE KNOCKOUTS (TERM-A-DUCTS) OF THE VAULT. CONDUITS SHOULD NOT CROSS BETWEEN VAULTS.
3. PGE TO DETERMINE THE SIZE AND NUMBER OF CONDUITS REQUIRED. ALL PGE CONDUCTORS TO BE INSTALLED IN GRAY, SCHEDULE 40, ELECTRICAL GRADE PVC CONDUIT WITH 2,500 LB RATED WOVEN POLYESTER PULL TAPE (SUCH AS MULE TAPE OR HERCULINE) PULLED INTO THE CONDUIT. MAINTAIN 12" VERTICAL AND 24" HORIZONTAL CLEARANCE BETWEEN GAS AND OTHER UTILITIES. ALL CONDUIT SWEEPS MUST BE FACTORY MADE. ALL CONDUIT SWEEPS 4" & SMALLER TO BE 36" RADIUS. ALL CONDUIT SWEEPS 5-6" TO BE 60" RADIUS. ALL CONDUIT SWEEPS 8" TO BE A MINIMUM OF 84" RADIUS AND MUST BE MADE OF FIBERGLASS OR RIGID STEEL. FIBERGLASS OR RIGID STEEL SWEEPS ARE ALSO REQUIRED FOR RUNS OF 151' OR LONGER, OR FOR ANY LENGTH RUN WITH MORE THAN 180 DEGREES IN BENDS. THE MAXIMUM TOTAL BENDS IN ANY CONDUIT RUN IS 270 DEG.
4. PGE EQUIPMENT MUST BE WITHIN 15 FEET OF A DRIVABLE AREA. BARRIERS ARE REQUIRED AROUND EQUIPMENT EXPOSED TO VEHICLES.
5. REFER TO PGE'S MEDIUM VOLTAGE BOOK FOR FURTHER CLEARANCES AND REQUIREMENTS, [www.portlandgeneral.com/esr](http://www.portlandgeneral.com/esr).

CONTRACTOR LEVEL: LEVEL 2 TYPICALLY

PAGE SET-UP: DWG TO PDF (PLOT) AND FULL BLEED (A, B, 90X 11.00 INCHES)

STD-D-3356.DWG | 5/20/2024 7:23:28 AM | MARIE MENDEZ-NUÑEZ

Public  
Access Not Limited

**PGE**  
PORTLAND GENERAL  
ELECTRIC CO.  
121 SW SALMON ST.  
PORTLAND, OR 97204

TYPICAL COMMERCIAL PGE PADS AND VAULTS  
712 - 8" SPLICE VAULT WITH LIFTOUTS

DOCUMENTS REFERENCED: MEDIUM VOLTAGE GUIDE, 12/01/15-712

DEPARTMENT: STANDARDS

BUSINESS PARTNER:  
DESIGNERS, CPWA, PCCA

**WARNING**  
IF THIS DRAWING IS USED FOR CONSTRUCTION, THE USER SHALL BE RESPONSIBLE FOR VERIFYING ALL DIMENSIONS AND REQUIREMENTS.

DATE: 5/20/2024  
DRAWN BY: MLJM  
SCALE: NOT TO SCALE

DRAWING NO.:  
**STD-D-3356**

# 816 PGE SWITCH VAULT

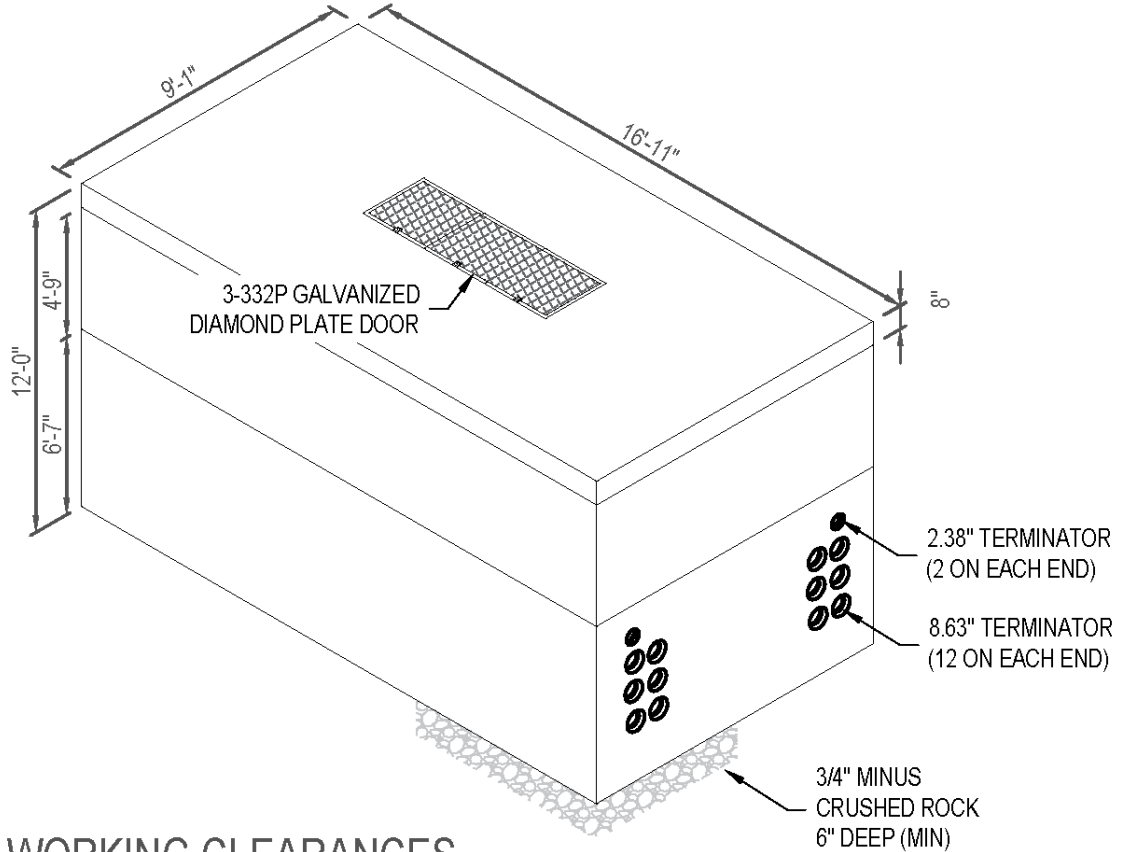

## REQUIRED WORKING CLEARANCES

FLAT, CLEAR, UNOBSTRUCTED AREAS WITH NO SHRUBS, TREES, AWNINGS, DECKS, BALCONIES, OR OTHER OBSTRUCTIONS.

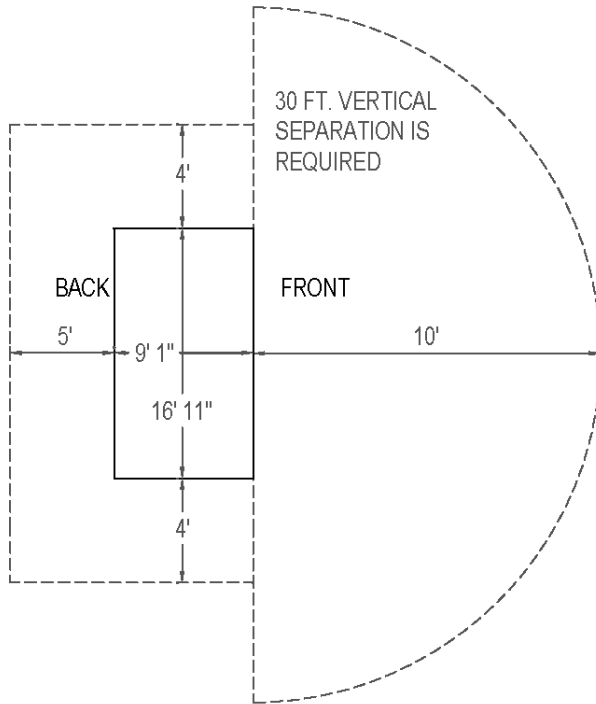

### NOTES:

1. PGE WILL SELECT THE LOCATION, TYPE AND NUMBER OF VAULT(S)/TRANSFORMERS, AS WELL AS THE ORIENTATION OF THE EQUIPMENT. TYPICALLY THE OPENING MUST FACE THE STREET SIDE OR A PARKING AREA.
2. CUSTOMER IS RESPONSIBLE FOR ALL TRENCH, CONDUIT, VAULTS, PADS AND ROAD CROSSINGS. ALL CONDUIT TO BE INSTALLED AT DEPTHS REQUIRED TO ENTER PADS, VAULTS, AND EQUIPMENT AS DETERMINED BY PGE. PGE'S MIN COVER IS 30 INCHES FROM TOP OF CONDUIT TO FINAL GRADE. MOST PAD MOUNT TRANSFORMERS AND VAULTS REQUIRE ADDITIONAL COVER SO THAT THE CONDUIT IS LEVEL AND STRAIGHT FOR A MINIMUM 3' WHEN ENTERING THE LOWER KNOCKOUTS (TERM-A-DUCTS). PVC SHOULD NOT CROSS BETWEEN VAULTS.
3. PGE TO DETERMINE THE SIZE AND NUMBER OF CONDUITS REQUIRED. ALL PGE CONDUCTORS TO BE INSTALLED IN GRAY, SCHEDULE 40, ELECTRICAL GRADE PVC CONDUIT WITH 2,500 LB RATED WOVEN POLYESTER PULL TAPE (SUCH AS MULE TAPE OR HERCULINE) PULLED INTO THE CONDUIT. MAINTAIN 12" VERTICAL AND 24" HORIZONTAL CLEARANCE BETWEEN GAS AND OTHER UTILITIES. ALL CONDUIT SWEEPS MUST BE FACTORY MADE. ALL CONDUIT SWEEPS 4" & SMALLER TO BE 36" RADIUS. ALL CONDUIT SWEEPS 5-6" TO BE 60" RADIUS. ALL CONDUIT SWEEPS 8" TO BE A MINIMUM OF 84" RADIUS AND MUST BE MADE OF FIBERGLASS OR RIGID STEEL. FIBERGLASS OR RIGID STEEL SWEEPS ARE ALSO REQUIRED FOR RUNS OF 151' OR LONGER, OR FOR ANY LENGTH RUN WITH MORE THAN 180 DEGREES IN BENDS. THE MAXIMUM TOTAL BENDS IN ANY CONDUIT RUN IS 270 DEG.
4. PGE EQUIPMENT MUST BE WITHIN 15 FEET OF A DRIVABLE AREA. BARRIERS ARE REQUIRED AROUND EQUIPMENT EXPOSED TO VEHICLES.
5. REFER TO PGE'S MEDIUM VOLTAGE BOOK FOR FURTHER CLEARANCES AND REQUIREMENTS, [www.portlandgeneral.com/esr](http://www.portlandgeneral.com/esr).

CONTRACTOR LEVEL: LEVEL 3.

Public

Access Not Limited



PORTLAND GENERAL  
ELECTRIC CO.  
121 SW SALMON ST.  
PORTLAND, OR 97204

TYPICAL COMMERCIAL PGE PADS AND VAULTS  
816 PGE SWITCH VAULT W/ 3-332P

DOCUMENTS: MEDIUM VOLTAGE GUIDE  
CROSS REFERENCED:



DATE: 02/03/2023  
DRAWN BY: MLMM  
SCALE: NOT TO SCALE

DEPARTMENT: STANDARDS

BUSINESS PARTNER:  
DESIGNERS, DPMs, FCCS

DRAWING NO.:

STD-D-3350

PAGE SETUP: DWG TO PDF (ANSI) EXPAND A (8.5 X 11.0) INCHES

STD-D-3350.DWG 15/03/2023 10:15:56 AM | MARIE MENDEZ-NUNEZ

# 816-PADMOUNT VISTA SWITCH

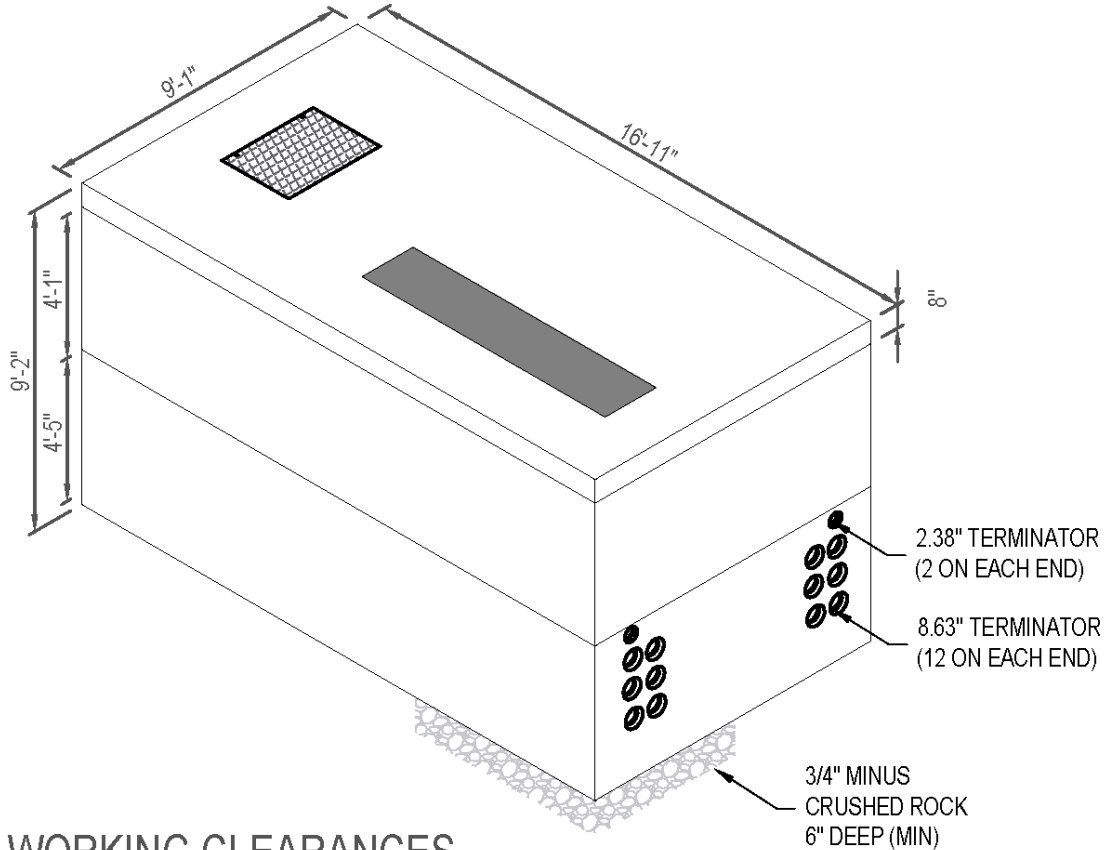

## REQUIRED WORKING CLEARANCES

FLAT, CLEAR, UNOBSTRUCTED AREAS WITH NO SHRUBS, TREES, AWNINGS, DECKS, BALCONIES, OR OTHER OBSTRUCTIONS.

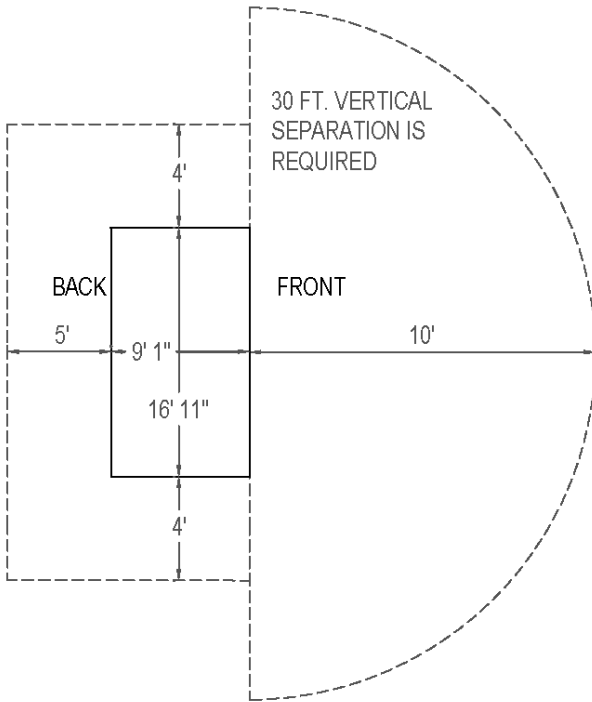

### NOTES:

1. PGE WILL SELECT THE LOCATION, TYPE AND NUMBER OF VAULT(S)/TRANSFORMERS, AS WELL AS THE ORIENTATION OF THE EQUIPMENT. TYPICALLY THE OPENING MUST FACE THE STREET SIDE OR A PARKING AREA.
2. CUSTOMER IS RESPONSIBLE FOR ALL TRENCH, CONDUIT, VAULTS, PADS AND ROAD CROSSINGS. ALL CONDUIT TO BE INSTALLED AT DEPTHS REQUIRED TO ENTER PADS, VAULTS, AND EQUIPMENT AS DETERMINED BY PGE. PGE'S MIN COVER IS 30 INCHES FROM TOP OF CONDUIT TO FINAL GRADE. MOST PAD MOUNT TRANSFORMERS AND VAULTS REQUIRE ADDITIONAL COVER SO THAT THE CONDUIT IS LEVEL AND STRAIGHT FOR A MINIMUM 3' WHEN ENTERING THE LOWER KNOCKOUTS (TERM-A-DUCTS). PVC SHOULD NOT CROSS BETWEEN VAULTS.
3. PGE TO DETERMINE THE SIZE AND NUMBER OF CONDUITS REQUIRED. ALL PGE CONDUCTORS TO BE INSTALLED IN GRAY, SCHEDULE 40, ELECTRICAL GRADE PVC CONDUIT WITH 2,500 LB RATED WOVEN POLYESTER PULL TAPE (SUCH AS MULE TAPE OR HERCULINE) PULLED INTO THE CONDUIT. MAINTAIN 12" VERTICAL AND 24" HORIZONTAL CLEARANCE BETWEEN GAS AND OTHER UTILITIES. ALL CONDUIT SWEEPS MUST BE FACTORY MADE. ALL CONDUIT SWEEPS 4" & SMALLER TO BE 36" RADIUS. ALL CONDUIT SWEEPS 5-6" TO BE 60" RADIUS. ALL CONDUIT SWEEPS 8" TO BE A MINIMUM OF 84" RADIUS AND MUST BE MADE OF FIBERGLASS OR RIGID STEEL. FIBERGLASS OR RIGID STEEL SWEEPS ARE ALSO REQUIRED FOR RUNS OF 151' OR LONGER, OR FOR ANY LENGTH RUN WITH MORE THAN 180 DEGREES IN BENDS. THE MAXIMUM TOTAL BENDS IN ANY CONDUIT RUN IS 270 DEG.
4. PGE EQUIPMENT MUST BE WITHIN 15 FEET OF A DRIVABLE AREA. BARRIERS ARE REQUIRED AROUND EQUIPMENT EXPOSED TO VEHICLES.
5. REFER TO PGE'S MEDIUM VOLTAGE BOOK FOR FURTHER CLEARANCES AND REQUIREMENTS, [www.portlandgeneral.com/esr](http://www.portlandgeneral.com/esr).

CONTRACTOR LEVEL: LEVEL 3.

Public

Access Not Limited



PORTLAND GENERAL  
ELECTRIC CO.  
121 SW SALMON ST.  
PORTLAND, OR 97204

TYPICAL COMMERCIAL PGE PADS AND VAULTS  
816-PADMOUNT VISTA SWITCH

DOCUMENTS MEDIUM VOLTAGE GUIDE  
CROSS REFERENCED:



DATE: 02/03/2023

DRAWN BY: MLMN

SCALE: NOT TO SCALE

DEPARTMENT: STANDARDS

BUSINESS PARTNER:  
DESIGNERS, DPMs, FCCs

DRAWING NO.:

STD-D-3351

PAGE SETUP: DWG TO PDF (PC3) ANSI (EXPAND A) (8.50 X 11.00) INCHES

STD-D-3351.DWG 1/5/2023 10:16:18 AM IMARIE MENDEZ-NUNEZ

## Appendix B Primary Meter Gear Inspection Checklists

PGE will use the following checklists (or updated versions) when inspecting medium-voltage gear.

1. [Primary Gear Pre-Inspection Checklist](#)
2. [Primary Gear Final Inspection Checklist](#)



Additional site-specific items may exist.

### B.1 PRIMARY GEAR PRE-INSPECTION CHECKLIST

To be completed by a PGE Service Inspector and/or Meterman after the customer has set in place and installed the medium-voltage switchboard, but before they have installed their own equipment inside the compartments.

**IMPORTANT:** Relay settings must be submitted to PGE Protection Engineering for review no later than 16 weeks prior to energization.

<input type="checkbox"/>	Gear is same as what was reviewed and accepted by Meter Engineering	
<input type="checkbox"/>	Verify clearances <ol style="list-style-type: none"> <li>1. Gear is located a minimum of 5 feet and a maximum of 15 feet from a 12-foot-wide paved road or compacted-gravel drivable surface that allows for unrestricted access</li> <li>2. Concrete pad required for outdoor gear with 60 inches of concrete in front of the cabinet</li> <li>3. Minimum 60 inches of clear workspace required in front of all sections</li> <li>4. Minimum 10 feet of clear workspace required in front of pull section</li> </ol> Additional clearance requirements exist for interior installations - refer to <a href="#">PGE Electric Service Requirements Book</a> , Section 13, "Electrical Equipment Rooms and Interior Installations."	
<input type="checkbox"/>	Gear is correct for the voltage rating and amp rating, and rating is listed on the name plate <p><b>NOTE:</b> If planned load is lower than available amperage, ensure that a placard showing current load is in place</p>	

<input type="checkbox"/>	Doors and barriers properly latch, hinge, and lock open at 90 degrees	
<input type="checkbox"/>	Provision for PGE padlock; no Kirk® key locks on the cabinet doors. A Kirk® key lock should be on VT disconnect handle (to operate disconnect) and the VT compartment panel.	

Compartment doors are labeled with placards and phenolic labels; the labels are accurate and on the correct doors (based on the one-line diagram) and a plasticized version of the one-line is attached inside the doors.

- Voltage Transformer Compartment [EUSERC 400] - add location
- Utility Voltage Transformer Fuse Compartment [EUSERC 400]
- Utility Current Transformer Compartment [EUSERC 400]
- Utility Service Termination Compartment [EUSERC 400]
- Utility Metering Compartment [EUSERC 400]
- Voltage label (Voltage Magnitude) [PGE-required label]
- Utility Load-Side Point of Isolation [PGE-required label]
- Utility Line-Side Disconnect, if present.
- One-line (mimic bus) in phenolic red label. PGE requires a label showing the bus layout on the exterior of the door of the gear, or within the exterior door located on the panels if not exposed to energized equipment.

These labels are required on the interior of the switchboard:

- Voltage Phase Signs (A, B, C Required in safety yellow color. Located within the gear.)



Points of isolation (disconnects) are listed on the one-line installed in the correct location per accepted design.

- Utility load-side point of isolation (provided by customer) required downstream of metering
- Utility line-side disconnect (provided by PGE) required upstream of the termination section



Terminations are not allowed in the same compartment as the CTs. Termination heights are a minimum of 62 inches and a maximum of 78 inches.





<input type="checkbox"/>	<p>Terminations are separated:</p> <ul style="list-style-type: none"> <li>▪ For 34.5 kV <ul style="list-style-type: none"> <li>– 15 inches edge to edge minimum between phases</li> </ul> </li> <li><b>NOTE:</b> 18 inches center-to-center minimum between phases <ul style="list-style-type: none"> <li>– 10 inches minimum from phase to grounded material (i.e., Unistrut, crossmember, etc.)</li> </ul> </li> <li>▪ For 12.47 kV <ul style="list-style-type: none"> <li>– 7.5 inches minimum between phases</li> <li>– 6 inches minimum from phase to grounded material (i.e., Unistrut, crossmember, etc.)</li> </ul> </li> </ul>
<input type="checkbox"/>	<p>Termination section bracing does not interfere with cables emerging from the conduit.</p>
<input type="checkbox"/>	<p>Customer equipment, including lightning arresters:</p> <ul style="list-style-type: none"> <li>▪ Is not allowed upstream of the of the utility-controlled pull/termination section or line-side of the metering equipment.</li> <li>▪ Is the adequate voltage rating</li> </ul> <p>Voltage rating is listed on the nameplate</p>
<input type="checkbox"/>	<p>Three (3) ball ground studs are present (one per phase) and installed on a neutral bus</p>
<input type="checkbox"/>	<p>Busses are labeled A, B, C in safety yellow</p>
<input type="checkbox"/>	<p>Neutral and ground connect together in the utility termination section</p> <ul style="list-style-type: none"> <li>▪ Insulated neutral bus extends to load-side point of isolation (disconnect)</li> <li>▪ There is a landing pad for the neutral in the utility termination section</li> </ul>
<input type="checkbox"/>	<p>PGE meter is on the exterior and/or post-mounted</p>
<input type="checkbox"/>	<p>Customer metering, CTs, PTs (or mounts) and all other customer equipment is downstream of load-side point of isolation (disconnect)</p>
<input type="checkbox"/>	<p>There is a landing pad for the neutral in the CT section</p>
<input type="checkbox"/>	<p>24/7 PGE access provided</p>

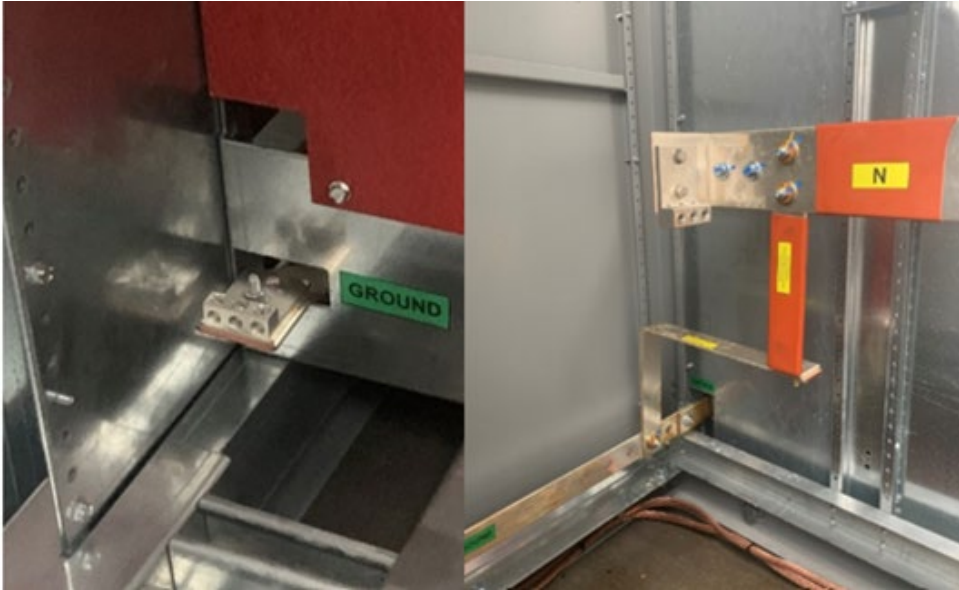



## B.2 PRIMARY GEAR FINAL INSPECTION CHECKLIST

To be completed by a PGE Service Inspector after the customer's equipment has been installed inside the compartments and received the municipality stickers, but before PGE has installed metering equipment.

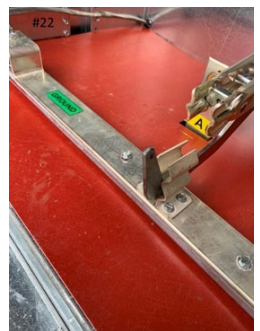
<input type="checkbox"/>	Recheck all Primary Gear Pre-Inspection criteria and ensure that nothing has changed.	
<input type="checkbox"/>	Neutral and ground connect together in the utility termination section <ul style="list-style-type: none"> <li>▪ Insulated neutral bus extends to load-side point of isolation</li> <li>▪ Single point of attachment, not bonded to the bus</li> <li>▪ Minimum four-pack of mechanical terminations each on the PT and on the CT for the neutral</li> </ul>	
<input type="checkbox"/>	Single termination block on bottom of fuse holder on PT side	
<input type="checkbox"/>	Unistrut mounts for PTs on flat horizontal or flat vertical	

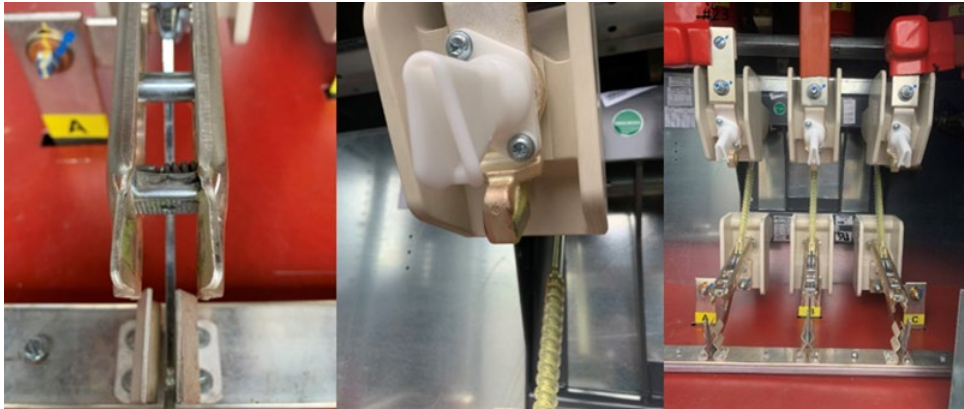
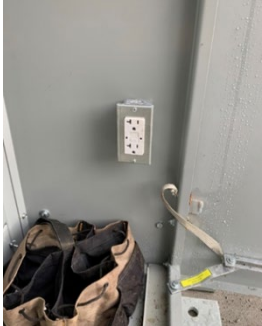
<input type="checkbox"/>	<p>For meter enclosure mounted to gear - Minimum 1-inch PVC conduit running from PT location to where meter is located</p> <p>For post-mounted meter enclosure - Minimum 2-inch PVC conduit running from equipment exterior to where meter is located</p>	
<input type="checkbox"/>	<p>For meter enclosure mounted to gear - Minimum 1-inch PVC conduit running from CT location to where meter is located</p> <p>For post-mounted meter enclosure - Minimum 2-inch PVC conduit running from equipment exterior to where meter is located</p>	
<input type="checkbox"/>	<p>Switch with storable handle on PT side to operate non-load break PT disconnect</p>	
<input type="checkbox"/>	<p>Panel with plexiglass window on PT side to view the switch position</p>	
<input type="checkbox"/>	<p>Grounding bar is present for switch to land in open position</p>	

<input type="checkbox"/>	<p>VT disconnect must be blade and jaw design. Pressure contacts are not acceptable.</p> 	
<input type="checkbox"/>	<p>For DSG participating site, or Qualified Facility site generating 3 MW or greater, a 15 A, 120 VAC receptacle is present to plug meter into (on PGE metering side)</p>	
<input type="checkbox"/>	<p>Hinged clear barrier is present between CTs and access door with minimum 1/4-inch thickness</p>	
<input type="checkbox"/>	<p>Hinged clear barrier (Lexan or Makrolon) is present between termination lugs and the access door with minimum 1/4-inch thickness</p>	



**PGE Corporate Headquarters**

121 S.W. Salmon Street | Portland, Oregon 97204

[portlandgeneral.com](http://portlandgeneral.com)

---