

HT Series

Operating Manual

Genelec HT206B, HT208B and HT210B
Active Home Theater Systems

GENELEC®





HT206B, HT208B and HT210B Active Home Theater Systems

System

The bi-amplified GENELEC HT206B, HT208B and HT210B are two way active speakers designed for high quality Home Theater installations.

Designed as active speakers, these units contain drivers, power amplifiers, active crossover filtering and protection circuitry. The Directivity Control Waveguide™ (DCW™) technology provides excellent frequency balance even in difficult acoustic environments.

Drivers

The HT210B has a 250 mm (10") bass driver and the low frequency response extends down to 36 Hz (-6 dB). The HT208B has a 210 mm (8") bass driver with -6 dB point at 43 Hz and the HT206B a 170 mm (6½") driver with -6 dB point at 47 Hz.

The high frequency driver is a 25 mm (1") (HT210B, HT208B) or a 19 mm (¾") (HT206) metal dome. The uniform dispersion control is achieved with the revolutionary DCW technology pioneered by Genelec. The DCW also provides perfect phase and delay uniformity at the crossover frequency. The bass and treble drivers are magnetically shielded on all models.

Crossover

The amplifier unit contains an active crossover. This is the ideal method for dividing the input signal between the driver units, allowing

the overall response of the system to be optimized to an extent impossible with a passive system.

To maintain uniform frequency balance in differing acoustic environments, three switch groups are included in the active crossover network: treble and bass 'tilt' and bass 'roll-off' switches, which make adjustments in 2 dB steps.

Amplifiers

The amplifier unit is mounted to the rear of the speaker enclosure. It includes individual power amplifiers for each speaker driver, 120+180 watts on the HT210B, 120+120 W on the HT208B and 50+80 W on the HT206B for the treble and bass drivers respectively. The amplifiers incorporate protection circuitry for driver overload protection and amplifier thermal overload protection. Variable input sensitivity allows for accurate level matching with the decoder or preamplifier output section.

The amplifiers are equipped with an "auto-start" function for automatic switching between "standby" and "on" power modes. The power mode can also be changed with a 12 V trigger voltage or external switch type remote control. An indicator LED on the DCW plate shows the system status. Notice that "Autostart" and "Remote control" functions are not available in loudspeakers sold in the EU.

"Autostart" and "remote control" functions can be enabled or disabled as required by using the switches on the amplifier panel.

Installation

Place the loudspeakers in their required positions and aim them towards the center of the listening area. Do not place the speaker in a horizontal position as this may cause acoustical cancellation problems around the crossover frequency.

Sufficient cooling for the amplifier must be ensured if the speaker is installed in a restricted space such as a cabinet or integrated into a wall structure. The minimum clearance for the amplifier is 10 cm (4") to any object. The space adjacent to the amplifier must either be ventilated or sufficiently large to dissipate heat so that the ambient temperature does not rise above 35 degrees Celsius (95°F).

Before connecting up, ensure that the mains switch is set to "OFF". Check that the mains voltage selector is set to your local voltage.

Audio input is made via a 10 kOhm balanced (XLR) or unbalanced (RCA) connector. If the signal source has suitable balanced outputs, we recommend the use of XLR connectors and balanced interconnect cables due to their better resistance to interference. Once connection has been made, the speakers are ready to be powered up.

Setting the input sensitivity

The input sensitivity of Genelec HT series speakers can be matched to the decoder output section or other source by using the

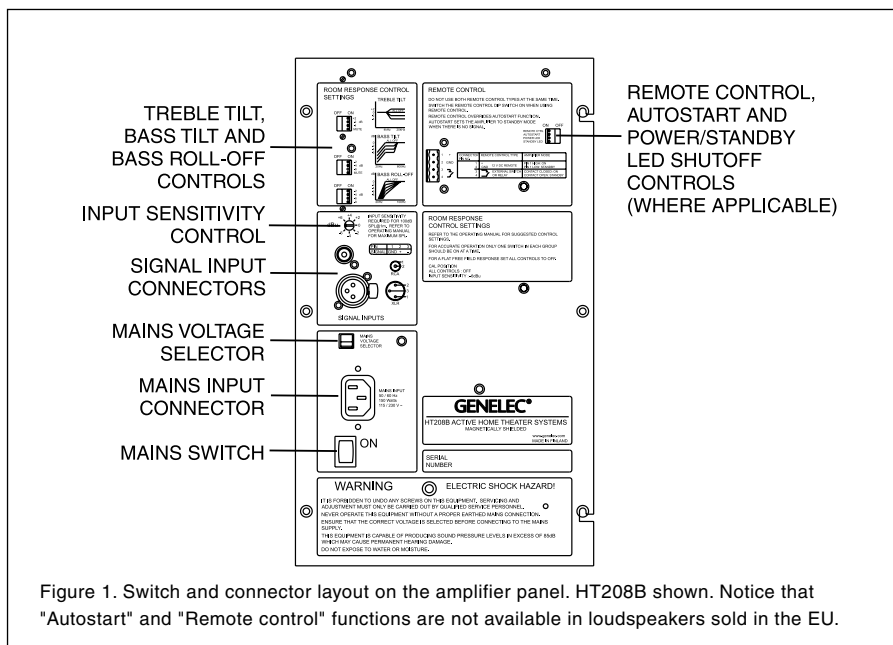

input sensitivity control on the rear panel (see figure 1). A small screwdriver is needed for the adjustment. The manufacturer's default setting for this control is -6 dBu (fully clockwise) which gives a sound pressure of 100 dB @ 1m with -6 dBu input level. Note that to get the full output level of 110 dB SPL, an input level of +4 dBu is needed in this setting.

Setting the tone controls

The acoustic response of the system may also have to be adjusted to match the acoustic environment. The adjustment is done by setting the three tone control switch groups 'treble tilt', 'bass tilt' and 'bass roll-off' on the rear panel of the amplifier. The factory default settings for these controls are 'All Off' to give a flat anechoic response. Figures 3 to 5 overleaf illustrate the effect of the tone controls. Always start adjustment by setting all switches to the 'OFF' position. Then set only one switch to the 'ON' position to select the response curve needed. If more than one switch is set to 'ON' (within one switch group) the attenuation value is not accurate.

Autostart and remote control

The amplifiers are equipped with an "Autostart" function, which automatically turns the amplifier to "standby" mode if an input signal has not been detected for approximately 30 minutes, and back to "on" mode when the signal returns. The function

can be deactivated by turning the "AUTO-START" dip switch to "OFF".

The amplifier mode can also be switched by a remote control unit connected to the respective inputs on the amplifier. Two pairs of connectors are provided, 1 and 2 for a 12 V DC type remote control, and 3 and 4 for an external switch or relay type control. Do not connect two remote controls to the to the speaker at the same time. Activate the function by turning the "REMOTE CONTROL" dip switch on the amplifier panel to "ON". Note that the remote control overrides the "auto-start" function.

"Autostart" and "Remote control" functions are not available in loudspeakers sold in the EU.

Status indicator LED

The status indicator LED changes colour to indicate amplifier status. If the LED is orange, it indicates that the speaker is in "standby" mode. When the speaker is turned to "on" mode, the LED changes to green. If the LED turns red, it indicates that the amplifier thermal protection circuit has been activated. Let the amplifier cool down and check that there is sufficient clearance around the amplifier for cooling.

The LED can be switched off by turning the "POWER LED" and "STANDBY LED" switches to "OFF". Both of these switches should always be set to the same position.

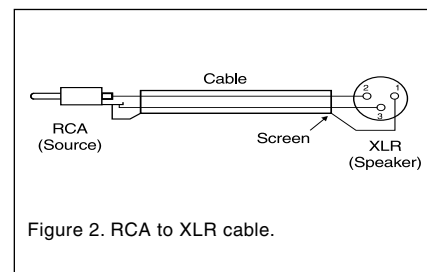

Figure 2. RCA to XLR cable.

Maintenance

There are no user serviceable parts within the speaker. Any maintenance or repair may only be undertaken by qualified service personnel.

Safety considerations

1. Servicing and adjustment must only be performed by qualified service personnel. Opening the amplifier's rear panel is strictly prohibited.
2. It is forbidden to use this product with an unearthed mains cable, which may lead to personal injury.
3. To prevent fire or electric shock, do not expose the unit to water or moisture. Do not place any objects filled with liquid, such as vases on the speaker or near it.
4. Note that the amplifier is not completely disconnected from the AC mains service unless the mains power cord is removed from the amplifier or the mains outlet.

WARNING!

This equipment is capable of delivering Sound Pressure Levels in excess of 85 dB, which may cause permanent hearing damage.

Guarantee

This product is supplied with a two year guarantee against manufacturing faults or defects that might alter the performance of the unit. Refer to supplier for full sales and guarantee terms.

HT206B, HT208B and HT210B Operating Manual

| SYSTEM SPECIFICATIONS | | | |
|--|--|--|--|
| | HT206B | HT208B | HT210B |
| Free field frequency response (+/- 2,5 dB) | 55 Hz - 18 kHz | 48 Hz - 22 kHz | 42 Hz - 21 kHz |
| Maximum peak acoustic output per pair @ 1m measuring distance with music material: | ≥115 dB SPL | ≥120 dB SPL | ≥124 dB SPL |
| Self generated noise level in free field @ 1 m on axis (A-weighted) | ≤ 10 dB | ≤ 10 dB | ≤ 10 dB |
| Drivers, magnetically shielded | | | |
| Bass | 170 mm (6 1/2") | 210 mm (8") | 250 mm (10") |
| Treble | 19 mm (3/4") metal dome | 25 mm (1") metal dome | 25 mm (1") metal dome |
| Bass amplifier power output | Short term 80 W | Short term 120 W | Short term 180 W |
| Treble amplifier power output | Short term 50 W | Short term 120 W | Short term 120 W |
| Amplifier system distortion at nominal output | | | |
| THD | ≤ 0.08% | ≤ 0.05% | ≤ 0.05% |
| SMPTE-IM | ≤ 0.08% | ≤ 0.05% | ≤ 0.05% |
| CCF-IM | ≤ 0.08% | ≤ 0.05% | ≤ 0.05% |
| DIM-100 | ≤ 0.08% | ≤ 0.05% | ≤ 0.05% |
| Harmonic distortion at 90 dB SPL @ 1 m on axis | < 3 % (60...150 Hz) < 0.5 % (>150 Hz) | < 1 % (50...100 Hz) < 0.5 % (>100 Hz) | < 1 % (50...100 Hz) < 0.5 % (>100 Hz) |
| Input impedance | 10 kOhm balanced/unbalanced | | |
| Input connectors | XLR balanced, RCA unbalanced | | |
| Crossover frequency | 3.5 kHz | 2.2 kHz | 1.8 kHz |
| Mains voltage | 100 / 200 or 115 / 230 V | | |
| Power consumption | | | |
| Standby | 7 VA | 5 VA | 5 VA |
| Idle | 10 VA | 15 VA | 20 VA |
| Full output | 100 VA | 160 VA | 200 VA |
| Weight | 7,6 kg (17 lbs) | 12,7 kg (28 lbs) | 21,7 kg (48 lbs) |
| Dimensions | | | |
| Height | 312 mm (12 1/4") | 395 mm (15 9/16") | 495 mm (19 1/2") |
| Width | 200 mm (7 7/8") | 250 mm (9 7/8") | 320 mm (12 5/8") |
| Depth | 240 mm (9 1/2") | 290 mm (11 7/16") | 290 mm (11 7/8") |
| Maximum ambient temperature | 35° C (95° F) | | |

| CONTROLS AND FEATURES | | | |
|---|---|----------|----------|
| | HT206B | HT208B | HT210B |
| Input sensitivity adjustment | +6 to -6 dBu for 100dB @ 1 m, continuously variable | | |
| Treble Tilt control in 2 dB steps from +2 to -4 dB & MUTE | @ 15 kHz | @ 15 kHz | @ 15 kHz |
| Bass Tilt control in 2 dB steps from 0 to -8 dB & MUTE | @ 100 Hz | @ 80 Hz | @ 80 Hz |
| Bass Roll-Off control in 2 dB steps from 0 to -8 dB | @ 50 Hz | @ 40 Hz | @ 40 Hz |
| Autostart* | Automatic power mode switching | | |
| Remote control* | Power mode switching by 12 V trigger or external switch / relay type remote control | | |
| Led shutoff | Shuts off mode indicator led | | |

* These functions are not available in loudspeakers sold in the EU.

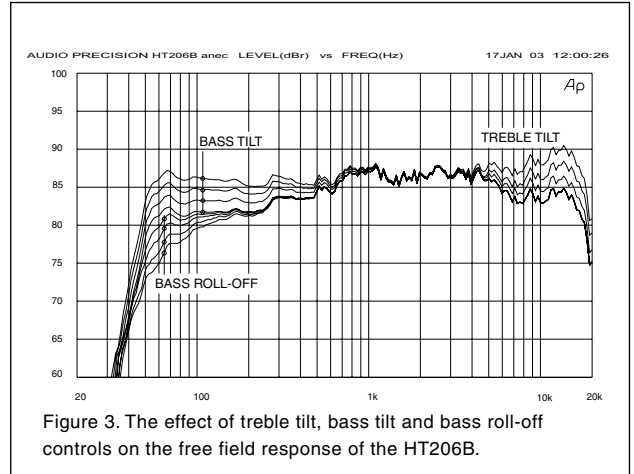

Figure 3. The effect of treble tilt, bass tilt and bass roll-off controls on the free field response of the HT206B.

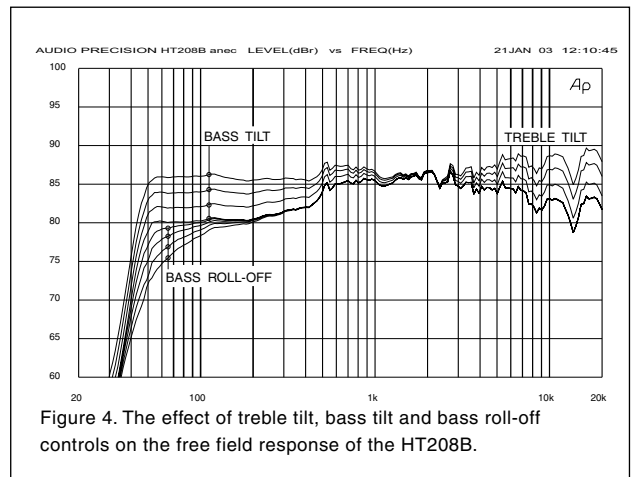

Figure 4. The effect of treble tilt, bass tilt and bass roll-off controls on the free field response of the HT208B.

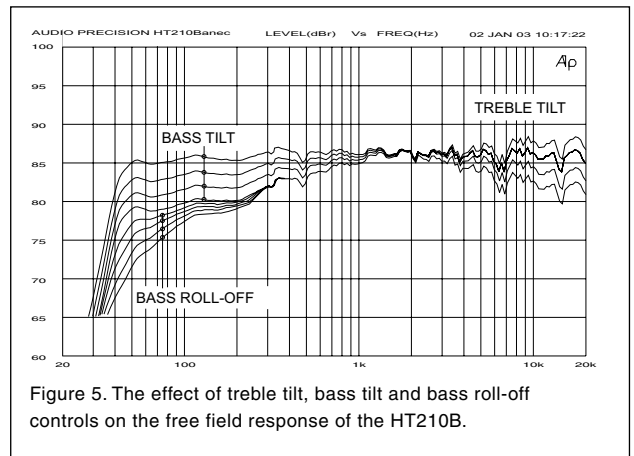

Figure 5. The effect of treble tilt, bass tilt and bass roll-off controls on the free field response of the HT210B.