

4436A

Operating Manual

Genelec 4436A

Smart IP Pendant Installation Speaker

GENELEC®



Genelec 4436 Smart IP Pendant Installation Speaker



Introduction

The bi-amplified Genelec 4436A Smart IP Pendant loudspeaker is a high performance pendant loudspeaker for fixed installations. It requires only one CAT cable to connect, making installation easy. The 4436A is powered using the standard Power-over-Ethernet (PoE) technology, using PoE+ or PoE standards. The proprietary internal power supply in 4436A delivers an impressive short-term SPL.

The 4436A supports Genelec Smart IP technology, and it may be used solely, or together with other Genelec 44xx models. The Smart IP technology provides scalable power, audio and loudspeaker configuration, supervision and calibration features via a standard CAT cable, offering integrators unrivalled power, flexibility, cost-effectiveness and simplicity of installation.

The 4436A has been designed for excellent sound quality and very long lifetime and manufactured using certified sustainable methods. All essential parts of the loudspeaker can be recycled.

The 4436A loudspeaker contains

- Highly efficient dedicated Class D power amplifiers, one for each driver
- Switched-mode power supply technology offering high SPL output using standard PoE+ and PoE power supply with an IP switch or power injector
- Active crossover filter

- Electronic system protection
- Audio-over-IP streaming input
- Balanced analogue line input
- Flexible room acoustic compensation tool set built in

The 4436A is designed for indoor use, in temperatures 15-35 degrees Celsius and non-condensing humidity

Unpacking

A Genelec 4436A set includes the following items. Check that nothing is missing or damaged in transit. If there is a problem with the product, contact your local Genelec dealer.

- 4436A loudspeaker
- Euroblock connector for analogue audio
- A round grille
- A 5 metre (16 ft 7/8 in) adjustable hanging wire

Installation

If you are installing the 4436A to an existing construction, examine the ceiling thoroughly for the shortest and least obstructed cable route. Be careful to avoid cutting or drilling into electrical wires, ventilation or water pipes. All of this is of course much easier when the installation takes place in an unfinished building where the ceiling structure is still open.

Cabling

To get started, connect an Ethernet cable from the PoE+ output in an IP switch to the 4436A Ethernet port. Use at least CAT5 cable or better. The loudspeaker powers up automatically. If the balanced audio input is used, connect it before powering up the speaker. The pin sequence is shown in Figure 9. When the balanced line input is used the loudspeaker must still receive PoE power on the Ethernet cable.

To create a working system, you will need the following:

- An IP switch with a PoE+ (802.3at) output for the 4436A loudspeaker or an IP switch with no PoE support and a PoE+ power injector
- CAT 5 or higher category Ethernet cable with RJ45 connectors
- AES67 or Dante audio-over-IP stream source
- For 4436A setup and configuration, a computer running Windows 10 or Windows 11 operating system
- Genelec Smart IP Manager software
- Dante Controller software or Dante Domain Manager software

Figure 3 shows an example of powering the 4436A with a PoE+ enabled IP switch. With this method, the power budget available for all outputs connected to the IP switch must

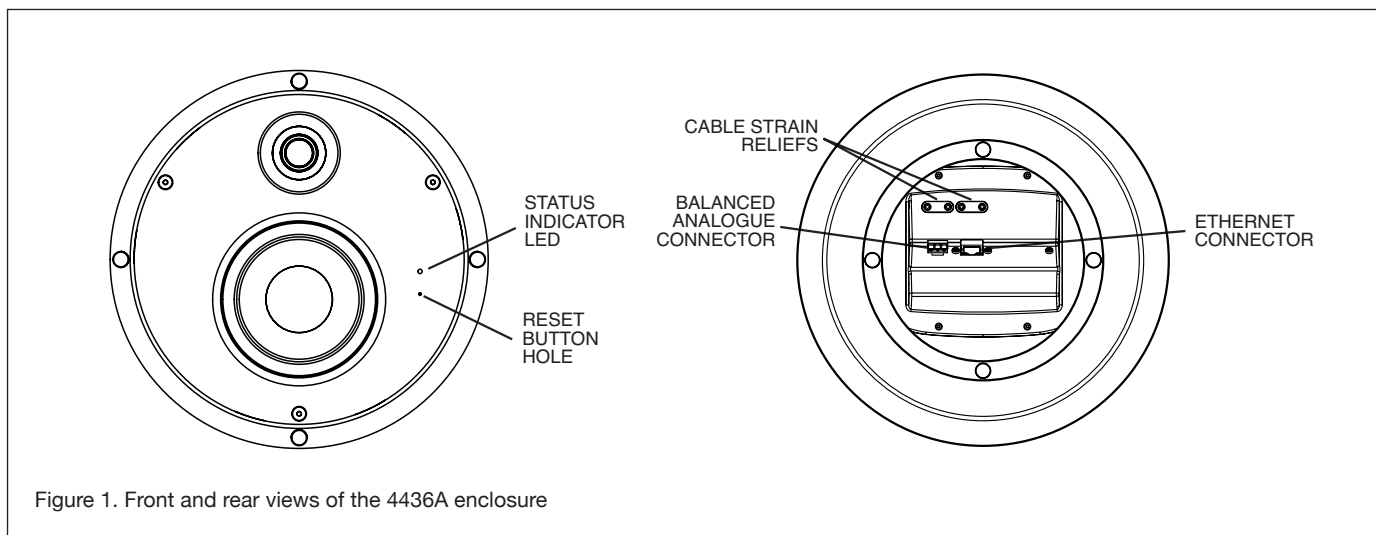

Figure 1. Front and rear views of the 4436A enclosure

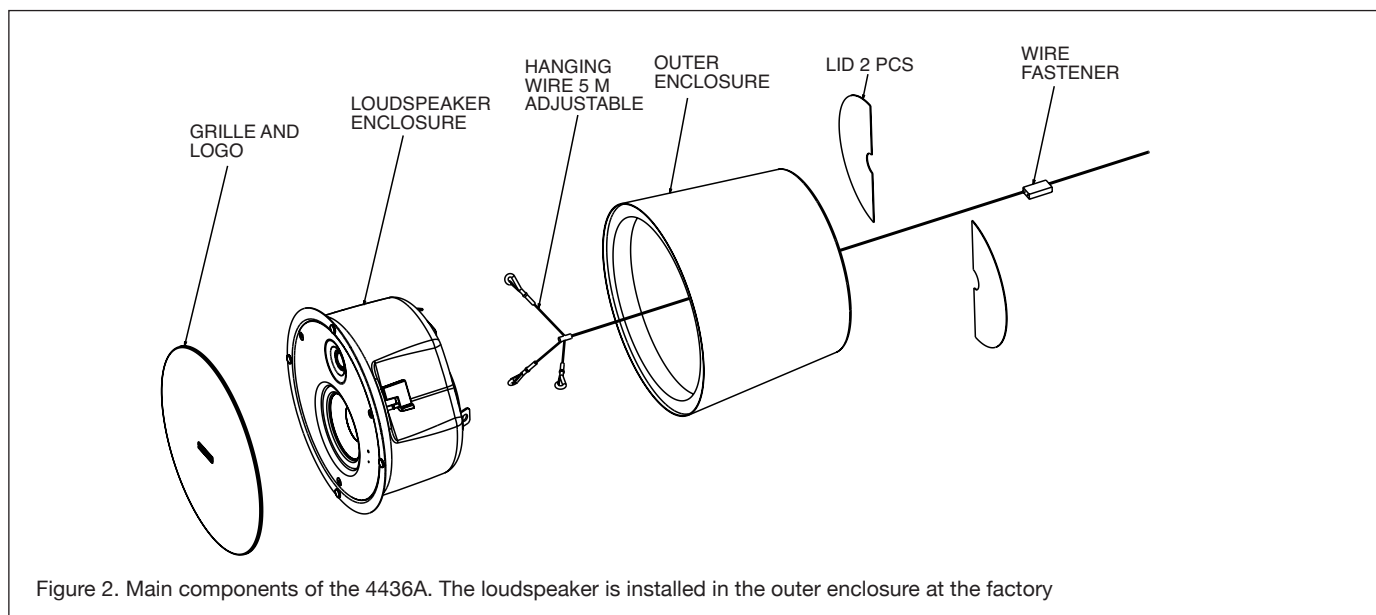

Figure 2. Main components of the 4436A. The loudspeaker is installed in the outer enclosure at the factory

enable each 4436A to run at full PoE+ power. For 4 loudspeakers, the power supply must support 4 x PoE+ power level.

Figure 4 shows an example of powering the 4436A with a PoE+ power injector. This method enables the use of standard non-PoE IP switches. Each power injector must support full PoE+ power level into the device.

How PoE power management works

The 4436A internal power supply stores power for peak output. This enables the output power to exceed the input power for short durations (Figure 5). Music and speech signals are dynamic. They contain high peaks above the average level. These peaks are supplied from the energy

stored in the loudspeaker power supply. The power supply has been dimensioned to work with audio and speech signals, including highly compressed wideband audio signals. The duration of peak output is limited more by the PoE supply and therefore Genelec recommends the use of PoE+ supply.

PoE budget calculation

The 4436A supports automatic negotiation with the IP switch or IP power injector to set the PoE power level. However, in some cases it may be necessary to set the PoE power level in the switch manually.

There are several Power-over-Ethernet standards. The 4436A loudspeaker supports the PoE+ standard but also works with

the lower power PoE standard. When the 4436A also works with lower PoE power, the duration of high SPL output is shortened, and long continuous output signals play at smaller sound level than when the PoE+ power level is used. Genelec recommends using PoE+ power level with 4436A.

Each PoE supply device (IP switch or power injector) has a certain maximum output power capacity. This can limit the number of PoE outputs that can be set on. For 4436A loudspeaker, calculate the output power for each output as 15 W for PoE and 30 W for PoE+. Ensure that the total power does not exceed the switch or power injector total power.

Example: IP switch total power is 150 W. You use PoE+ and four outputs are

connected. The total output power is $4 \times 30 \text{ W} = 120 \text{ W}$. This is smaller than the capacity of the IP switch, 150 W. This scenario is acceptable.

PoE cable loss calculation

There is power loss in the Ethernet cable. The reason for the power loss is that the CAT cable conductor is thin and has considerable resistance. The power loss increases with increasing cable length. The maximum cable length is 100 meters (333 feet). Calculate the power loss in cable at 25 mW/m or 7.4 mW/ft. The 4436A will automatically adapt to the power loss in the cable, but lower input power will affect slightly the duration of the maximum SPL output. In order to minimize the cable loss and to maximize the duration at maximum SPL, consider using power injectors close to the loudspeakers or short cable runs.

Selection of IP switch

Smart IP and 4436A are fully compatible with standard Ethernet and IP switch technology. Genelec recommends using gigabit speed managed IP switches with full PoE+ on each of the outputs intended for 4436A loudspeakers. Managed IP switches offer the ability to configure, manage and monitor the local area network, typically using a web browser user interface, and this helps in creating a well working system.

The IP switches should support Quality of Service (QoS) and be media ready. Differentiated services (DiffServ) typically implements QoS prioritization of IP traffic. DiffServ marks IP packets according priority. In response, IP switches can prioritize media traffic to improve system performance. Differentiated services code point (DSCP) markings in the IP packet headers are sensed by the QoS capable IP switch.

Genelec does not endorse certain IP switch brands as Smart IP works perfectly with all high-quality standard IP switches with these capabilities. Use of 100 Mbps IP switches is discouraged.

Network structure

Genelec recommends always designing a network structure with star topology. Only one IP device (for example, one 4436A) should be connected at one port in an IP switch. IP device ports should not be daisy chained to several IP devices.

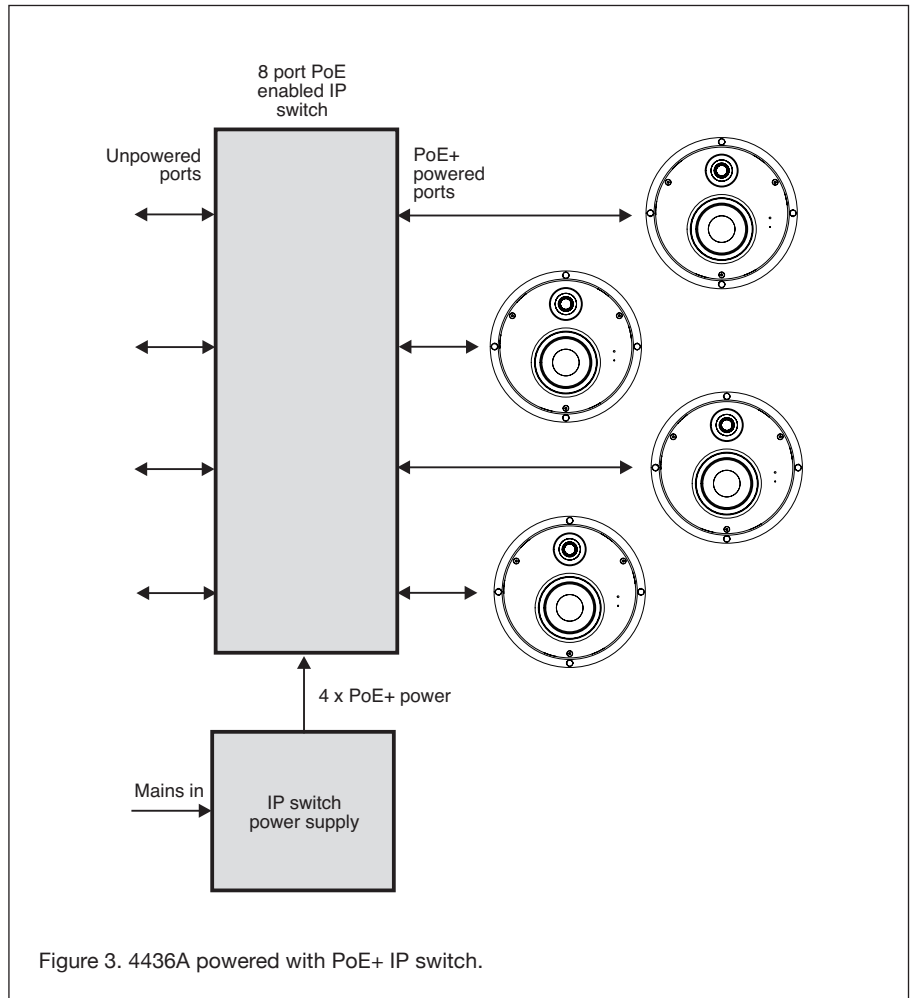

Figure 3. 4436A powered with PoE+ IP switch.

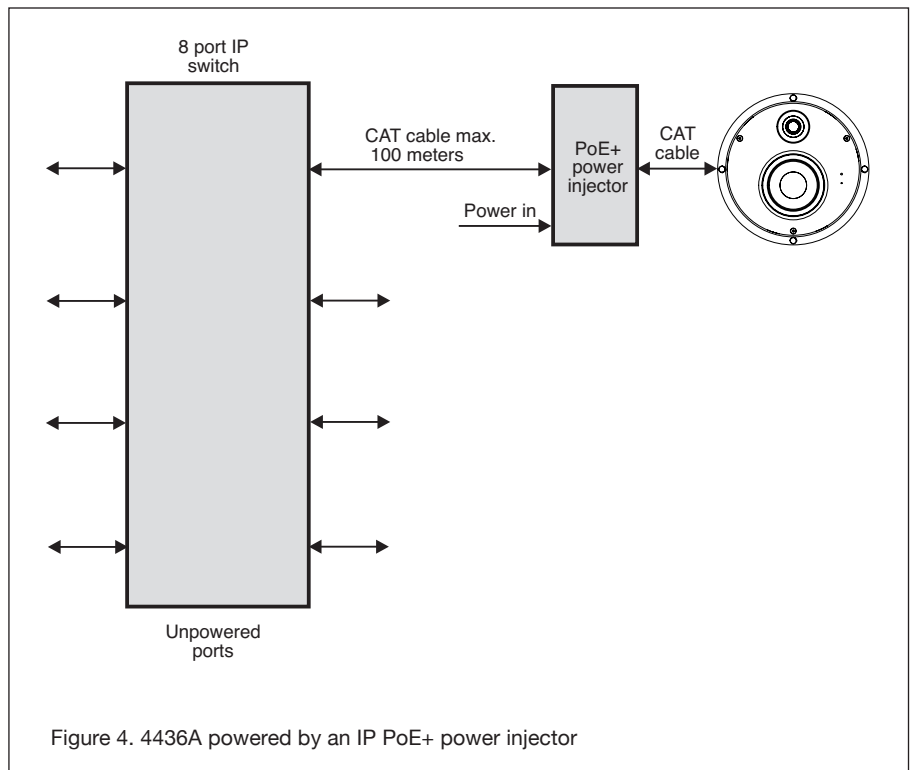

Figure 4. 4436A powered by an IP PoE+ power injector

Audio-over-IP requires the use of cable-based LAN network. Low-latency uncompressed audio-over-IP streaming does not work over WLAN.

Audio-over-IP network

Audio-over-IP streaming supports unlimited number of channels in the playback system. These audio channels are automatically synchronized perfectly in time by the audio-over-IP streaming technology, forming a single playback system. The 4436A accepts AES67 and Dante audio-over-IP streams. The streams are set up with Dante Controller or Dante Domain Manager software. Each 4436A supports reproduction of one or the sum of two audio channels in the stream. The stream audio sample rate can range 32-96 kHz, with 16-24 bit resolution.

The 4436A contains one interface for standard Ethernet IP network connectivity. The network interface speed is 100 Mbps. The interface also allows Genelec's Smart IP Manager software to work on the 4436A. This software is available for AV installers at Genelec web site and runs on Windows 10 or Windows 11 computers. The software allows AV installers to configure an almost unlimited number of rooms, zones, loudspeakers and audio channels, and includes device discovery, a versatile room acoustic equalisation tool set, system organisation and status monitoring.

The 4436A contains an application programming interface (API) supporting control via third-party hardware, software or house automation. The API enables integration to all house and home automation systems. Detailed information about the API are provided in a separate document from Genelec.

A balanced line input is available on 4436A besides the IP interface. The balanced line analogue audio input can be configured with Genelec Smart IP Manager software.

Setting up audio streams

The 4436A can be set to receive one audio channel or a sum of two audio channels in a stream. In addition, using the Smart IP Manager software, 4436A can be set to also sum in the analog input signal as well. Audio stream setup is done by using Dante Controller software. Download the software from <https://www.audinate.com/products/software/dante->

Name	Standard	Power at switch	Min. power at 4436AA
PoE	IEEE 802.3af-2003	15 W	13 W
PoE+	IEEE 802.3at-2009	30 W	26 W

Table 1. PoE and PoE+ power levels.

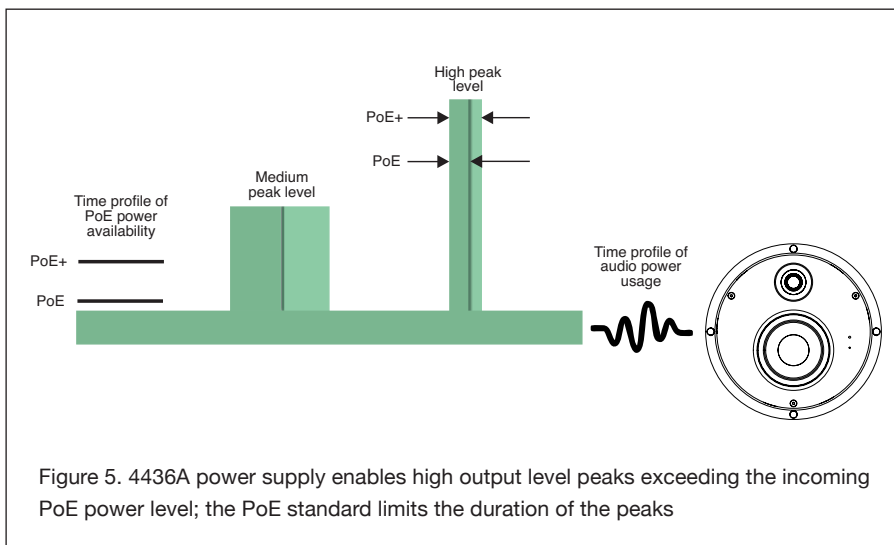

Figure 5. 4436A power supply enables high output level peaks exceeding the incoming PoE power level; the PoE standard limits the duration of the peaks

controller. Dante automatically divides a multichannel stream into several low channel count flows suitable for the speaker and this process is largely automatic.

An AES67 audio stream supported by the loudspeaker can have the maximum of 8 audio channels. The 4436A can select one audio channel or a sum of two channels in a stream. In demanding installations, where there is a wish for stereo reproduction at one or more locations, stereo audio may be sent on the network, and individual 4436A set accordingly for L, R or L+R operation.

The AES67 compatibility mode must turned ON to enable reception of AES67 streams. Follow these instructions:

- Double click on the loudspeaker to be configured. The Device View window opens
- Click AES67 Config -tab
- In the AES67 Mode panel, go to New: and select Enabled
- In the Reset Device panel, click Reboot to reboot loudspeaker with AES67 enabled

Analogue input

An analogue audio input is provided using a screw-mount Euroblock connector. This enables easy connectivity and the option of connecting the balanced audio signal to several loudspeakers in parallel (see figure 8).

The input impedance of the analogue

input is 10 kOhm. The pin sequence of the connector is shown in Figure 7. The number of loudspeakers that can be connected is set by the capability of the source device analogue output. The loudspeakers appear electrically in parallel, reducing the load impedance presented to the source device. Typically, 10 to 20 loudspeakers can be connected on one balanced line output.

Avoid connecting 4436A to the power amplifier outputs. If this must be done, use a balanced attenuator. Typically, an attenuation of about 20 dB is needed. Beware that some power amplifiers can provide a signal that exceeds the maximum voltage at the analogue input, and this can result in failure of the analogue input.

Genelec Smart IP Manager software

Acoustic calibration, zone setup, input selection and loudspeaker management are done using Genelec Smart IP Manager software. This is a software intended for AV installers. Genelec recommends using the Application Programming Interface (API) inside the loudspeaker with house automation systems for the end-user control.

Download Smart IP Manager at <https://www.genelec.com/smart-ip-manager> and follow screen instructions to install. For detailed use of the Genelec Smart IP

manager software, please refer to Smart IP Manager operating manual.

ISS Autostart

The automatic power function ISS (Intelligent Signal Sensing) powers the loudspeaker automatically down when it is not in used and up when the use resumes. ISS can be activated and adjusted with the Smart IP Manager software. Powering down to standby happens after a set time when playback has ended. Playback automatically resumes with an input signal exceeding the level configured using the Smart IP Manager. There is a slight delay in the automatic powering up. If this is undesirable, ISS can be disabled with Smart IP Manager.

The indented use of this loudspeaker requires that the IP network interface is continuously enabled also in the standby mode. This enables the ISS to wake up with an API command or in response to IP audio stream. The power consumption in the ISS state for 4436A is 4 W. To save more power, the PoE+ power supply in the Ethernet switch or PoE injector can be turned off. However, loudspeaker wakeup will then take slightly longer time and the loudspeaker does not respond to any command on the IP network while it is not powered.

Reset button

The factory setting for all acoustic settings is “OFF”, sensitivity attenuator set to 0 dB, and delay set to 0 ms. Both the audio-over-IP stream and analogue inputs are selected to play. Audio stream settings are reset. With the factory settings, all that is needed to play audio is to provide a signal to the analogue input or to configure an audio-over-IP stream in the stream input. Set stream again to resume normal streaming operation.

If necessary, the 4436A can be reset to factory settings by inserting a pin through a small hole on the front baffle, near the status indicator LED (see fig. 1). Keep the button pressed for over ten seconds. Do not use excessive force. The loudspeaker indicates that the reset process starts. Then you can release the button but do not disconnect power supplied by the Ethernet cable until the reset process is complete. Once the reset is complete, the loudspeaker becomes available and active on the Smart IP Manager again. This typically takes less than one minute.

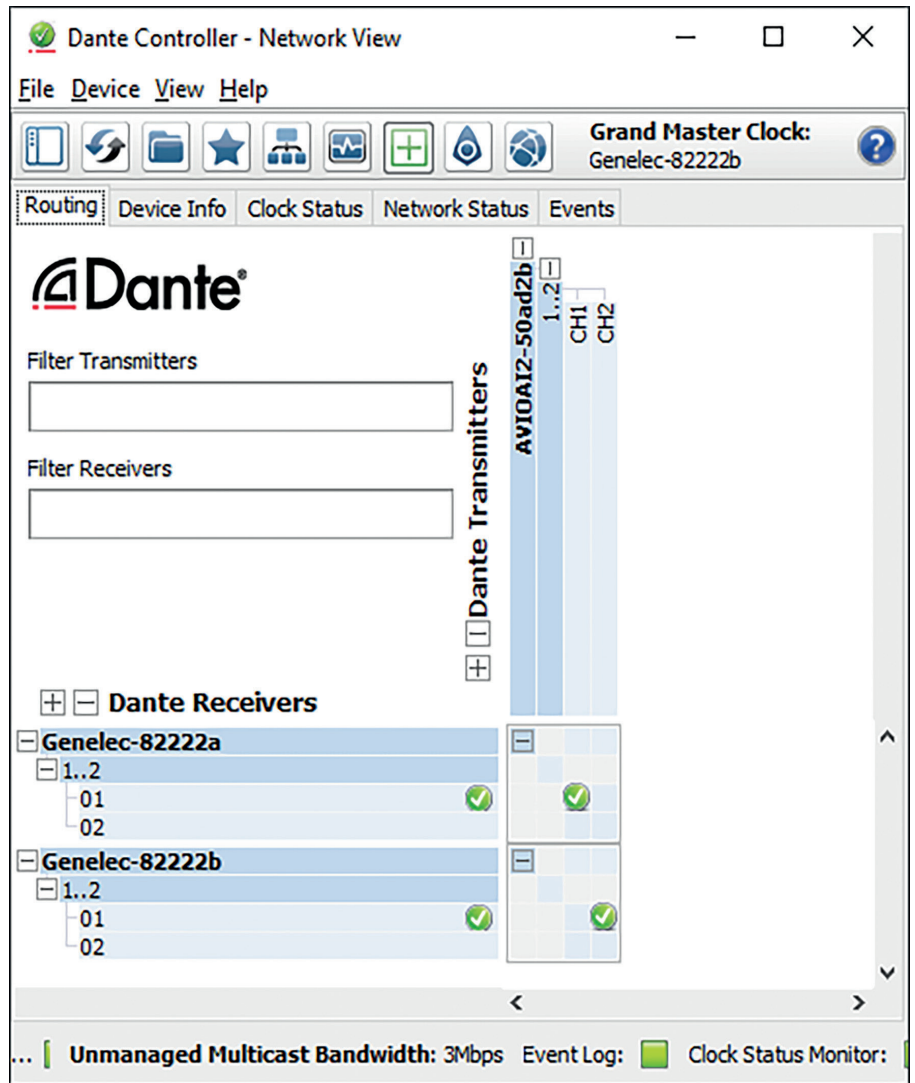

Figure 6. Setting up audio streams in the Dante controller

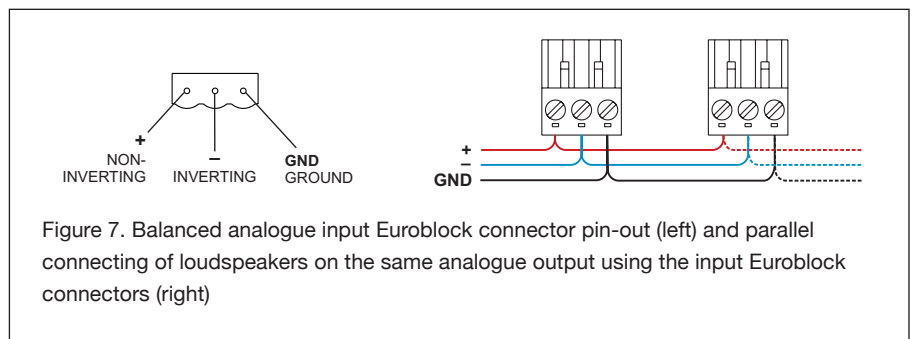

Figure 7. Balanced analogue input Euroblock connector pin-out (left) and parallel connecting of loudspeakers on the same analogue output using the input Euroblock connectors (right)

Painting the loudspeakers

The loudspeaker metal mesh grille can be spray painted to match the surrounding colour. Do not paint the loudspeaker front baffle and drivers, or try to paint the grille while it is attached to the loudspeaker. Paint the grille separately with a thin spray. Do not

use brushes or rollers. Be careful to avoid clogging the grille with paint.

Status indicator LED

The LED light on the front baffle has some status indication functions that are listed in Table 2.

Automatic protection circuits

The 4436 system has protection circuits against loudspeaker driver thermal overload and amplifier overheating. The protection system resets automatically so the user only has to turn the input level down to ensure that it does not reactivate.

Driver thermal overload protection protects the drivers from damage caused by prolonged overdriving with excessively high or distorted signal. If this occurs, the circuit automatically reduces playback volume. To avoid this, lower the listening volume if the sound becomes harsh and distorted at high sound pressure levels.

Maintenance

There are no user serviceable parts within the loudspeaker. Any maintenance or repair should only be undertaken by qualified service personnel.

Safety considerations

- Servicing and adjustment may only be performed by qualified service personnel
- The loudspeaker must not be opened.
- Do not expose the loudspeaker to water or moisture
- Do not place objects filled with liquid, such as vases, on the loudspeaker or near it
- This loudspeaker can produce sound pressure levels in excess of 85 dB, which may cause permanent hearing damage.
- Free flow of air behind the loudspeaker is necessary to maintain sufficient cooling. Do not obstruct airflow around the loudspeaker
- The loudspeaker is not disconnected from the power supply unless the CAT cable is removed from the loudspeaker.
- Ensure that the mounting in the ceiling is able to carry the full weight of the loudspeaker in all circumstances, the installations have been designed and are implemented according to the local safety regulations and follow principles of good workmanship. Using a safety wire is recommended
- Genelec products and accessories can come with instructions on the proper methods of installation and use. Follow these instructions

Sound Pressure Levels in excess of 85 dB, which may cause permanent hearing damage.

Guarantee

This product is supplied with a two year guarantee against manufacturing faults or defects that might alter the performance of the unit. Refer to supplier for full sales and guarantee terms.

Colour	Indication
Green	On
Slow blinking green	Sleeping
Red	Missing AES/EBU signal
Fast blinking red	Power failure
Yellow	No inputs selected
Dark (Off)	Standby

Table 2. 4436A status indicator LED colours

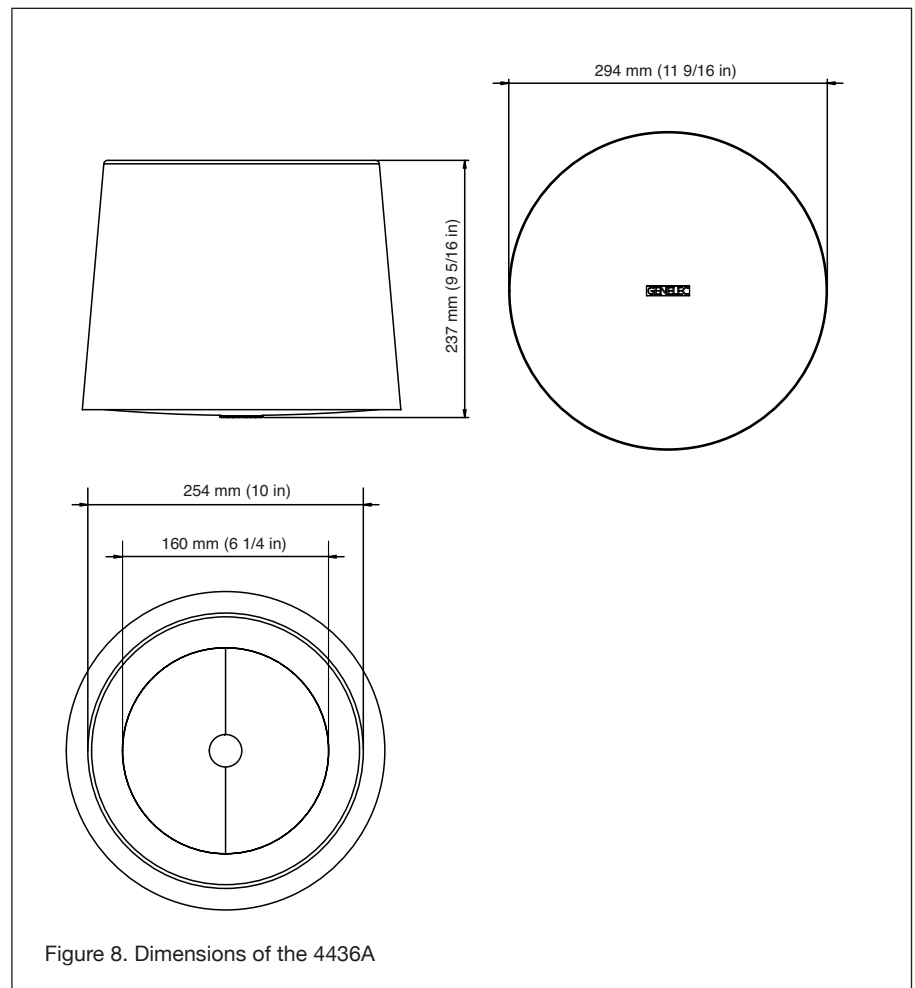

Figure 8. Dimensions of the 4436A

WARNING!

This equipment is capable of delivering

SYSTEM SPECIFICATIONS	
Lower cut-off frequency, -6dB	≤ 58 Hz
Upper cut-off frequency, -6dB	> 39 kHz
Frequency response within ± 2.5 dB	70 Hz – 20 kHz
Minimum delay from analogue input to acoustic output	2.2 ms
Maximum short-term sine wave output on axis in half space, average 100 Hz to 3 kHz, at 1 m, using PoE+ power	≥ 104 dB SPL
Maximum long-term RMS acoustic output in same conditions with IEC-weighted noise, at 1 m using PoE+ power (limited by driver unit protection circuit and the PoE power supply being used)	≥ 96 dB SPL
Maximum peak acoustic output per unit in a listening room with music material, at 1 m, using PoE+ power	> 107 dB SPL
Self-generated noise level in free space, at 1 m on the acoustical axis, A-weighted	≤ 10 dB
Harmonic distortion at 85 dB SPL at 1 m on axis frequency range 70 – 200 Hz frequency range >200 Hz	< 5% < 0.5%
Dispersion angle (degrees), horizontal	120°
Dispersion angle (degrees), vertical	100°
Bass driver	130 mm (5 in) cone
Treble driver	19 mm (3/4 in) metal dome
Weight	5.3 kg (11.7 lb)
Dimensions H x W x D	294 x 237 mm (11 5/8 in x 9 3/8 in)

Maximum short-term output level is limited by the PoE technology being used and the crest factor of the audio signal. The stated values are typical for music and speech signals. Maximum long-term output level can be further limited by loudspeaker system protection. Genelec recommends using PoE+ whenever possible. Using lower-power PoE can limit short-term maximum and long-term maximum, depending on the characteristics of the signal being reproduced. User selectable filters can be set to positive gain. Positive gain must be used with care as it is possible to cause premature overload of the loudspeaker at specific frequencies.

INPUT / CROSSOVER SECTION	
Ethernet connection	100BASE-TX 1 x RJ45
Nominal SPL with 0 dBFS digital audio input at maximum sensitivity	130 dB SPL
Audio-over-IP streaming formats	AES67, Dante
Analogue input, connector type	3 pin Euroblock
Analogue input, Input impedance	10 kOhm, balanced
Analogue input level for 100 dB SPL at 1 m	-6 dBu
Analogue input, maximum input signal	24 dBu
Crossover frequency, bass/treble	2.9 kHz
Number of user-adjustable filters	20
User selectable filters, choice of function for each user-adjustable filter	Parametric notch High frequency shelf Low frequency shelf Bass roll-off Bass tilt Treble tilt
User selectable filters, parameter adjustment ranges for a notch filter Gain Q-value Center frequency	-20...+2 dB 0.1...20 10 Hz...16 kHz
Sensitivity adjustment range	-60...0 dB
Delay adjustment range	0...98 ms

AMPLIFIER SECTION

Bass amplifier output power, short-term	50 W
Treble amplifier output power, short-term	50 W
Supply power at switch, power-over-Ethernet PoE+ (Class 4) PoE (Class 3)	30 W 15 W
Supported PoE standards PoE+ (supports signature and LLDP) PoE (supports signature)	IEEE 802.3at IEEE 802.3af
CAT cable specification	5, 5e, 6
Maximum CAT cable length	100 m (333 ft)
Power consumption in idle	5 W
Power consumption in ISS power-down mode	4 W

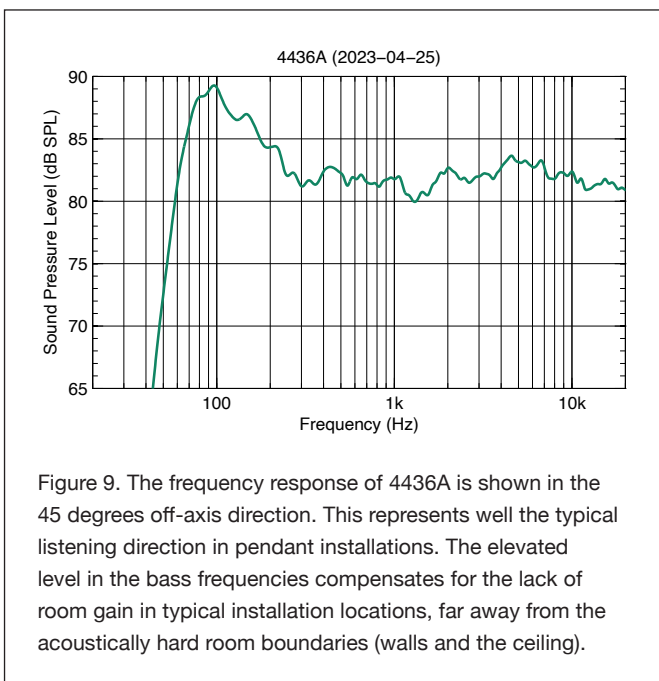

Figure 9. The frequency response of 4436A is shown in the 45 degrees off-axis direction. This represents well the typical listening direction in pendant installations. The elevated level in the bass frequencies compensates for the lack of room gain in typical installation locations, far away from the acoustically hard room boundaries (walls and the ceiling).

Genelec 4436A Smart IP Pendant Installation Speaker

GENELEC®

International enquiries:

Genelec, Olvitie 5
FIN-74100, Iisalmi, Finland
Phone +358 17 83881
Fax +358 17 812 267
Email genelec@genelec.com

In the U.S. please contact:

Genelec, Inc., 7 Tech Circle
Natick, MA 01760, USA
Phone +1 508 652 0900
Fax +1 508 652 0909
Email genelec.usa@genelec.com

In China please contact:

Beijing Genelec Audio Co.Ltd
Room 101, Building B33,
Universal Business Park,
No.10 Jiuxianqiao Road,
Chaoyang District,
100015 Beijing, China
Phone +86 (10) 5823 2014
+86 400 700 1978
Email genelec.china@genelec.com

In Japan, please contact:

Genelec Japan Inc.
2-22-21 Akasaka, Minato-ku
07-0052, Tokyo
Phone +81-3-6441-0591
genelec.japan@genelec.com
Email genelec.japan@genelec.com

In Sweden please contact

Genelec Sverige
Tureholmsvägen 12
125 35 Älvsjö
Sweden
Phone +46 8 449 5220
Email sweden@genelec.com