

GENELEC®

ACTIVE MONITORING

Genelec 1034B
Control Room Monitoring System

Operating Manual



1. DESCRIPTION

The GENELEC 1034B monitor is designed for neutral sound reproduction at high SPLs in large control rooms. The system comprises of a 160 litre cabinet and a 19" 7U rack mount amplifier unit.

The speaker cabinet contains two 305mm (12") bass drivers, a 130mm (5") midrange, and a 25mm (1") treble driver. The midrange and treble drivers are mounted in a Genelec Directivity Control Waveguide (DCW) which can be rotated through $\pm 90^\circ$ for either horizontal or vertical mounting. The cabinet low frequency -3dB point is at 32 Hz and the bass response extends down to 27 Hz. The high frequency response extends up to 22kHz (-3dB).

Each amplifier unit contains a 3 channel active crossover, driver overload protection circuits, and 4 separate power amplifiers producing 2 x 400W, 350W and 120W of short term power in the bass, midrange, and treble channels respectively. The crossover filter incorporates tone controls to enable the user to accurately match the speaker to the local acoustic environment.

2. UNPACKING AND INSTALLATION

2.1 UNPACKING

The Genelec 1034B monitoring system can be transported as a pair or as a

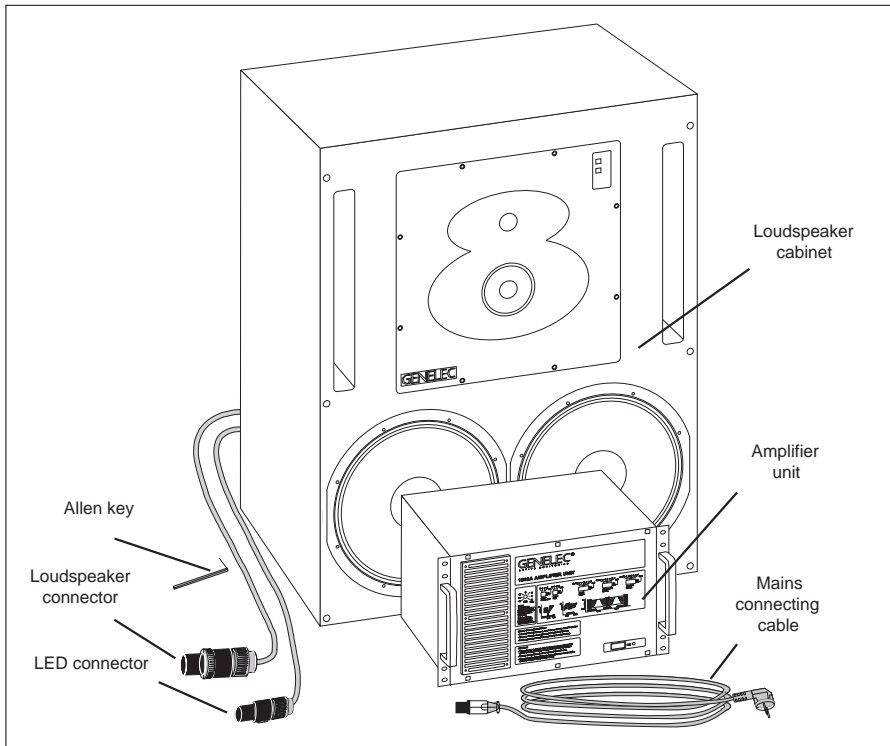

Fig 1. The 1034B system.

single system. A pair is shipped in a single box, containing two cabinets, two amplifier units, two mains connecting cables, two LED connecting cables, two loudspeaker connecting cables and one Allen key. (See Fig 1)

Before installing the system, check all items for damage and omissions. If there are any damaged products, contact directly the distributor and insurance agent. If there are any missing components, contact your local dealer or GENELEC.

2.2 AMPLIFIER POSITIONING

The Genelec 1034B amplifier electronics are encased in two standard 19" 7U rack cases. The unit should be well ventilated to prevent excessive overheating, there must be a supply of air to the front and rear of the amplifier unit. If the system overheats it will stop operating until a safe temperature is reached.

Make sure that the amplifier is positioned so that the speaker connecting cables will reach. Longer cable lengths can be ordered from GENELEC upon special request. A space 100 mm (4") deep should be left behind the rear panel of the amplifier unit to allow for the cable connectors.

Check that the amplifier unit is wired to the correct mains voltage for your power supply. The correct mains voltage for the amplifier unit is shown at the bottom of the sticker on the rear panel of the amplifier unit.

2.3 LOUDSPEAKER POSITIONING

The 1034B control room monitor is designed to be flush mounted in either the vertical or horizontal configuration. The DCW should be rotated so that the treble and midrange drivers align vertically. This ensures that optimum stereo symmetry is obtained.

IMPORTANT-The DCW plate is heavy, care must therefore be taken when removing and replacing the DCW. To rotate the DCW plate, proceed as follows:

- Place the speaker in its intended listening orientation.
- Unscrew the eight M5 fixing screws on the edges of the plate using the 4mm Allen key provided with the system.
- Carefully pull the plate a small distance away from the cabinet.
- Rotate the DCW so that the midrange and treble drivers are aligned vertically (treble driver on top) and remount the DCW plate reversing the procedure above.

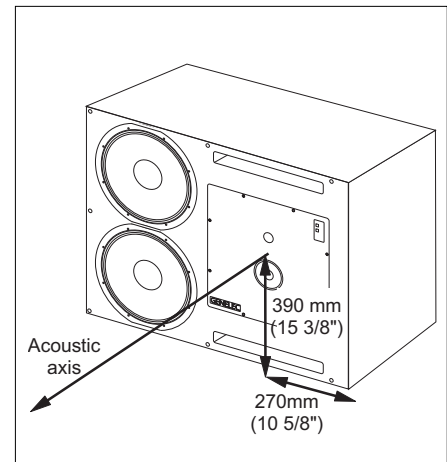

Fig 2.1 Horizontal configuration.

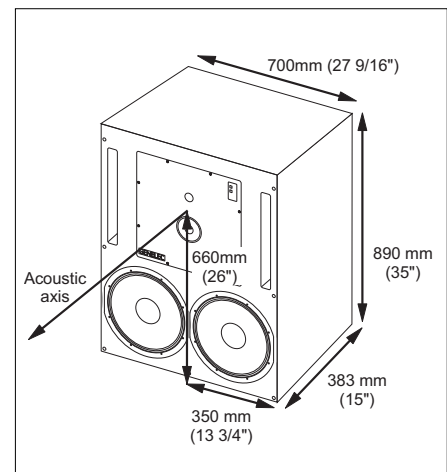

Fig 2.2 Vertical configuration.

2.4 FLUSH MOUNTING OF THE SPEAKER

Although the 1034B may be used successfully as a free standing speaker, flush mounting is strongly recommended for acoustical reasons. Flush mounting improves the bass response and efficiency and also enhances the midrange transient and frequency response.

The speaker has its acoustical axis midway between the midrange and treble drivers. This axis should be used as the listening and measuring axis of the system. (See Fig 2.1 and Fig 2.2)

The listening position should be between 2 ... 3.5m (6½ ... 11½') from the speakers. The speaker should be aimed so that the

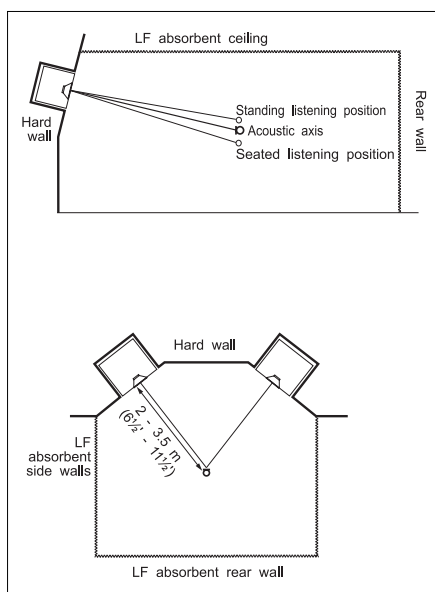

Fig 3. Speaker mounting.
Side view (top), Plan view (bottom).

vertical acoustical axis of the two speakers meet midway between the standing and seated listening position (1.4m - 4'7" from the floor). This allows the correct frequency response to be received by a standing or seated person. The speakers should not be mounted too high as this increases the required vertical tilt of the speaker and reduces the optimum listening area.

The ceiling, side walls and especially the rear wall should be acoustically absorbent at low frequencies. The speaker mounting wall should be acoustically hard and therefore reflective. The speaker mounting wall should be angled so that the speakers are correctly aimed. Great care should be taken over how the speaker is mounted into the wall.

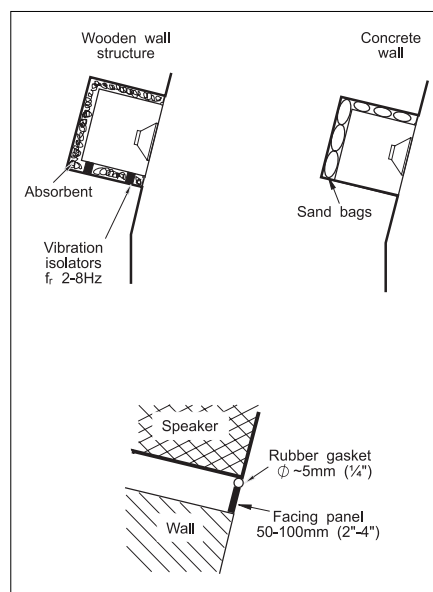

Fig 4. Speaker mounting details.

Note the following:

- A space 50...100 mm (2..4") wide can be left around the speaker.
- Cover the space around the speaker with a facing panel, this should be fixed to the wall. Leave a gap of about 5..10 mm (¼..½") between the speaker and the panel. Fill this gap with a soft rubber gasket to allow for possible cabinet movement.
- Ensure that the speaker cables can reach the rear of the speakers.
- If a light (e.g. wooden) wall is used, the speaker cabinet should be mounted on vibration isolators, with a resonant frequency of around 2...8Hz, to prevent vibrations from being transmitted to the wall and impairing the low frequency performance. The space around the cabinet should be filled with absorbent mineral wool or foam plastic. The walls must be well braced.

- For a solid wall (e.g. concrete), the speaker may be directly mounted to the wall without vibration isolators. The space around the cabinet should be filled with mineral wool or sand bags.

Discontinuities in the speaker mounting wall will cause diffraction, which leads to inferior frequency response and stereo imagery, so:

- Ensure that the cabinet is flush with the surface of the wall.
- If a decorative cloth frame is used to cover the wall, make sure that the edges adjacent to the speaker are less than 20 mm (¾") deep. The cloth must be very thin Tricot or acoustically transparent material, otherwise the high frequency response of the system will be adversely affected. GENELEC approved cloth grilles are available.

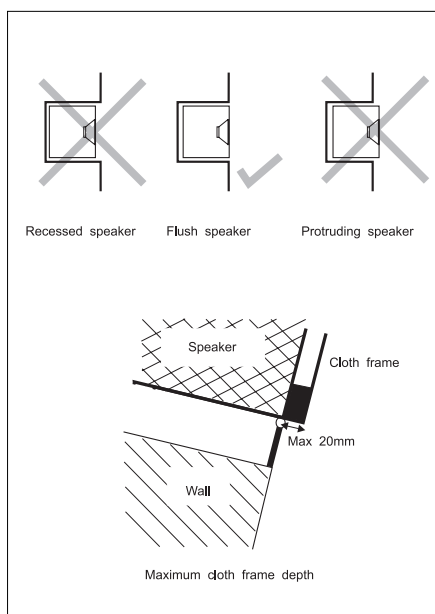

Fig 5. Eliminating discontinuities.

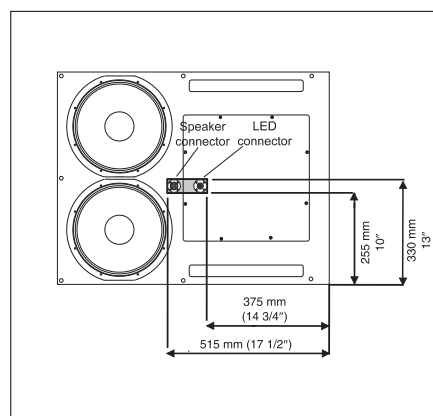

Fig 6. Recess for loudspeaker connectors. (Front view)

2.5 RECESS FOR LOUDSPEAKER CONNECTORS

The speaker connector cable extends 100 mm (4") from the rear panel of the loudspeaker. Therefore, a space at least 100 mm (4") deep must exist to allow for the cable behind the loudspeaker. The dimensions of the recess should be at least 100x140x75 mm (4"x5½"x3"), as shown in Fig. 6. Note that the connectors are positioned off-centre. Therefore, if the loudspeaker is rotated for a left and right channel, the recess will be at different heights on the left and right side. This occurs when the speakers are mounted in the horizontal configuration.

2.6 CONNECTING CABLE

The two connecting cables have different types of connectors at each end, a loudspeaker connector and an LED connector. The loudspeaker connector is larger than the LED connector, therefore the connectors cannot be inserted into the wrong socket. Insert the connectors into the appropriate sockets found on the rear panel of the amplifier unit and the rear of the loudspeaker.

To insert the connectors proceed as follows:

- Insert the connectors into the sockets and turn the connectors clockwise. The connectors lock automatically.
- The electrical connections are only made when the connectors are fully inserted.

To remove the connectors proceed as follows:

- Pull the release lever on the connector and turn the connector counterclockwise simultaneously. The connector can now be removed from the socket.

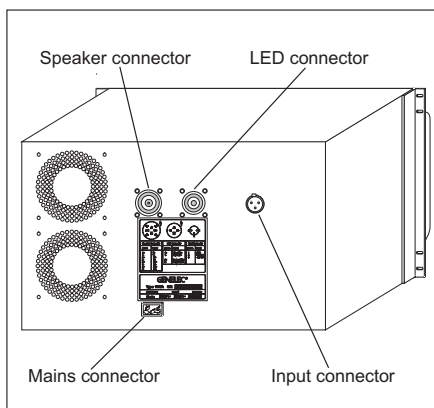

Fig 7. Amplifier unit connectors.

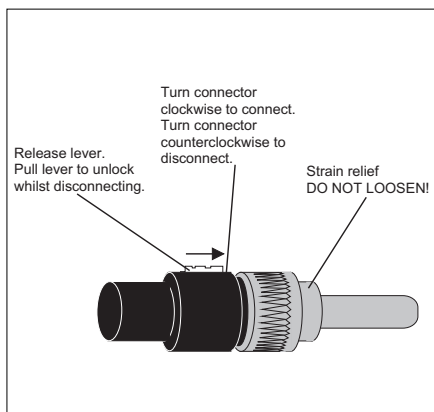

Fig 8. Speaker/LED connector

3. ACOUSTICAL SETUP

3.1 INPUT SENSITIVITY ADJUSTMENT

The input sensitivity of the 1034B can be adjusted to match the output signal level of the driving source. This is done by turning the 'Input sensitivity' trimmer, which is accessed through the front panel of the amplifier unit. However, an accurate left/right balance is obtained when the trimmer is set to the fully clockwise 'cal' position. Leaving the input sensitivity trimmer in the 'cal' position is therefore recommended.

To obtain the maximum sound pressure level of 123 dB SPL, with the input sensitivity set to -6 dBu, a signal level of +20 dBu is required.

3.2 ADJUSTMENT OF THE TONE CONTROLS

The frequency response of the system should be adjusted to match the listening room's acoustic environment. This adjustment is made using the tone controls, 'BASS TILT', 'BASS ROLL-OFF', 'BASS LEVEL', 'MIDRANGE LEVEL', and 'TREBLE LEVEL'. These controls are accessed through the amplifier unit's front panel. The default setting of these controls is in the 'off' position, which yields a flat frequency response when the speaker is operated in an anechoic environment. Note that only one switch in each control group should be in the 'on' position.

The room normally boosts the low frequencies compared with free field conditions. To get a flat room response, adjustments to the bass tone control switches are usually required. See table 1 below

for suggested starting positions of the tone controls in four different room types. The table shows that the midrange and treble controls should be left in their free field positions, since these frequencies are controlled by the speaker more than the room. Acoustical measurements, and precise listening tests should be completed by qualified personnel, to determine the optimum tuning of the speaker to the room.

3.3 FREQUENCY RESPONSE MEASUREMENT IN THE CONTROL ROOM

The overall sound balance experienced at the listening position can, to a certain extent, be measured with steady state signals (e.g. pink noise, warble sine etc.) and a corresponding frequency analyser. However, the results obtained are very sensitive to the measuring methods and the equipment used.

Recommended Measuring Equipment.

Microphone

- Always use a laboratory grade measurement microphone.
- B&K 4134 (or similar) for far field, 4133 or 4165 (or similar) for near field below 8kHz.
- B&K 4004 and 4007 (or similar) up to 8kHz.

Do not use a microphone having a polar pattern other than omnidirectional, or one not having an accurately known frequency response.

Speaker Mounting Environment	Control				
	Bass roll off	Bass tilt	Bass level	Mid level	Treble level
1. Flat anechoic response (factory setting)	ALL OFF	ALL OFF	ALL OFF	ALL OFF	ALL OFF
2. Free standing in a heavily damped room	ALL OFF	-2 dB ON	ALL OFF	ALL OFF	ALL OFF
3. Free standing in a reverberant room	ALL OFF	-2 dB ON	-1 dB ON	ALL OFF	ALL OFF
4. Flush mounted in a hard wall	ALL OFF	-4 dB ON	-1 dB ON	ALL OFF	ALL OFF
5. In a corner	-4 dB ON	-6 dB ON	-2 dB ON	ALL OFF	ALL OFF

Table 1. Suggested starting positions for tone controls.

Signal Source

Use a signal source which is suitable for the type of analyser being used. *Do not* use a noise generator which is integrated into a mixing console, since these signal generators tend to have a very coarse spectrum content and are not intended to be used for measurement purposes.

Analyser

Any professional quality real time analyser or tracking plotter can be used. ($1/3$ or $1/1$ octave analysis is usually sufficient for frequency response balancing)

3.4 NEAR FIELD MEASUREMENT.

This measurement gives an indication of the direct sound radiation of the loudspeaker below 1kHz.

- Set the microphone 1m away from the loudspeaker on the acoustic axis. (See Fig 2.1 and 2.2)
- Measure the frequency response of the speaker, and adjust the tone controls to achieve a flat frequency response below 1kHz.

Make sure that any sound reflecting objects such as chairs etc. are removed from the close proximity of the loudspeaker.

3.5 LISTENING POSITION MEASUREMENT.

Once the near field frequency response measurement has been made, the frequency response at the listening position can be determined by the same means. When comparing the results, the following items should be noted.

High frequency roll-off

This is due to the following physical factors:

- Increasing room and air absorption with higher frequencies.
- Increasing loudspeaker and microphone directivity with increasing frequency.

Low frequency irregularities.

These are caused by

- Insufficient standing wave absorption in the control room.

- Reflections from nearby boundaries (Floor, ceiling, walls) interfering with direct sound.

Incorrect vertical speaker alignment can cause interference dips at the upper crossover frequency (around 3.2kHz). Hence care should be taken aiming the speaker correctly towards the listening position. (See Fig 3.)

4. OVERLOAD INDICATORS

Each speaker is provided with two LED's marked 'CLIP PROTECT (FAULT)' and 'READY'. The green 'READY' LED indicates that the amplifier system power is switched on, and that the speaker is ready for use. The red 'CLIP PROTECT (FAULT)' LED indicates that the amplifier system is overloaded or that the driver protection circuit is activated. If the red LED lights, reduce the signal level so that the LED stops blinking. If this LED stays lit constantly, then the amplifier thermal protection circuitry has activated. Let the amplifier cool down, and ensure that the amplifier is adequately ventilated.

5. MAINTENANCE

There are no user serviceable parts within the amplifier unit. Any maintenance of the unit should only be undertaken by qualified service personnel.

Ensure that only fuses of the appropriate voltage and current ratings are used if a fuse has to be replaced.

REMEMBER to disconnect the power supply by removal of the mains cable before changing a fuse.

Clean the amplifier unit's air filter every six months, or more frequently in dusty environments. The air filter is located behind the grille, found to the left of the front panel. The air filter can be cleaned with a vacuum cleaner without removing the grille.

6. SAFETY CONSIDERATIONS

Although the 1034B has been designed in accordance with international safety standards, to ensure safe operation and to maintain the instrument under safe oper-

ating conditions, the following warnings and cautions should be observed.

Servicing and adjustment should only be performed by qualified service personnel. Opening the amplifier's front panel is strictly prohibited except by such persons who are aware of the hazards involved.

It is forbidden to use this product with an unearthed mains cable, which may lead to personal injury.

Warning!

This equipment is capable of delivering sound pressure levels in excess of 85dB, which may cause permanent hearing damage.

7. GUARANTEE

This product is guaranteed for a period of ONE year against faults in materials or workmanship. Refer to supplier for full sales and guarantee terms.

GENELEC®

ACTIVE MONITORING

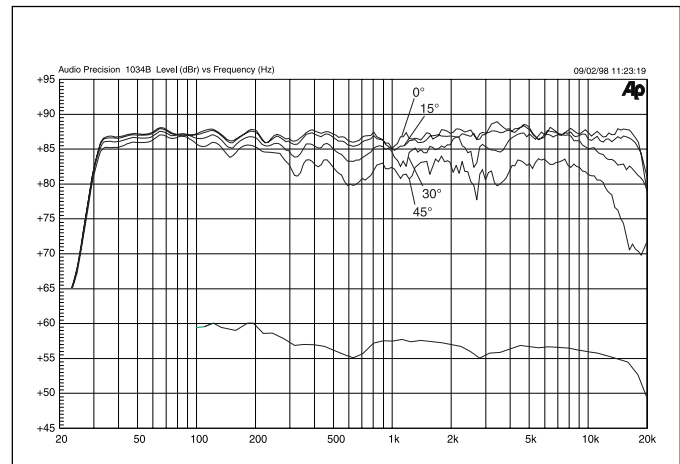
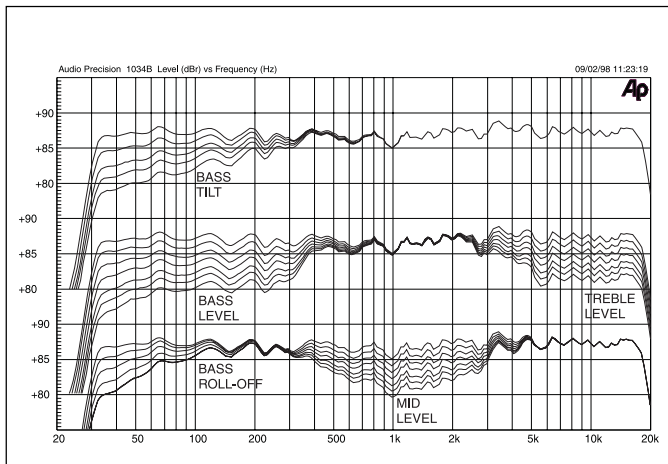

Fig 9. The above curves illustrates the effect of the 'bass tilt', 'bass roll-off' and 'bass', 'mid' and 'treble' level controls on the free field response, measured at 2 m.

Fig 10. The upper curve group shows the horizontal directivity characteristics of the 1034B in its horizontal configuration measured at 2m. The lower curve is a 1/6 octave power response measurement, derived from 144 directivity measurements.

SYSTEM SPECIFICATIONS

Lower cut-off frequency, -3 dB: ≤ 32 Hz
 Upper cut-off frequency, -3 dB: ≥ 20 kHz

Free field frequency response of system:
 33 Hz - 20 kHz (± 2.5 dB)

Maximum short term sine wave acoustic output on axis in half space, averaged from 100 Hz to 3 kHz: @ 1m ≥ 123 dB SPL

Maximum long term RMS acoustic output in same conditions with IEC-weighted noise (limited by driver unit protection circuit):
 @ 1m ≥ 118 dB SPL

Maximum peak acoustic output per pair @ 2m from the engineer with music material:
 ≥ 125 dB

Self generated noise level in free field @ 2m on axis:
 ≤ 15 dB(A)

Harmonic distortion at 100 dB SPL @ 1m on axis:
 Freq: 50...200 Hz $< 1\%$
 200...10k Hz $< 0.5\%$

Drivers:
 Bass 2 x 305 mm (12") cone
 Mid 1 x 130 mm (5") cone
 Treble 1 x 25 mm (1") metal dome

Weight: Speaker 73 Kg (161 lb)
 Amplifier 30 Kg (66 lb)

Speaker dimensions (Horizontal mounting):
 Height 700 mm (27⁹/₁₆")
 Width 890 mm (35")
 Depth 383 mm (15")*

Amplifier dimensions:
 Height 310 mm (12³/₁₆")
 Width 483 mm (19")
 Depth 250 mm (9¹³/₁₆")*

*Note that the cable connectors require additional 100 mm (4") of space behind both the amplifier and the speaker cabinet

AMPLIFIER SECTION

Bass amplifier output power with an 8 Ohm load:
 Short term 2 x 400 W

Mid amplifier output power with a 8 Ohm load:
 Short term 350 W

Treble amplifier output power with an 8 Ohm load:
 Short term 120 W

Long term output power is limited by driver unit protection circuitry.

Slew rate: 80 V/ μ s

Amplifier system distortion at nominal output:
 THD $\leq 0.05\%$
 SMPTE-IM $\leq 0.05\%$
 CCIF-IM $\leq 0.05\%$
 DIM 100 $\leq 0.05\%$

Signal to Noise ratio, referred to full output:
 Bass ≥ 100 dB
 Mid ≥ 100 dB
 Treble ≥ 100 dB

Mains voltage: 100/200 or 115/230V

Voltage operating range at
 230V setting: 207 - 244 V (-10/+6 %)
 115V setting: 104 - 122 V (-10/+6 %)

Power consumption:
 Idle 70 W
 Full output 1000 W

CROSSOVER SECTION

Input connector: XLR female pin 1 gnd
 pin 2 +
 pin 3 -

Input impedance: 10 kOhm balanced

Input level for 100 dB SPL output @ 1m:
 variable from +6 to -6 dBu

Input level for maximum short term output of 126 dB SPL @ 1m:
 variable from +32 to +20 dBu

Subsonic filter below 27 Hz :
 18 dB/octave

Ultrasonic filter above 22 kHz:
 12 dB/octave

Crossover frequencies:
 Bass/Mid 400 Hz
 Mid/Treble 3.2 kHz

Crossover acoustical slopes:
 > 24 dB/octave

Level control operating range in 1 dB steps:
 Bass from 0 to -6 dB & MUTE
 Mid from 0 to -6 dB & MUTE
 Treble from 0 to -6 dB & MUTE

Bass roll-off control in 2 dB steps:
 from 0 to -8 dB @ 29 Hz

Bass tilt control operating range in 2 dB steps:
 from 0 to -8 dB @ 50 Hz

The 'CAL' position is with all tone controls set to 'off' and input sensitivity control to maximum and corresponds to a maximally flat free field response.

GENELEC®

Genelec Oy, Olvitie 5
 FIN - 74100 IISALMI, FINLAND
 Phone: +358 17 813311
 Telefax: +358 17 812267
 E-mail: genelec@genelec.com
 Web: http://www.genelec.com

G

Genelec Document DR34001
 COPYRIGHT GENELEC OY 1998
 All data subject to change without prior notice