

Genelec 1035B
Control Room Monitoring System



Genelec 1035B Control Room Monitoring System



20th Century Fox Newman Scoring Stage, Hollywood

APPLICATIONS

Main Monitor For Large Control Rooms

SYSTEM

The Genelec 1035B is an extremely powerful monitor system, designed for large control rooms. It consists of a 600 liters (21 cu. ft.) speaker enclosure and a 19" electronics rack, which contains active crossovers, three channel power amplifiers and sophisticated protection and diagnostic circuitry. The speakers are designed for flush mounting in the control room wall, although they may be used free standing and can produce peak sound pressure levels in excess of 136 dB.

Bass, midrange and treble controls are included to allow the speakers to be matched to the acoustic conditions in different control rooms. The sensitivity of the system to its environment is minimized by the unique Directivity Control Waveguide (DCW) Technology, which provides excellent stereo imaging and frequency balance even in difficult acoustic situations. The system can be used in both vertical and horizontal orientations by simply rotating the DCW unit.

PROTECTION CIRCUITRY

The Audio Processing Unit (APU) which contains the crossover, also contains diagnostic and protection circuits. These monitor the amplifier channels for each driver and will automatically reduce the monitor's input gain, to protect a driver from overload and distortion. Reducing the gain of the entire monitor, rather than just that

of the overloaded channel, preserves its frequency balance. The protection circuitry also guards against DC, shorting and excessive temperature, and will take appropriate action to prevent damage. LED displays show the system's condition in detail on the APU front panel and in summarized form on the loudspeaker enclosure.

AMPLIFIERS

The bass, midrange and treble amplifiers produce 2 x 1100, 1 x 600 and 1 x 300 watts of short term power, respectively, with very low harmonic and inter-modulation distortion. The electronics have been carefully designed to ensure the highest subjective sound quality currently possible. Thermal protection is provided for the amplifiers. A standard 5 m, 10 core cable is supplied for the speaker connection. Longer lengths are available on application.

DRIVERS

Bass frequencies are reproduced by two long throw 385 mm (15") woofers in a vented, dual chamber configuration giving a frequency response extending down to 20 Hz, with the -3 dB point at 29 Hz.

The mid range frequencies are reproduced by two 130 mm (5") high sensitivity direct radiating cone drivers and the high frequency driver is a 25 mm (1") throat compression driver, with an upper -3 dB point at 22 kHz.

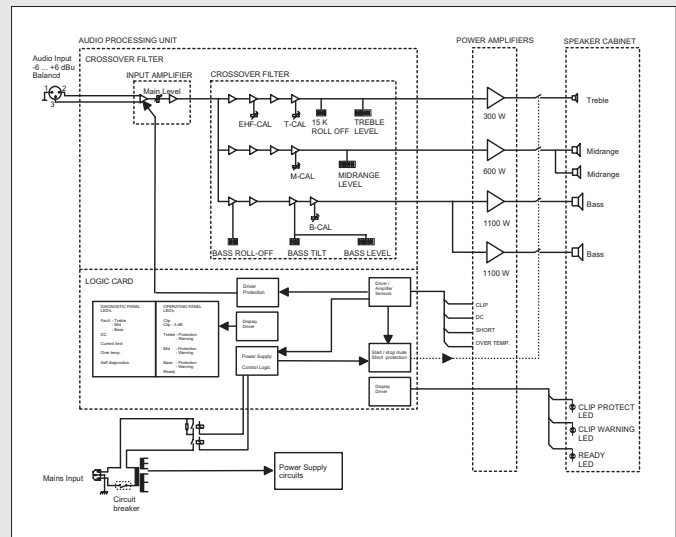

The block diagram showing active crossover filters, power amplifiers and driver units.

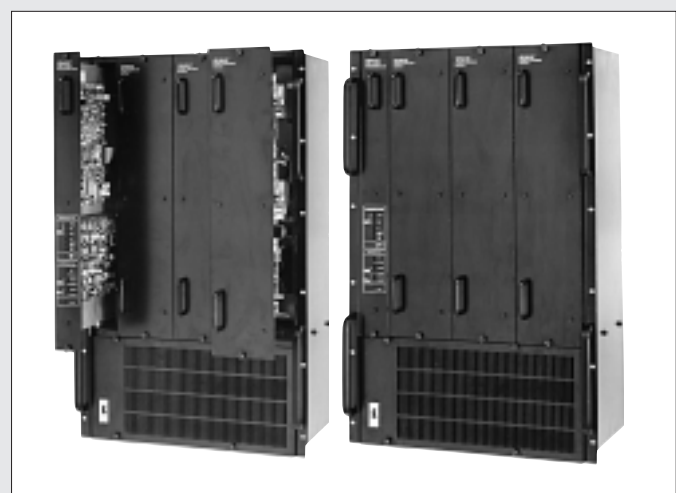

The rack mounting amplifiers, with Audio Processing Units.



Vertical mounting



Horizontal mounting

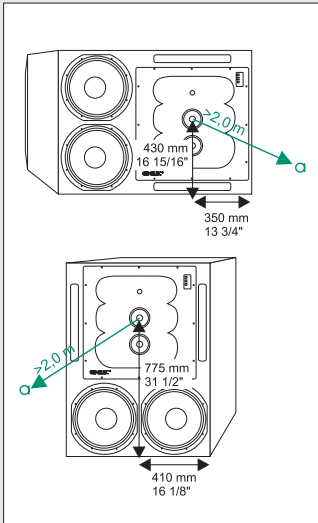

The reference axis lies on the upper midrange driver axis.

The mid and high frequency drivers have field replaceable diaphragms and are mounted in a DCW.

SOFFIT MOUNTING

Soffit (flush) mounting of a loudspeaker removes problems caused by diffraction effects and reflections from the wall behind it: Diffraction of sound at the loudspeaker cabinet edges degrades the transient response and directional properties, while reflections will cause interference, potentially leading to large dips in the frequency response. The use of DCW Technology reduces these effects to a large extent and the 1035B has versatile crossover controls to compensate for variations due to different speaker positioning. This allows it to be used either soffit mounted or as a free standing unit without using external equalization, although soffit mounting is recommended.

CROSSOVER FILTERS

The active crossover network consists of three parallel band pass filters, with crossover frequencies at 400 Hz and 3.5 kHz, and a common balanced input stage. All the filters are aligned for equal phase and group delay characteristics and are acoustically complementary. The filter slopes are 24 dB/octave.

To adjust the balance of the drivers to suit a particular acoustic environment, bass midrange and treble controls are included, which adjust the output in 1 dB steps. In addition, a 15 kHz 'roll-off' control and low frequency roll-off and 'tilt' controls are present, to allow further refinement of the system response.

DCW TECHNOLOGY

The revolutionary Directivity Control Waveguide Technology is a means of greatly improving the performance of a direct radiating multiway loudspeaker under normal listening conditions. One of the basic ideas is to match the performance of the drivers in terms of both frequency response and directivity. This results in smoother frequency response both on and off axis. Also, due to improved directivity control, especially in the midrange frequencies, more direct sound and less reflected sound is received at the listening position.

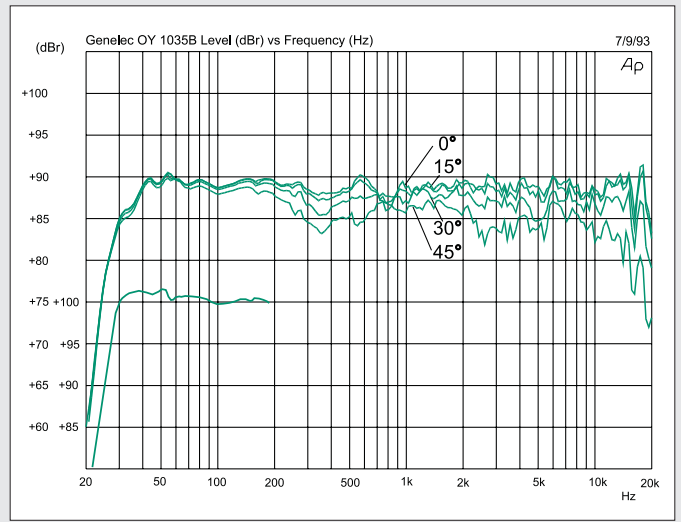

The upper curve group shows the horizontal directivity characteristics of 1035B in its vertical configuration measured at 2 m. The lower curve shows the low frequency response measured at 0.5 m.

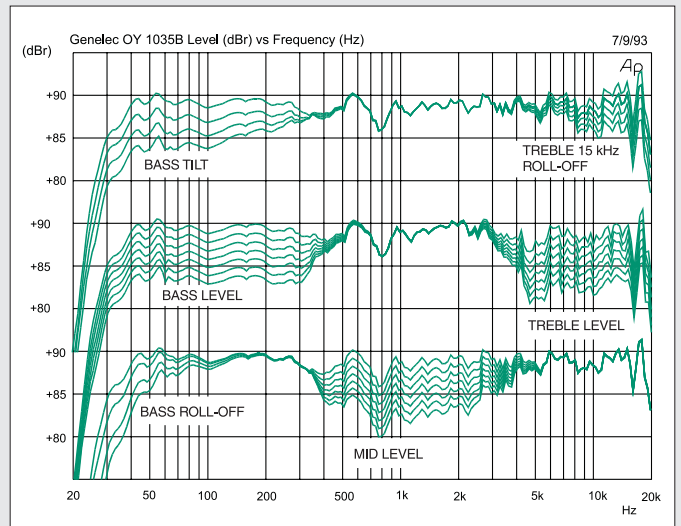

The curves above show the effect of the bass, mid and treble level controls, 15 kHz roll-off control and the bass tilt and roll-off controls on the free field response, measured at 2 m.

This gives improved stereo imaging and ensures the system is less sensitive to differing control room acoustics than any conventional direct radiator design. The DCW Technology improves the drive unit sensitivity by +2 to +6 dB thus increasing the system maximum sound pressure level.



The high and mid frequency drivers are mounted in a DCW to match their dispersion characteristics. The DCW may be rotated for horizontal or vertical mounting.



Calibrated crossover control switches. MUTE disconnects the channel for testing.

SYSTEM SPECIFICATIONS

Lower cut-off frequency, -3 dB:	≤ 29 Hz
Upper cut-off frequency, -3 dB:	≥ 22 kHz
Free field frequency response of system:	31 Hz - 20 kHz (± 2.5 dB)
Maximum short term sine wave acoustic output on axis in half space, averaged from 100 Hz to 3 kHz:	@ 1m ≥ 131 dB SPL
Maximum long term RMS acoustic output in same conditions with IEC-weighted noise (limited by driver unit protection circuit):	@ 1m ≥ 126 dB SPL
Maximum peak acoustic output per pair @ 2 m from the engineer with music material:	≥ 136 dB
Self generated noise level in free field @ 2m on axis:	≤ 20 dBA
Harmonic distortion at 100 dB SPL @ 1m on axis:	
Freq: 50...200 Hz	<1%
200...4k Hz	<0.5%
> 4 kHz	<3%
Drivers:	
Bass	2 x 385 mm (15") cone
Mid	2 x 120 mm (5") cone
Treble	1 x 25 mm (1") compression driver
Weight:	
Speaker	142 kg (313 lb)
Amplifier	71 kg (156 lb)
Speaker dimensions (Horizontal mounting):	
Height	820 mm (32 5/16")
Width	1105 mm (43 1/2")
Depth	775 mm (30 1/2")
Amplifier dimensions:	
Height	755 mm (29 3/4")
Width	483 mm (19")
Depth	370 mm (14 9/16")

AMPLIFIER SECTION

Bass amplifier output power with an 8 Ohm load:	
Short term	2 x 1100 W
Mid amplifier output power with a 4 Ohm load:	
Short term	600 W
Treble amplifier output power with an 8 Ohm load:	
Short term	300 W
Long term output power is limited by driver unit protection circuitry.	
Slew rate:	100 V/μs
Amplifier system distortion at nominal output:	
THD	≤0.05%
SMPTE-IM	≤0.05%
CCIF-IM	≤0.05%
DIM 100	≤0.05%
Signal to Noise ratio, referred to full output:	
Bass	≥101 dB
Mid	≥105 dB
Treble	≥106 dB
Mains voltage:	100/110/115/220/230/240V
Voltage operating range at	
230V setting:	219 - 241 V (±5%)
115V setting:	109 - 121 V (±5%)
Power consumption:	
Idle	150 W
Full output	3500 W

CROSSOVER SECTION

Input connector:	XLR female
	pin 1 gnd
	pin 2 +
	pin 3 -
Input impedance:	10 kOhm balanced
Input level for 110 dB SPL output @ 1m:	variable from +15 to -5 dBu
Input level for maximum short term output of 131 dB SPL @ 1m:	variable from +36 to +16 dBu
Subsonic filter below 27 Hz :	18 dB/octave
Ultrasonic filter above 22 kHz:	12 dB/octave
Crossover frequencies:	
Bass/Mid	400 Hz
Mid/Treble	3.5 kHz
Crossover acoustical slopes:	>24 dB/octave
Level control operating range in 1 dB steps:	
Bass:	from 0 to -6 dB & MUTE
Mid:	from 0 to -6 dB & MUTE
Treble:	from 0 to -6 dB & MUTE
Bass roll-off control in 2 dB steps:	from 0 to -8 dB @ 30 Hz
Bass tilt control operating range in 2 dB steps:	from 0 to -8 dB @ 50 Hz
Treble roll-off control operating range in 1 dB steps:	from +1 to -3 dB @ 15 kHz
The 'CAL' position is with all tone controls set to 'off' and input sensitivity control to maximum and corresponds to a maximally flat free field response.	

All data subject to change without prior notice.