



USER MANUAL

HYGENIQ CLEAN AIR FOGGER

Effortless 360° cleaning

Model: HYGENIQ CLEAN AIR FOGGER^{1.0}
Product code: E150004
Date: 11/12/2020
Version: B

HYGENIQ
Lenteweg 15, 7532 RV Enschede, The Netherlands
+31(0)53 428 28 60
info@hygeniq.com
www.hygeniq.com



PREFACE

Thank you for purchasing the HYGENIQ CLEAN AIR FOGGER^{1.0}. The powerful easy to use system can remove the negative effect from the air in seconds. It also makes cleaning surfaces much more effective when combined with the approved HYGENIQ CLEAN AIR Mist. Due to the 24V Li-ion battery and refillable tank, you can keep cleaning for as long as you wish. Please read the user manual carefully and become familiar with the operation and maintenance procedures. Store the manual in a safe place.

Content

PREFACE.....	2
Packing List.....	4
Safety Instructions	5
Product Description	6
Setup	9
Operation	11
Maintenance	133

Packing List



1 x HYGENIQ CLEAN AIR FOGGER

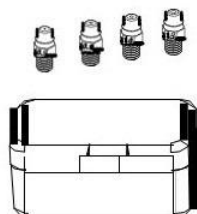

1 x Spray nozzle 3 x 0.3 mm

1 x Spray nozzle 0.5 mm

1 x Spray nozzle 0.8 mm

1 x Spray nozzle 1.0 mm

1 x Small tool box



1 x 6mm inner hexagon screw driver



1 x Battery

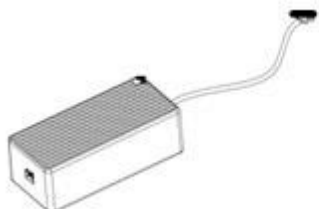



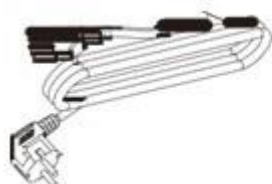

1 x Charger



1 x Power cable

Safety Instructions

The following symbols and terms are used throughout this manual and on the machine to alert the reader to safety issues and important information:

Symbol	Term	Explanation
	WARNING	Indicates a hazardous situation which, if the safety instructions are not followed, can lead to injuries of the operator or bystanders, light and/or moderate damage to the product or the environment.
	STRONG MAGNET	Indicates the machine contains strong magnets. These can cause pacemakers to stop as well as cause damage to electronic data, for instance on information stored on access passes.
	PACEMAKER	Indicates operators and maintenance crew wearing pacemakers should keep a minimal distance of 6 inch/ 15 cm. In this specific case operators may not use the machine as a backpack.
	BATTERIES	Indicates a battery operated machine. Batteries must be disposed of according to your local laws and regulations. It is advisable to fully charge the battery before use.

Read all instructions before using HYGENIQ CLEAN AIR FOGGER

Cautions when using the machine: 

Do not operate the machine without reading and fully understanding the instructions. If the machine is operated incorrectly it can pose a danger to the operator and others and will invalidate the manufactures warranty.

Before use please read and understand the following:

- A risk assessment for the works to be undertaken;
- MSDS Chemical Data sheet;
- Risk assessment for chemical use.

Keep the HYGENIQ CLEAN AIR FOGGER upright and securely fastened at all times while in use and during preparation and transportation.

Only use approved HYGENIQ CLEAN AIR Mist and batteries for safe use of this machine. Using other consumable items in the fogger invalidates the warranty and could lead to damage of the internal parts and could possibly pose a risk to the operator.

Maintenance/service people and operators with pacemakers need to keep a distance from the integrated magnets in the HYGENIQ CLEAN AIR FOGGER of 6 inch/15 cm whilst maintaining and operating the fogger.

Make sure the operator has been fully trained before using the machine.

Avoid fogging directly on humans and animals.

Ensure the machine is used in a dry environment, and do not allow water or any other liquid around the motor air inlet.

Product Description

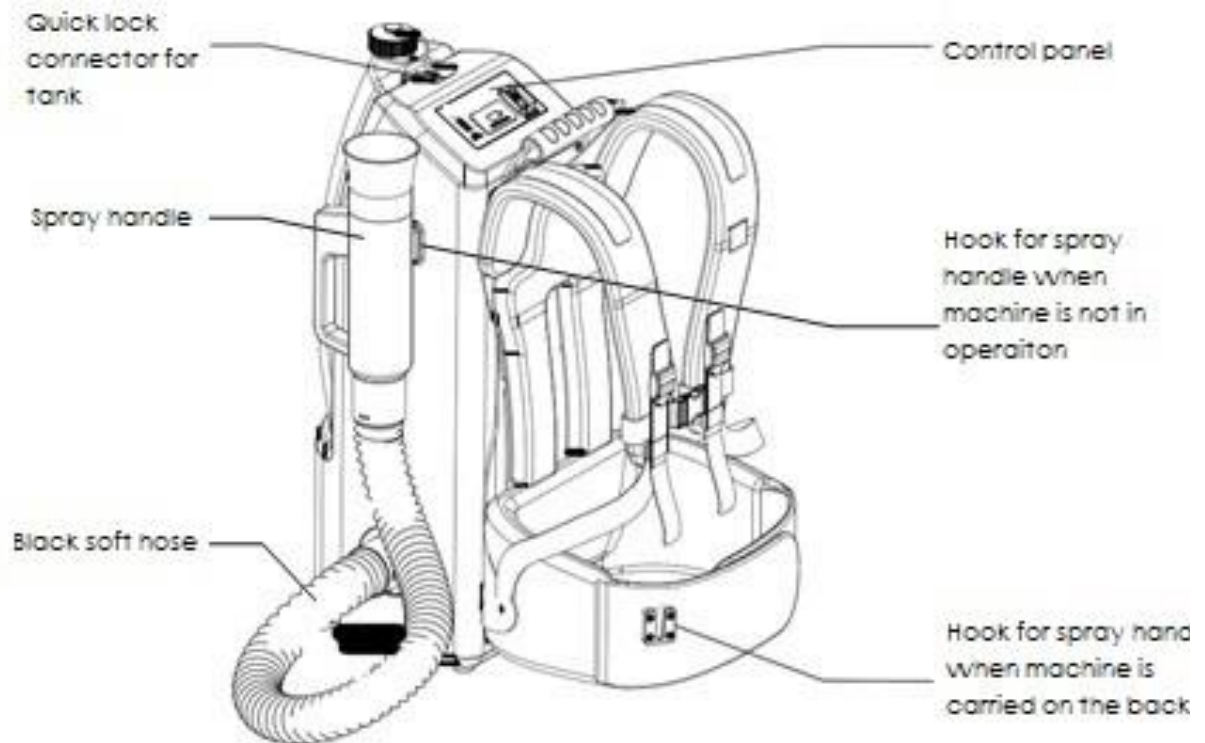
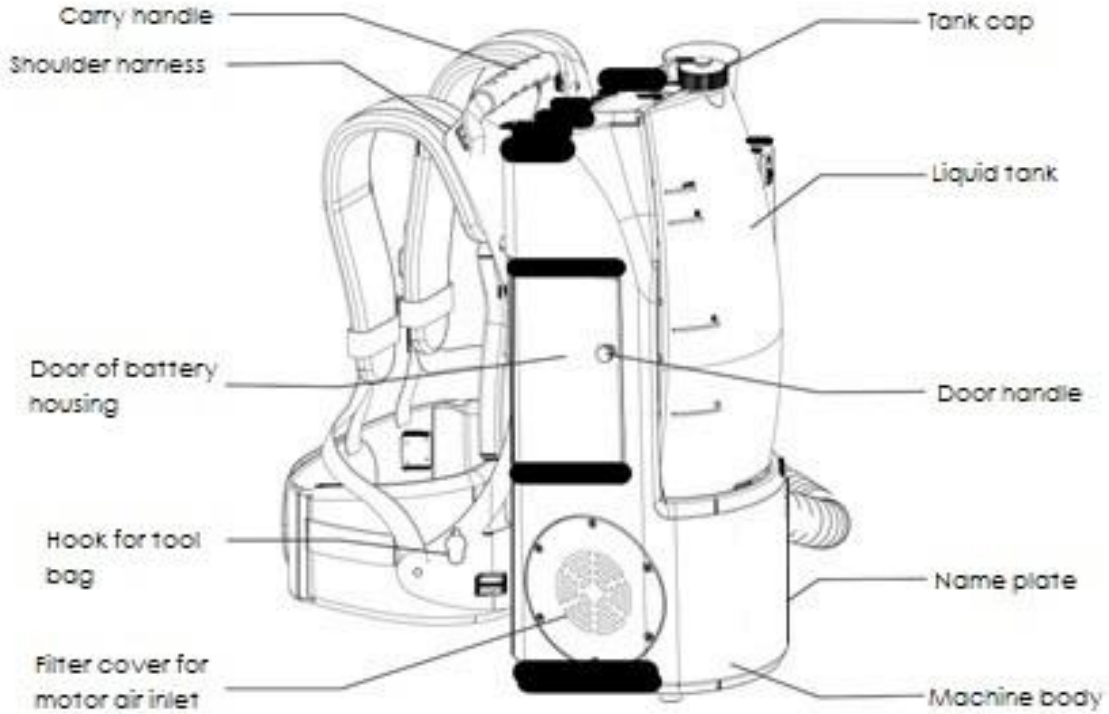

HYGENIQ CLEAN AIR FOGGER

Item	Specification
Product weight (W/O battery)	7.9KG
Product dimension	Main body: 200x595x225mm Included harness: 300x600x315mm
Tank capacity	3.5L
Battery weight	1.3KG
Battery voltage	DC24V
Duration of battery	1 Hour
Charger input voltage	AC100~250 Voltage
Charging time	1 Hours 50 minutes
Speed of spray	175~100ml/minutes
Hose length	1.2 meters
Droplet size	20~150µm
Spray nozzles	3 x 0.3mm, 0.5mm, 0.8mm, 1.0mm
Theoretical capacity per tank	12000m ³
Machine power	450W
Spray distance	5~6 meters
Pump	DC24V, 5W, 100ml/minute
Main body material	LDPE
Spray handle material	Aluminum

■ Control panel

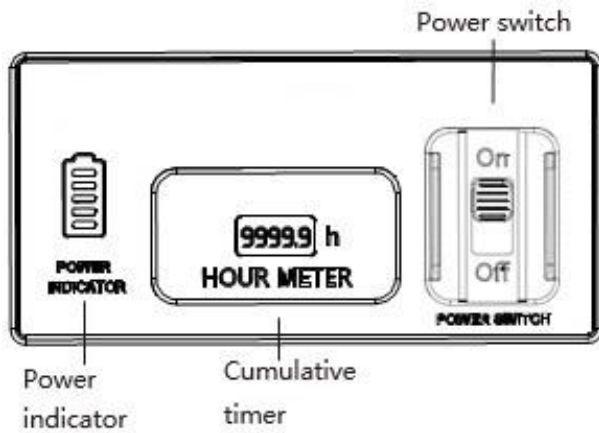

■ Power switch

- Power switch – slide to “On” position, the battery power turns on.
- Power switch – slide to “Off” position, the battery power turns off.

■ Cumulative timer

- 0.1 h Starting from 0.1h (6minutes)
- 9999.9 h to 9999.9h

■ Power indicator



■ Spray handle

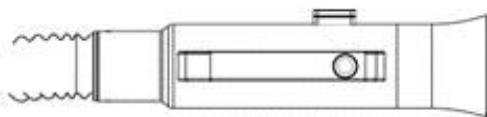

■ Trigger button of spray handle

- Press once, the spray nozzle starts fogging.
- Press again, the spray nozzle stops fogging.

The switch on spray handle is not a self-locking trigger button. When you press it once, the spray nozzle starts to fog. When you press it again, the fogging will stop. When the operator forgets to press the button to stop fogging, and turns off the machine with the power switch, the fogging will also stop. However, this is not recommended. Upon restarting the fogger, the default setting of the spray nozzle is off.

Setup

1. Charging the battery

For first time charge, please remove the yellow protector from the battery. Ensure that the battery has been fully charged before each operation.

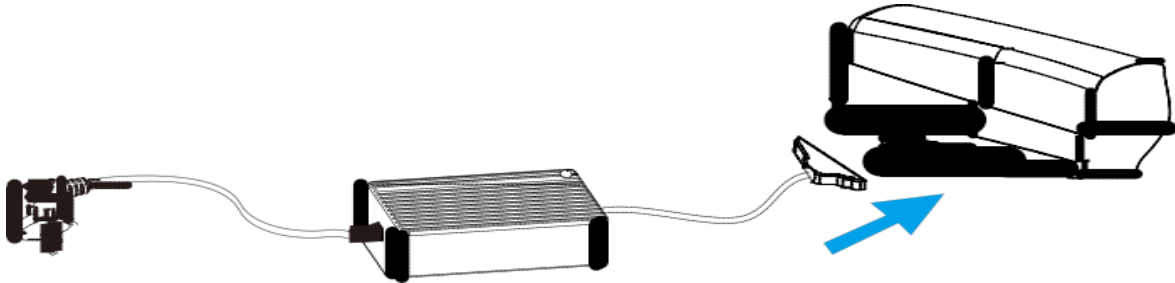

2. Fill the liquid tank

Place and secure the machine body upright. Unscrew the cap of the liquid tank, and pour the approved HYGENIQ CLEAN AIR Mist into the tank.

Or

Take the liquid tank from the machine, and secure it in a upright position. Unscrew the cap of the liquid tank, and pour the required amount of the approved HYGENIQ CLEAN AIR Mist into the tank. Insert the liquid tank back to the machine which should also be placed in an upright position. Note: 1L of HYGENIQ CLEAN AIR Mist covers approximately 3650 m³.

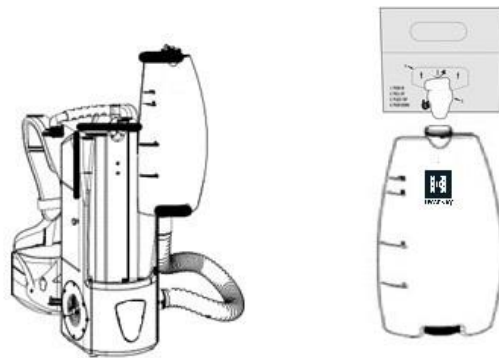

3. Insert the battery to the machine

Open the battery housing door, and slide the fully charged battery into the battery housing, until you hear a “click” sound. Make sure the battery is installed correctly and then close the door. To remove the battery, use the clamps on the sides of the battery to release.



HYGENIQ CLEAN AIR FOGGER

4. Installation of the nozzle in spray handle

Select the appropriate nozzle for the application.

Nozzle size	Droplet size	Spray distance	Duration (3.5L)	Application
3 x 0.3mm	~20µm	5~6m	35minutes	indoor
0.5mm	~30µm	5~6m	30minutes	indoor
0.8mm	~40µm	5~6m	25~30minutes	indoor
1.0mm	~60µm	5~6m	20~25minutes	outdoor

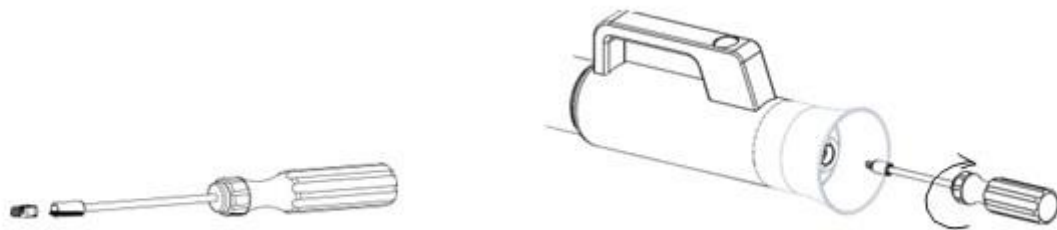

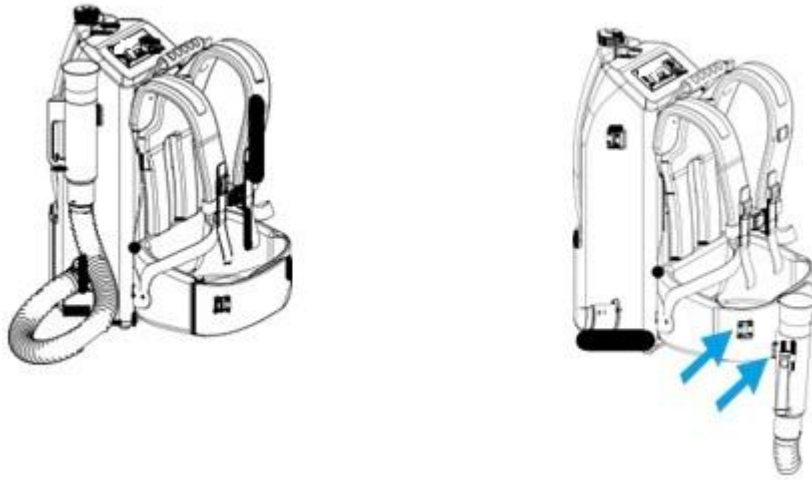

Operation

1. Place the machine body with filled tank on the table, and then place the spray nozzle on the lower hook.

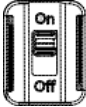

2. Turn the main switch to “on” before placing the fogger on your back and adjust the straps and the belt to the most optimal/comfortable operating position.
3. Spraying steps

Step 1 - Turning on the machine

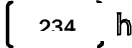
	Power switch – slide to “On” position.
	The power indicator will be illuminated.
	The cumulative timer displays the hours of operation up to the last usage.

Step 2 - Press the button, and start fogging

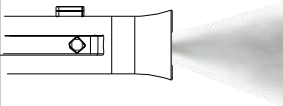
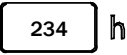
	Press the button once.
	The nozzle starts to fog.
	The cumulative timer starts.

Step 3 - Turning off the machine

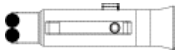
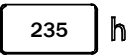
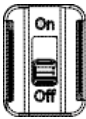
	Press the button again, the spray nozzle will stop fogging.
	
	The cumulative timer stops and the cumulative hours will be registered.
	Power Switch – slide to “Off” position, the battery power turns off.

HYGENIQ CLEAN AIR FOGGER

4. Additional information:

Preferably disperse the mist through the room as high as possible for an optimal effect. This is especially recommended for larger areas / rooms. The mist droplets agglomerate effectively with unwanted substances in the air, which then sink down and can no longer be inhaled. During this process, an invisible screen is created that purifies the air from top to bottom.

HYGENIQ CLEAN AIR MIST can also be used to clean surfaces. Wipe clean the surfaces after spraying of the mist on the targeted objects. Specific 'risk points' such as door handles, light switches and other touch points or contact surfaces can be targeted directly to ensure optimal hygiene. Use MIST regularly for optimal hygienic results.

Maintenance

The fogger needs to be maintained during normal use:

1. Empty the liquid tank after each use, and rinse the tank and the hose with clean water;
2. Charge the battery fully after each use;
3. It is best not to exceed 4 hours of continuous use;
4. Ensure the machine is always used upright and in a dry environment, and do not allow water or any other liquid around the motor air inlet.



5. Spray nozzles need to be stored in the small tool box, together with the screw driver. The tool box can be hooked on to the backpack harness spring hook (3 nozzles in the tool box and 1 in the spray handle).

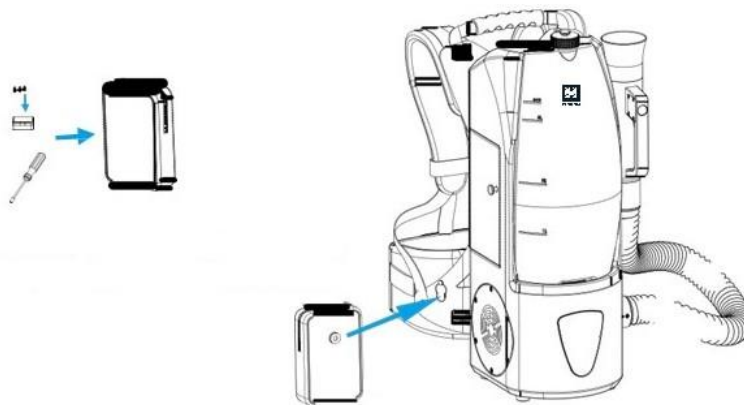

6. If there is any issue with your fogger please contact HYGENIQ.