

Dose and Position Sensing Transmission Ionization Chamber for Flash Therapy Applications

Features

- 16 cm x 16 cm sensitive area
- Ionization chamber with 64 by 64 strip readout electrodes or position and shape tracking
- Dual gap integral dose section
- Small electrode gaps for high beam current operation
- Small insertion length (51 mm)
- Very low scattering
- Radiation-hard Kapton™ thin film electrode foils with gold patterning
- Precision laser-cut electrode foils
- Operable with atmospheric pressure air chamber gas or flow-through gas
- Integrated internal temperature, pressure and humidity sensing
- Integrated desiccant for fill gas
- High voltage sense loopback



Applications

- Particle therapy scanned beam tracking and dosimetry
- Pencil beam scanning control
- Flash therapy research
- General high energy ion beam diagnostics

Specifications

Beam compatibility	
Species	Protons, deuterons, fully-stripped carbon
Energy range	30 MeV/nucleon to 500 MeV / nucleon
Beam current density range	Up to 1 $\mu\text{A cm}^{-2}$ DC >= 10 $\mu\text{A cm}^{-2}$ low duty-cycle pulsed beams
Sensor	
Type	Parallel plate ionization chamber with multistrip electrodes for position readout and independent integral plane section.
High voltage bias	500 V nominal, maximum recommended 800 V
Sensitive area	160 mm by 160 mm



Sensor (cont)	
Sensitive volume	Active volume 1: Integral dose. 1mm. Active volume 2: Integral dose. 1mm. Active volume 3: Position readout 1 (strip electrode). 3mm. Active volume 4: Position readout 2 (strip electrode). 3mm.
Strip geometry	64 strips 2.50 mm pitch (150 μ m inter-strip gaps typical)
Gain uniformity	Integral section better than +/-2.5 % for beams within the sensitive area.
Position accuracy	Integral linearity better than 250 μ m maximum deviation relative over the sensitive area.
Position resolution	Depends on signal to noise ratio; 10's of μ m beam centroid position typically achievable with good signal.
Fiducials	Electrode strips tolerance build-up relative to fiducial features on body +/- 0.3 mm nominal, < +/- 0.2 mm typical .

Chamber gas	
Operating gas	Dry atmospheric air, or flow of any clean ionization chamber gas (N ₂ , Ar/ CO ₂ etc).
Flow gas connections	To suit 1/8" od tube push fit
Desiccant	Mandatory when chamber is closed to atmosphere. Silca gel sachets (3). Sachets can be changed with chamber in situ.

Mechanical	
Insertion length	44 mm window to window, 50.7 mm housing face to face.
Overall size	330 mm by 330 mm by 78 mm approx (see figures)
Weight	3.8 kg (8 lb) excluding any added mounting brackets.
Operating environment	Clean and dust-free, 0 to 35 C (15 to 25 C recommended , < 70% humidity, non-condensing, vibration < 0.1g all axes (1 to 50 Hz) Temperature and pressure compensation of chamber gain must be performed for accurate gain. Avoid loud audio in 50 - 300 Hz range during operation to prevent microphonic effects.
Shipping and storage environment	-10 to 50 C, < 80% humidity, non-condensing, vibration < 1g all axes, 1 to 20 Hz



Beam scattering

Layers in beam path

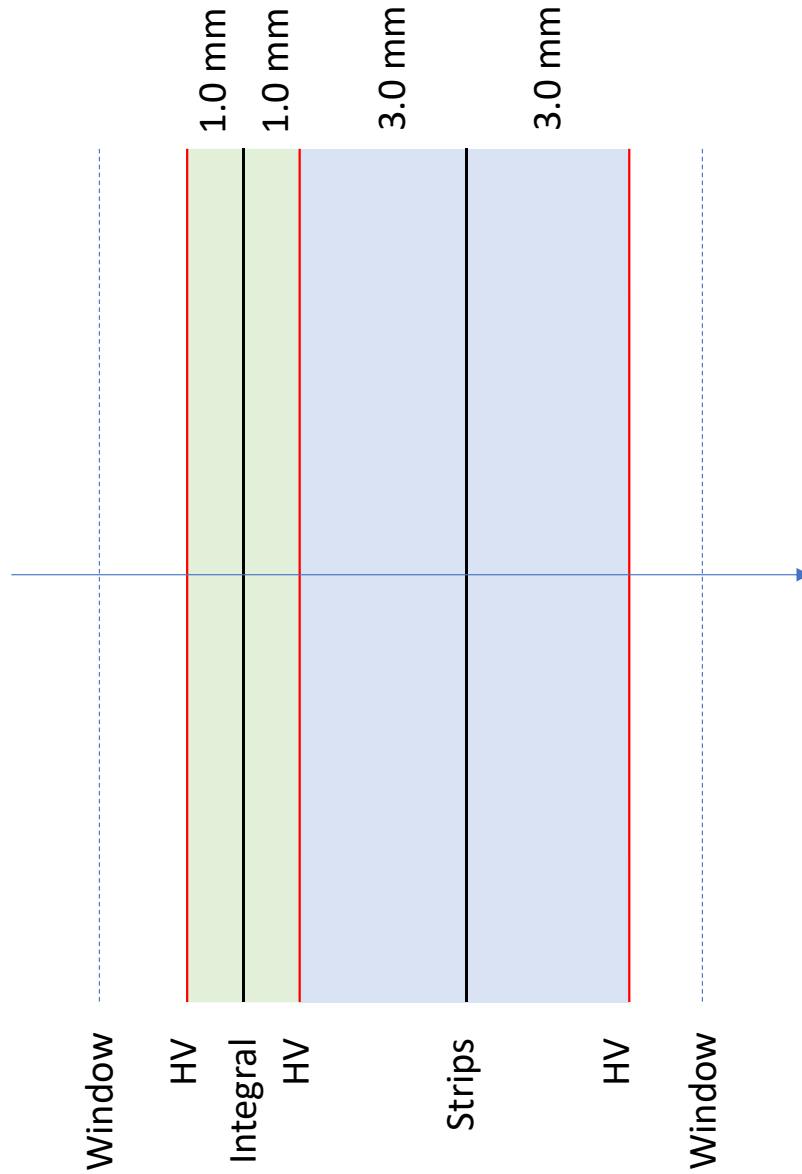

Materials in beampath

Air	43.9 mm
Kapton™	77.5 μm
Aluminium	1.0 μm
Gold	0.16 μm

Total effective thickness 170 μm water equivalent.



Connectors

Strip readout

Two Centronics VHDCI 68 way receptacle (SCPI-style) for strip current signals. Gold-plated contacts. Mating connector Molex VHDCI 0.8MM plug. Strain relief tie-downs provided.
 VHDCI # 1 axis A / VHDCI #2 axis B

Top row				Bottom row			
1	Gnd	18	Strip 16	35	Gnd	52	Strip 48
2	Strip 32	19	Strip 15	36	Strip 64	53	Strip 46
3	Strip 31	20	Strip 14	37	Strip 63	54	Strip 46
4	Strip 30	21	Strip 13	38	Strip 62	55	Strip 45
5	Strip 29	22	Strip 12	39	Strip 61	56	Strip 44
6	Strip 28	23	Strip 11	40	Strip 60	57	Strip 43
7	Strip 27	24	Strip 10	41	Strip 59	58	Strip 42
8	Strip 26	25	Strip 09	42	Strip 58	59	Strip 41
9	Strip 25	26	Strip 08	43	Strip 57	60	Strip 40
10	Strip 24	27	Strip 07	44	Strip 56	61	Strip 39
11	Strip 23	28	Strip 06	45	Strip 55	62	Strip 38
12	Strip 22	29	Strip 05	46	Strip 54	63	Strip 37
13	Strip 21	30	Strip 04	47	Strip 53	64	Strip 36
14	Strip 20	31	Strip 03	48	Strip 52	65	Strip 35
15	Strip 19	32	Strip 02	49	Strip 51	66	Strip 34
16	Strip 18	33	Strip 01	50	Strip 50	67	Strip 33
17	Strip 17	34	Shield	51	Strip 49	68	Shield

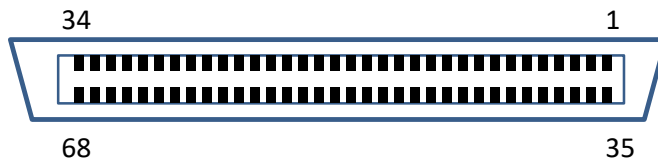

Connector shell is common with shield.
 When viewing schematic drawings, note that channels are numbered I0 to I63 on this connector..
 The pin arrangement is directly compatible with a pin to pin 68-way cable connection to an I128M electrometer. One axis will read out on I128M channels 1-64, the other on channels 65-128.

CAUTION



Do not expose the device to ionizing radiation beams unless all connections to readout electronics and bias supplies are made, or otherwise grounded. Charge build-up and subsequent arcing damage can occur.



Connectors (cont)																					
Integral dose	BNC Combined signal from the two integral section gaps.																				
HV in / out	SHV Pair of connectors for anode voltage (HV in / HV loopback out)																				
Monitor	DSub male 9-pin Two identical connectors with duplicate functions on two redundant identical sets of sensors. Electrically independent of electrode readouts. <table border="1" data-bbox="550 598 1219 844"><tr><td>1</td><td>Chassis</td><td>6</td><td>Analog out +</td></tr><tr><td>2</td><td>Analog out -</td><td>7</td><td>Signal select bit 0</td></tr><tr><td>3</td><td>Signal select bit 1</td><td>8</td><td>Device ID2</td></tr><tr><td>4</td><td>Device ID1</td><td>9</td><td>+5V in</td></tr><tr><td>5</td><td>DGnd</td><td></td><td></td></tr></table> Device ID for the I64-16SG is 2 (ID2 set).	1	Chassis	6	Analog out +	2	Analog out -	7	Signal select bit 0	3	Signal select bit 1	8	Device ID2	4	Device ID1	9	+5V in	5	DGnd		
1	Chassis	6	Analog out +																		
2	Analog out -	7	Signal select bit 0																		
3	Signal select bit 1	8	Device ID2																		
4	Device ID1	9	+5V in																		
5	DGnd																				



Calibration

Gain curves

Approximate gain curves at standard temperature and pressure for protons, dual 1 mm integral plane gaps and 3 mm strip readout gaps.

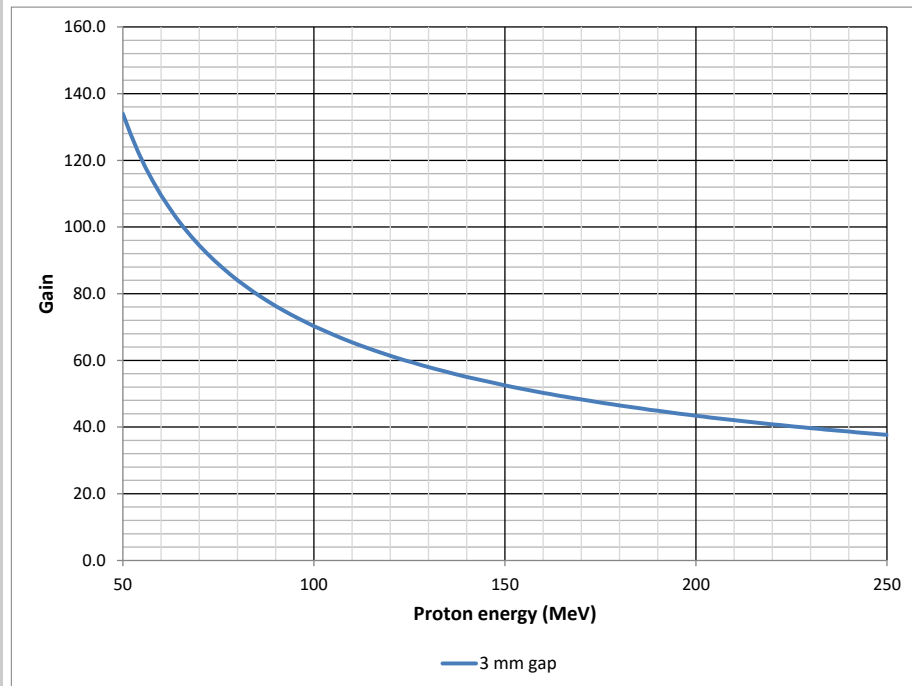
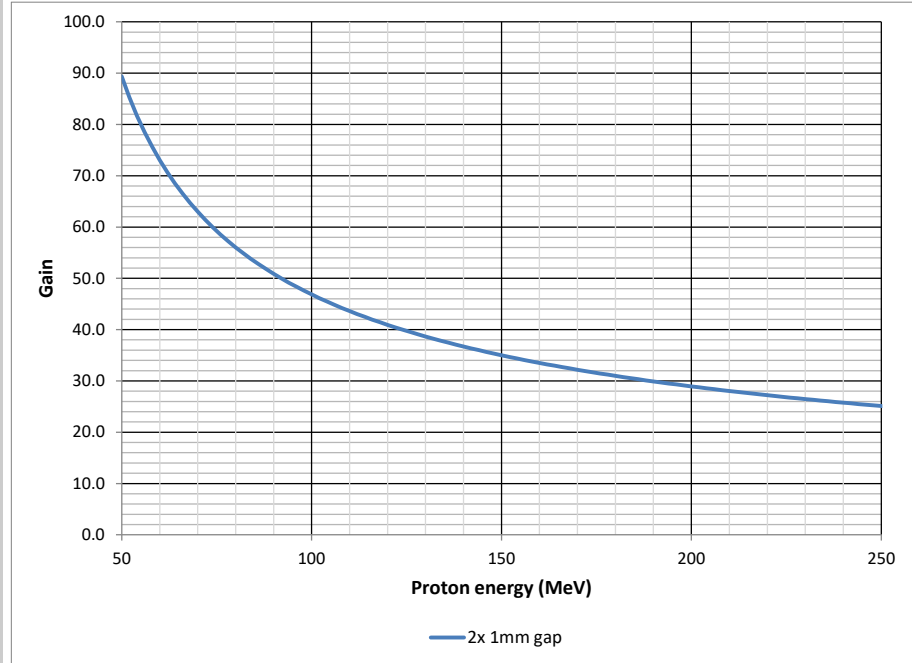

Note: Critical dosimetry measurements must use accurate gain values referenced to traceable standards, and regularly validated.



Calibration (cont)																
Environmental sensors readout MUX	<p>Digital bit pattern (TTL levels) to select analog sensor output voltage that is switched to pins 6, 2 of monitor connector.</p> <table border="1"> <thead> <tr> <th><i>Bit 1</i></th> <th><i>Bit 0</i></th> <th><i>Selected sensor</i></th> </tr> </thead> <tbody> <tr> <td>0</td> <td>0</td> <td>Temperature (V_{measT})</td> </tr> <tr> <td>0</td> <td>1</td> <td>Pressure (V_{measP})</td> </tr> <tr> <td>1</td> <td>0</td> <td>Relative humidity (V_{measH})</td> </tr> <tr> <td>1</td> <td>1</td> <td>Reference voltage (V_{ref})</td> </tr> </tbody> </table>	<i>Bit 1</i>	<i>Bit 0</i>	<i>Selected sensor</i>	0	0	Temperature (V_{measT})	0	1	Pressure (V_{measP})	1	0	Relative humidity (V_{measH})	1	1	Reference voltage (V_{ref})
<i>Bit 1</i>	<i>Bit 0</i>	<i>Selected sensor</i>														
0	0	Temperature (V_{measT})														
0	1	Pressure (V_{measP})														
1	0	Relative humidity (V_{measH})														
1	1	Reference voltage (V_{ref})														
Temperature	<p>Temperature(centigrade) = $100 * V_{measT}$ Temperature(Kelvin) = Temperature(centigrade) + 273.2</p>															
Pressure	<p>Pressure(psi) = $18.75 * (V_{measP} / V_{ref} - 0.1)$ Pressure(mbar) = Pressure(psi) * 68.95 Pressure(Pa) = Pressure(psi) * 6895</p>															
Humidity	<p>Relative humidity (%) = $157 * (V_{measH} / V_{ref}) - 23.8$</p>															
Gain correction	<p>Nominal gain at standard ambient temperature and pressure (Temperature_{SATP} = 298.15 K, Pressure_{SATP} = 100000 Pa), must be corrected for measured temperature and pressure:</p> <p>Gain = $1 / [Gain_{SATP} * (Pressure_{SATP} / Pressure(Pa)) * (Temperature(Kelvin) / Temperature_{SATP})]$</p> <p>For nominal gains established at other reference temperature and pressure, substitute the appropriate reference values in the equation.</p>															



Layout

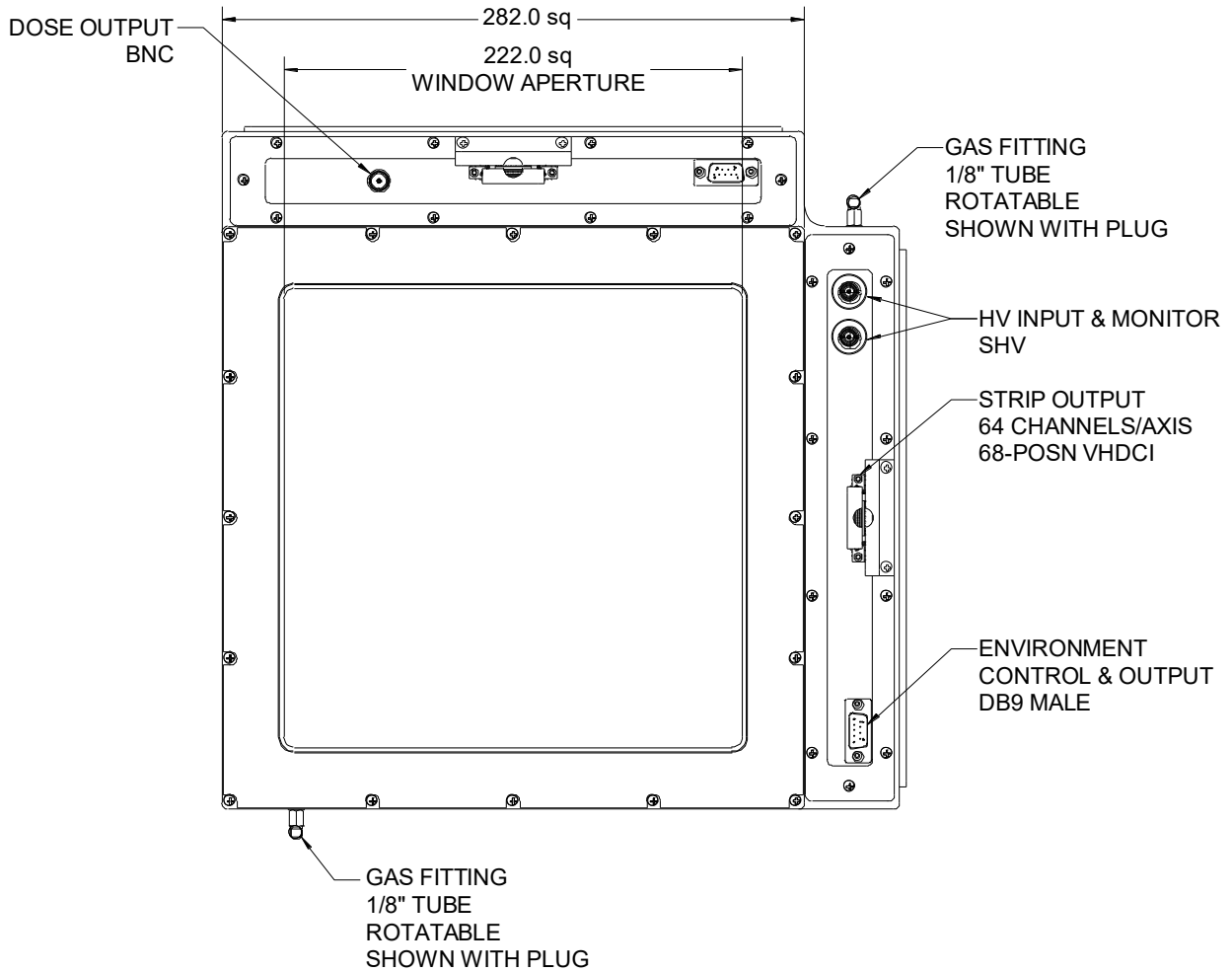

Designation of axes as X / Y, or horizontal / vertical is arbitrary, as it depends upon the orientation of the IC with respect to the beamline. Beam may enter from either direction, entrance face shown is arbitrary, but allows cables to be routed back along beamline.

Strips are numbered sequentially from the top left corner in the view shown, both axes.

A beam entering through this face passes through integral section gaps, the X sensing gap, the Y



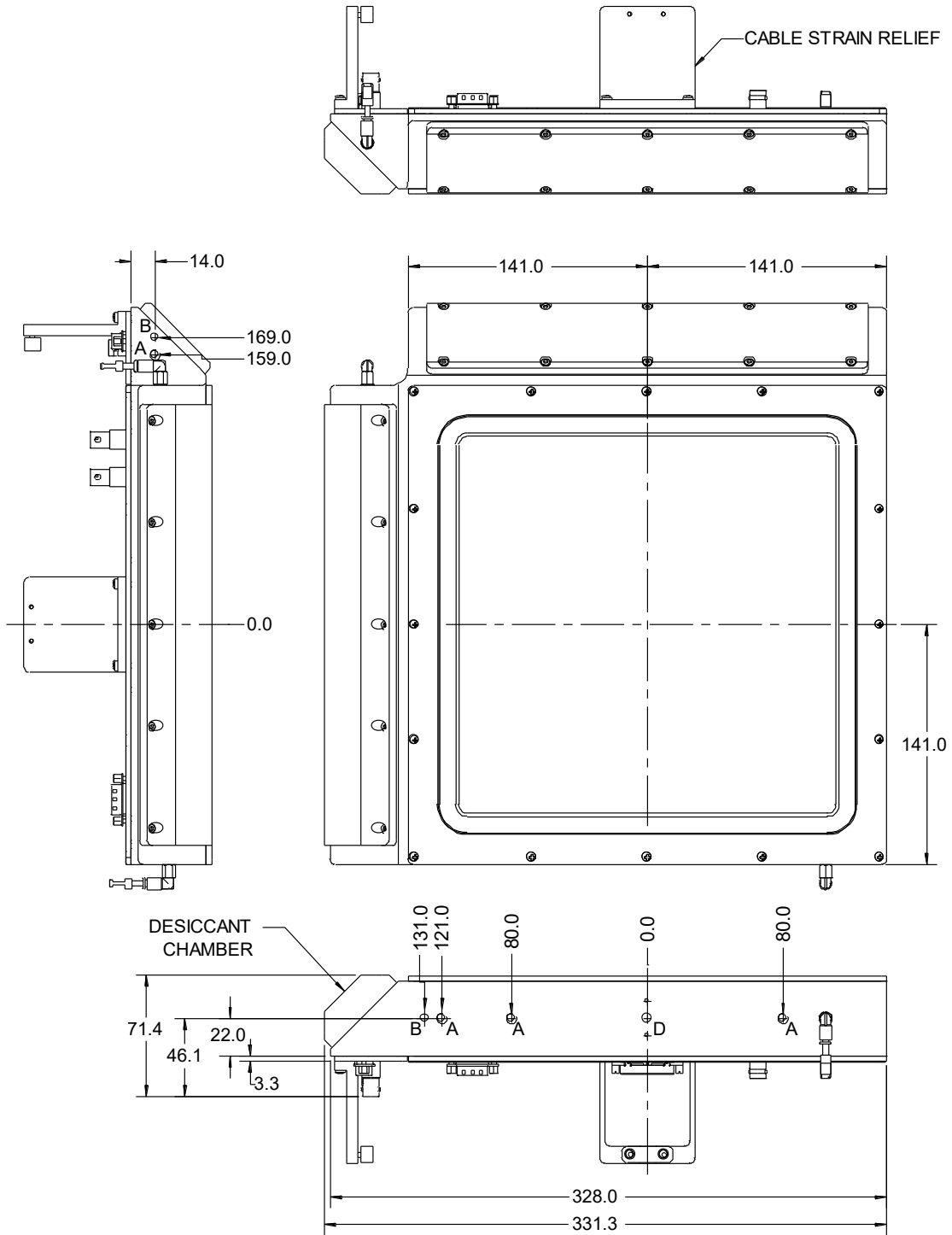

Dims mm



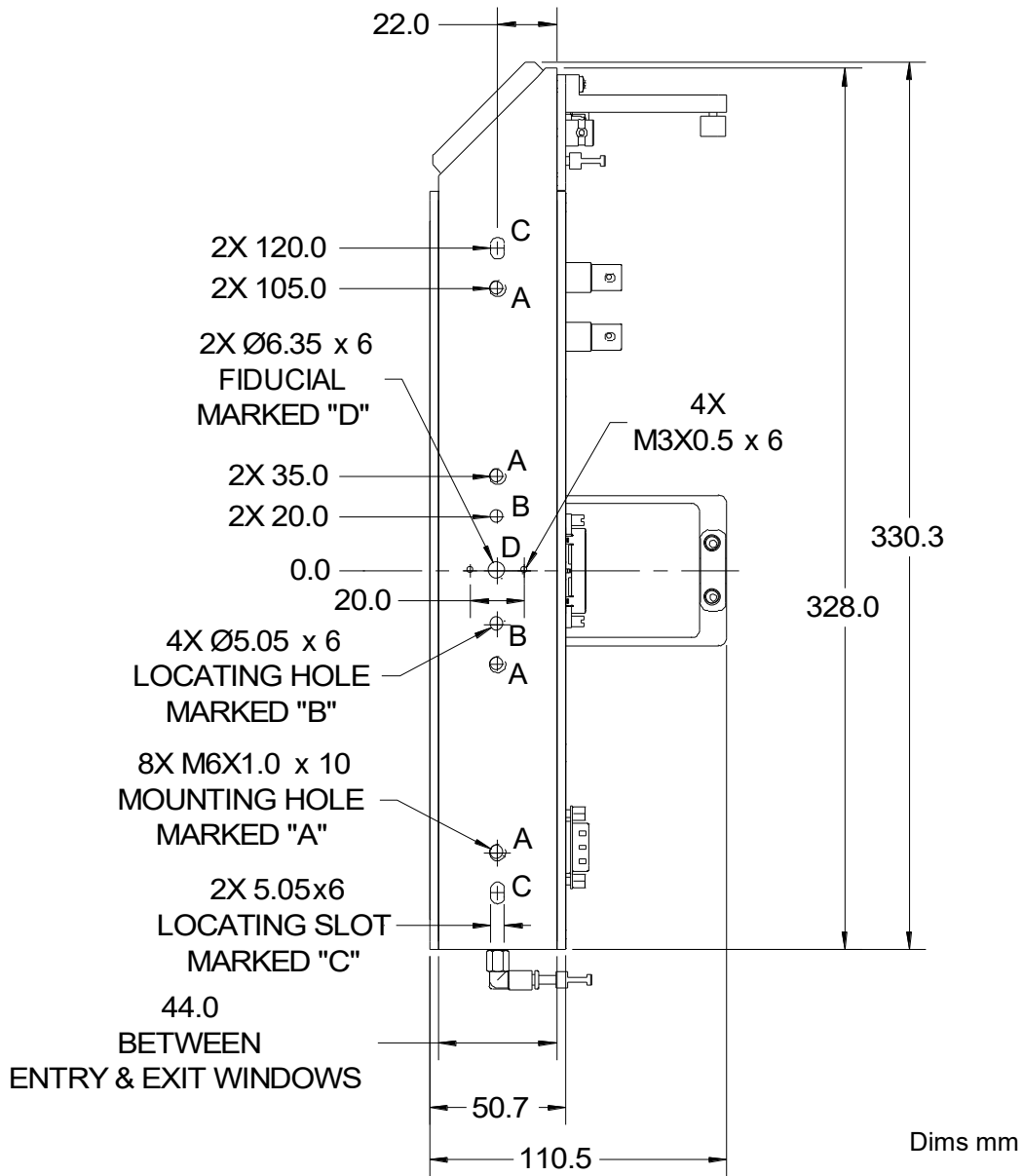

Ordering information

IC64-16SG	Ionization chamber small gap with 16 by 16 cm sensitive area, 64 by 64 strip position readout and dual gap integral plane integral dose readout.
IC64-16SG-SYS-20	IC64-16SG plus readout electronics and 20' (7.6 m) cables set.

Pyramid Technical Consultants, Inc.,
135 Beaver Street Suite 102
Waltham MA 02452 USA
Tel: +1 781 402 1700 (USA),
+44 1273 492002(UK)

Email: support@ptcusa.com

www.ptcusa.com

The information herein is believed accurate at time of publication, but no specific warranty is given regarding its use. All specifications are subject to change.

All trademarks and names acknowledged.

IC64-16SG_DS_260330

