

Dosimetry and Position Sensing Ionization Chamber for Ion Beam Tracking

Features

- 25 cm x 25 cm sensitive area
- Ionization chamber with dual gap integral plane readout for fast, low-noise dosimetry
- 128 by 128 strip readout for position and shape tracking
- Minimum scattering due to thin films of low-Z material
- Small insertion length
- Polyimide film electrode substrates for radiation hardness and high geometric precision
- Operable with atmospheric pressure air chamber gas or flow-through gas
- Integrated temperature, pressure and humidity sensing
- Integrated desiccant system for fill gas
- High voltage sense loopback
- Optimised for use with I128 readout electronics



Applications	<ul style="list-style-type: none"> • Particle therapy scanned beam tracking and dosimetry • Pencil beam scanning control • General high energy ion beam diagnostics
Options	<ul style="list-style-type: none"> • Gold metallization in place of aluminium for readout electrodes

Specifications

Beam compatibility	
Species	Protons, deuterons, fully-stripped carbon
Energy range	30 MeV /nucleon to 500 MeV / nucleon
Beam current density range	Up to 30 nA cm ⁻² (proton particle current) (Note that recombination losses must be qualified for a particular application)
Sensor	
Type	Parallel plate multi-layer ionization chamber assembly with multi-strip cathodes and dual gap integral plane cathode
High voltage bias	2000 V maximum
Sensitive area	250 mm by 250 mm



Specifications (continued)**Sensor (continued)**

Sensitive volume	Active volume 1: Dual 5 mm gap integral plane section Active volume 2: 7 mm gap Y(B) strip section Active volume 3: 7 mm gap X(A) strip section
------------------	---

Strip geometry	Equal width 1.89 mm on 2.00 mm pitch
----------------	--------------------------------------

Chamber gas

Operating gas	Atmospheric air, or flow of any clean ionization chamber gas (N ₂ , Ar/CO ₂ etc)
---------------	--

Flow gas connections	To suit 1/8" tube push fit
----------------------	----------------------------

Desiccant	For use when chamber is operated with air filling (not flow gas). Four silca gel sachets. Sachets can be changed with chamber in situ.
-----------	---

Mechanical

Insertion length	44 mm window to window, 50.4 mm body face to body face
------------------	--

Orientation	Operable in any orientation, and with beam entering in either direction
-------------	---

Overall size	416 mm by 416 mm by 80 mm (see figures)
--------------	---

Weight	5.0 kg (11 lb)
--------	-----------------

Operating environment	Clean and dust-free, Temperature 10 to 35 C (18 to 25 C recommended) , Humidity < 70%, non-condensing Vibration < 0.1g all axes (1 to 100 Hz) Ambient sound in < 300 Hz range should be minimised to prevent microphon-ic pickup
-----------------------	--

Shipping and storage environment	-10 to 50 C, < 80% humidity, non-condensing, vibration < 1g all axes, 1 to 100 Hz A specialized shipping container is included.
----------------------------------	--



Materials

Materials in beam path

1	12.5 μm polyimide window with 0.1 μm Al both sides
	11.5 mm fill gas
2	12.5 μm polyimide anode electrode with 0.1 μm Al both sides
	5.0 mm fill gas (active volume)
3	25 μm polyimide IP electrode with 0.1 μm Al both sides
	5.0 mm fill gas (active volume)
4	12.5 μm polyimide anode electrode with 0.1 μm Al both sides
	7.0mm fill gas (active volume for Y(B) strips)
5	25 μm polyimide cathode electrode with 0.1 μm Al both sides
	7.0 mm fill gas (active volume for X(A) strips)
6	12.5 μm anode electrode with 0.1 μm Al both sides
	7.5 mm fill gas
7	12.5 μm polyimide window with 0.1 μm Al both sides

Total effective thickness < 200 μm water equivalent based on proton energy loss, 50—250 MeV

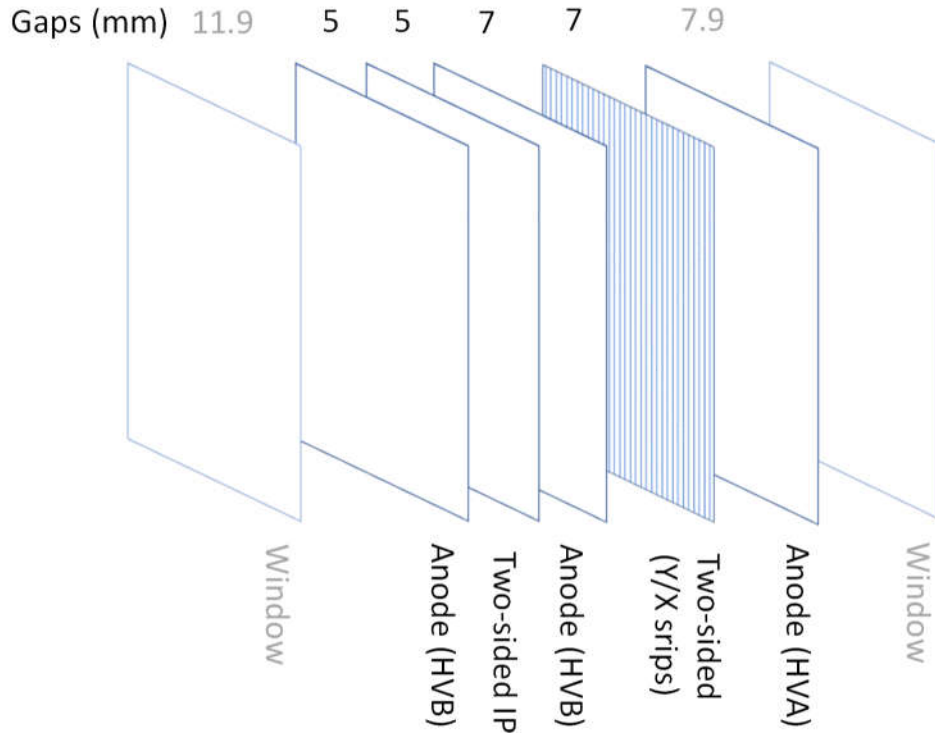

Connectors

Strip readout

High density DSub male 44 pin.
 Eight connectors color-coded (four per axis for strips Red 1-32, Green 33-64, Blue 65-96, White 97-128)

1	Strip 29 I_28	16	Strip 31 I_30	31	Strip 32 I_31
2	Strip 28 I_27	17	Strip 30 I_29	32	Shield
3	Strip 26 I_25	18	Strip 27 I_26	33	KGnd
4	Strip 24 I_23	19	Strip 25 I_24	34	KGnd
5	Strip 22 I_21	20	Strip 23 I_22	35	KGnd
6	Strip 20 I_19	21	Strip 21 I_20	36	KGnd
7	Strip 18 I_17	22	Strip 19 I_18	37	KGnd
8	Strip 16 I_15	23	Strip 17 I_16	38	KGnd
9	Strip 14 I_13	24	Strip 15 I_14	39	KGnd
10	Strip 12 I_11	25	Strip 13 I_12	40	KGnd
11	Strip 10 I_09	26	Strip 11 I_10	41	KGnd
12	Strip 8 I_07	27	Strip 9 I_08	42	KGnd
13	Strip 6 I_05	28	Strip 7 I_06	43	Shield
14	Strip 4 I_03	29	Strip 5 I_04	44	Strip 3 I_02
15	Strip 2 I_01	30	Strip 1 I_00		

The table shows the connections for the first bank of 32 signals for either axis (connector J1). The same connection pattern is repeated for the remaining three connectors on each axis:

J2: Strips 33 to 64 (I_33 to I_63)

J3: Strips 65 to 96 (I_64 to I_95)

J4: Strips 97 to 128 (I_96 to I_127).

I_xx numbers are circuit schematic references.

Integral plane readout

Lemo 0B four pin female

1	Signal current	4	Chassis
2	AGnd	3	Aux signal current

1 and 3 are connected internally

Ground plane connection

Lemo 0B four pin female.
 Fit shorting plug, pin 1 to pin 2.



Connectors (cont)

HV in / out

SHV

Four connectors for anode voltages

- two (HV in and HV sense out) for strip readout section
- two (HV in and HV sense out) for integral plane section

Monitor

DSub male 9-pin, two connectors with duplicate functions.

1	Chassis	6	Analog out +
2	Analog out -	7	Signal select bit 1
3	Signal select bit 2	8	Device ID bit 2
4	Device ID bit 1	9	Vref in (+5 V in)
5	DGnd		

Grounding

Multiple ground options that may be connected or isolated, depending on whether control and readout electronics (integral plane readout, strip readout, environmental sensor control and readout, high voltage bias) are integrated or independent.

AGnd is the primary signal reference ground. The guard areas on the integral and strip electrode planes are connected to AGnd.

KGnd is an auxiliary signal ground for strip readout electronics. Used if the strip readout electronics are independent. Optional connection to AGnd via IC64-16 internal 0 ohm resistor R4.

Shield 1 is the integral plane cable screen (pin 4 on Lemo connectors). Optional connection to the IC128-25 body via internal 0 ohm resistor R7. Optional connection to the HV connector screens via internal 0 ohm resistor R6.

Shield 2 is a special ground associated with the I128 readout electronics. May be ignored for other readout electronics. Optional connection to shield 1 via IC128-25 internal 0 ohm resistors R3, R4.

DGnd is the reference ground for the environmental sensors control and readout.

CAUTION

Do not expose the device to ionizing radiation beams unless all connections to readout electronics and bias supplies are made, or otherwise grounded. Charge build-up and subsequent arcing damage can occur.



Calibration

Gain curves

Approximate gain curves at standard temperature and pressure for protons, 5 mm and 7 mm gaps. Note that the IP section has two 5 mm gaps, so actual gain is twice that shown.

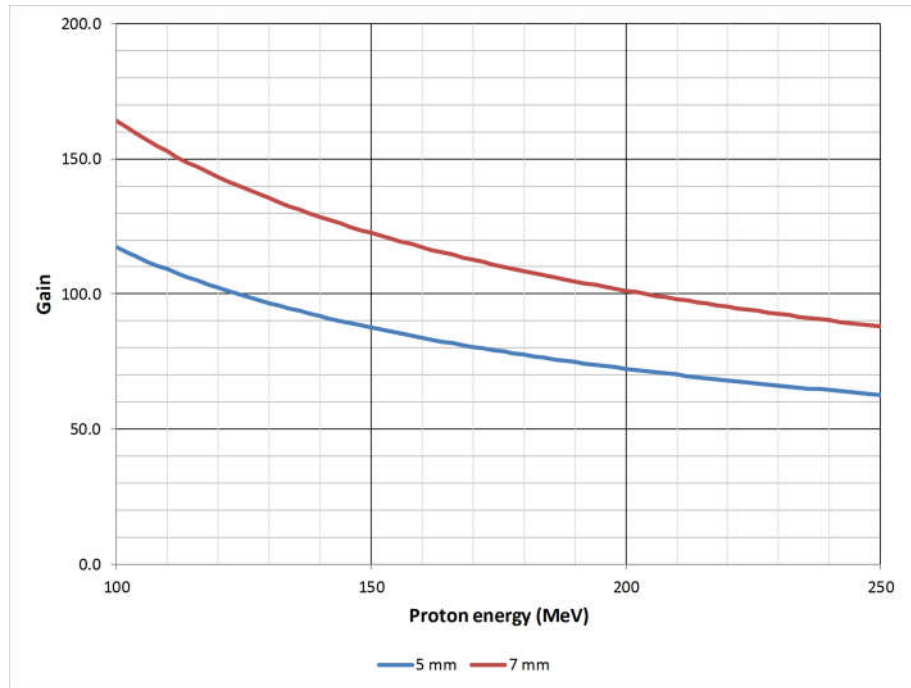
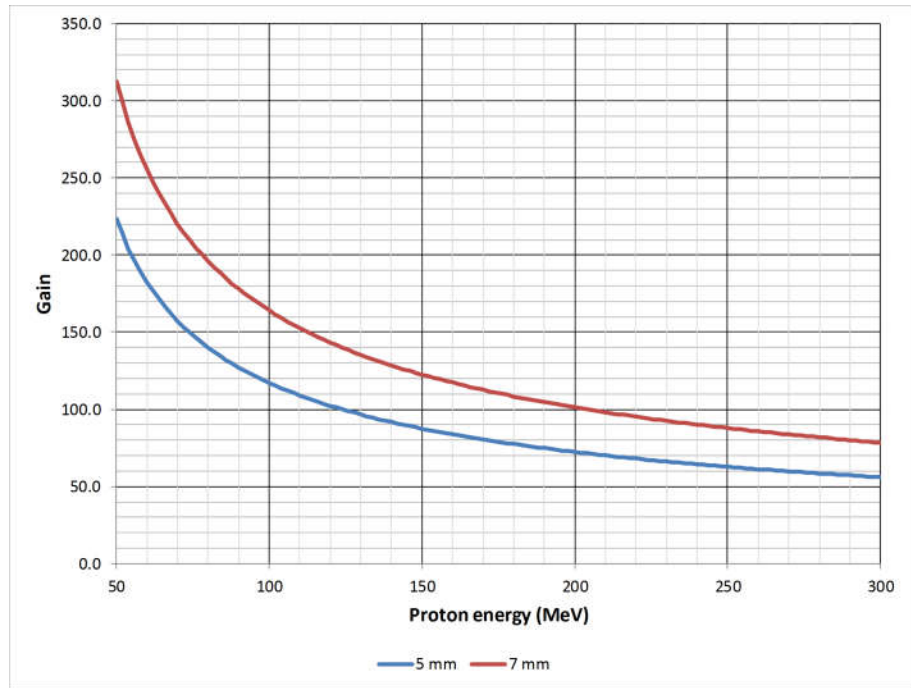

Note: Critical dosimetry measurements must use accurate gain values referred to traceable standards, and regularly validated.



Calibration (cont)																
Readout MUX	<p>Digital bit pattern (TTL levels) to select analog sensor voltage that is switched to pins 6, 2 of monitor connector.</p> <table border="1"> <thead> <tr> <th><i>Bit 1</i></th> <th><i>Bit 0</i></th> <th><i>Selected sensor</i></th> </tr> </thead> <tbody> <tr> <td>0</td> <td>0</td> <td>Temperature (V_{measT})</td> </tr> <tr> <td>0</td> <td>1</td> <td>Pressure (V_{measP})</td> </tr> <tr> <td>1</td> <td>0</td> <td>Relative humidity (V_{measH})</td> </tr> <tr> <td>1</td> <td>1</td> <td>Reference voltage (V_{ref})</td> </tr> </tbody> </table>	<i>Bit 1</i>	<i>Bit 0</i>	<i>Selected sensor</i>	0	0	Temperature (V_{measT})	0	1	Pressure (V_{measP})	1	0	Relative humidity (V_{measH})	1	1	Reference voltage (V_{ref})
<i>Bit 1</i>	<i>Bit 0</i>	<i>Selected sensor</i>														
0	0	Temperature (V_{measT})														
0	1	Pressure (V_{measP})														
1	0	Relative humidity (V_{measH})														
1	1	Reference voltage (V_{ref})														
Temperature	<p>Temperature(centigrade) = $100 * V_{measT}$ Temperature(Kelvin) = Temperature(centigrade) + 273.2</p>															
Pressure	<p>Pressure(psi) = $18.75 * (V_{measP} / V_{ref} - 0.1)$ Pressure(mbar) = Pressure(psi) * 68.95 Pressure(Pa) = Pressure(psi) * 6895</p>															
Humidity	<p>Relative humidity (%) = $157 * (V_{measH} / V_{ref}) - 23.8$</p>															
Gain correction	<p>Nominal gain at standard ambient temperature and pressure (Temperature_{SATP} = 298.15 K, Pressure_{SATP} = 100000 Pa), must be corrected for measured temperature and pressure:</p> <p>Gain = $1 / [Gain_{SATP} * (Pressure_{SATP} / Pressure(Pa)) * (Temperature(Kelvin) / Temperature_{SATP})]$</p> <p>For nominal gains established at other reference temperature and pressure, substitute the appropriate reference values in the equation.</p>															
Factory test																
Environment sensing	Temperature, pressure and humidity sensor function (both channels)															
Humidity	Internal humidity drops to less than 5% in less than 60 minutes															
Connection integrity	All channels respond equally to bias voltage charging transient within tolerance															
HV hold	Every chamber tested for high voltage stability at 2 kV															
HV sensing	Bias voltage loopback matches bias voltage delivered															
Gain flatness	Every chamber tested for gain flatness over full area for all sections better than 5% max peak to peak variation (< 2% rms) on automated X-ray test rig.															
Position	Every chamber tested for position readout accuracy on both axes to better than 250 μm relative to sensor center on automated X-ray test rig.															



Layout

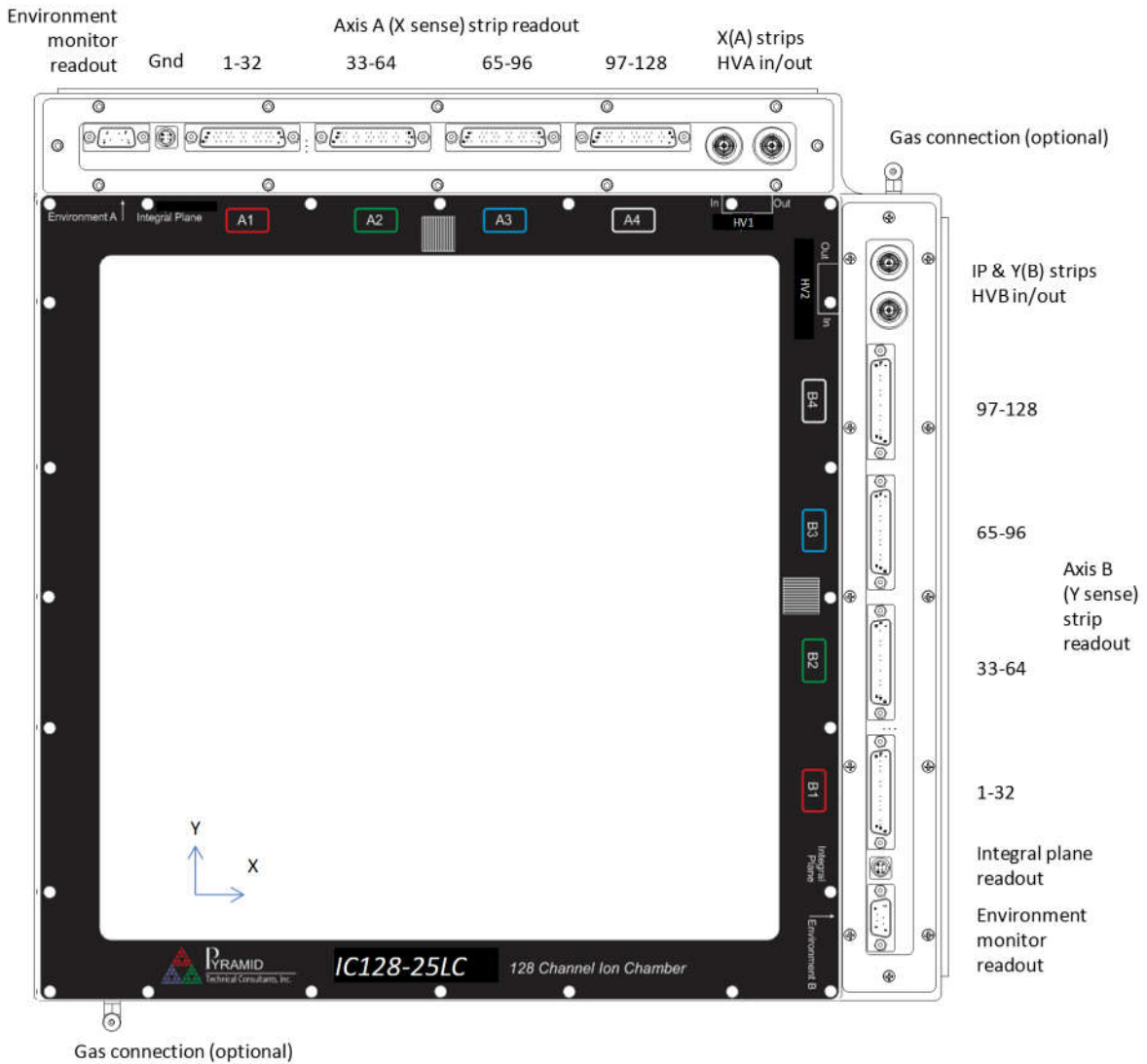

Designation of axes as X / Y, or horizontal / vertical is arbitrary, as it depends upon the orientation of the IC with respect to the beamline.

Strips are numbered sequentially from the lower right corner in the view shown, both axes.

A beam entering through this face passes through the integral gaps first, then the Y(B) strip gap, then the X(A) strip gap.



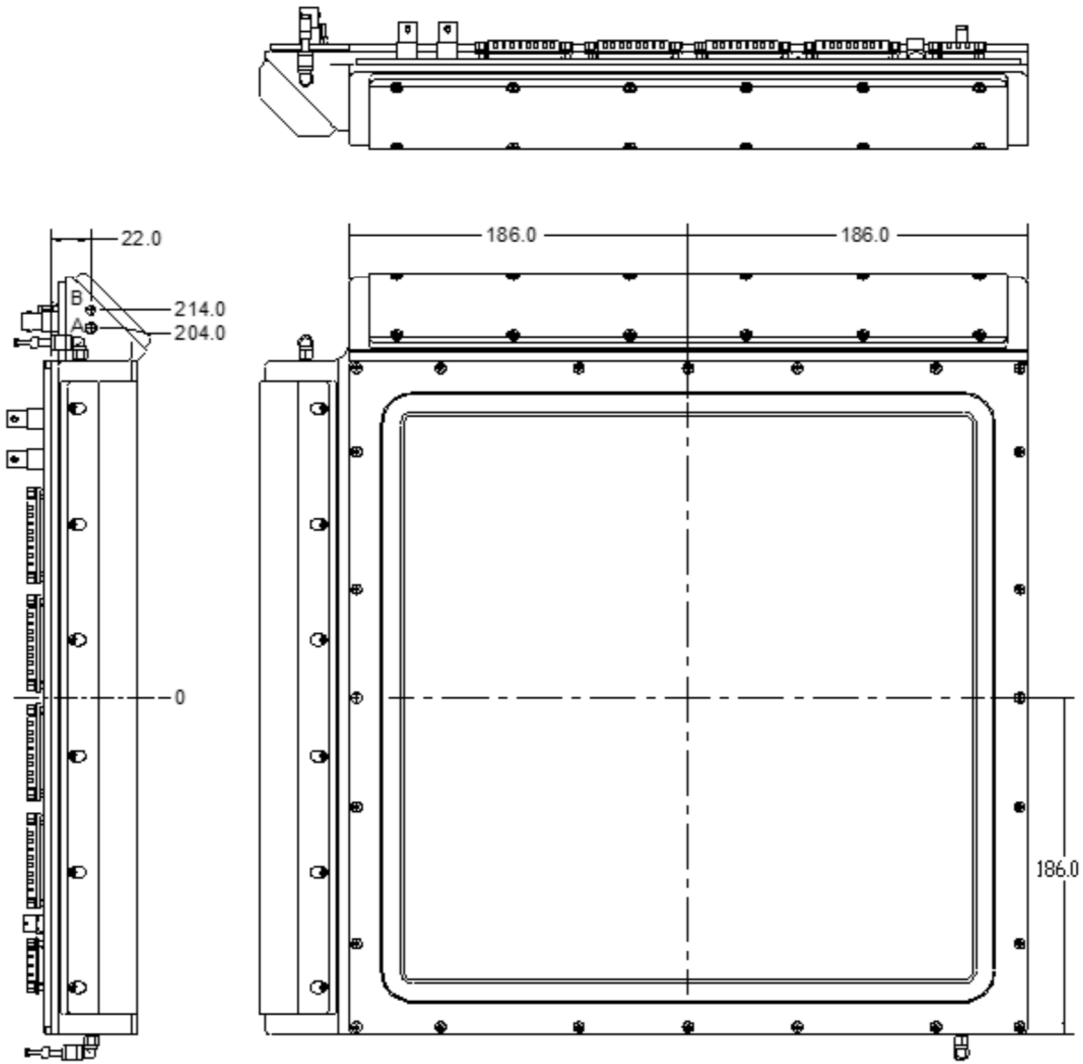

Dims mm



Mounting and fiducial features

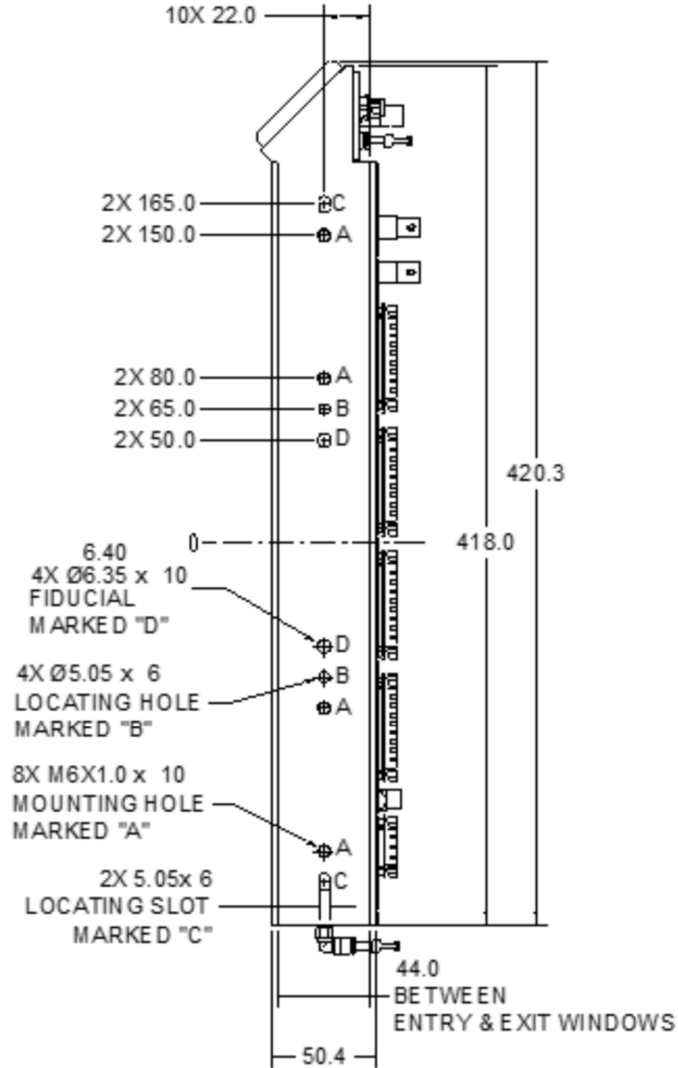

Dims mm

Ordering information

IC128-25LC	Ionization chamber with 25 by 25 cm sensitive area, 128 by 128 strip X and Y position readouts and double gap integral plane dose readout.
-AU	With gold metallization instead of aluminium for readout electrodes.

Pyramid Technical Consultants, Inc.,
 1050 Waltham Street Suite 200
 Lexington MA 02421 USA
 Tel: +1 781 402 1700 (USA),
 +44 1273 492001(UK)

Email: support@ptcusa.com

www.ptcusa.com

The information herein is believed accurate at time of publication, but no specific warranty is given regarding its use. All specifications are subject to change.

All trademarks and names acknowledged.

IC128-25LC_DS_170607

