

Ultra-low WET Quadrant Transmission Ionization Chamber

Features

- 6.0 cm diameter sensitive area
- Ionization chamber with quadrant readout electrodes for beam centering or flatness determination and total flux measurement
- Suited to low-energy beams where minimum material thickness is essential
- Water equivalent thickness 66 μm
- Ultra-thin Kapton^(TM) gold plated electrode foils for minimum scattering, reliable electrical contacts and radiation hardness
- Electrode patterns laser-cut for high geometric precision
- Compatible with I404, F460 and FX4 readout electronics



Applications

- Low energy particle beams in air
- Proton therapy eye lines
- Proton therapy beam flux monitoring
- Proton therapy beam trajectory or flatness monitoring
- General ion beam diagnostics

Specifications

Beam compatibility

Species	Protons, deuterons, alpha, fully-stripped carbon
Energy range	5 MeV/nucleon to > 500 MeV / nucleon
Beam current density range	Up to 100 nA cm ⁻² (particle current) recommended; higher current densities can be measured but will suffer increasing recombination losses. Increased bias voltage reduces recombination.

Sensor

Type	Parallel plate dual ionization chamber with single gap and quadrant readout
High voltage	500-1000 V typical (1560 to 3125 V cm ⁻¹); maximum 1500 V
Sensitive area	60 mm (2.36 inch) diameter
Sensitive volume	Active volume: quadrant electrode to HV electrode. 3.6 mm spacing.
Quadrant geometry	Four equal quadrants (150 μm inter-quadrant gaps typical)



Datasheet

QIC-6E

Sensor (continued)

Gain uniformity	Better than +/-2% for beams within the sensitive area.
Position resolution	Depends on signal to noise ratio and beam profile; 10's of μm achievable in both axes provided beam delivers signal to all quadrants.
Fiducials	Electrode strips tolerance build-up relative to fiducial features on body +/- 0.3 mm nominal, < +/- 0.1 mm typical .

Chamber gas

Operating gas	Dry atmospheric air
Desiccant	One sorb sachet. Sachet can be changed with chamber in situ provided the cover is accessible.

Mechanical

Insertion length	31.4 mm housing face to face.
Overall size	210 mm by 180 mm by 32 mm approx (see figures)
Weight	1.3 kg (2.9 lb) excluding any added mounting brackets.
Operating environment	Clean and dust-free, 0 to 35 C (15 to 25 C recommended , < 70% humidity, non-condensing, minimum vibration (< 0.1g all axes 1 to 50 Hz) Temperature and pressure compensation of chamber gain must be performed.
Shipping and storage environment	-10 to 50 C, < 80% humidity, non-condensing, vibration < 1g all axes, 1 to 20 Hz

Connectors

Quadrant readout	Four Lemo NIM/CAMAC coaxial receptacle (EPA.00.250.DTN). 
------------------	--

HV in / out	Two SHV
-------------	---------

Environmental sensors	Micro-D 9-pin plug (Molex 836119023)  <table border="1"><tr><td>1</td><td>n/c</td><td>6</td><td>I2C SCL clock in</td></tr><tr><td>2</td><td>n/c</td><td>7</td><td>I2C SDA data bidirectional</td></tr><tr><td>3</td><td>n/c</td><td>8</td><td>3.3 VDC in</td></tr><tr><td>4</td><td>n/c</td><td>9</td><td>Gnd rtn for 5.0, 3.3 V</td></tr><tr><td>5</td><td>5.0 VDC in</td><td></td><td></td></tr></table>	1	n/c	6	I2C SCL clock in	2	n/c	7	I2C SDA data bidirectional	3	n/c	8	3.3 VDC in	4	n/c	9	Gnd rtn for 5.0, 3.3 V	5	5.0 VDC in		
1	n/c	6	I2C SCL clock in																		
2	n/c	7	I2C SDA data bidirectional																		
3	n/c	8	3.3 VDC in																		
4	n/c	9	Gnd rtn for 5.0, 3.3 V																		
5	5.0 VDC in																				



Beam scattering

Layers in beam path

1	7.5 μm	Polyimide foil aluminized both sides 0.1 μm (window)
2	14.0 mm	Fill gas (non-active gap)
3	7.5 μm	Polyimide foil aluminized both sides 0.1 μm (HV electrode)
4	3.6 mm	Fill gas (active gap)
5	7.5 μm	Polyimide foil gold coated active gap side 40 nm (quadrant electrode)
6	8.4 mm	Fill gas (non-active gap)
7	7.5 μm	Polyimide foil aluminized both sides 0.1 μm (window)

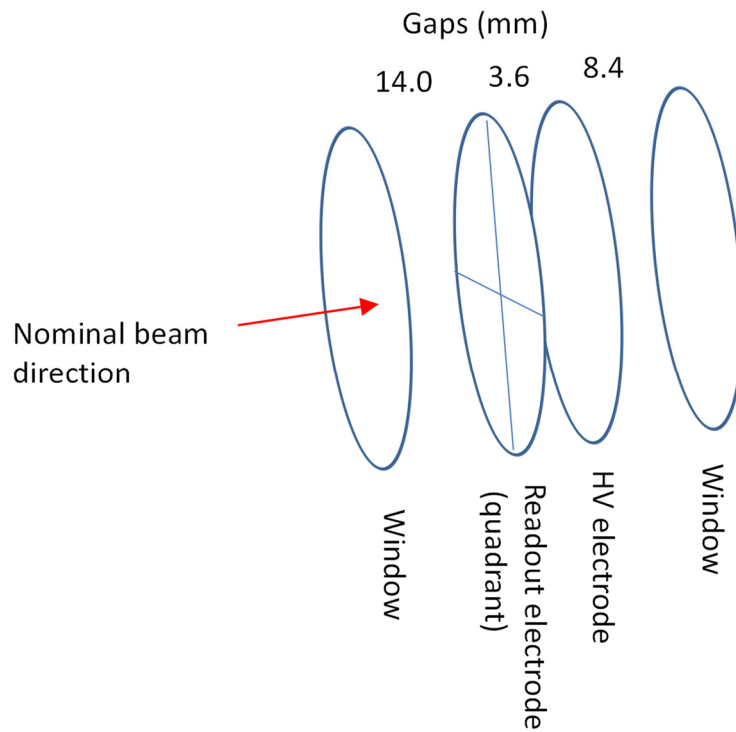

Sequence is for nominal beam direction, entering on decal face. Beam can enter instead on the other face without affecting performance.
 Total effective thickness 66 μm water equivalent.

CAUTION



Do not expose the device to ionizing radiation beams unless all connections to readout electronics and bias supplies are made, or otherwise grounded. Charge build-up and subsequent arcing damage can occur.



Calibration

Gain curve

Approximate gain curve for air at standard ambient temperature and pressure for protons calculated by Geant4.

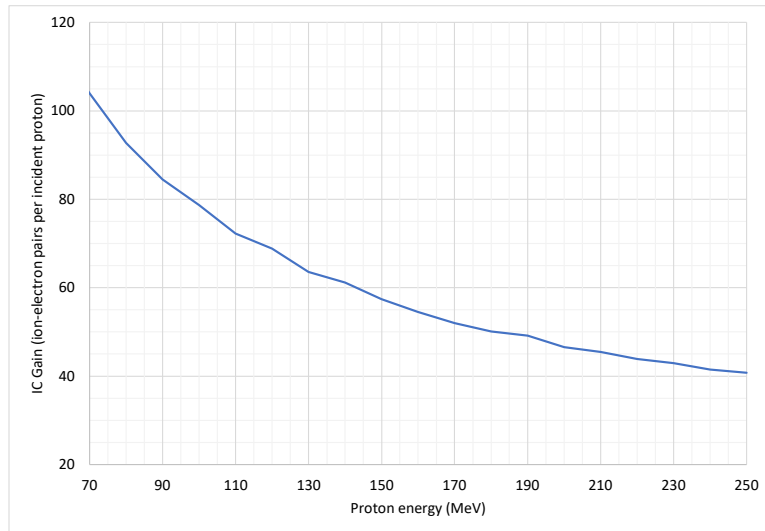
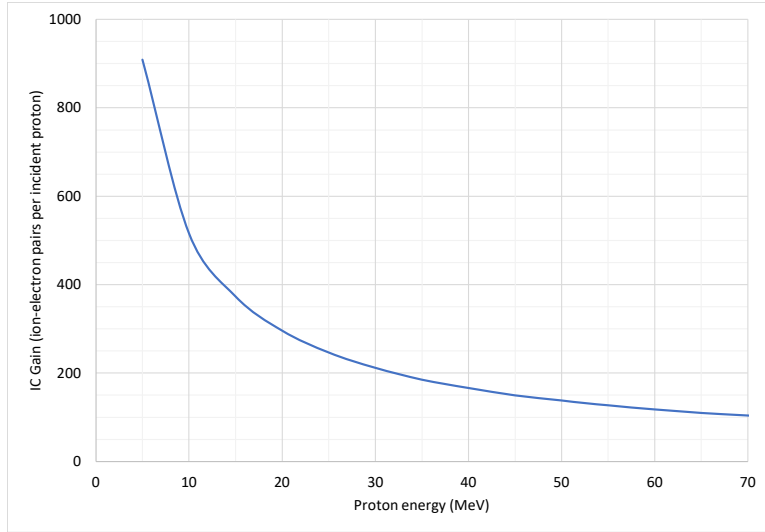

Note: Critical dosimetry measurements must use accurate gain values referenced to traceable standards, and regularly validated.

Gain correction

Nominal gain at standard ambient temperature and pressure (Temperature_{SATP} = 298.15 K, Pressure_{SATP} = 100000 Pa), must be corrected for measured temperature and pressure:

$$\text{Gain} = \text{Gain}_{\text{SATP}} / [(\text{Pressure}_{\text{SATP}} / \text{Pressure}(\text{Pa})) * (\text{Temperature}(\text{Kelvin}) / \text{Temperature}_{\text{SATP}})]$$

For nominal gains established at other reference temperature and pressure, substitute the appropriate reference values in the equation.



Position response or beam flatness

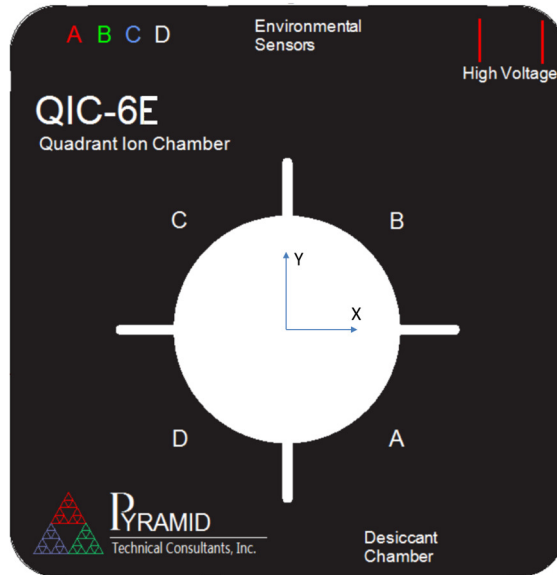

The decal is applied to the nominal beam entrance face. The QIC-6E has no actual preferred beam entrance side (the beam can enter in either direction) so the direction is arbitrary to suit a particular installation. Designation of the sensing axis as X / Y, or horizontal / vertical is also arbitrary, as it depends upon the orientation of the IC with respect to the beamline, and of the beamline relative to any other reference coordinate system.

Four channel electronics often include built-in real-time position functions such as difference over sum. The functions below give the axis directions shown above.

$$X = ((A+B)-(C+D))/(A+B+C+D) \quad Y = ((B+C)-(A+D))/(A+B+C+D)$$

The plot on the left below shows the position function curve for a 2 mm sigma beam crossing the sensor. The log ratio position function shown in the right hand plot below may be preferred for some applications:

$$X = \log((A+B)/(C+D)) \quad Y = \log((B+C)/(A+D))$$

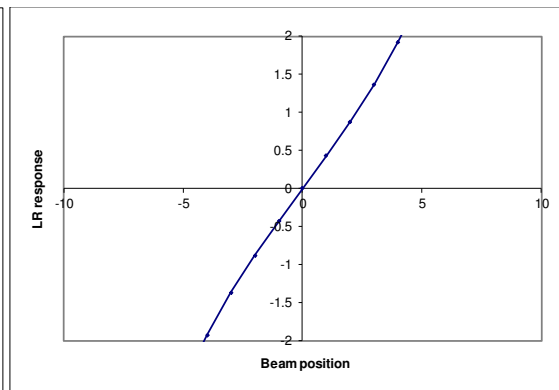
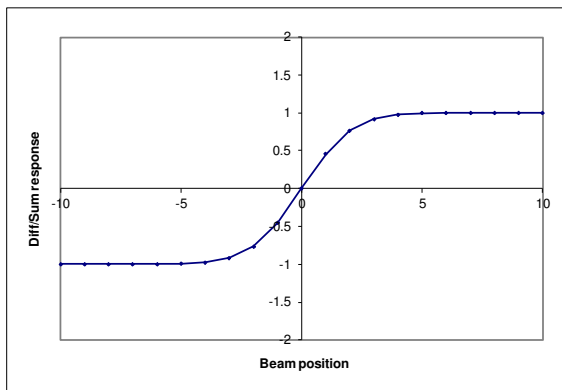

Similar position functions can also be used for broad beams such as passively scattered proton therapy beams, in which case they indicate beam flatness rather than centroid location.



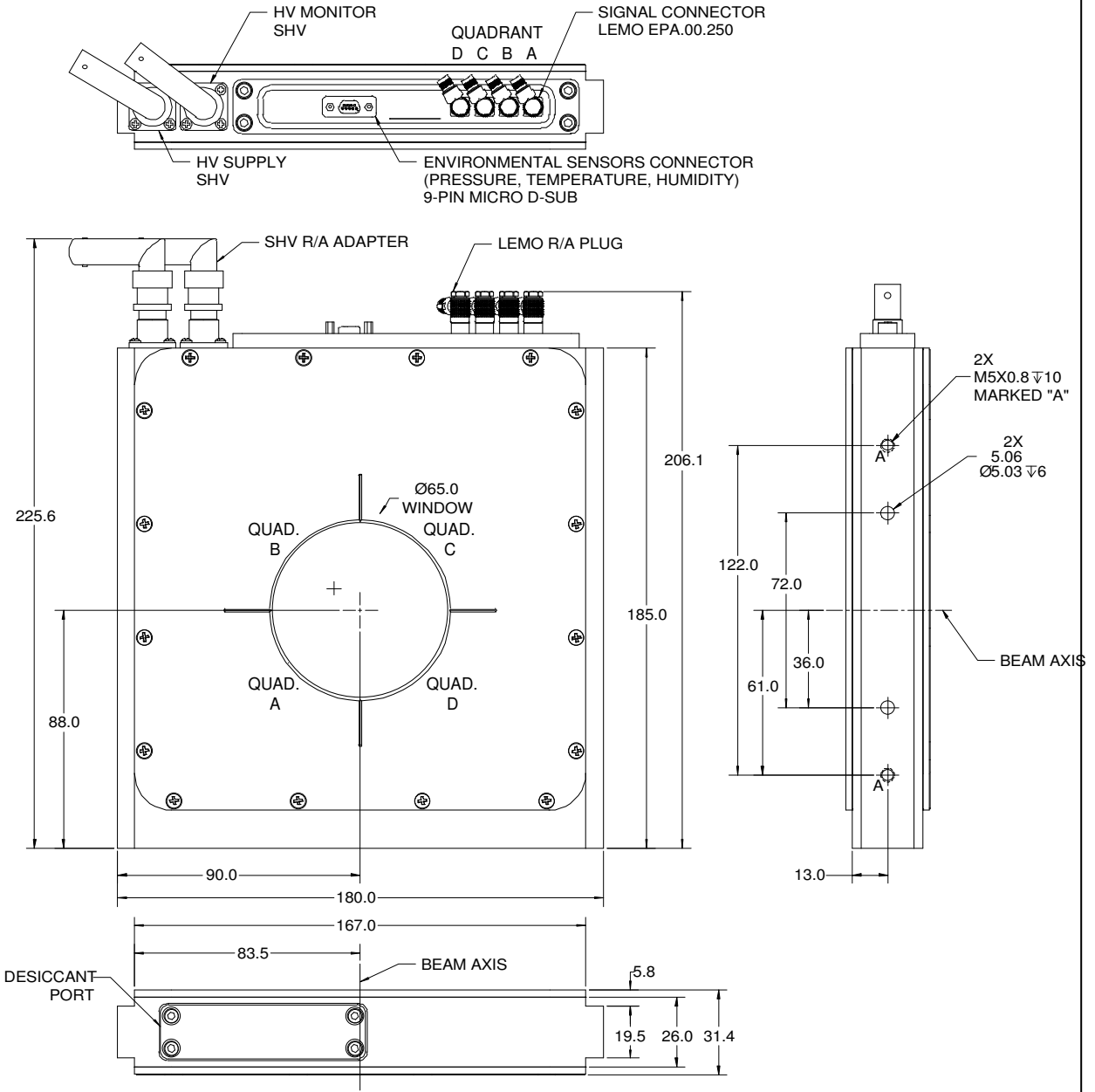

Dims mm
Third angle

Nominal beam exit face shown.

Right angle SHV through adaptors (Paternack PE9338) and right angle Lemo 00 coaxial connectors (Lemo FLC.00) can be used to as needed to aid cable routing.



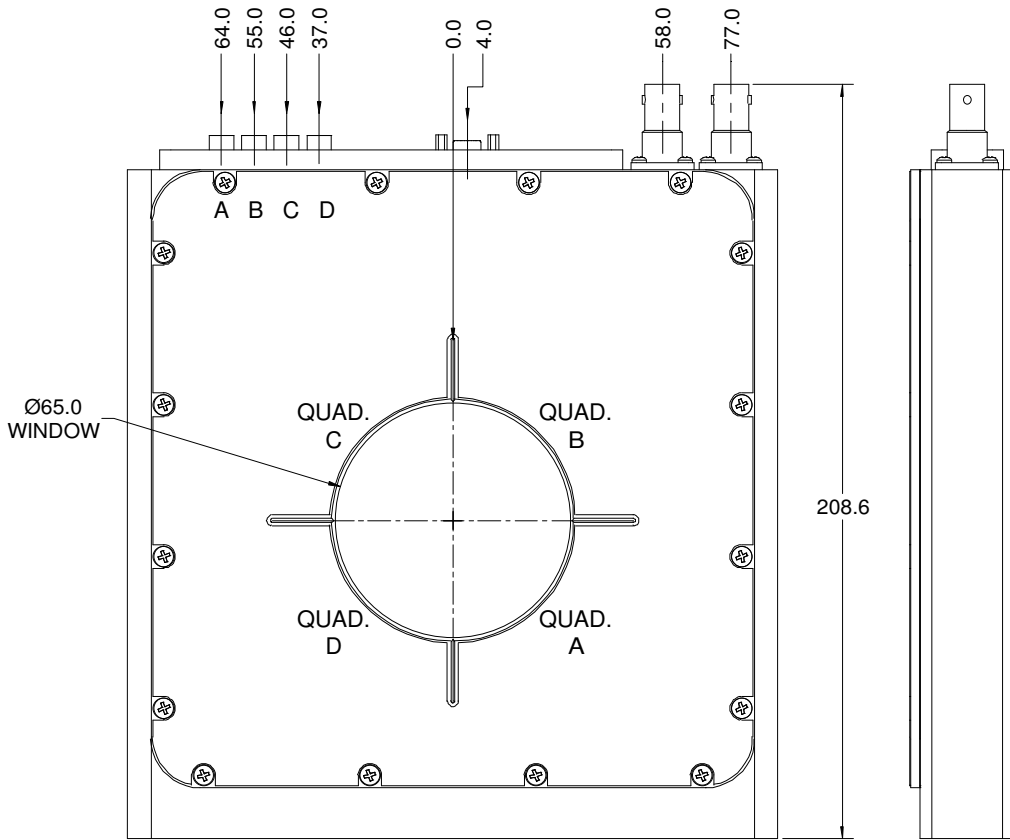

Nominal beam entrance face (decal applied to this face)

Dims mm
Third angle

Ordering information

QIC-6E	Thin film ionization chamber with 60 mm diameter sensitive area, quadrant readout electrode.
SK-DES2-QIC6E	Sealed pack of two desiccant sacs.
ADAP-SHV-RA	SHV through connector, right angle.

Pyramid Technical Consultants, Inc.,
135 Beaver Street Suite 102
Lexington MA 02452 USA
Tel: +1 781 402 1700 (USA),
+44 1273 492002 (UK)
+84 935 051 905 (VN)

The information herein is believed accurate at time of publication, but no specific warranty is given regarding its use. All specifications are subject to change.

All trademarks and names acknowledged.

QIC-6E_DS_240822

