

N2400

Pneumatic Actuator Controller

User Manual

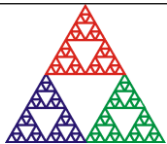

Pyramid Technical Consultants, Inc.

135 Beaver Street Suite 102, Waltham, MA 02452 USA

US: TEL: (781) 402 1700 ♦ FAX: (781) 402-1750 ♦ EMAIL: SUPPORT@PTCUSA.COM

Europe: TEL: +44 1273 493590

1 Contents

1	Contents.....	2
1.1	<i>Table of figures.....</i>	5
2	Safety Information.....	6
3	Models	8
4	Scope of Supply.....	9
5	Optional Items	10
5.1	<i>Power supplies.....</i>	10
5.2	<i>Data cables.....</i>	10
5.3	<i>Fiber-optic loop.....</i>	10
6	Intended Use and Key Features	11
6.1	<i>Intended Use.....</i>	11
6.2	<i>Key Features.....</i>	11
7	Specification	12
8	Installation.....	18
8.1	<i>Mounting.....</i>	18
8.2	<i>Grounding and power supply.....</i>	18
8.3	<i>Connection to equipment.....</i>	18
9	Getting Started	20
9.1.1	<i>Powering up.....</i>	20
9.1.2	<i>Manual control from the front panel.....</i>	20
9.1.3	<i>Remote control in ASCII mode</i>	21
10	Using the PSI DiagnosticG1 Host Program	24
10.1	<i>Installing the PSI Diagnostic Program.....</i>	24

10.2	<i>Establishing communication with the N2400</i>	24
10.3	<i>Data tab</i>	25
10.4	<i>Setup tab</i>	27
10.5	<i>Device tab</i>	27
11	Other Host Computer Software	29
12	Connectors	32
12.1	<i>Rear panel connectors</i>	32
12.1.1	Actuator control and readback.....	32
12.1.2	Power input.....	32
12.1.3	Fiber-optic communications.....	32
12.1.4	USB communications.....	32
12.1.5	RS-232 communications.....	33
12.2	<i>Alternative actuator connections (N2400-D25 model)</i>	33
12.2.1	Actuator control.....	33
12.2.2	Limit switch readback.....	33
13	Controls and Indicators	35
13.1	<i>Front panel controls and indicators</i>	35
13.1.1	In/Out switch.....	35
13.1.2	Auto/Man switch.....	35
13.1.3	Auto indicator.....	35
13.1.4	Man indicator.....	36
13.1.5	In indicator.....	36
13.1.6	Out indicator.....	36
13.2	<i>Rear panel controls</i>	36
13.2.1	Mode switch.....	36
13.2.2	Address switch.....	36
13.3	<i>Rear panel indicators</i>	36
13.3.1	Power.....	36
13.3.2	Xmit.....	37
13.3.3	Rev.....	37
13.3.4	Status.....	37
13.3.5	Link.....	37

14	Software updates	38
15	Safety Interlocks	41
15.1	<i>Safety relay interlock circuit.....</i>	<i>41</i>
15.2	<i>Lock out / Tag out.....</i>	<i>42</i>
16	ASCII Communication.....	43
16.1	<i>ASCII Protocol – SCPI.....</i>	<i>43</i>
16.1.1	<i>Messages</i>	<i>43</i>
16.1.2	<i>Status registers</i>	<i>44</i>
16.1.3	<i>Host Commands</i>	<i>44</i>
16.2	<i>ASCII Protocol – Terminal Mode.....</i>	<i>48</i>
17	Fault-finding	49
18	Maintenance	51
19	Support.....	52
20	Returns procedure.....	53
21	Disposal.....	54
22	Declaration of Conformity.....	55
23	Revision History.....	56

1.1 Table of figures

Figure 1. N2400 chassis rear and front panels. Dimensions mm.	14
Figure 2. N2400 chassis top and side views. Dimensions mm.	15
Figure 3. N2400-D25 chassis rear panel.	16
Figure 4. N2400 chassis front panel (early models). Dimensions mm.	17
Figure 5. Schematic N2400 installation for remote interfacing of pneumatic actuators	19
Figure 6. Actuator test lead. View on N2400 connector / solder side of mating connector	20
Figure 7. RS232 connection cable from the N24000 to a PC serial port (DB9).	21
Figure 8. Hyperterminal COM port setup.	22
Figure 9. Hyperterminal terminal settings	22
Figure 10. Example Hyperterminal session (terminal mode)	23
Figure 11. PSI Diagnostic Search Utility – adding a target IP address and port	25
Figure 12. PSI Diagnostic Search Utility – detection in progress	25
Figure 13. Data tab: A N2400 is connected via an A500 controller, on loop 2 at address 4.	26
Figure 14. Data tab: various states for channels 1-3.	27
Figure 15. Device tab, showing firmware update utility controls.	28
Figure 16. N2400 block schematic.	30
Figure 17. Actuator channel control and indicator cluster	35
Figure 18. Selecting the hex file to load.	39
Figure 19. Firmware upload in progress.	40
Figure 20. Example safety circuit	41

2 Safety Information

This unit is designed for compliance with harmonized electrical safety standard EN61010-1:2000. It must be used in accordance with its specifications and operating instructions. Operators of the unit are expected to be qualified personnel who are aware of electrical safety issues. The customer's Responsible Body, as defined in the standard, must ensure that operators are provided with the appropriate equipment and training.

The unit is designed to make measurements in **Measurement Category I** as defined in the standard.



The N2400 does not generate dangerous voltages, nor is it designed to measure directly such voltages. However it is intended to control pneumatic actuator systems which may present pinch hazards. Appropriate precautions must be taken when working on the actuator assemblies. The lock out / tag out protocol is recommended. The service engineer should disconnect the cable from the N2400 to the actuator, and lock and tag a cover over the cable end. The engineer should retain the key until the work is completed.



If an actuator is performing a safety-critical function, then a safety-rated hardware interlock system should be placed in between the N2400 and the actuator.

The unit must not be operated unless correctly assembled in its case. Only Service Personnel, as defined in EN61010-1, should attempt to work on the disassembled unit, and then only under specific instruction from Pyramid Technical Consultants, Inc. or their authorized distributors.

The unit is designed to operate from +24VDC power, with a maximum current requirement of 1250mA. A suitably rated power supply module is available as an option.

The unit must be grounded by secure connection to a grounded conducting surface. If the unit is mounted on an insulating surface, then one of the four mounting screws must be re-assigned as a grounding connection.

Some of the following symbols may be displayed on the unit, and have the indicated meanings.



Direct current



Earth (ground) terminal



Protective conductor terminal



Frame or chassis terminal



Equipotentiality



Supply ON



Supply OFF



CAUTION – RISK OF ELECTRIC SHOCK



CAUTION – RISK OF DANGER – REFER TO MANUAL

3 Models

N2400	24-channel pneumatic actuator controller.
N2400-D25	N2400 with optional DSub 25-pin alternative rear panel connectors

4 Scope of Supply

N2400 model as specified in your order.

PSU24-40-1 power supply

ADAP-D9F-MINIDIN Adaptor cable for RS-232 port

USB memory stick containing:

- User manual

- PSI diagnostic software files

- USB drivers and utilities

- Test results

Optional items as specified in your order.

Note: OEM customers may not receive all items.

5 Optional Items

5.1 Power supplies

PSU24-40-1. +24 VDC 40 W PSU (100-250 VAC, 50-60 Hz, IEC C14 3-pin plug receptacle) with output lead terminated in 2.1mm threaded jack.

5.2 Data cables

CAB-ST-HCS-10-ST Fiber-optic cable, 200 um silica, ST terminated, 10'.

A pair of fibers is required to make up a point to point connection.

5.3 Fiber-optic loop

A360 two-port fiber-optic loop controller / Ethernet adaptor.

A500 intelligent real-time controller with Ethernet interface.

A560 intelligent real-time controller with 10 fiber-optic loop ports and Ethernet interface.

6 Intended Use and Key Features

6.1 Intended Use

The N2400 is intended for 24 VDC solenoid valve control and limit switch readback from pneumatic actuator motion systems. Up to 24 independent channels can be controlled, each with a single control output and two limit switch readbacks. Control and monitoring will generally be handled by a host computer system communicating with the N2400 via one of its data interfaces. However, any channel can also be put into manual control by a front panel switch, and the actuator position is then determined by the corresponding front panel position switch. The host computer, if connected, is still able to read back the limit switch state when manual control is asserted.

The N2400 can control directly any actuator systems which are controlled by 24 VDC levels with maximum current requirement in the on condition of 75 mA. A typical example is the SMC SY300 series, which has a DC solenoid rating of 0.45 W maximum. More complex actuators, for example three position systems which are driven by two cylinders each with its own solenoid valve, can also be controlled but now the host software system must implement the necessary state machine, and handle any constraints.

The N2400 has design features which make it tolerant of electrically noisy environments, but the place of use is otherwise assumed to be clean and sheltered, for example a laboratory or light industrial environment. The unit may be used stand-alone, or networked with other devices and integrated into a larger system. Users are assumed to be experienced in the general use of precision electronic circuits for sensitive measurements, and to be aware of the dangers that can arise in high-voltage circuits.

6.2 Key Features

24 independent channels.

Individual manual control can be selected for each channel.

48 opto-isolated limit switch inputs, two per channel.

Can be operated in a fiber-optic serial communication loop with up to fifteen other devices.

100BaseT Ethernet interfacing to a host computer available through the A360, A500 and A560 loop controllers.

7 Specification

Outputs	
Number	24, independent, one per actuator channel
Voltage	+24 VDC switched
Current	50 mA nominal per channel, 75 mA maximum (all outputs on)
Fuse rating	100 mA resetting thermal fuse on each output
Inputs	
Number	24 pairs, independent, two per actuator channel
Configuration	Opto-coupled, grounding input via remote switch closure indicates limit reached. 24 VDC source voltage provided for each channel, limited by 5 kohm internal source resistor
Controls	
Actuators (front panel)	Auto/manual mode rotary switch, one per channel. Manual control actuator in/out rotary switch, one per channel. Note: early models used toggle switches.
Communications (rear panel)	10 position rotary switch for communication mode selection 16 position rotary switch for loop address selection
Displays	
Actuators (front panel)	Auto/manual indicator LEDs, one pair per channel Actuator in/out indicator LEDs, one pair per channel
Communications and status (rear panel)	Four LEDs (transmit, receive, status, link). Three LEDs (fiber-optic / USB / RS-232)
Communications options	Fiber optic (10 Mbit/sec). Ethernet connection through A360, A500 or A560 loop controllers. USB (3 Mbit/sec) RS-232 (up to 115 kbit/sec)
Power input	+24 VDC (+/-2 V), 200 mA standby (no actuators driven), 50 mA additional typical per driven solenoid. Input fuse rating 2.5 A.

Case	Stainless steel sheet, aluminium alloy front panel.
Case protection rating	The case is designed to rating IP43 (protected against solid objects greater than 1mm in size, protected against spraying water).
Weight	3.6 kg (8.0 lb).
Operating environment	0 to 35 C (15 to 25 C recommended) < 80% humidity, non-condensing vibration < 0.2 g all axes, 1 to 100Hz
Shipping and storage environment	-10 to 50C < 80% humidity, non-condensing vibration < 2 g all axes, 1 to 100 Hz
Dimensions	2U 19" chassis, 281 mm deep (see figures 1 and 2).

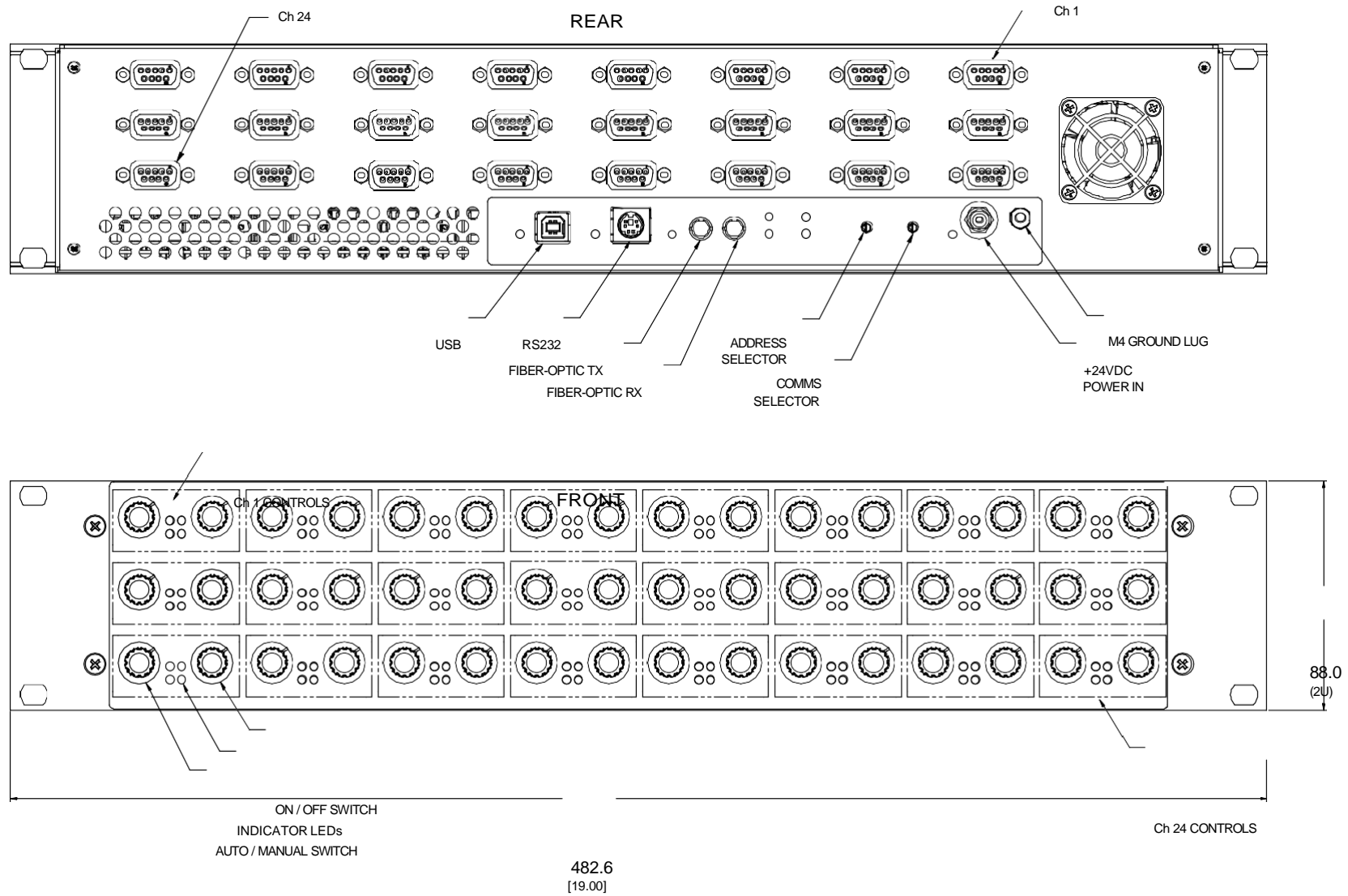

Figure 1. N2400 chassis rear and front panels. Dimensions mm.

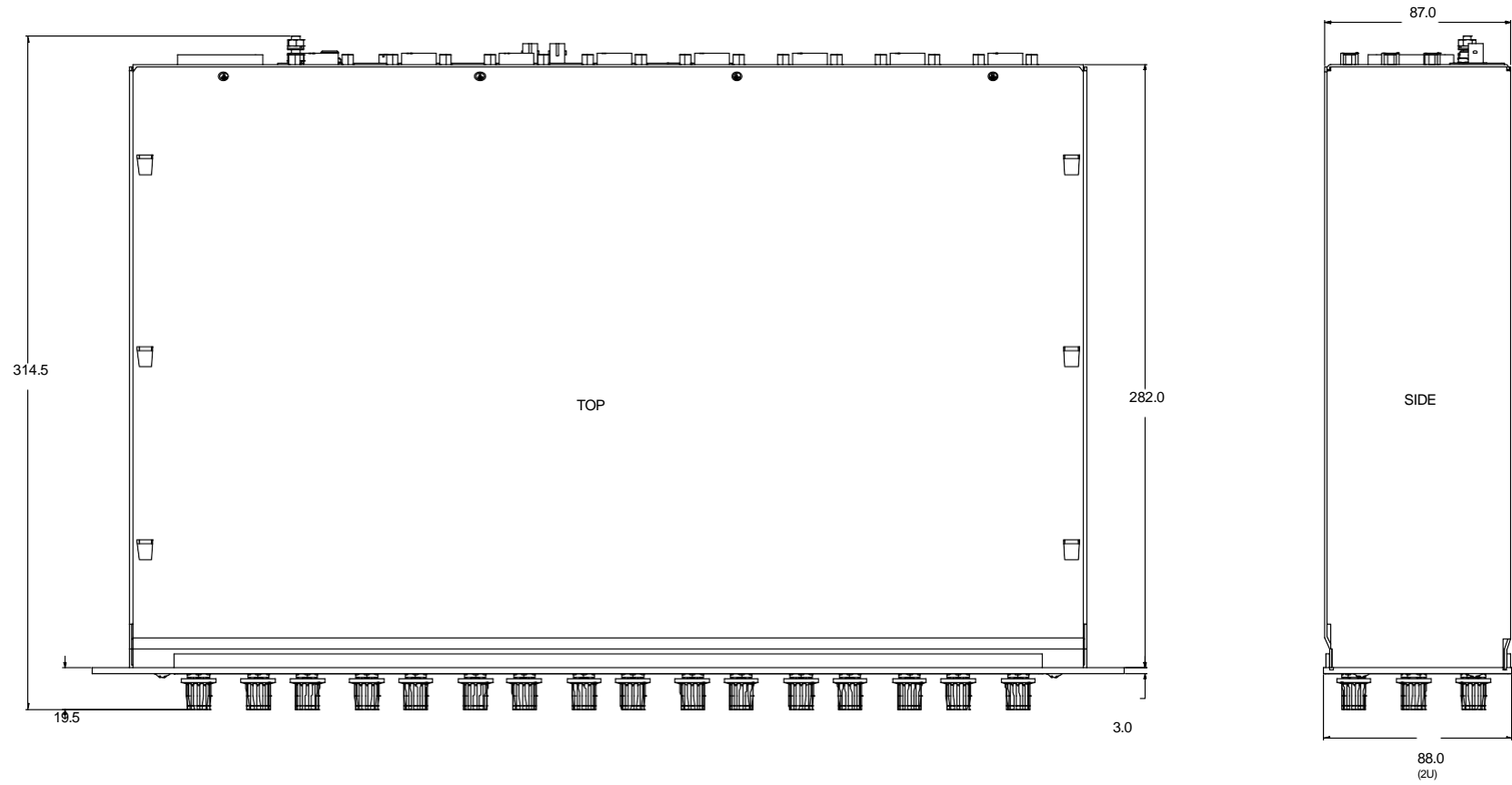

Figure 2. N2400 chassis top and side views. Dimensions mm.

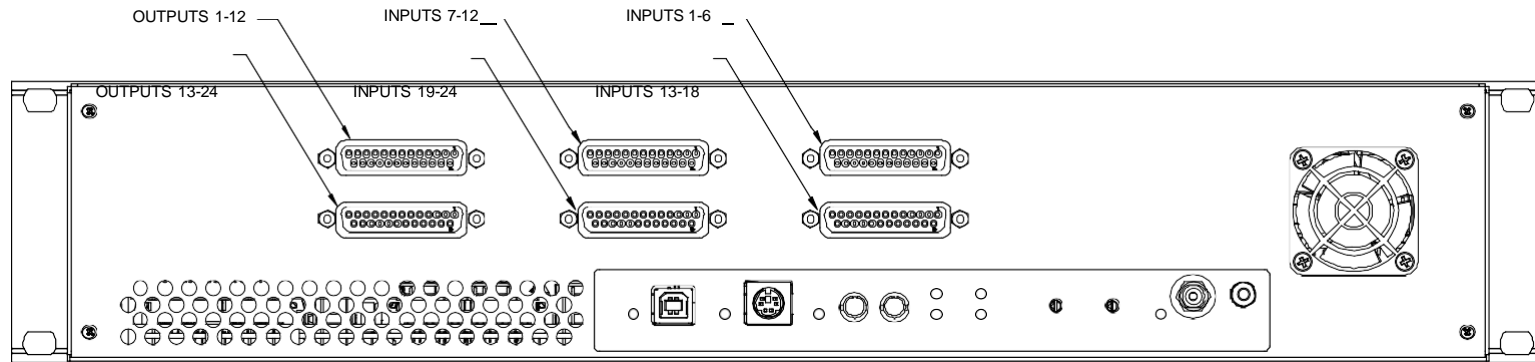

Figure 3. N2400-D25 chassis rear panel (optional alternative arrangement).

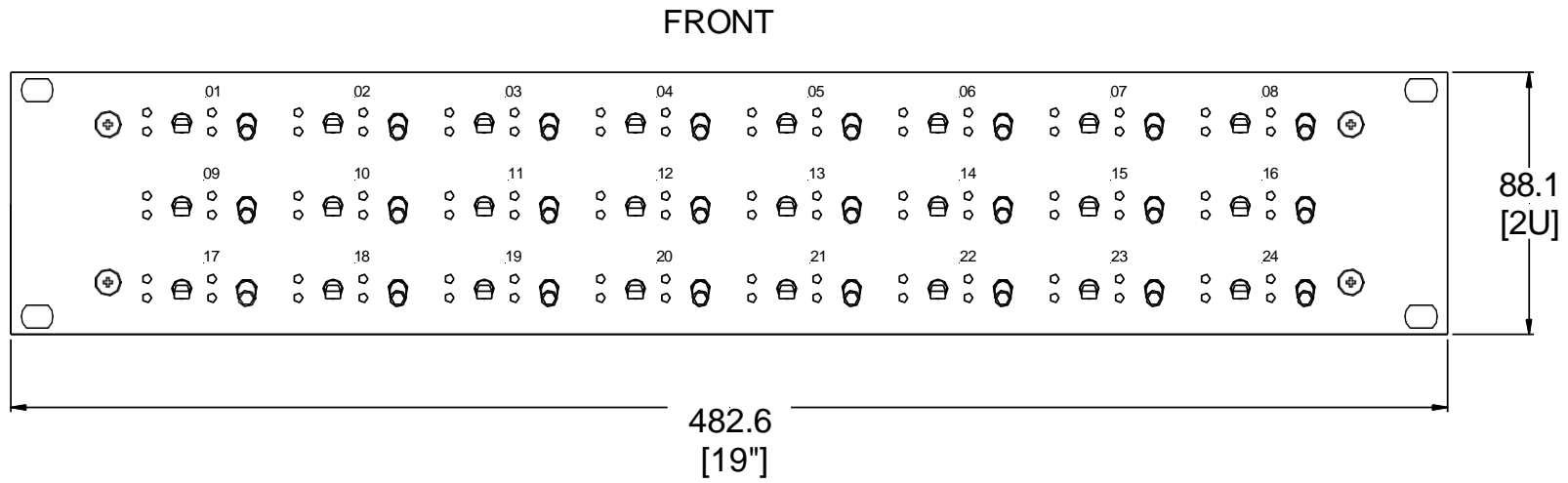

Figure 4. N2400 chassis front panel with toggle switches (early models only). Dimensions mm.

8 Installation

8.1 Mounting

The N2400 should be mounted in a standard 19" rack system. We recommend that you use chassis supports rather than relying on the front panel alone for mounting. The unit may be simply placed on a level surface for initial testing.

The rack depth position should be sufficient to accommodate connectors and cable bend radii. Leave at least 100 mm clearance for the cooling fan to exhaust into. The combined weight of a full complement of cables to actuators is considerable, so adequate support must be provided for the cables to avoid excessive strain on the rear panel.

Best performance will be achieved if the N2400 is in a temperature-controlled environment.

8.2 Grounding and power supply

A secure connection should be made via the ground lug to local ground potential.

+24 VDC power should be provided from a suitably-rated power supply with the following minimum performance:

Output voltage	+24 +/- 0.5 VDC
Output current	2000 mA minimum, 5000 mA maximum
Ripple and noise	< 100 mV pk-pk, 1 Hz to 1 MHz
Line regulation	< 240 mV

The N2400 includes an internal automatically re-setting PTC fuse rated at 2.5 A. The nominal maximum load if 75 mA is being supplied to every actuator output is 2.0A. However the external supply should in no circumstances be rated higher than the N2400 connector limit of 5 A, and a maximum of 3.0 A is recommended.

8.3 Connection to equipment

Figure 5 shows in schematic form a typical installation to control and read a suite of pneumatic actuators. Only one actuator is shown of a possible maximum of twenty-four. The N2400 front panel has a blank area below each switch pair where you can affix system-specific identification of the actuator connected to that channel.

A switched 24 VDC output from the N2400 energizes or de-energizes the solenoid valve on the actuator, which thus directs gas pressure to one or other of its output ports, causing the actuator to drive to the relevant physical limit. Microswitches or similar potential-free contact devices fitted to the actuator assembly close to pull down the N2400 opto-coupler limit switch inputs when the actuator is at end of travel.

The N2400 is shown on a fiber-optic communication loop, under control of one of the Pyramid Technical Consultants, Inc. loop controllers A360, A500, A560 or other product with a fiber-optic loop port). Software on the host computer exposes the I/O provided by the N2400.

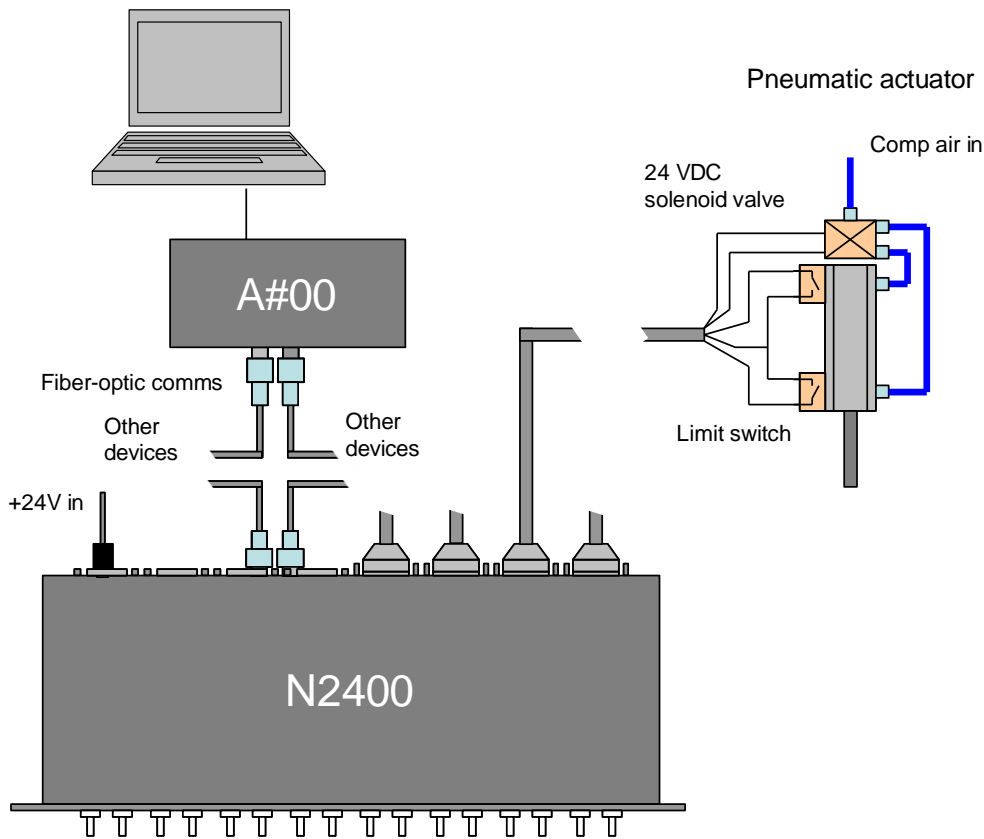

Figure 5. Schematic N2400 installation for remote interfacing of pneumatic actuators

The N2400 may be the only device on the communication loop, or one of up to fifteen devices. As the number of devices is increased, the loop bandwidth has to be shared, so for fast control you would generally keep the number of devices on each loop to the minimum. However the N2400 has low bandwidth requirements, so this is a minor concern if the N2400 and similar devices are the only devices on the loop.

9 Getting Started

9.1.1 Powering up

Before installing the N2400 in its final location, and if it is the first time you have used a N2400, we recommend that you familiarize yourself with its operation on the bench. You can check the unit powers up correctly, establish communications, run the internal calibration procedure, and read the internal calibration current.

Inspect the unit carefully to ensure there is no evidence of shipping damage. If there appears to be damage, or you are in doubt, contact your supplier before proceeding.

Connect 24 V DC power but no other connections. The front panel auto/manual LEDs will illuminate according to the positions of the auto/manual toggle switches. No limit switch indicators should be lit. The rear panel device status LEDs should go through a startup sequence when the power is applied. When the N2400 has started correctly, the status LED on the rear panel will be green, but the link LED will be off. This shows that the N2400 processor is running, but that the N2400 is not yet established on a communication loop nor is handling I/O.

9.1.2 Manual control from the front panel

At this stage you may wish to confirm that an actuator can be driven under manual control. Make up a lead for the actuator as shown in figure 6.

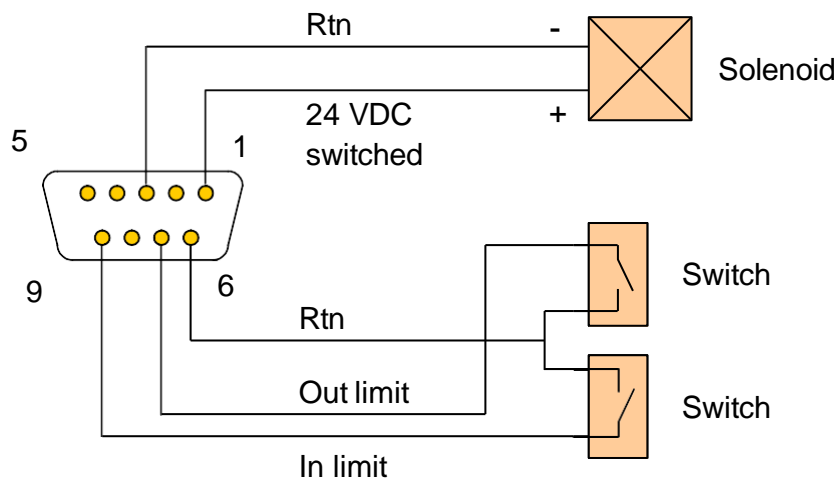

Figure 6. Actuator test lead. View on N2400 connector / solder side of mating connector

CAUTION



If you are bench testing a pneumatic actuator with gas pressure applied, the mechanism will move. Be sure that this is safe, and beware of any trap or pinch hazards.

Turn the switch for the channel you are testing to the manual position. You should see the manual mode indicator LED illuminate. The in/out switch should now energize and de-energize the solenoid. If the solenoid is part of a solenoid valve, you can often hear the valve switching, and there may be an indicator on the valve to confirm the switching. If the gas pressure is on, and the actuator is correctly set up, then it will move. Check the limit switch LEDs illuminate at the ends of travel either by pressing the switches directly or allowing the motion to actuate them.

9.1.3 Remote control in ASCII mode

The simplest way to establish communications from a host computer for the first time is to use the N2400 RS-232 serial port and the ASCII communications protocol. This way you can establish remote control without needing to install any new software on your PC, as a basic terminal program such as Hyperterminal or puTTY is sufficient.

Make a connection to a PC serial port. A three wire lead terminated in a six-pin mini-DIN male connector (PS/2 mouse type) and a nine-pin D female is required. Alternatively you can use a standard 9-way serial cable plus the ADAP-D9F-MINIDIN adaptor. When the connector is pushed home in the N2400, the “optical” LED should extinguish and the “RS232” should illuminate. Connecting to this port forces the N2400 to be a listening device.

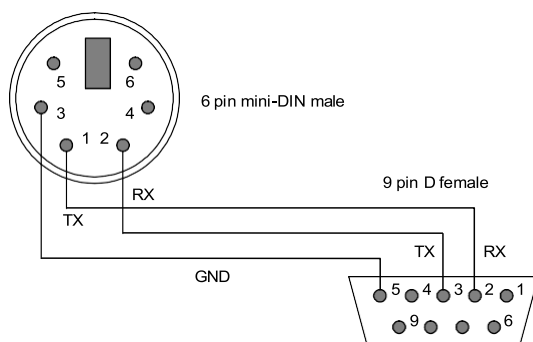

Pins are shown looking at the face of the N2400 connectors / solder side of cable connectors.

Figure 7. RS232 connection cable from the N24000 to a PC serial port (DB9).

Set the address rotary switch to position “4” (address 4; this is an arbitrary example) and the mode rotary switch to position “6” (ASCII communication, 115 kbps).

Configure a terminal session to use COM1 (or other available port on your PC). The following figures illustrate this using Windows Hyperterminal.

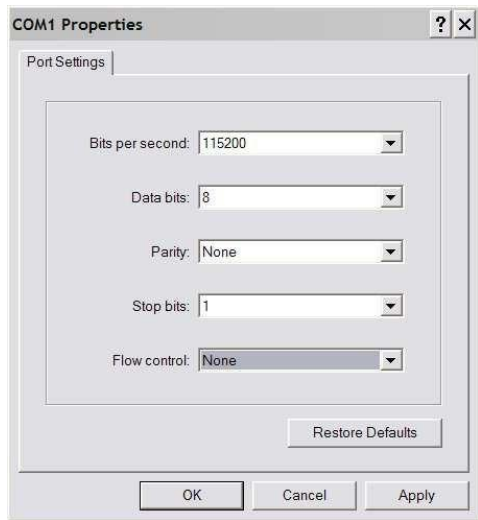

Figure 8. Hyperterminal COM port setup.

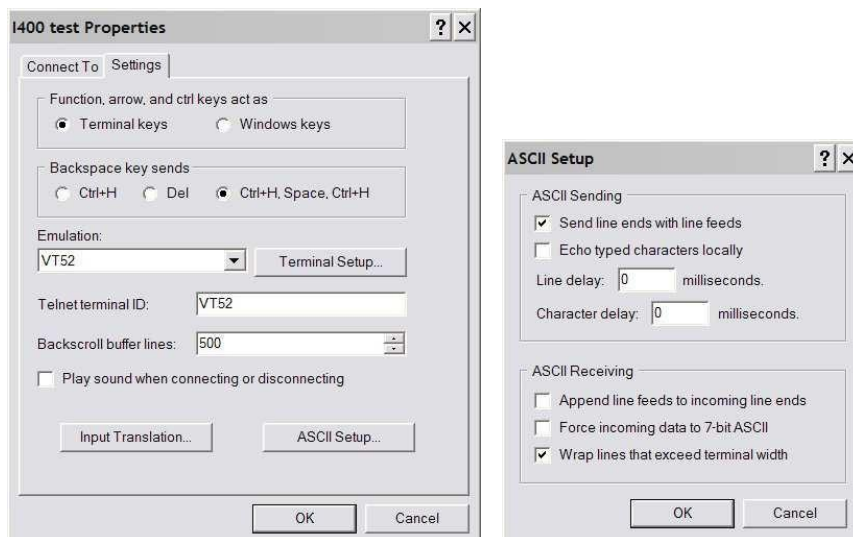

Figure 9. Hyperterminal terminal settings

Type “#?<CR>” to query the active listener. You should get the response “4”. You are communicating successfully with the N2400 at address 4. If you hear your computer’s bell sound when you send the string, the N2400 did not understand it, probably because there was a typing error. If the N2400 does not echo correctly, either the terminal settings or the N2400 switch settings are likely to be wrong. Check them and retry until you see the characters echo correctly. If you make any errors while typing, use the backspace key and re-type from the error.

Type “read?<CR>”. The characters can be upper or lower case. The N2400 will return the state of its digital inputs as four 24-bit numbers. These are respectively the state of the front panel Auto/Man switches, the state of the front panel In/Out switches, the state of the out limit inputs and the state of the in limit inputs.

If you have an actuator connected to channel 1, and it is safe to do so, change it to the energized state by sending “switch 0 1”, meaning set switch 0 (of 0 to 23 switches) to state 1 (energized). Return it to the un-energized state by sending “switch 0 0”. At each stage you can send “read?” to see the response of the limit switches.

Type “*rst<CR>” to reset the N2400. Your unit is functioning correctly and is ready to be integrated into your system.

If you wish to explore the ASCII communication capabilities of the N2400 more fully, refer to the commands list in section 16.

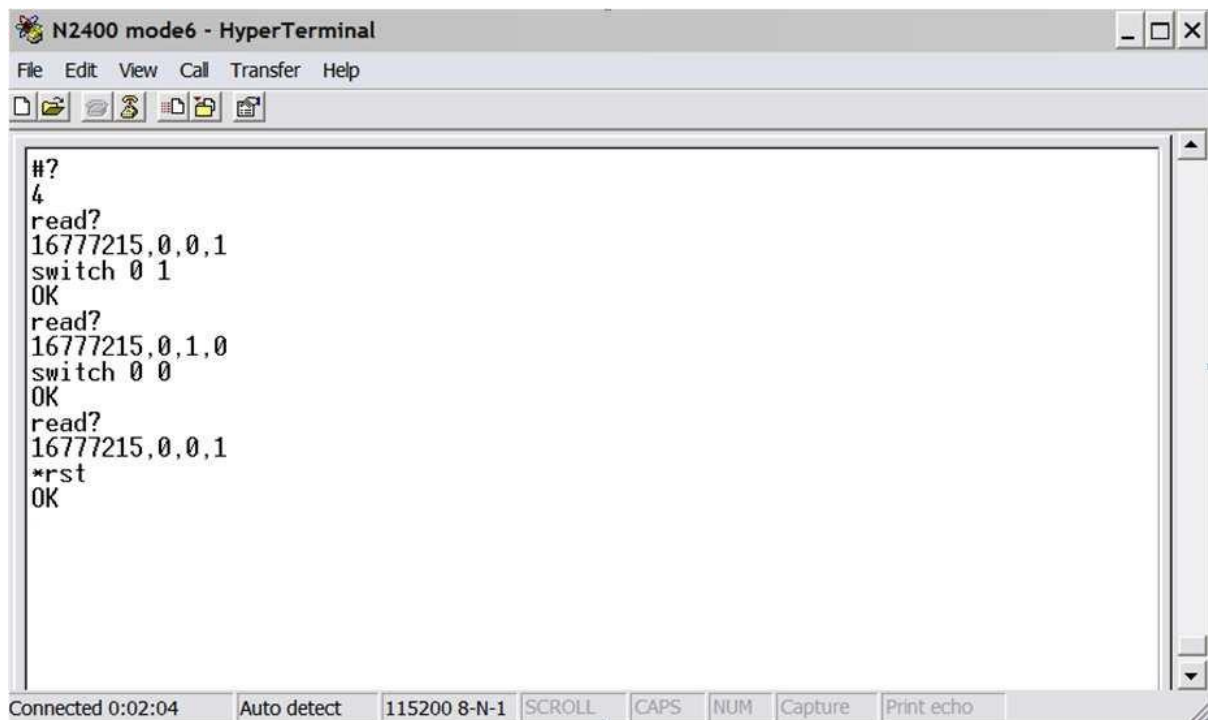

```
#?  
4  
read?  
16777215,0,0,1  
switch 0 1  
OK  
read?  
16777215,0,1,0  
switch 0 0  
OK  
read?  
16777215,0,0,1  
*rst  
OK
```

Connected 0:02:04 Auto detect 115200 8-N-1 SCROLL CAPS NUM Capture Print echo

Figure 10. Example Hyperterminal session (terminal mode)

10 Using the PSI DiagnosticG1 Host Program

Usually you will use a custom application to communicate with the N2400, either one you write yourself using the software interfaces available from Pyramid Technical Consultants, Inc., or one that is supplied by Pyramid. However you can get started immediately using the PSI DiagnosticG1 host program that was supplied with your N2400. It is also available for free download from www.ptcusa.com. The PSI Diagnostic is a stand-alone program which allows you to set and read the actuator states. For some applications it may be adequate for all of your needs.

It is useful to understand what you can do with the PSI Diagnostic, because it exposes all of the functions of the devices it connects to. Application programmers will find it useful to help decide which functions to implement in their host software.

10.1 Installing the PSI Diagnostic Program

Your N2400 was shipped with a USB memory stick with the installation files you need. We recommend that you copy the files into a directory on your host PC. Check the Pyramid Technical Consultants, Inc. web site at www.ptcusa.com for the latest versions. If you have an earlier installation of the PSI Diagnostic, you can update to the latest version by replacing the PTC_Controls.dll and version.xml files in the program directory.

The program runs under the Microsoft Windows operating system with the 3.0 .NET framework or later. This has to be installed before the PSI Diagnostic. Most new PCs have .NET already installed. It can be downloaded from the Microsoft web site at no charge.

Install the PSI Diagnostic by running the PTCDiagnosticSetup.msi installer, and following the screen prompts. Once the program has installed, you can run it at once. It will allow you to connect to the N2400, and, depending upon your setup, multiple additional devices at the same time.

The Diagnostic uses the concepts of ports and loops to organize the connected devices. A port is a communications channel from your PC, such as a COM port, a USB port or Ethernet port. Each port can be a channel to one or more loops, and each loop may contain up to 15 devices.

10.2 Establishing communication with the N2400

Start the PSI Diagnostic. It will search the available ports on your computer and present a search list in an autodetect utility window. Figure 11 shows a case where the program found two serial ports and a network adaptor. We'll work through an example where the connection to the N2400 is via an A500 at IP address 192.168.2.3. We can add this specific address to the network search to avoid the need to broadcast to the whole LAN by typing the address followed by a colon and the standard port number 100, as shown in the figure, and clicking "Add IP".

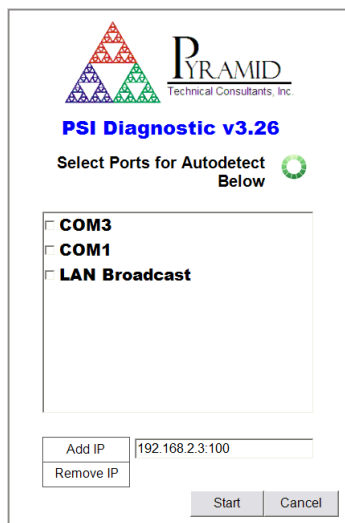

Figure 11. PSI Diagnostic Search Utility – adding a target IP address and port

Check that the target port is checked for inclusion in the search and click the “Start” button. The autodetection process will start (figure 10).

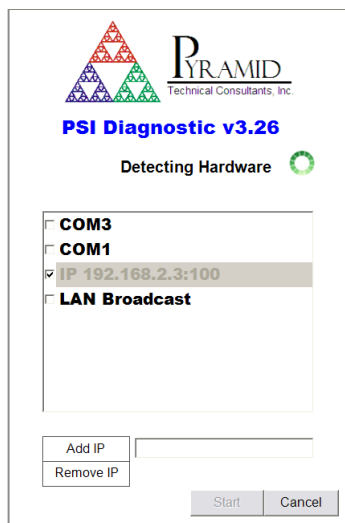

Figure 12. PSI Diagnostic Search Utility – detection in progress

After a few seconds the program should find the N2400 (plus any other devices you have connected). You should see the receive and transmit LEDs illuminate on the N2400 rear panel.

10.3 Data tab

Clicking on the N2400 entry in the explorer list will open the N2400 window (figure 13). The basic interface is very simple. There are switches to set the digital output states, and LEDs which show the digital input states.

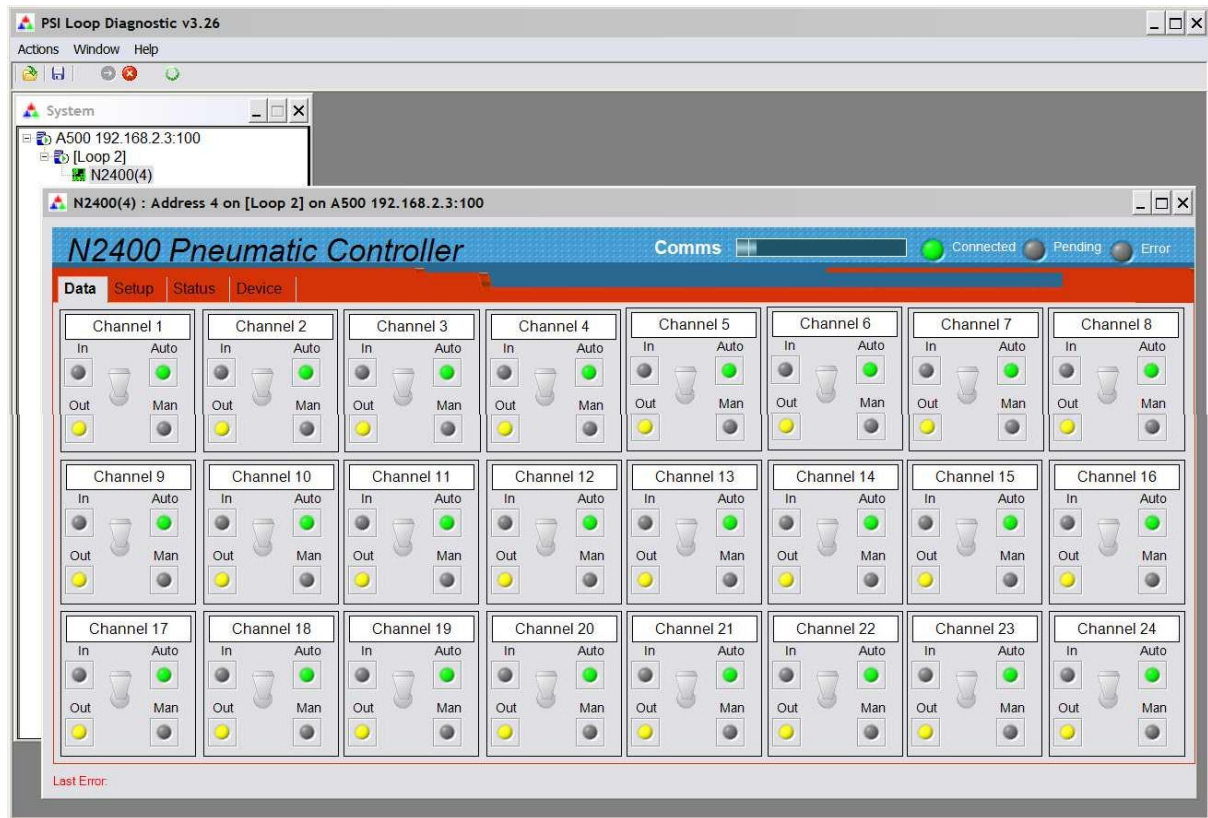

Figure 13. Data tab: A N2400 is connected via an A500 controller, on loop 2 at address 4.

If you have an actuator connected, and it is safe to do so, you can try the controls to see their effect.

Toggle switches	Toggle the switches to set the solenoid outputs. Setting a switch to the down position energizes the relevant output to +24 VDC. A connected actuator should move to the “in” position and the In indicator should then light instead of the Out indicator. The physical LEDs on the N2400 front panel should also change over.
Auto / Man	If the front panel switch for a channel on the N2400 is set to manual, then the indication on the PSI Diagnostic will change from Auto to Man, and the toggle will be grayed out. The actuator position is now controlled from the N2400 front panel, but the limit switch states will still be shown on the Diagnostic.

As an example, figure 14 shows that the channel 1 actuator has been switched to the in position from the Diagnostic host. Channels 2 and 3 have been overridden to manual control from the N2400 front panel, and set to the in and out states respectively.

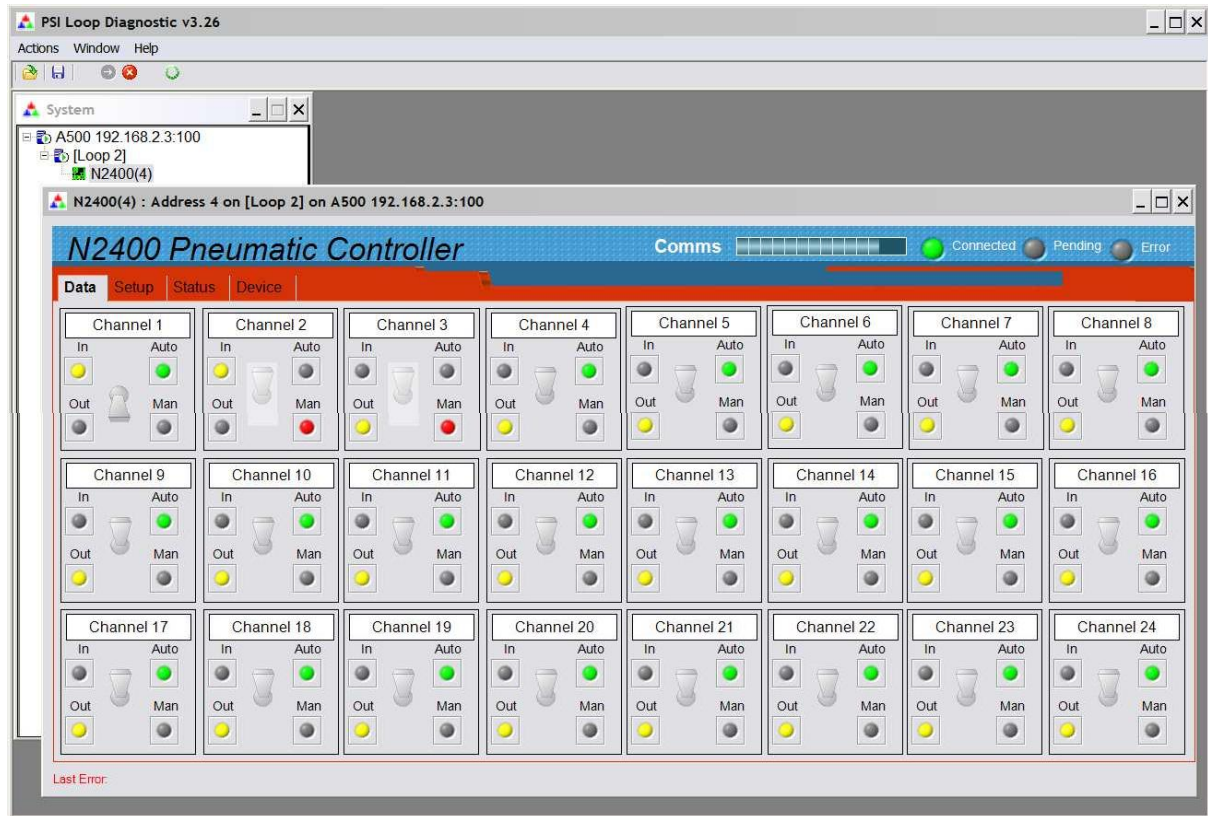

Figure 14. Data tab: various states for channels 1-3.

10.4 Setup tab

There are no setup parameters for the N2400, so the setup tab is blank .

10.5 Device tab

Click on the “Device” tab. You can check the communication link status, read the N2400 manufacturing serial number and verify the versions of the hardware and firmware. On the right is the firmware update utility. You can use this to download firmware updates (.hex files) downloaded from the Pyramid Technical Consultants, Inc. web site.



Figure 15. Device tab, showing firmware update utility controls.

Communication	The counters show details of the communications between the N2400 and its host. You can click the Reset Counters button to reset the fields to zero.
Comm:Term, Comm:Checksum	These controls are used for ASCII communications only. You can ignore them when using the PSI Diagnostic.
Frequency	This parameter is not used by the N2400.
SerialNumber	This is the manufacturing serial number of your device, and should be left unchanged.
Comm:Timeout	This field can be used to control how the N2400 behaves if the communication link to its host is lost. Entering any non-zero integer value sets the number of seconds that the N2400 will continue what it is doing if communications are lost. After that it will go to its defined safe state, which is all outputs unenergized.
Select hex file	This button starts the N2400 firmware update process. It opens a file selection dialog. When you select a hex file it will start uploading to the N2400 immediately. Upon completion the N2400 will restart automatically, and you will see the new Device Version number displayed. See section 14 for more details.
Reset	This button causes a full warm reset of the N2400. All outputs will be set back to off.

11 Other Host Computer Software

The N2400 is supported by the Pyramid PTC DiagnosticG2 software which is required by the A360 and A560 loop controllers. This was supplied with your N2400, or can be downloaded at www.ptcusa.com. The user screens are similar to those shown in the last section for the PSI DiagnosticG1 software.

A convenient and widely-supported means of connecting to a large-scale system is to use the EPICS protocol (<http://www.aps.anl.gov/epics/>). The Pyramid IG2 software is available to connect Pyramid devices to EPICS using the Channel Access Server method. Once the controls and readbacks are exposed to EPICS via IG2, then you can use one of several freely-available packages to deliver the data to a suitable software environment, for example Python, MatLab, C#, C++. Control System Studio is an easy to use interface development tool that is also available to download (<http://controlsystemstudio.org/>).

Circuit overview

The N2400 circuitry is split over three types of printed circuit boards;

- main processor and communications board
- switch board (three, eight channels per board)
- connector board

The following block schematic shows one I/O channel. The I/O components are repeated to give the twenty-four channels.

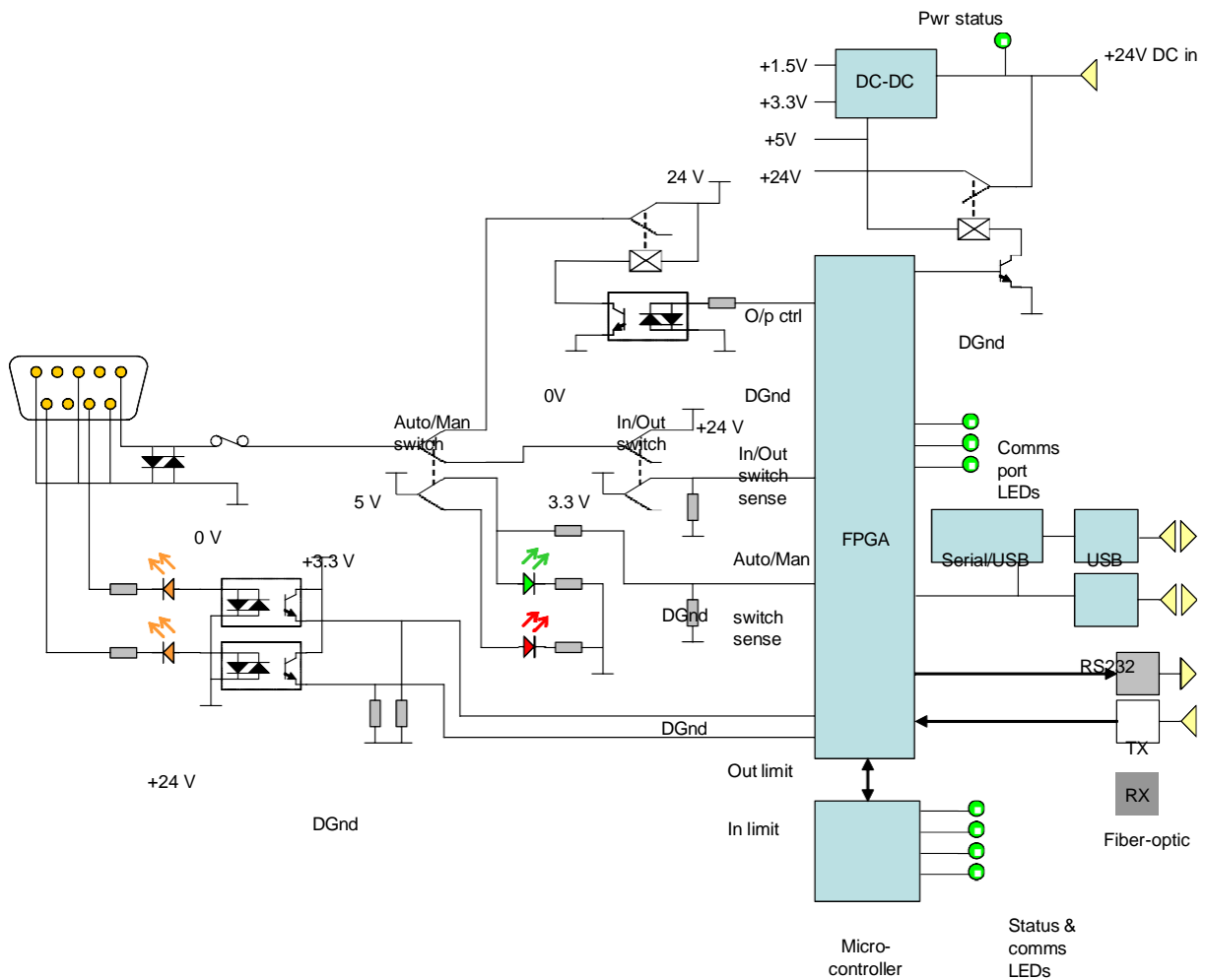

Figure 16. N2400 block schematic.

The power input and conversion is on the main board. The incoming 24 VDC power is split to provide separately fused feeds to the switch boards and to the DC-DC converters that generate 5 V, 3.3 V and 1.5 V rails for the main board. The feeds to the switch boards are gated by a relay which on power-up only closes when the FPGA on the processor board has started up, thus preventing momentary random states of the outputs.

The front panel auto/man switch selects between the relay switched 24 V controlled by the FPGA (and ultimately by the remote host) and 24 V controlled by the front panel in/out switch. The 24 V output is protected by a automatically-resetting thermal fuse. Signals back to the FPGA enable the host software to sense if the channel has been switched to manual, and the state of the In/Out switch, irrespective of whether the channel has been switched to manual.

The limit switch inputs sense when the external circuit is closed to 0V, thus drawing current from the 24 V supply through the photodiodes and indicator LEDs. 5 kohm series resistors limit the current that will flow through the remote switches to about 4.5mA.

The field programmable gate array (FPGA) handles all input output and communications in association with the microcontroller.

12 Connectors

12.1 Rear panel connectors

12.1.1 Actuator control and readback

Twenty-four nine pin Dsub female.

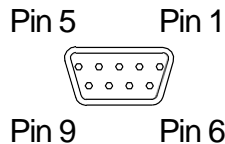

(External view on connector / solder side of mating plug)

1	Switched 24 VDC out	6	24 V return (0V)
2	n/c	7	Limit "In" opto input
3	24 V return (0V)	8	n/c
4	n/c	9	Limit "Out" opto input
5	24 V return (0V)		

12.1.2 Power input

2.1 mm threaded jack. To mate with Switchcraft S761K or equivalent

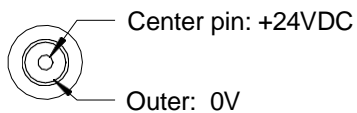

12.1.3 Fiber-optic communications

ST bayonet. To mate with ST male terminated fiber optic cable. Recommended cable types 1 mm plastic (such as Avago HFBR-EUS-500) or 200 μ m silica (such as OCS BC03597-10 BL). Signal: 650 nm light (red).

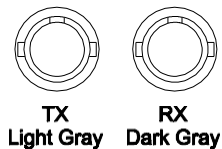

12.1.4 USB communications

USB type B female.



12.1.5 RS-232 communications

Six pin mini-DIN socket (PS/2 mouse/keyboard type).

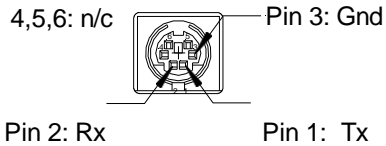

(External view on connector / solder side of mating plug)

The connector includes a sensor for cable connected.

12.2 Alternative actuator connections (N2400-D25 model)

12.2.1 Actuator control

Two twenty-five pin Dsub female (J1, J2).

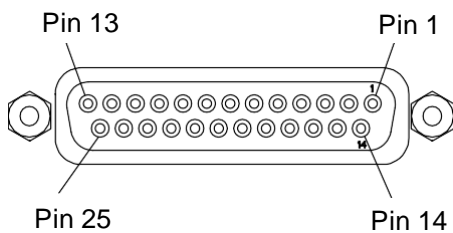

(External view on connector / solder side of mating plug)

1	Switched 24 VDC out 1 (13)	14	24 V rtn
2	Switched 24 VDC out 1 (13)	15	24 V rtn
3	Switched 24 VDC out 1 (13)	16	24 V rtn
4	Switched 24 VDC out 1 (13)	17	24 V rtn
5	Switched 24 VDC out 1 (13)	18	24 V rtn
6	Switched 24 VDC out 1 (13)	19	24 V rtn
7	Switched 24 VDC out 1 (13)	20	24 V rtn
8	Switched 24 VDC out 1 (13)	21	24 V rtn
9	Switched 24 VDC out 1 (13)	22	24 V rtn
10	Switched 24 VDC out 1 (13)	23	24 V rtn
11	Switched 24 VDC out 1 (13)	24	24 V rtn
12	Switched 24 VDC out 1 (13)	25	24 V rtn
13	Shield		

12.2.2 Limit switch readback

Four twenty-five pin Dsub female (J3-J6).

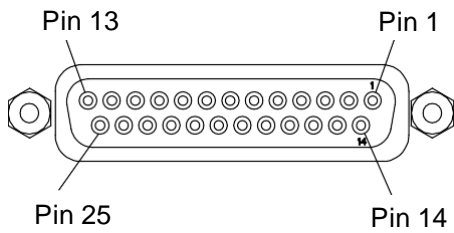

(External view on connector / solder side of mating plug)

1	Limit in 1 (7, 13, 19)	14	24 V rtn
2	Limit out 1 (7, 13, 19)	15	24 V rtn
3	Limit in 2 (8, 14, 20)	16	24 V rtn
4	Limit out 2 (8, 14, 20)	17	24 V rtn
5	Limit in 3 (9, 15, 21)	18	24 V rtn
6	Limit out 3 (9, 15, 21)	19	24 V rtn
7	Limit in 4 (10, 16, 22)	20	24 V rtn
8	Limit out 4 (10, 16, 22)	21	24 V rtn
9	Limit in 5 (11, 17, 23)	22	24 V rtn
10	Limit out 5 (11, 17, 23)	23	24 V rtn
11	Limit in 6 (12, 18, 24)	24	24 V rtn
12	Limit out 6 (12, 18, 24)	25	24 V rtn
13	Shield		

13 Controls and Indicators

13.1 Front panel controls and indicators

Twenty-four identical control and indicator clusters.

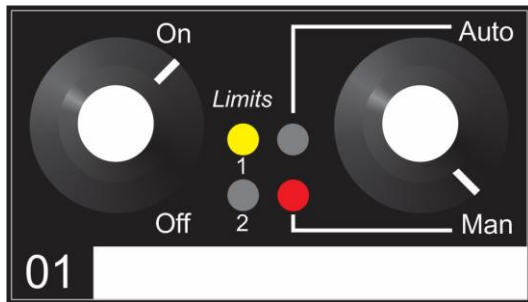

Figure 17. Actuator channel control and indicator cluster

13.1.1 In/Out switch

Rotary switch which is effective if the channel is in manual mode. Up position to energize the relevant output, down position to de-energize the output. The host software can read the position of the In/Out switch irrespective of the state of the Auto/Man switch.

In early models of the N2400, this control was a toggle switch.

13.1.2 Auto/Man switch

Rotary switch to put the relevant channel in auto (up position: software control from the host computer) or manual (down position: control from front panel) control. The host software can read the position of the switch, and thus knows whether or not it can control the actuator position.

In early models of the N2400, this control was a locking toggle switch. Pull the locking sleeve against the spring pressure to release the lock.



You should take care when switching between auto and manual mode, as the actuator may move, depending upon the relative states of the host control and the In/Out switch.

13.1.3 Auto indicator

Green LED. Illuminates when the channel is in auto mode.

13.1.4 Man indicator

Red LED. Illuminates when the channel is in manual mode.

13.1.5 In indicator

Orange LED. Illuminates when the “in” digital input is connected to 0V by a remote limit switch.

13.1.6 Out indicator

Orange LED. Illuminates when the “out” digital input is connected to 0V by a remote limit switch.

13.2 Rear panel controls**13.2.1 Mode switch**

Communications mode.

Setting	Function
0	9 bit binary, 10 Mbps
1	8 bit binary, 3 Mbps
2	8 bit binary, 115.2 kbps
3	8 bit binary, 57.6 kbps
4	8 bit binary, 19.2 kbps
5	ASCII, 3 Mbps
6	ASCII, 115.2 kbps
7	ASCII, 57.6 kbps
8	ASCII, 19.2 kbps
9	(Reserved)

13.2.2 Address switch

16 position rotary switch setting device address. Choice of address is arbitrary, but each device in a fiber-optic loop system must have a unique address.

Setting	Function
0	(Reserved to loop controller)
1-F (decimal 1 to 15)	Available address settings.

13.3 Rear panel indicators**13.3.1 Power**

Green LED. On = 24 VDC input power is present

13.3.2 Xmit







Green LED. On = N2400 is sending messages.

13.3.3 Rcv

Green LED. On = N2400 is receiving messages.



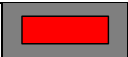

13.3.4 Status

Red/Green LED. This LED indicates a variety of internal states, as follows:

	Alternating red/orange/green/off	Unit powering up
	Off	Unit idle (not measuring)
	Orange	Waiting for trigger; or resetting integrators
	Green	Measuring
	Red	Error
	Alternating green/orange	Downloading program from host

13.3.5 Link

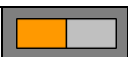
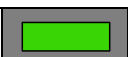
Red/Green LED. This LED indicates a variety of communication states, as follows:

	Alternating red/orange/green/off	Unit powering up
	Off	No connection since last power-up.
	Alternating green/off	Unconnected
	Alternating orange/off	Unconnected; unit has gone to the safe state.
	Green	Connected
	Red	Fatal communications error
	Fast alternating green/orange	Boot state (waiting start command or code download)

14 Software updates

The N2400 has three embedded firmware releases.

Firmware	Function
FPGA (.pof file)	General logic, loop message passthrough
PIC Boot (.hex file)	Boot up, code upload
PIC Application (.hex file)	Main application; special functions, SCPI instrument model.

The FPGA and PIC microcontroller boot code should not require updating. They require access to the circuit board and dedicated programming tools to load new code. If either of these codes need to be updated, your supplier will contact you and make arrangements either to return the unit for upgrade, or to have an engineer perform the upgrade for you.

The PIC microcontroller application code may be updated periodically to add new operating features. New code releases will be provided by your supplier, or can be downloaded from the Pyramid Technical Consultants, Inc. website. The hex file can be loaded using the PSI Diagnostic host without any need to access the unit. The upload can be performed directly from the PC host. On the Device tab, click the “Select .hex file” button and navigate to the relevant file. The code will then load. The process takes about 20 seconds, and the N2400 will start running the new code immediately.

A future FPGA code revision may introduce uploadable FPGA code. In this case, there will be a .fhex file which will be loaded in a similar manner to the PIC application code.

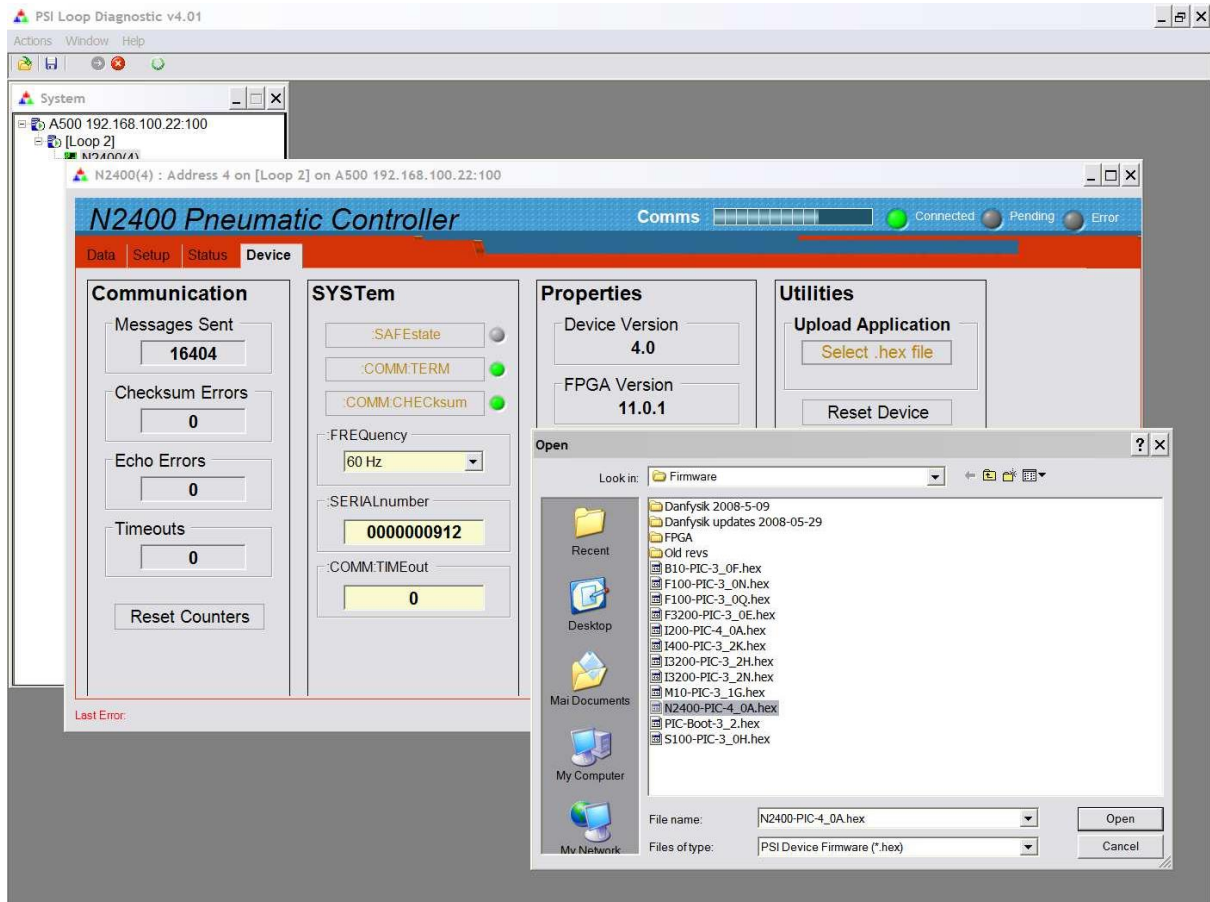

Figure 18. Selecting the hex file to load.

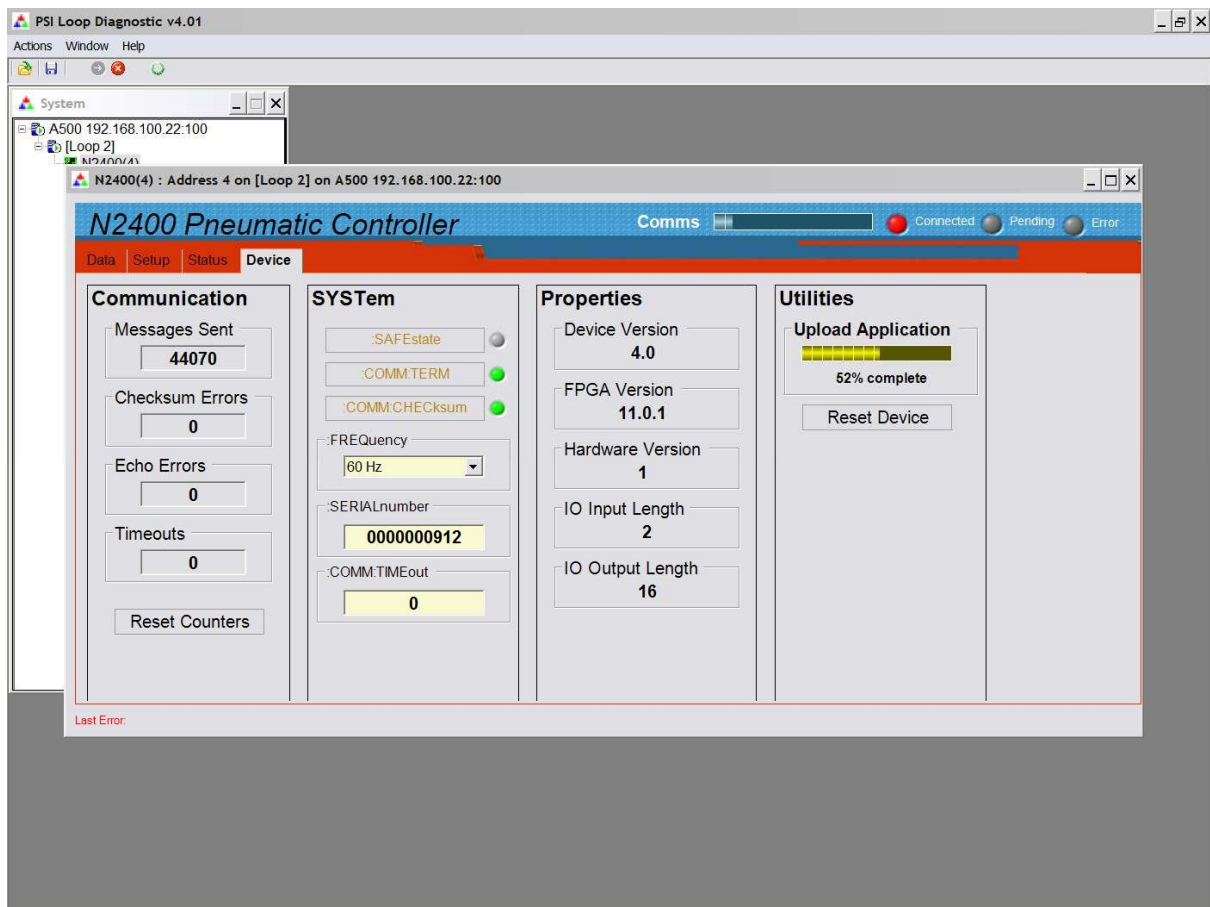

Figure 19. Firmware upload in progress.

15 Safety Interlocks

15.1 Safety relay interlock circuit

The N2400 is not designed for sole use on critical safety systems. Most safety standards require simple hardware-only systems with special safety-rated relays to handle critical safety interlocks. This can be handled in a system based on the N2400 by introducing a safety interlock circuit between the N2400 and the actuator.

As an example, consider a safety requirement that two actuators must be de-energized if 24 VDC interlock signals are not present on two independent circuits. Figure 20 shows an example circuit using safety relays. Two separate interlock signals are required to be present before the actuator control signal from the N2400 is allowed to pass through the circuit. Otherwise the control lines are connected to N2400 0V so that the actuators are disabled. Zener diodes on the interlock signal inputs ensure that those signals have to reach a clean “high” condition before the interlock is seen as good.

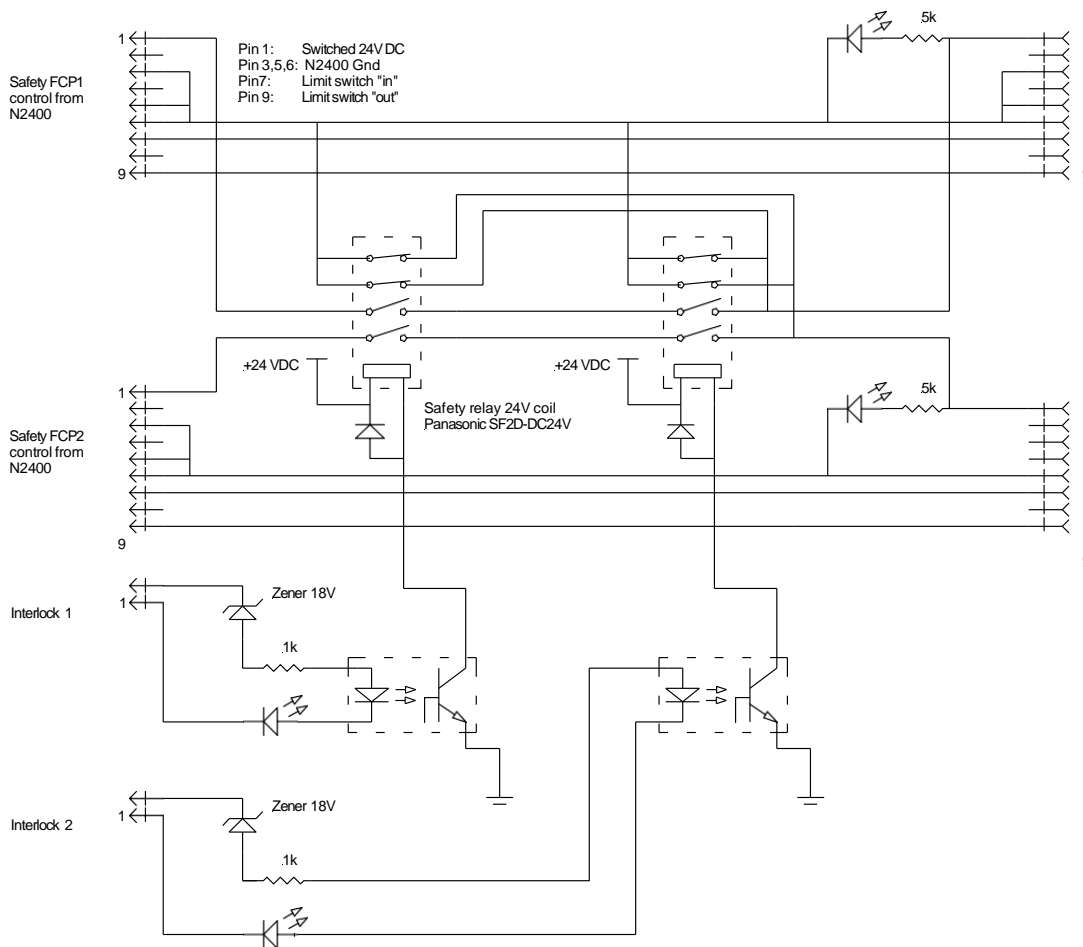

Figure 20. Example safety circuit

15.2 Lock out / Tag out

Lock out / tag out (LOTO) procedures should be followed if unexpected actuator movements could cause hazard to service staff. The person working on the actuator system must be able to disable the drive with a suitable lock bearing his or her name, and keep the key until the work is completed.

Any service staff working on an actuator system under LOTO procedures should disconnect the lead coming from the N2400 at the actuator itself, where they can see that it is disconnected while working. If this is not possible, the cable should be disconnected at the N2400 and the cable end secured inside a lock box. As a further precaution, the pneumatic pressure could be removed.

16 ASCII Communication

16.1 ASCII Protocol – SCPI

The PSI Diagnostic and most user host applications will use the 9 bit binary communications mode of the N2400, as this provides the highest performance. However ASCII communications may be needed by some users for better compatibility with existing systems. The N2400 supports ASCII communications under the Standard Commands for Programmable Instruments (“SCPI”) protocol which is widely used for instrumentation.

SCPI is an extension of the IEEE 488.2 standard. This was originally developed by Hewlett-Packard for the HP-IB (later GP-IB) interface before being adopted by the IEEE, and is widely used by manufacturers of measurement equipment. The N2400 implements the 1999.0 revision of SCPI (© 1999 SCPI Consortium).

16.1.1 Messages

The first bit of every eight bit group in a message is the start bit, followed by seven bits encoding a character from the ASCII character set.

A full command from the host to the N2400 comprises as many ASCII characters as needed to form the message, terminated by the LF (0x0A) character. The N2400 will not start to process a command until the 0x0A character is received. The list of valid commands is listed in the next section. If the communications is being handled in a terminal session, the terminal program should send CR (0x0d) before the LF to get a legible display. The CR is ignored by the command interpreter in the N2400.

The N2400 generates a reply to every message from the host when it is the listener. The first byte of its reply will always be a single non-printing character. The first character is ACK (0x06) when the command has been successfully executed with no errors. Responses to host commands with a ‘?’ will then have the required data, terminated with the CR,LF sequence. If the host is not requesting data (no “?”), no other bytes will be transmitted after the ACK. If the N2400 generates an error when executing the host command, it will transmit a single BELL (0x07) as its response. A computer running a terminal program will therefore “beep” when the N2400 cannot execute a command, for example due to incorrect syntax. A more interactive “terminal mode” can be selected which modifies this behavior to make the N2400 more user-friendly when it is being driven from a terminal program.

Device addressing is performed using the special command ‘#’. Addressing is only necessary for devices linked by a fiber-optic loop, but a device is made the “listener” when the host sends #ADDRESS. For example, #4 will make the device with address 4 the listener. You must ensure that all devices on the same communications channel have unique addresses. All subsequent commands sent (without address) will be listened and responded to by device 4 only. The host message #? asks who the listener is. The # command can be sent as a compound message, such as #3;*IDN?.

16.1.2 Status registers

The N2400 implements the IEEE 488.2 status register method. Each of the registers is masked by a corresponding enable register. It is recommended that you set all the enable registers to all 1's. The host software should use the *STB? command to watch for changes to the status of the N2400, and then *ESR?, :STATus:OPERation:CONDition? or :STATus:QUESTionable:CONDition? as appropriate to recover the details from the relevant register.

16.1.3 Host Commands

The N2400 responds to the mandatory commands prescribed by SCPI and IEEE 488.2, plus specific commands as required by the operation of the device. The commands are grouped with a hierarchical structure, with the levels separated by the colon character. For example:

```
SYSTem:COMMunication:CHECKsum 1
```

This command sets the checksums for all replies from the N2400.

SCPI provides for a long and short form for each command. The short forms are indicated by the capitalized part of the command. { } denotes a required argument, [] denotes an optional argument.

A number of commands are password protected to reduce the chance of changing them accidentally. The commands only effective after the device has been rebooted if they have been enabled by first sending

```
SYSTem::PASSword 12345
```

Sending any other number as the argument of this command disables the protected commands again.

16.1.3.1 ADDRESSING DEVICES

SCPI does not provide specific commands for addressing multiple devices, because this was handled by hardware in the original IEEE 488.1 specification. The N2400 provides a simple mechanism for making any device on the loop the listener. The device will remain the listener until another device is selected.

```
# {address} // Make device address (1 to 15) the listener
#? // Query which device is listener.
```

16.1.3.2 IEEE 488.2 MANDATORY COMMANDS

Commands which have a query equivalent for readback are marked with “(?)” in the following table

Parameters are generally passed to the N2400 with the set version of the command, but no parameters are passed for the query version. For example,

*ESE 3 // set the Event Status Enable register to 0000011

*ESE? // query the Event Status Enable register

*CLS		Clear Status Command. Clear all event registers and the error queue
*ESE	(?)	Program (query) the state of the Event Status Enable register. 8 bits. N2400 returns decimal value.
*ESR?		Standard Event Status Register Query. Query the state of the Event Status register. N2400 returns decimal value.
*IDN?		Identification Query. N2400 returns manufacturer, model number, serial number, firmware version
*OPC	(?)	Set (query) the Operation Complete bit in the Standard Event Status Register after all pending commands have been executed. Not currently supported.
*RST		Reset Command. Return the device to the *RST default conditions.
*SRE	(?)	Program (query) the Service Request Enable register. Not currently supported.
*STB?		Read Status Byte Query. Query the Status Byte Register. N2400 returns decimal value.
*TST?		Self-Test Query. Perform a checksum test on ROM and return the result. N2400 returns <1>.
*WAI		Wait-to-Continue Command. Wait until all previous commands are executed. Not currently supported.

16.1.3.3 IEEE 488.2 OPTIONAL COMMANDS

*RCL					Recall instrument state from EEPROM
*SAV					Save present instrument state to EEPROM

16.1.3.4 N2400 COMMANDS

N2400 set commands which have a query equivalent for readback are marked with “(?)” in the following table.

<i>Command</i> (?) = query command				<i>Command arguments</i>	<i>Query returns</i>	<i>Meaning</i>
FETCh?					Auto/Man switch settings, In/Out switch settings, out limits, in limits (24 bit values)	Read digital inputs Auto/Man: FFFFFFFF = all channels in auto In/Out: FFFFFFFF = all channels set to in Out limits: FFFFFFFF = all out limits set In limits: FFFFFFFF = all in limits set
READ?					Auto/Man switch settings, In/Out switch settings, out limits, in limits (24 bit values)	Read digital inputs Auto/Man: FFFFFFFF = all channels in auto In/Out: FFFFFFFF = all channels set to in Out limits: FFFFFFFF = all out limits set In limits: FFFFFFFF = all in limits set
STATus	:OPERation	:CONDition?				Query operation register status condition bit
		:ENABle	(?)			Set (query) operation register status enable bit
		:EVENT?				Query operation register status event bit
	:QUESTionable	:CONDition?				Query questionable register status condition bit
		:ENABle				Set (query) questionable register status enable bit
		:EVENT?				Query questionable register status event bit
SWITCh				Channel number (0-23), output setting {0 1}		Set actuator output for relevant channel 0 = off 1 = on
SWITCh?				Channel number (0-23)	Output setting {0 1}	Query actuator output for relevant channel
SYSTem	:COMMunication	:CHECKsum		Checksum enable {0 1}		Set appending checksum to all replies (password protected) 0 = off

						1 = on
		:IDENTIFY?			Identify response	Sends chained identify command. Devices in the loop combine to assemble the response <number of devices in loop, addr of first device, addr of second device, addr of last device>
		:TERMinal	(?)	Terminal mode {0 1}	Terminal mode setting	Set (query) terminal mode (password protected) 0 = terminal mode off 1 = terminal mode on In terminal mode, ACK and NACK are not sent, and "OK" or error response is sent for all valid commands that do not otherwise generate a response.
		:TIMEout	(?)	Timeout in seconds {<timeout>}	Timeout in seconds	Set (query) timeout in seconds (password protected); 0 = timeout disabled. N2400 will go to unconnected state if no valid message is received in the timeout period.
	:ERRor?					Query the next error in the error event queue.
	:FREQUENCY			Frequency in Hz {<Hz>}		Not used by the N2400..
	:PASSword		(?)	Password string {<pass>}	Password string	Set (query) the administrator password <pass> to allow access to protected functions. The default is <12345>.
	:SAFEstate		(?)	Safestate enable {0 1}	Safestate enable setting	Set (query) whether the N2400 goes to the safe state when unconnected. 0 = do not go to safe state 1 = go to safe state Safe state is all outputs off.
	:SERIALnumber		(?)	Serial number string {<serial>}	Serial number string	Set (query) the serial number <serial> of the N2400, max 10 alphanumeric characters. Password protected.
	:VERSion?				SCPI version string	Query the SCPI standard version

16.2 ASCII Protocol – Terminal Mode

SCPI is not ideal for a user trying to control the N2400 from a terminal program. A more interactive terminal mode can be turned on by sending the command

`SYSTEM:COMMunication:TERMinal 1`

After this command is executed, the N2400 will provide a response to every command. Valid query commands will get their normal reply. Other commands will generate an <OK> response if they were interpreted without errors, or an error message if they could not be interpreted. The non-printing ACK and BEL characters are not sent.

17 Fault-finding

Symptom	Possible Cause	Confirmation	Solution
Actuator does not change position when commanded	Channel is set to manual control	Check N2400 front panel	Set switch correctly
	Actuator solenoid incorrectly polarized	Check wiring	Correct wiring as necessary
	Pneumatic pressure low	Check gas pressure	Ensure adequate gas pressure
	Independent interlock circuit is blocking the control signal	Check interlock status	Clear interlock conditions
	Actuator is not connected to that N2400 channel	Check cabling	Correct cabling as necessary
Limit switch indications do not reflect actuator position	Switches are wired n/c instead of n/o	Check switch wiring	Correct wiring as necessary
	Switch wiring swapped end for end	Check switch wiring	Correct wiring as necessary
Actuator movement is the opposite of expected	Pneumatic connections are swapped	Check pneumatic connections	Correct pneumatics as necessary
Multiple of four or eight channels out of twenty-four do not function.	Internal ribbon cable from main board to switch board or connector board is unconnected.	Check internal ribbon cables are in place	Connect ribbon cables as necessary.
Unable to communicate with device	Duplicate address setting	Check address against expected address in host	Use correct switch setting. Switches can be changed

		software.	while the unit is operating.
	Communication link timeout	Network LED not lit.	Investigate and fix communications issue. Use a longer timeout setting if necessary.
	RX and TX cables cross connected somewhere in loop.	Network LED not lit.	Correct cabling.
	Fiber optics are damaged	Inspect fibers, especially the connectors. Check light can be seen through fiber. Exchange fibers and retry	Fit new fibers or re-terminate as necessary.
	Incorrect setting of mode switch		Use correct switch setting. Switches can be changed while the unit is operating.
	RS-232 or USB connector is inserted when trying to communicate on fiber optics	Check connections to rear panel.	Remove cables for unused interfaces
Device loop address not as expected	Address switch not at a valid setting	Move switch to another address and back to required address	Ensure switch is correctly set
Communications interruptions	Other processes on PC host interfering with comms ports.		Use a dedicated PC with simple configuration and minimum number of processes running.
PSI Diagnostic will not connect to devices	Two copies of program running		Run a single instance only

18 Maintenance

The N2400 does not require routine maintenance or calibration. Every six months at minimum you should confirm that the cooling fan is not blocked, and remove any accumulated dust.

The N2400 is fitted with a 2.5 A automatically resetting positive temperature coefficient (PTC) fuse in the 24 VDC input, and 100 mA fuses on each actuator output. No user intervention is required if the fuse operates due to overcurrent. The fuse will reset when the overcurrent condition ends.

19 Support

Manual and software driver updates are available for download from the Pyramid Technical Consultants website at www.ptcusa.com. Technical support is available by email from support@ptcusa.com. Please provide the model number and serial number of your unit, plus relevant details of your application.

20 Returns procedure

Damaged or faulty units cannot be returned unless a Returns Material Authorization (RMA) number has been issued by Pyramid Technical Consultants, Inc. If you need to return a unit, contact Pyramid Technical Consultants at support@ptcusa.com, stating

- model
- serial number
- nature of fault

An RMA will be issued, including details of which service center to return the unit to.

21 Disposal

We hope that the N2400 gives you long and reliable service. The N2400 is manufactured to be compliance with the European Union RoHS Directive 2002/95/EC, and as such should not present any health hazard. Nevertheless, when your device has reached the end of its working life, you must dispose of it in accordance with local regulations in force. If you are disposing of the product in the European Union, this includes compliance with the Waste Electrical and Electronic Equipment Directive (WEEE) 2002/96/EC. Please contact Pyramid Technical Consultants, Inc. for instructions when you wish to dispose of the device.

22 Declaration of Conformity

Declaration of Conformity

Issued by: Pyramid Technical Consultants, Inc.
1050 Waltham Street, Lexington MA 02421, USA

The undersigned hereby declares, on behalf of Pyramid Technical Consultants, Inc. that the referenced product conforms to the provisions as listed. Refer to the document: *Extension of testing and analysis to the PTC product line, December 10, 2007* and the *I400 Technical Construction File* for detailed testing information.

Product: N2400 actuator controller

Year of initial manufacture: 2007

Applicable Directives: 73/23/EEC Low Voltage Directive:
Laws for electrical equipment within certain voltage limits

89/336/EEC – EMC Directive:
Laws relating to electromagnetic compatibility

Applicable Standards: IEC 610101:2002 (2nd Edition)
UL 61010-1:2004
EN 61326: 1997+A1:1998+A2:2001
EN 55011:1998, A2:2002
EN 61000-6-2:2001 – Electromagnetic Compatibility
Generic Standard, Immunity for Industrial Applications

Issuing Agencies: Safety: TUV Rheinland North America.
12 Commerce Rd, Newtown, CT 06470 USA

EMC: TUV Rheinland North America.
12 Commerce Rd, Newtown, CT 06470 USA

Applicable Markings: TUV, FCC, CE

Authorized by: R. P. Bann
President, Pyramid Technical Consultants, Inc.

Date: July 29, 2008

The Technical Construction File required by these Directives are maintained at the offices of Pyramid Technical Consultants, Inc, 1050 Waltham Street, Lexington MA 02421, USA
A copy of this file is available within the EU at the offices of Pyramid Technical Consultants Europe, Ltd, 2 Chanctonbury View, Henfield BN5 9TW, United Kingdom.

23 Revision History

The release date of a Pyramid Technical Consultants, Inc. user manual can be determined from the document file name, where it is encoded yymmdd. For example, B10_UM_080105 would be a B10 manual released on 5 January 2008.

<i>Version</i>	<i>Changes</i>
N2400_UM_081027	First general release
N2400_UM_140606	Corrections Add table of figures Changes to cover revision 2 hardware including front panel switch changes and optional rear panel with D25 connectors. Add section of G2 Diagnostic and IG2/EPICS.
N2400_UM_250805	Updated address and removed outdated references.