

**LYVYN**

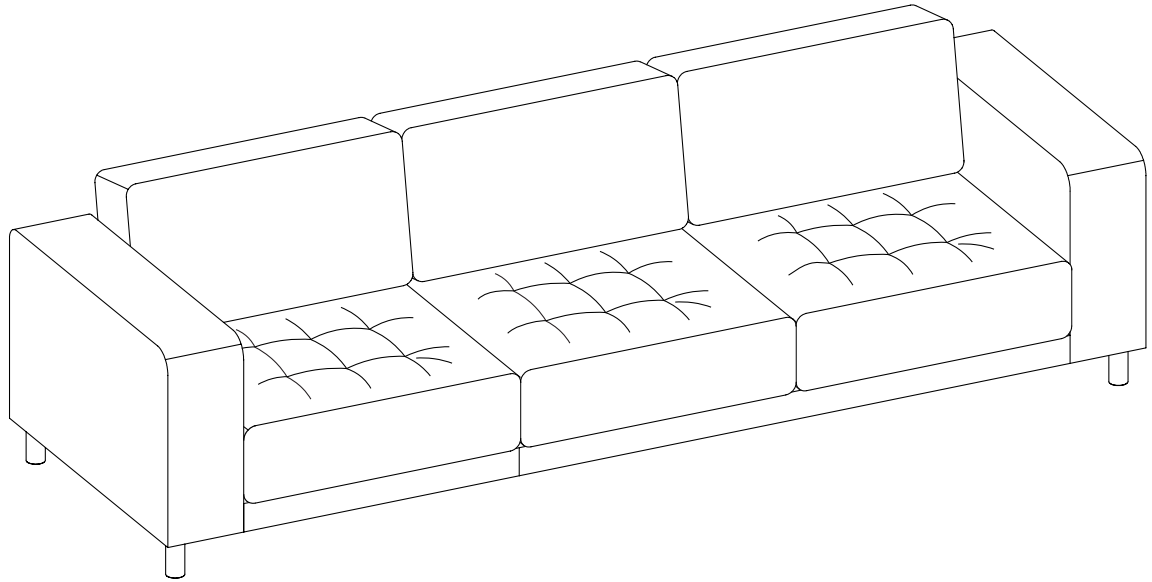

**MYCS**



MYCS





## ACHTUNG

Beschläge nicht in Reichweite von Kindern aufbewahren. Kinder sollten sich stets in einem ausreichenden Sicherheitsabstand zum Aufbau aufhalten. Für einen korrekten und sicheren Aufbau benutzen Sie bitte ausschließlich der Lieferung beiliegende Originalbeschläge und Materialien. Stellen Sie dieses Möbelstück bitte ausschließlich auf festen, ebenen Untergrund. Setzen Sie Ihr Möbelstück weder großer Hitze noch direktem Sonnenlicht aus, um Farbveränderungen zu vermeiden. Ziehen oder schieben Sie Ihr Möbel nicht über den Boden, um Kratzer und andere Schäden am Möbel sowie auf dem Fußboden zu vermeiden. Reinigen und pflegen Sie den Bezug Ihrer Polstermöbel ausschließlich nach den Pflegehinweisen auf dem Etikett.







## WARNING

Keep fittings out of children's reach and keep children away from the construction area. For safe assembly, use only the fittings and furniture elements delivered with your furniture. Place your furniture on firm, level ground. Avoid exposing your furniture to heat or direct sunlight as this can cause the colour to fade. Don't pull or drag your furniture. Clean your textile furniture according to the description on the tag.

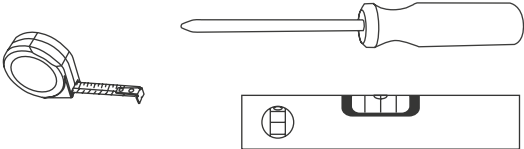
Beschläge nicht in Reichweite von Kindern aufbewahren. Kinder sollten sich stets in einem ausreichenden Sicherheitsabstand zur Montage aufhalten. Für eine korrekte und sichere Montage benutzen Sie bitte ausschließlich der Lieferung beiliegende Originalbeschläge und Materialien. Stellen Sie dieses Möbelstück bitte ausschließlich auf festen, ebenen Untergrund. Setzen Sie Ihr Möbelstück weder grosser Hitze noch direktem Sonnenlicht aus, um Farbveränderungen zu vermeiden. Ziehen oder schieben Sie Ihr Möbel nicht über den Boden, um Kratzer und andere Schäden am Möbel sowie auf dem Fussboden zu vermeiden. Reinigen und pflegen Sie den Bezug Ihrer Polstermöbel ausschliesslich nach den Pflegehinweisen auf dem Etikett.

## AVERTISSEMENT

Gardez les ferrures hors de portée des enfants. Les enfants doivent rester à une distance de sécurité raisonnable lors de la réalisation du montage des meubles. Pour un montage correct et en toute sécurité, veuillez n'utiliser que les ferrures et pièces livrées avec le meuble. Veuillez installer ce meuble uniquement sur un sol stable et plat. Évitez d'exposer vos meubles à la chaleur ou à la lumière directe du soleil car cela peut affadir la couleur. Veuillez ne pas tirer ou traîner vos meubles pour éviter de rayer ou d'endommager vos meubles ou votre sol. Nettoyez vos meubles textiles conformément à la description figurant sur l'étiquette.

	
<b>901.551.05</b> M5X20 	<b>902.100.18</b> 
<b>901.551.07</b> M8X20 	<b>901.551.09</b> 
	<b>901.551.10</b> 

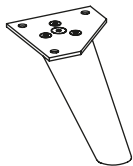

551.158.xx

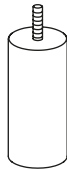

551.159.xx

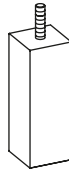

551.160.xx

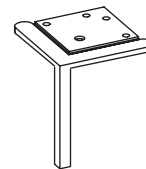

551.166.xx

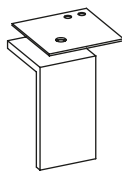

551.164.xx

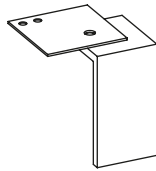

551.165.xx

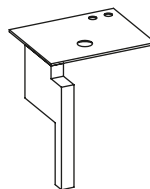

551.162.xx

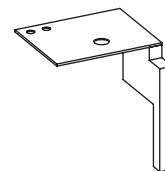

551.163.xx

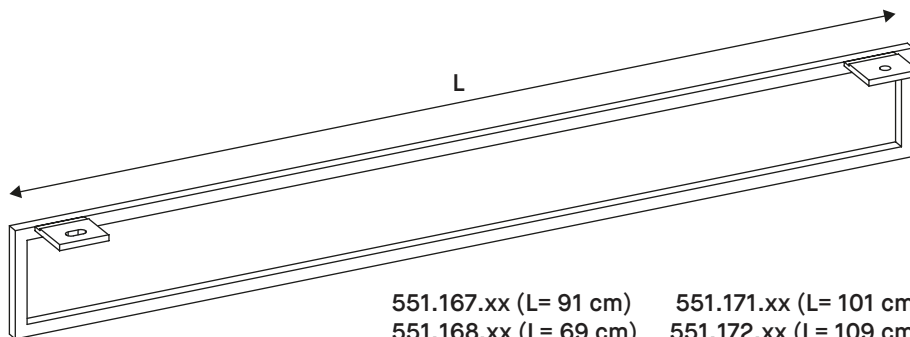

551.167.xx (L= 91 cm)  
 551.168.xx (L= 69 cm)  
 551.169.xx (L= 81 cm)  
 551.170.xx (L= 89 cm)

551.171.xx (L= 101 cm)  
 551.172.xx (L= 109 cm)  
 551.173.xx (L= 121 cm)  
 551.174.xx (L= 55 cm)



551.175.00



1.

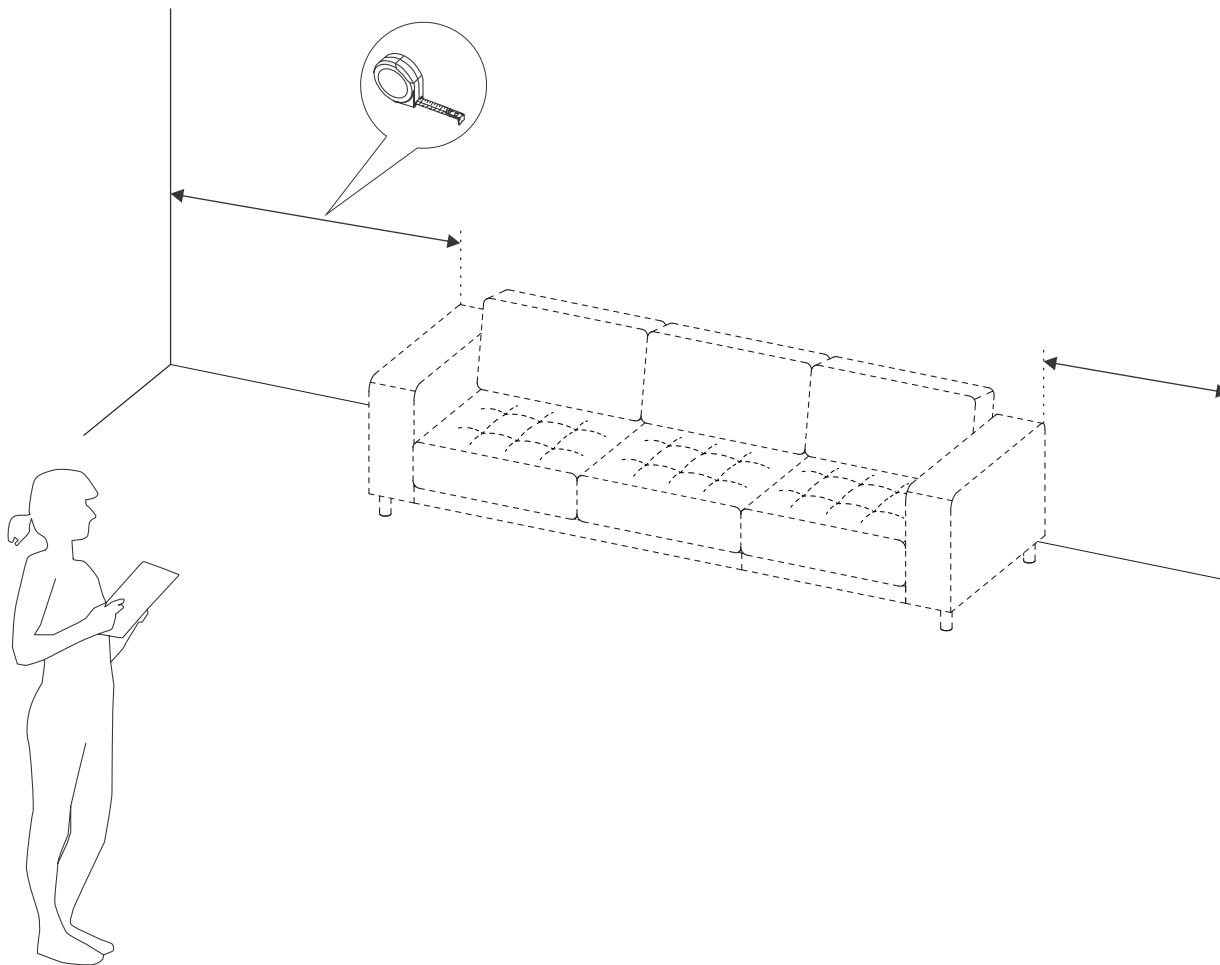

# 2.

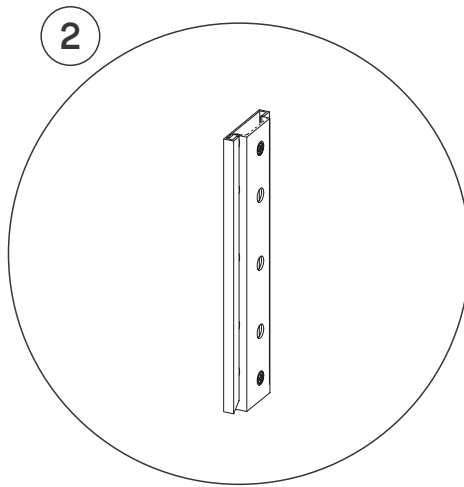
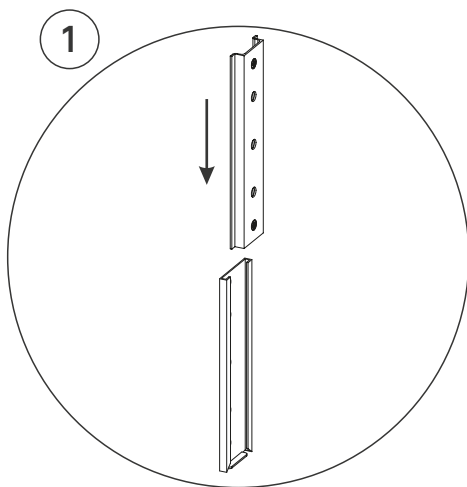
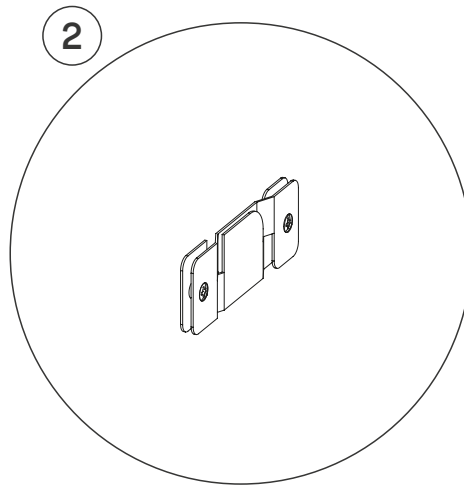
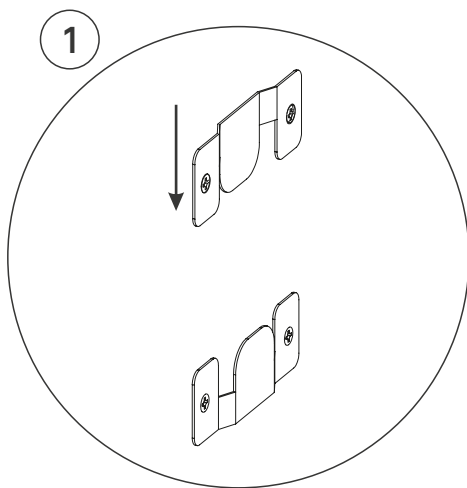

**3.**



901.551.09 (x3)

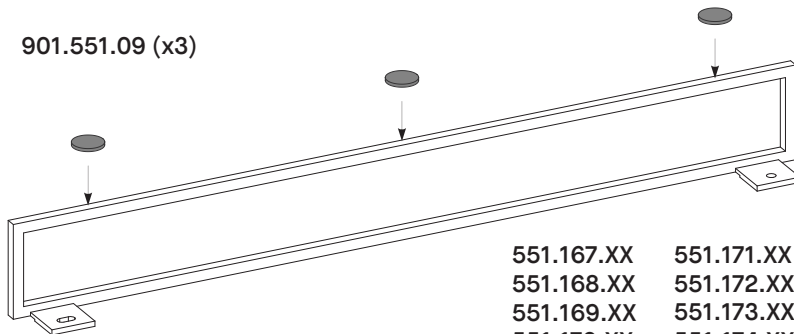

551.167.XX	551.171.XX
551.168.XX	551.172.XX
551.169.XX	551.173.XX
551.170.XX	551.174.XX

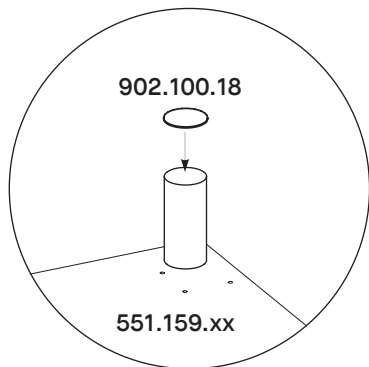

902.100.18

551.159.xx

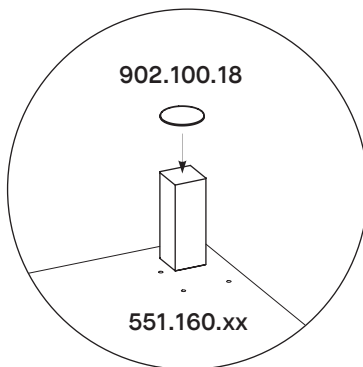

902.100.18

551.160.xx

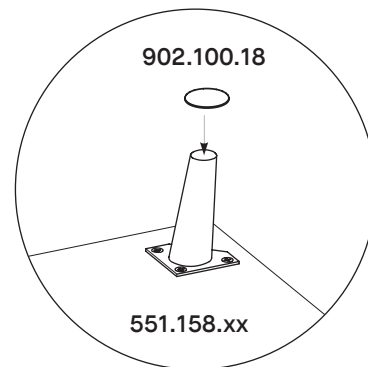

902.100.18

551.158.xx

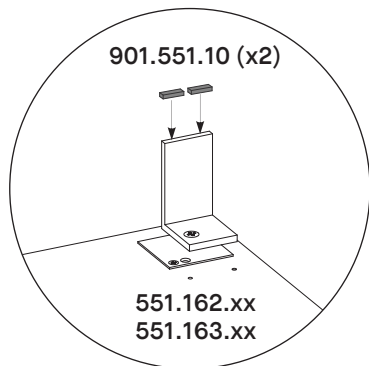

901.551.10 (x2)

551.162.xx  
551.163.xx

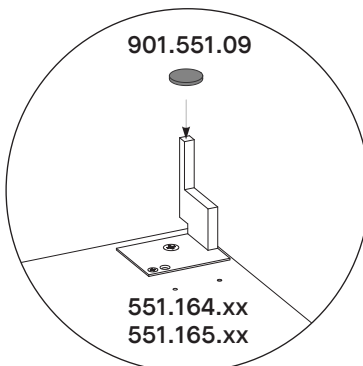

901.551.09

551.164.xx  
551.165.xx

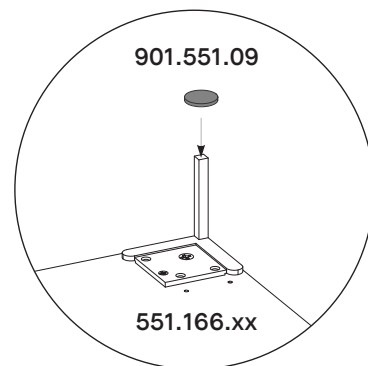

901.551.09

551.166.xx



p. 13 - 19

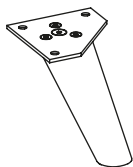

551.158.xx

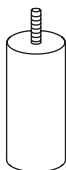

551.159.xx

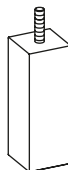

551.160.xx

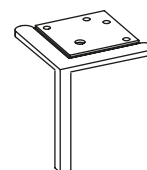

551.166.xx

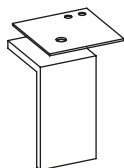

551.164.xx

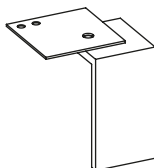

551.165.xx

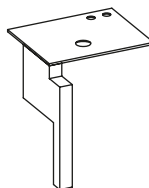

551.162.xx

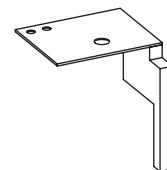

551.163.xx



p. 20 - 25

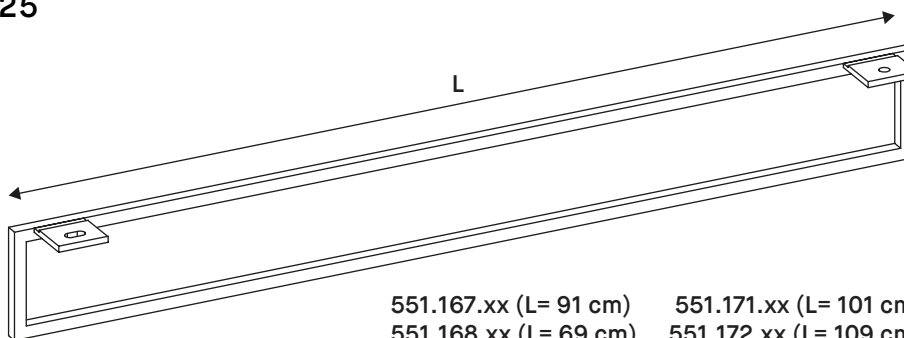

551.167.xx (L= 91 cm)

551.168.xx (L= 69 cm)

551.169.xx (L= 81 cm)

551.170.xx (L= 89 cm)

551.171.xx (L= 101 cm)

551.172.xx (L= 109 cm)

551.173.xx (L= 121 cm)

551.174.xx (L= 55 cm)

# 4.

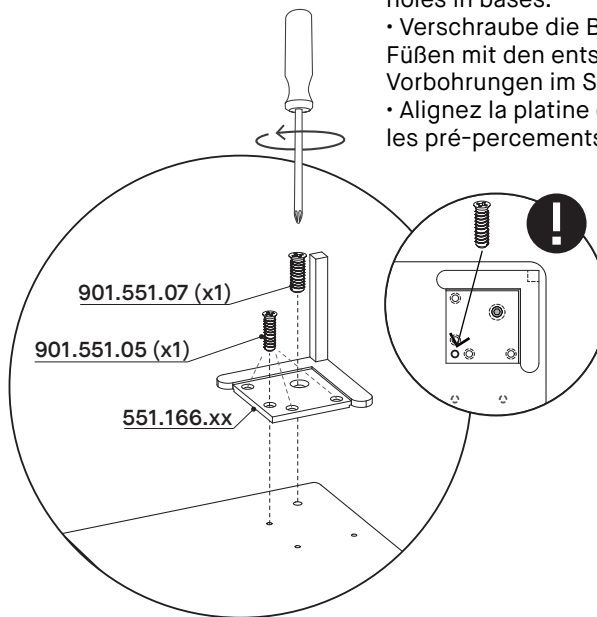
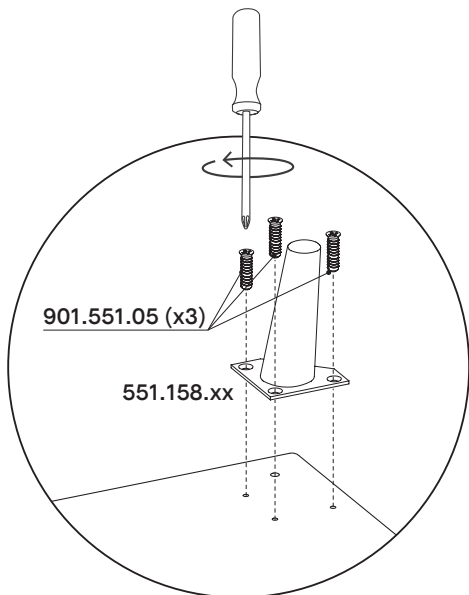
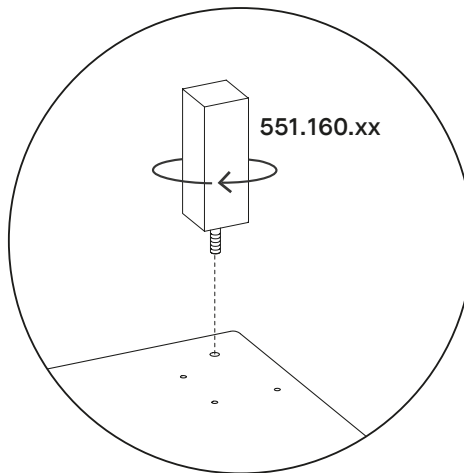
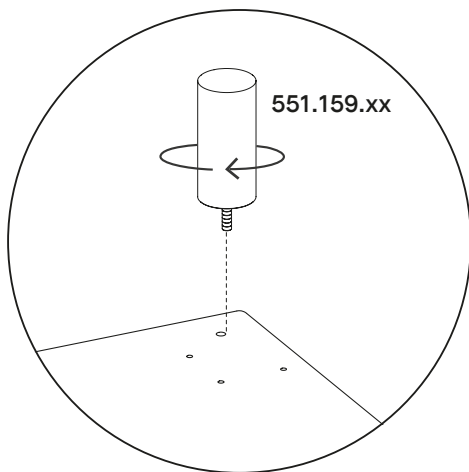

- Match holes of fixing plates to holes in bases.
- Verschraube die Bohrungen in den Füßen mit den entsprechenden Vorbohrungen im Sofamodul.
- Alignez la platine de fixation sur les pré-perçements de la base.

# 4.

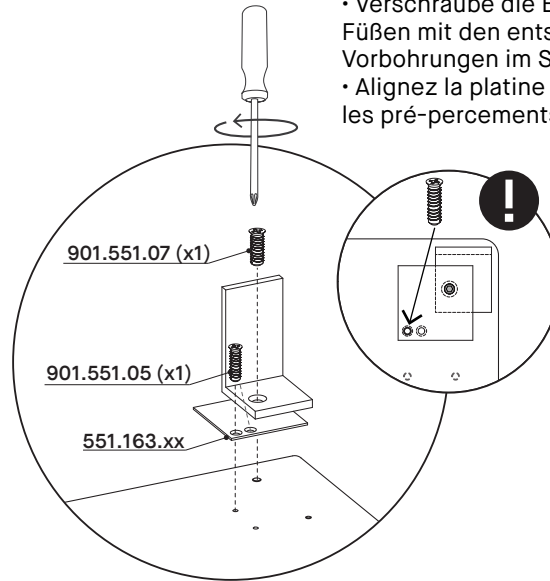
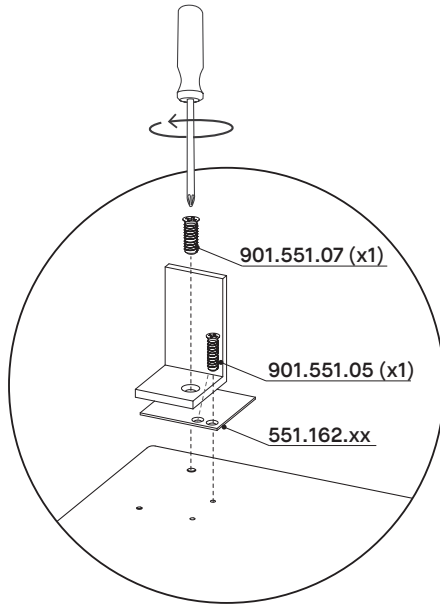

- Match holes of fixing plates to holes in bases.
- Verschraube die Bohrungen in den Füßen mit den entsprechenden Vorbohrungen im Sofamodul.
- Aligned la platine de fixation sur les pré-perçements de la base.

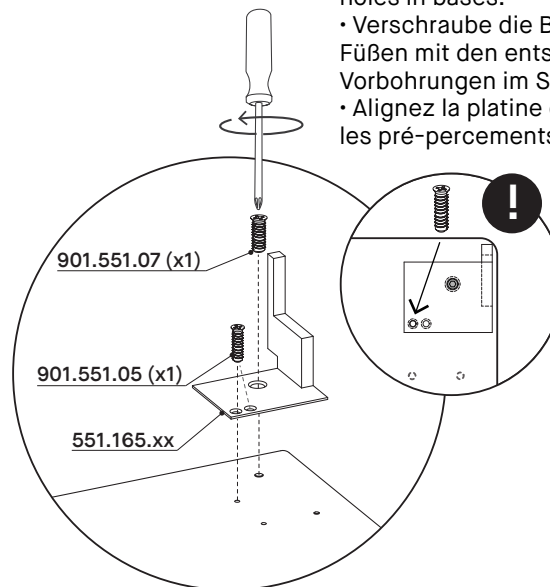
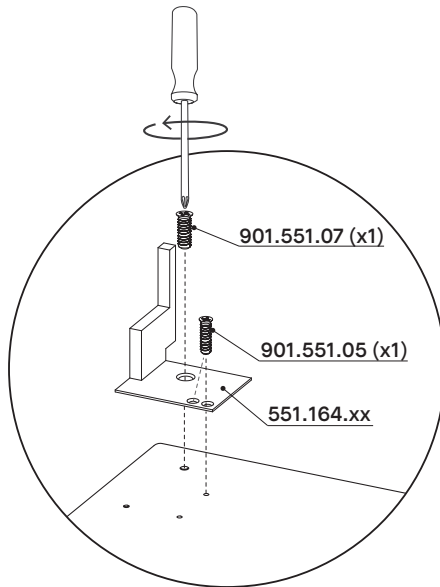

- Match holes of fixing plates to holes in bases.
- Verschraube die Bohrungen in den Füßen mit den entsprechenden Vorbohrungen im Sofamodul.
- Aligned la platine de fixation sur les pré-perçements de la base.

5.

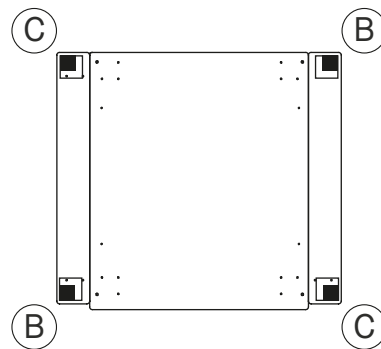
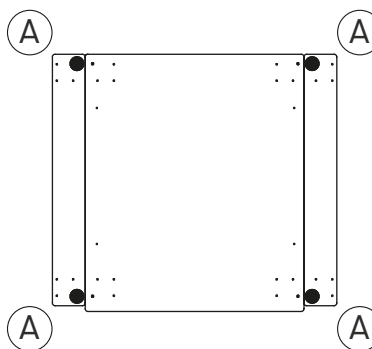
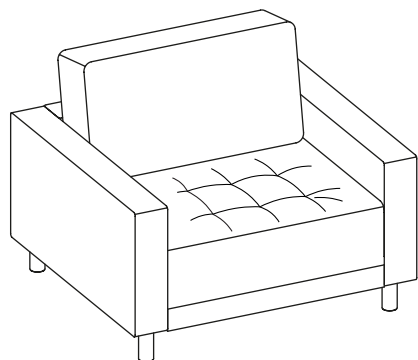
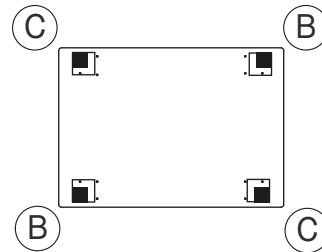
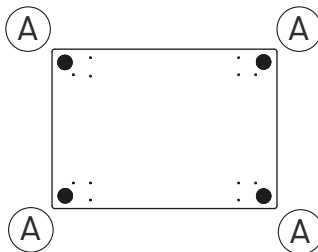
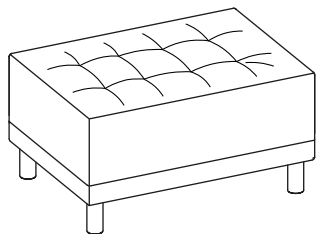

551.158.xx



551.159.xx

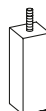

551.160.xx

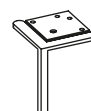

551.166.xx



B

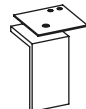

551.162.xx

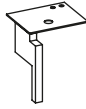

551.164.xx



C



551.163.xx



551.165.xx

# 6.

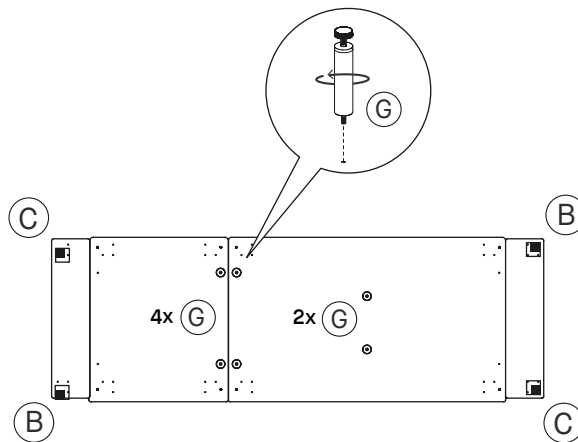
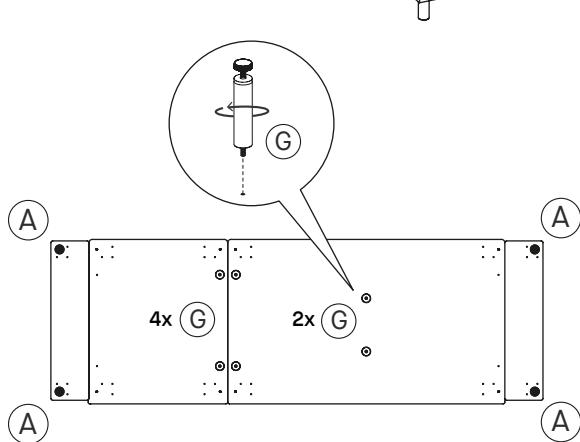
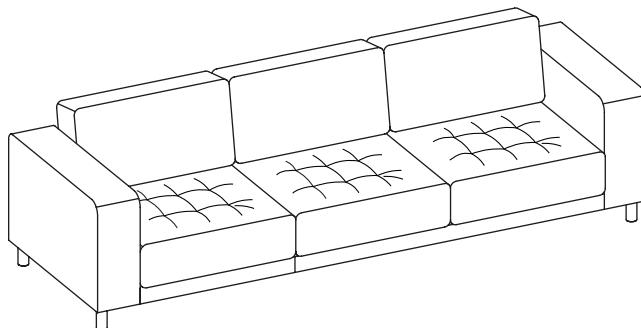

551.158.xx

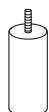

551.159.xx

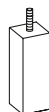

551.160.xx



551.166.xx



551.175.00

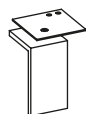

551.162.xx

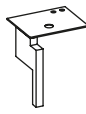

551.164.xx



551.163.xx

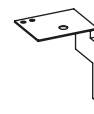

551.165.xx

# 7.

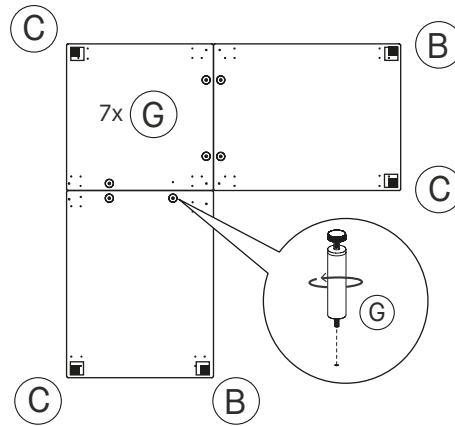
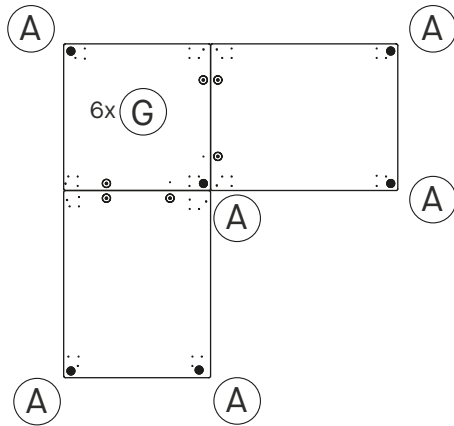
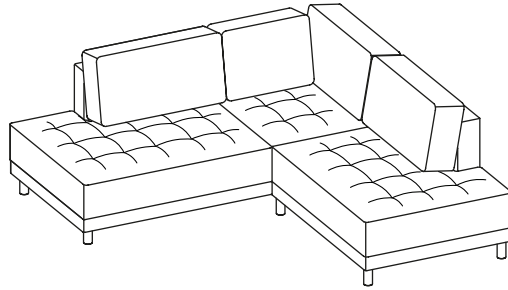

●  
A



551.158.xx



551.159.xx

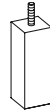

551.160.xx



551.166.xx

●  
E



551.175.00

■  
B

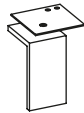

551.162.xx

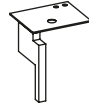

551.164.xx

■  
C

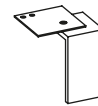

551.163.xx

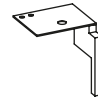

551.165.xx

8.

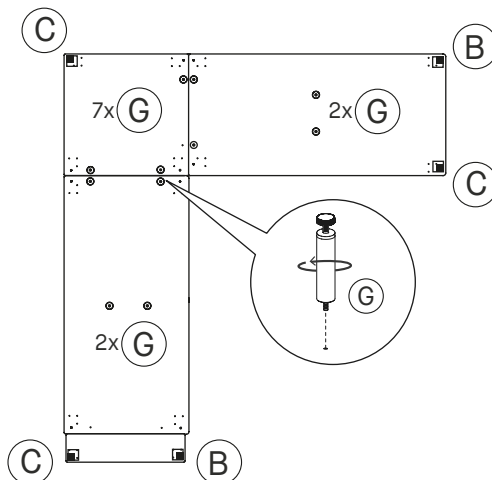
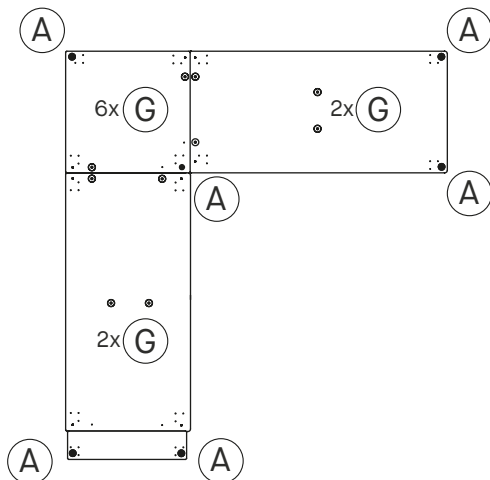
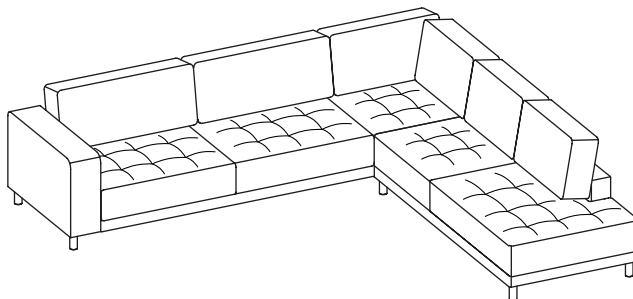

551.158.xx

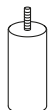

551.159.xx

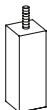

551.160.xx

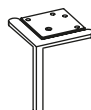

551.166.xx



551.175.00

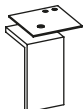

551.162.xx

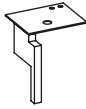

551.164.xx

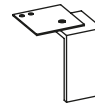

551.163.xx

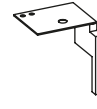

551.165.xx

9.

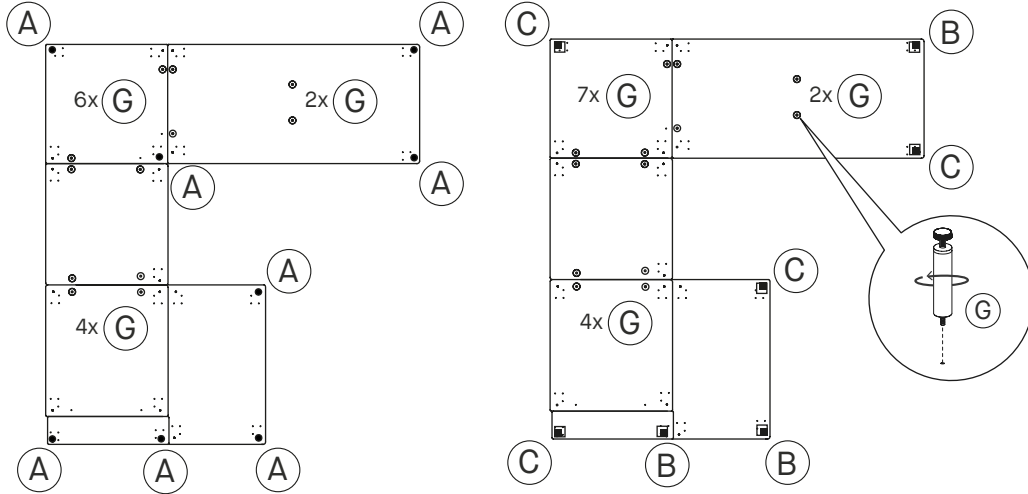
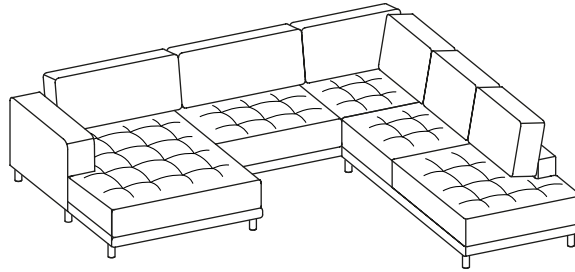

A



551.158.xx



551.159.xx

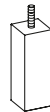

551.160.xx



551.166.xx

G



551.175.00

B



551.162.xx

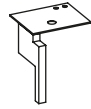

551.164.xx

C



551.163.xx

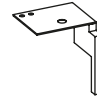

551.165.xx

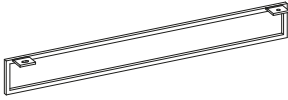
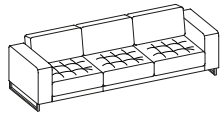
				
SKU	L	type	SKU	module
551.167.XX	91 cm	D	554.100.00	CL05 LYVYN Base, 80 cm
			554.101.00	CL05 LYVYN Base, 120 cm
			554.102.00	CL05 LYVYN Base, 160 cm
			554.103.00	CL05 LYVYN Base, 200 cm
			554.104.00	CL05 LYVYN Sofa-bed base, 200 cm
			554.104.01	CL05 LYVYN Sofa-bed base high, 200 cm
			554.105.00	CL05 LYVYN Extension, 72 cm
			554.106.00	CL05 LYVYN Extension, 84 cm
551.168.XX	69 cm	E	554.107.00	CL05 LYVYN Extension, 92 cm
551.169.XX	81 cm		554.108.00	CL05 LYVYN Extension, 104 cm
551.170.XX	89 cm		554.109.00	CL05 LYVYN Extension, 112 cm
551.171.XX	101 cm		554.110.00	CL05 LYVYN Extension, 124 cm
551.172.XX	109 cm		554.111.00	CL05 LYVYN Backrest, 80 cm
551.173.XX	121 cm		554.112.00	CL05 LYVYN Backrest, 120 cm
551.174.XX	57 cm	F	554.113.00	CL05 LYVYN Backrest, 160 cm
			554.114.00	CL05 LYVYN Backrest, 200 cm
			554.115.00	CL05 LYVYN Armrest left, 12 cm
			554.116.00	CL05 LYVYN Armrest right, 12 cm
			554.117.00	CL05 LYVYN Armrest left, 24 cm
			554.118.00	CL05 LYVYN Armrest right, 24 cm

# 4.

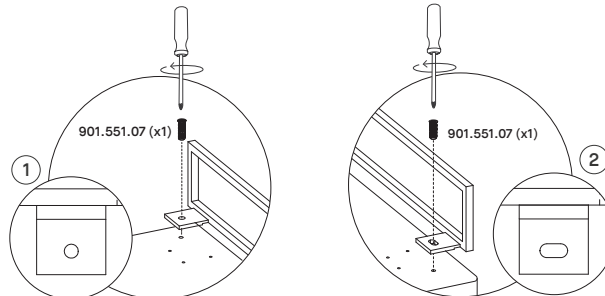

5.

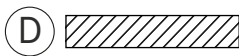
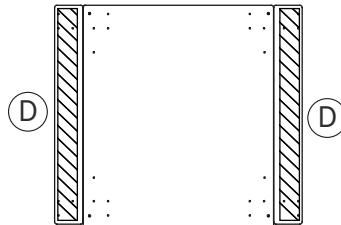
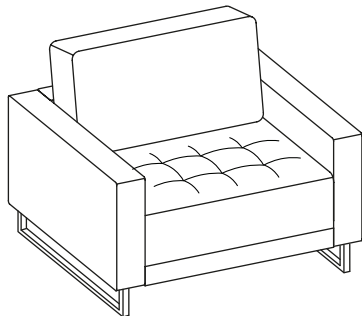
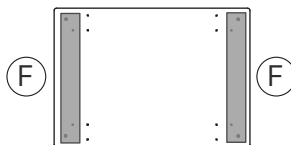
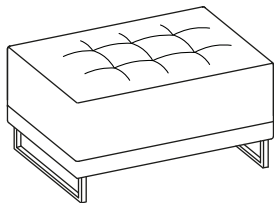

551.167.xx

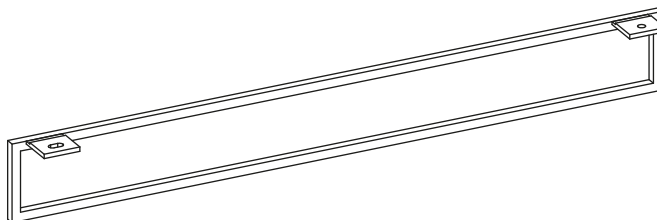

551.174.xx

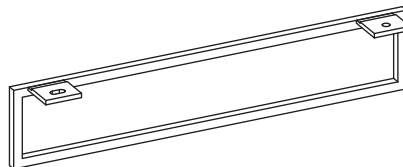

6.

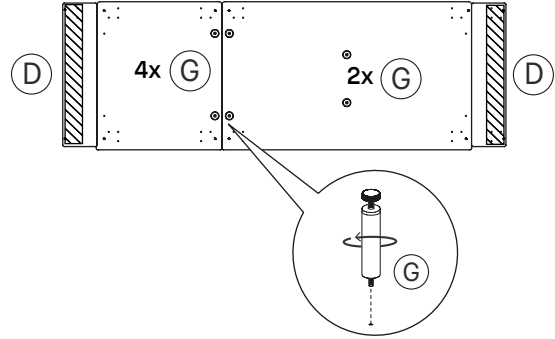
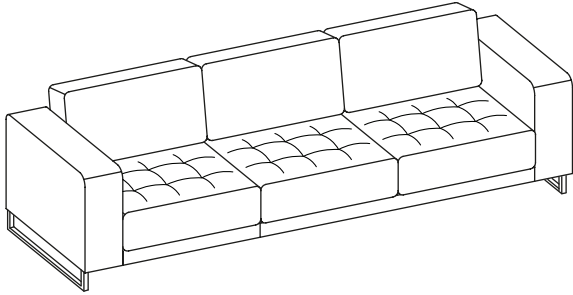

551.167.xx

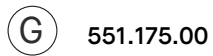
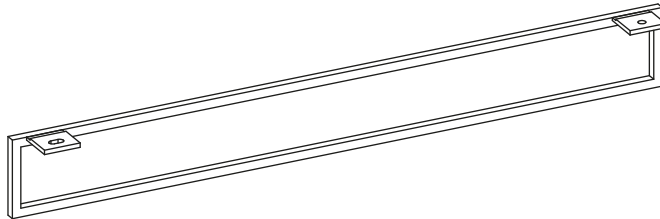

551.175.00



7.

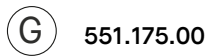
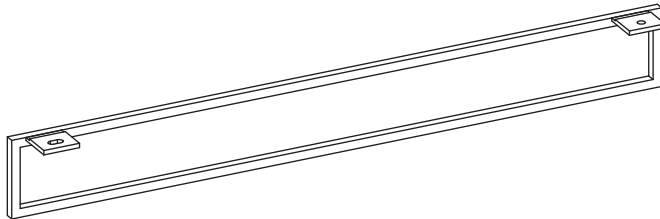
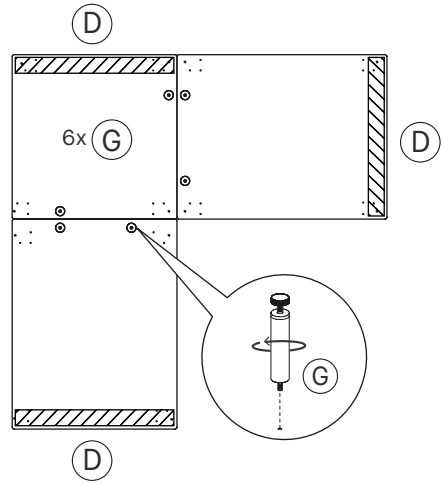
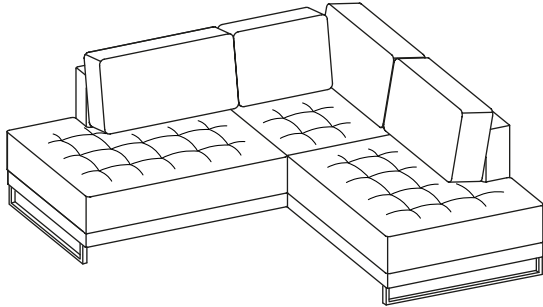

8.

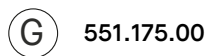
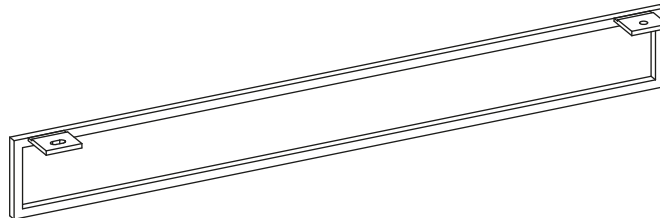
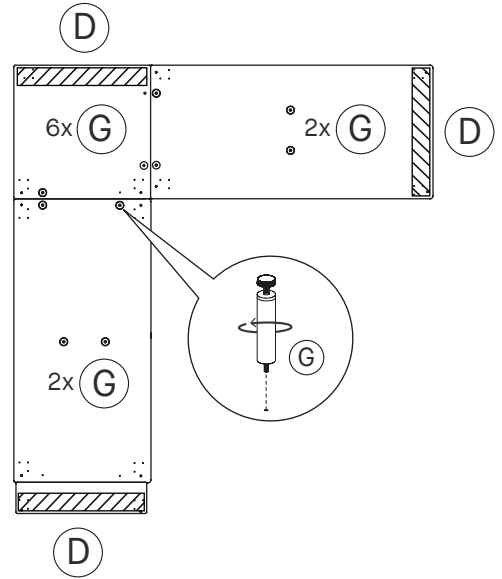
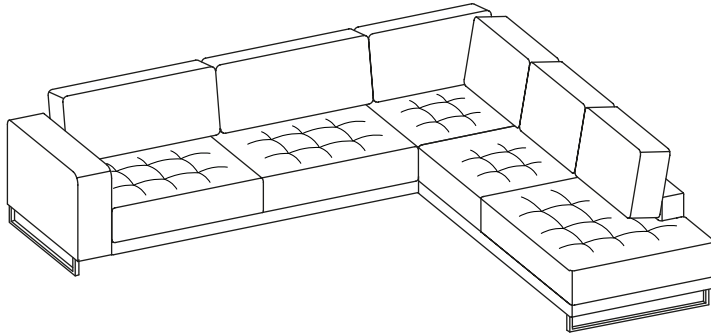

9.

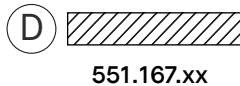
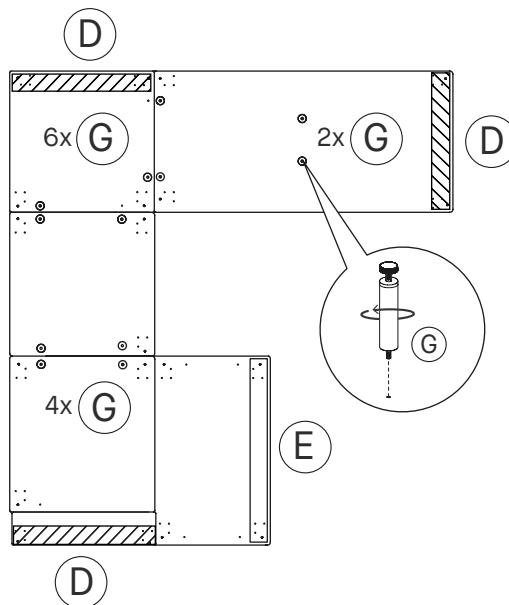
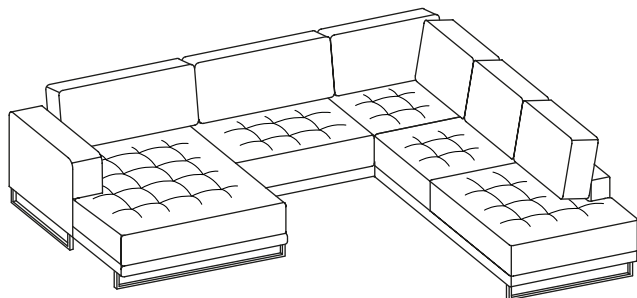

551.167.xx

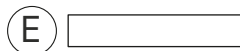
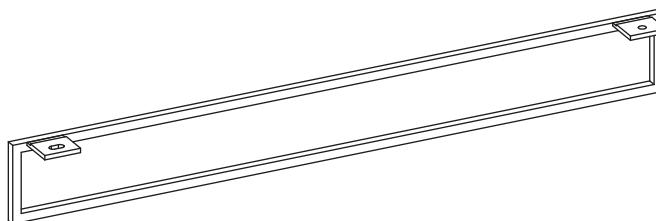

551.168.xx  
551.169.xx  
551.170.xx  
551.171.xx  
551.172.xx  
551.173.xx

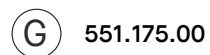
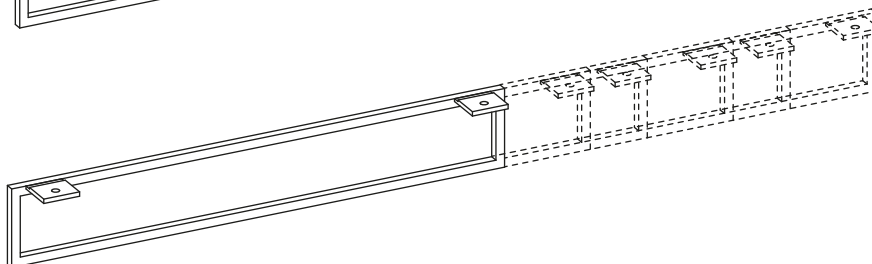

551.175.00



# 10.

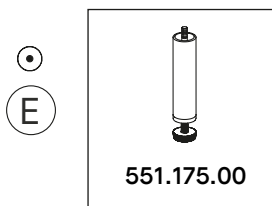
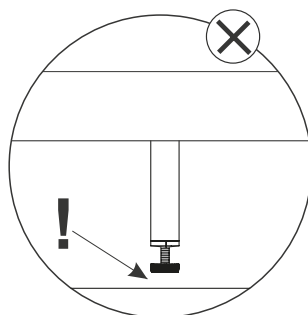
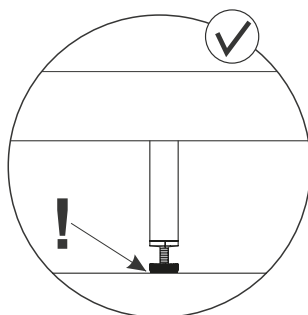
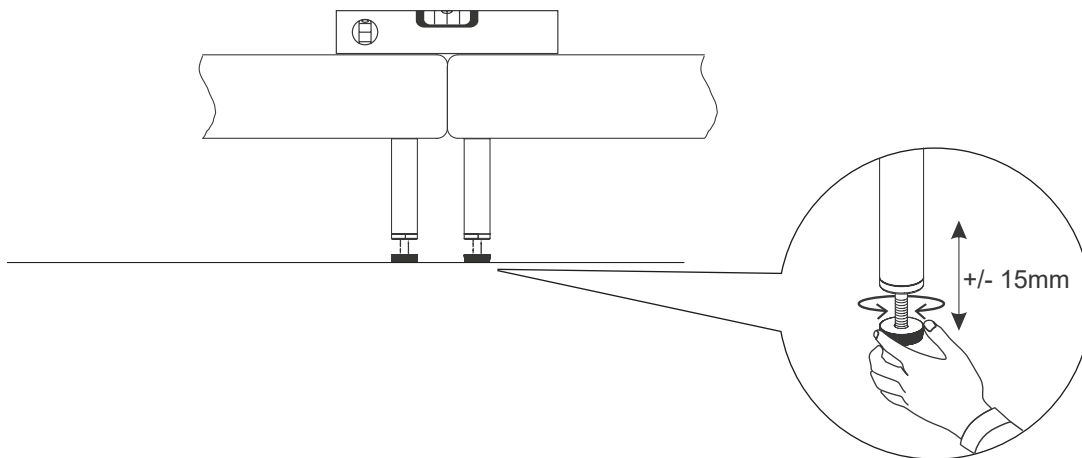

11.

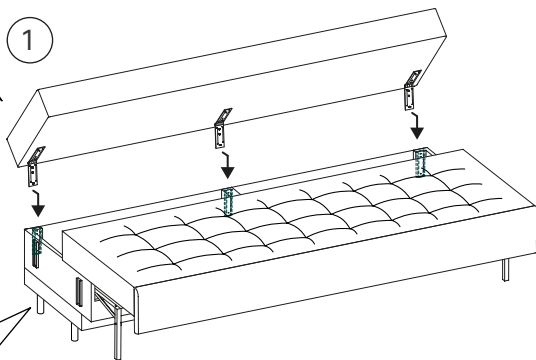
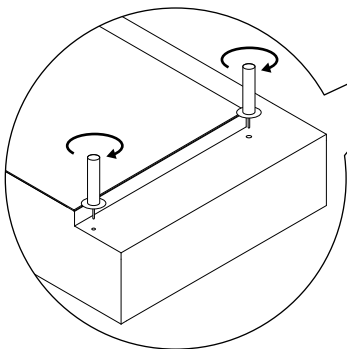
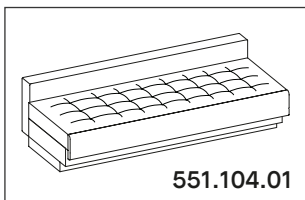
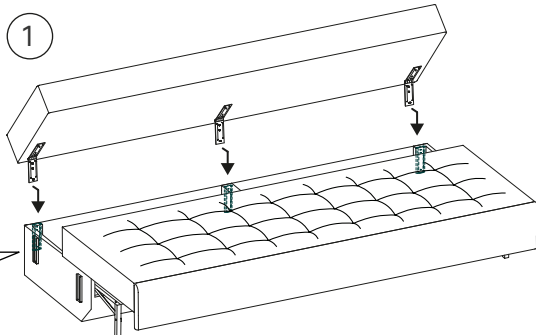
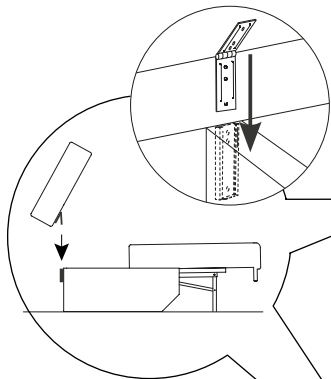
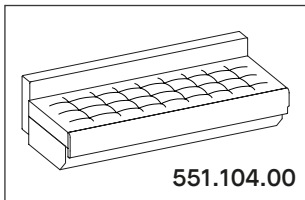

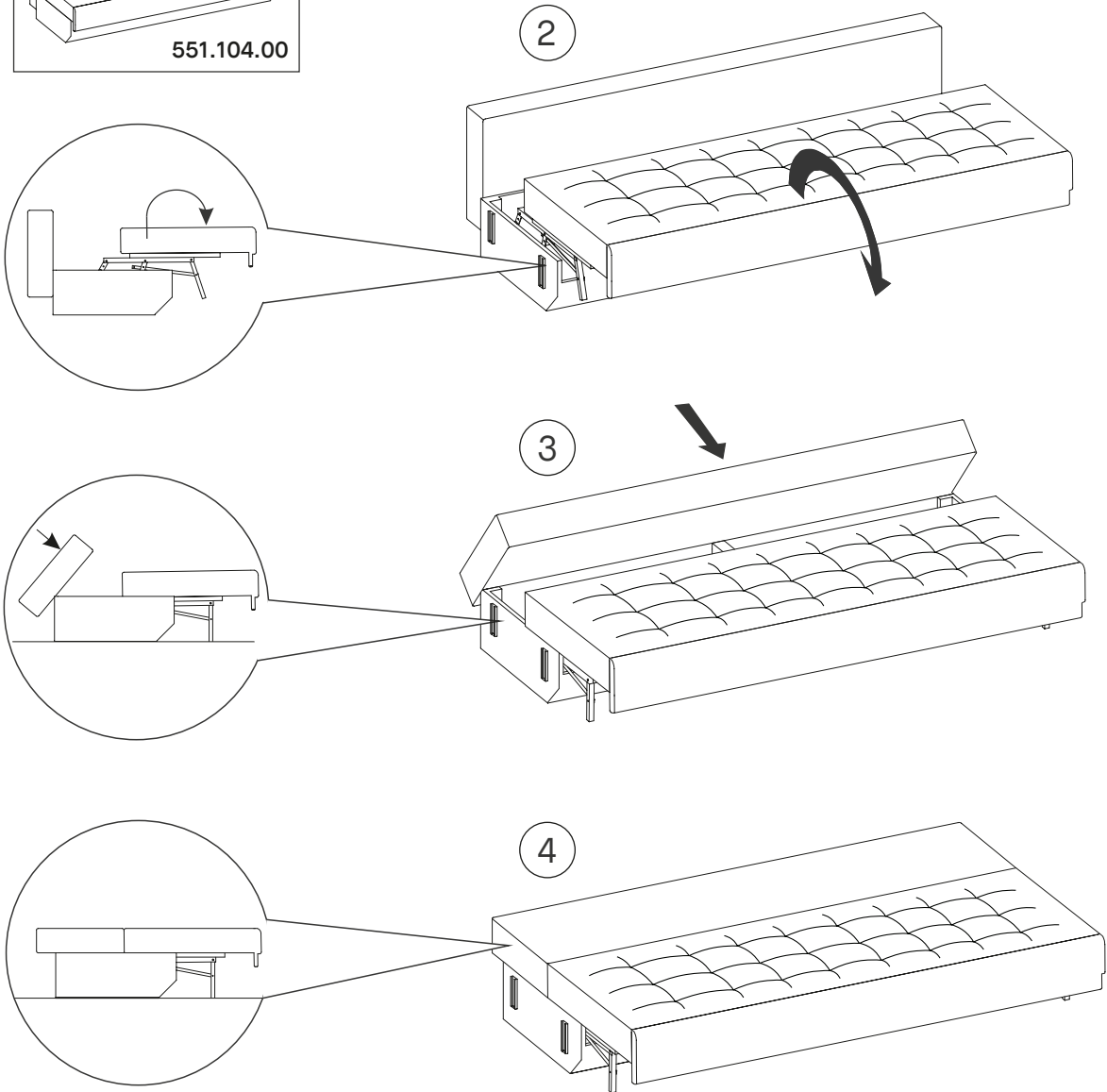
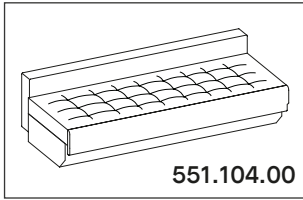

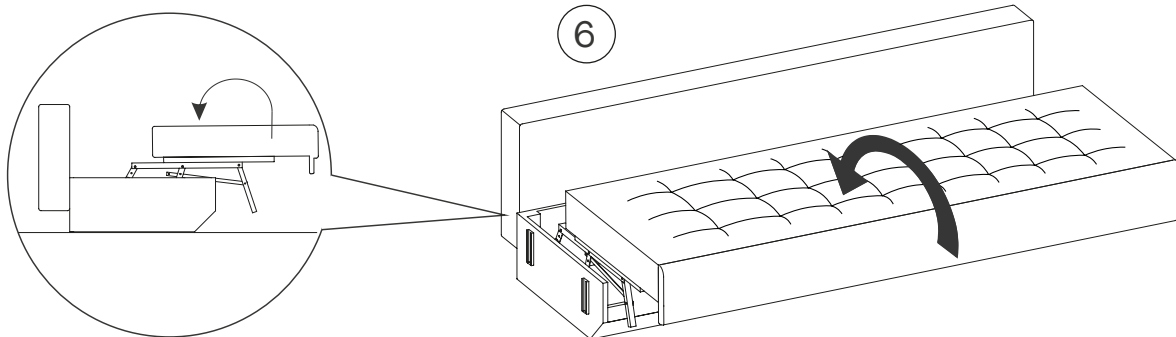
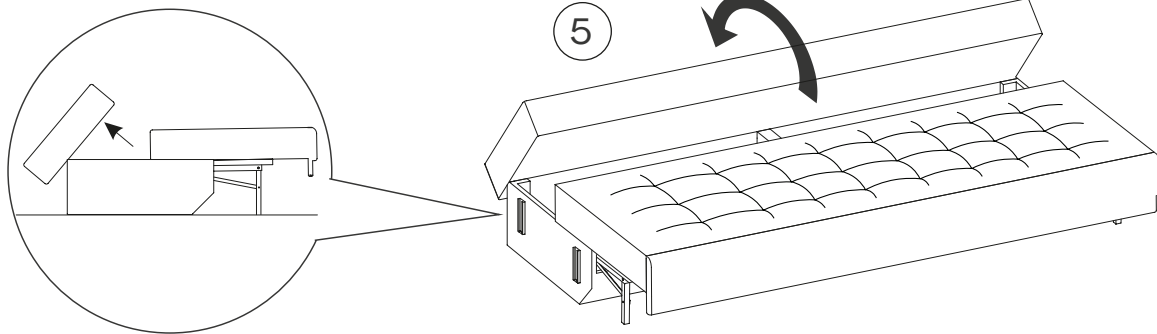

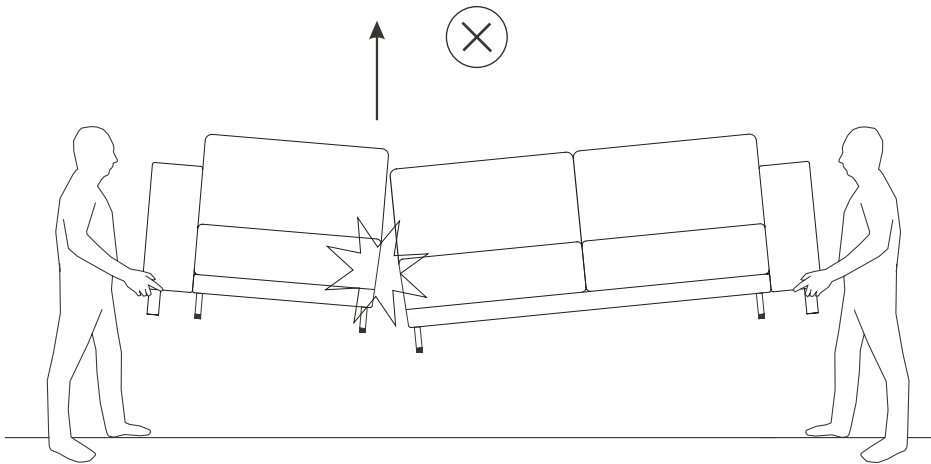
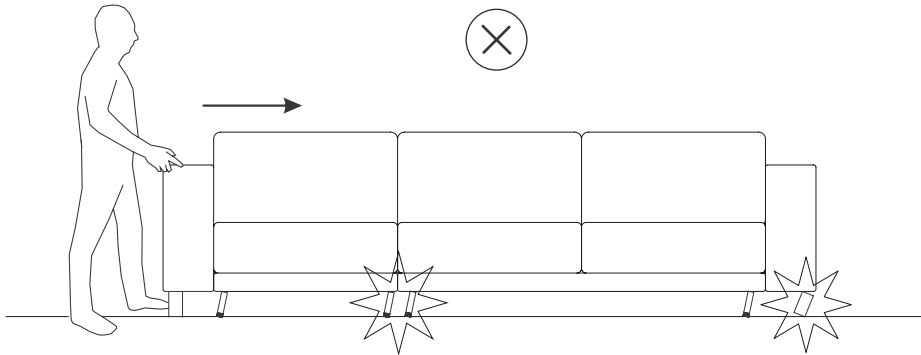

Mycs Sp. z o.o  
3A Zbożowa Street  
62-025 Kostrzyn  
Poland

E-Mail [support@mycs.com](mailto:support@mycs.com)

AT 0043 720 14 34 79  
CH 0041 223 55 01 39  
DE 0049 692 991 78 20 36  
FR 0033 176 21 61 95



[fb.com/mycscom](https://fb.com/mycscom)



[instagram.com/mycs\\_com](https://instagram.com/mycs_com)

FRAGEN?



QUESTIONS ?



MYCS

[www.mycs.com](http://www.mycs.com)