

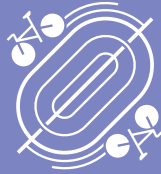

PARIS 2024



**TEAM LEADERS'
GUIDE**

CYCLING TRACK

5 to 11 August 2024

EN GAMES WIDE O
WIDE OPEN GAME
OUVRONS GRAND
RAND LES JEUX OUV
EN GAMES WIDE O
WIDE OPEN GAME
OUVRONS GRAND
RAND LES JEUX OUV
EN GAMES WIDE O
WIDE OPEN GAME
OUVRONS GRAND
RAND LES JEUX OUV
EN GAMES WIDE O



PARIS 2024

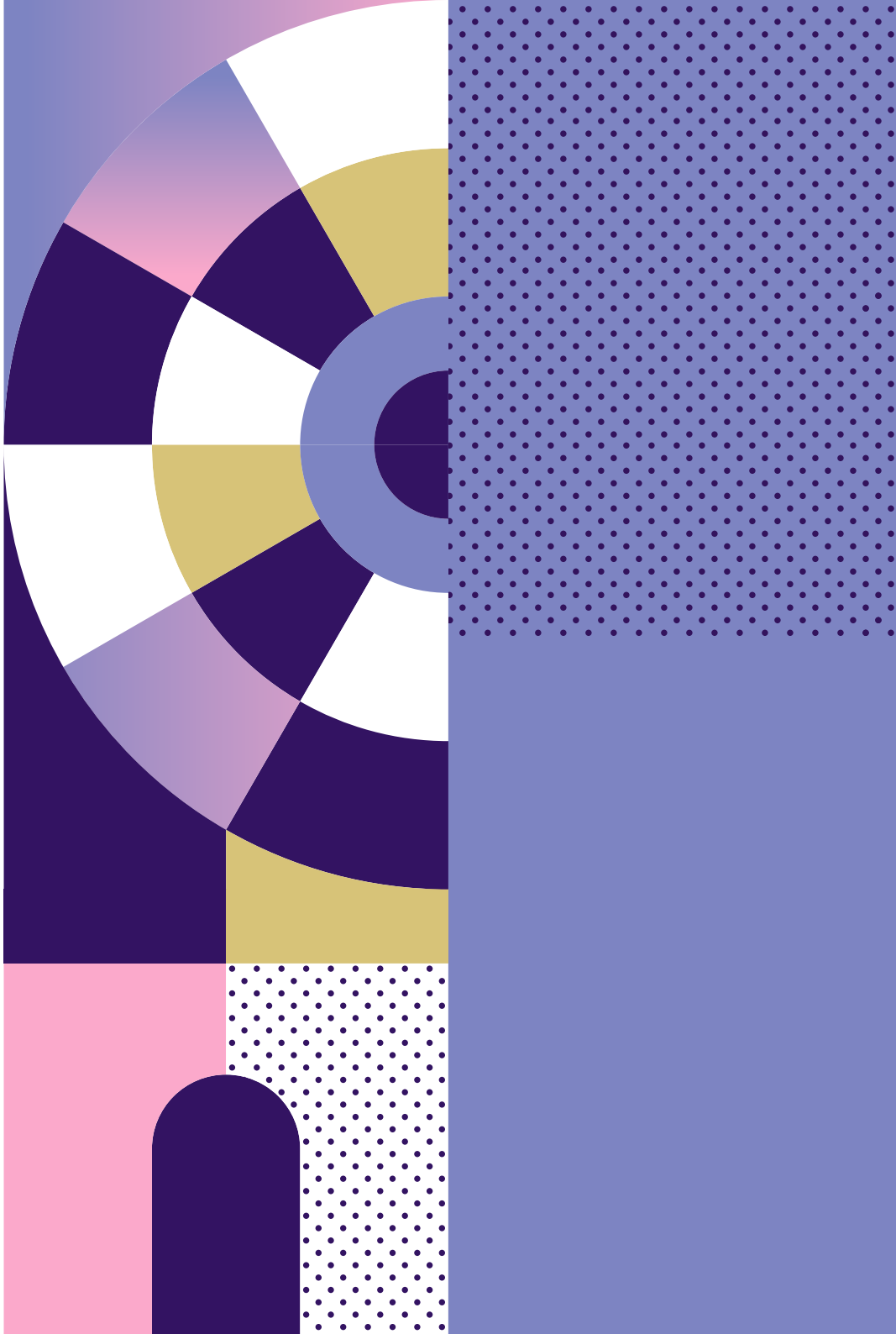



ABOUT THIS GUIDE

Published in June 2024, the series of Team Leaders' Guides offers a summary of competition-related material about each sport at Paris 2024 and provides a variety of information aimed at helping teams in their planning and final preparation for the Games.

All information provided in this Team Leaders' Guide was correct at the time of publication, but some details may change prior to the Games so NOC representatives are urged to regularly check the IOC's NOCnet and myInfo, as well as Paris 2024 website and application, for the latest updates or contact your respective Paris 2024 sport managers.

This information has been developed and approved by the IOC, International Federations and Paris 2024 competition management and may be updated as required leading up to the Games. The Team Leaders' Guides are designed for internal operational use by Paris 2024 stakeholders and should not be publicly shared.

WELCOME



On behalf of the Paris 2024 Organising Committee, I am delighted to present the series of Team Leaders' Guides for the Games of the XXXIII Olympiad.

At Paris 2024, we are proud to organise the first Games under the New Norm of the Olympic Agenda 2020, which focuses on economic, social and environmental efficiency and sets a precedent in the organisation of sports events. Our ambition is to present the first carbon-neutral Games, the first gender-balanced Games and the first Games open to all with the mass participation marathon. Paris 2024 aims to deliver responsible Games whether by using 95 percent of existing or temporary venues and 100 percent renewable energy during the Games, or by favouring a circular economy, sustainable food, and clean mobility, and by preserving the biodiversity on venues. By taking climate and environmental issues into account well before the event, we are breaking new ground in the history of the Games.

One hundred years since the last summer Games in France, Paris 2024 has huge ambitions for the Games in 2024. Our aim is to offer a new event model that is in tune with people's aspirations, especially those of the younger generations, for example by introducing four additional sports such as breaking, sport climbing, skateboarding or surfing.



Paris 2024 will be a spectacular celebration that takes sport into new and unexpected places: from the foot of the Eiffel Tower to the Champ-de-Mars, the Grand Palais, Invalides, Place de la Concorde, and the Château de Versailles. Beyond Paris and its region, the whole country will be the Games' playground. Surfers will master the iconic wave of Teahupo'o in Tahiti (French Polynesia), while shooting athletes will compete in a state-of-the-art facility in Châteauroux. The 27,000 spectators in the Pierre Mauroy stadium in Lille will cheer for the basketball and handball competitions, and football fans have a choice of seven exceptional stadiums across the country, including Marseille. The city will also be the spectacular backdrop for the sailing competitions.

As athletes are the heart of Paris 2024 Olympic Games, we are committed to offer them an exceptional experience, with unique competition venues in iconic sites of Paris and France, such as the foot of the Eiffel Tower, the Château de Versailles or Teahupo'o in Tahiti.

Paris 2024 will leave a positive and lasting impact on the lives of residents by making long-anticipated investments, especially in Seine-Saint-Denis, such as the Olympic Village and the Aquatics Centre. All the facilities that will be used by athletes and delegations during the Games are designed with their legacy in mind so that they can be repurposed as public facilities, housing and offices based on local needs.

We hope that this guide, produced in collaboration with IOC Sport and International Federations, will provide you with the information you need to prepare for your Games.

We are looking forward to welcoming you to the City of Lights in the summer of 2024 for what we hope will be revolutionary Games.

Aurélie Merle
Executive Sport Director

CONTENTS

1

CYCLING TRACK OVERVIEW	1
CYCLING TRACK COMPETITION	2
MEDAL EVENTS	2
COMPETITION MANAGEMENT	4
INTERNATIONAL TECHNICAL OFFICIALS (ITOS)	5
NATIONAL TECHNICAL OFFICIALS (NTOS)	6
RULES	7
LATE ATHLETE REPLACEMENT (LAR)	7
INDIVIDUAL EVENTS	7
TEAM EVENTS	8
CLOTHING & EQUIPMENT	9

2

COMPETITION	11
COMPETITION SCHEDULE	12
COMPETITION FORMAT	18
TEAM SPRINT	18
SPRINT	19
KEIRIN	20
TEAM PURSUIT	21
OMNIUM	22
MADISON	23
PRE-COMPETITION PROCEDURES	23
RIDER CONFIRMATION AND LICENCE CONTROL	23
ATHLETES' HEADSHOTS	24
TEAM MANAGER MEETING	24
RIDER NUMBER AND TRANSPONDER DISTRIBUTION	25
RACE NUMBERS	25
WATER BOTTLES	25

COMPETITION PROCEDURES	25
WARM-UP.....	25
BIKE CHECK PROCEDURE.....	26
ON-BOARD CAMERAS.....	26
ATHLETES' ACCESS TO THE TRACK.....	27
ACCESS RAMP AND LANDINGS.....	27
ACCREDITED AND TEAM SEATING.....	28
POST COMPETITION PROCEDURES	28
ATHLETES' EXIT OF THE TRACK.....	28
MIXED ZONE.....	28

3

COMPETITION VENUE	29
SAINT-QUENTIN-EN-YVELINES NATIONAL VELODROME	30
VENUE ACCESS.....	30
VENUE MAP.....	35
FIELD OF PLAY (FOP).....	35
VENUE FACILITIES & SERVICES.....	35
VENUE ACCREDITATION HELP OFFICE (VAHO).....	41

4

TRAINING	43
TRAINING VENUE	44
TRAINING SESSIONS	44
TRAINING REGULATIONS	45
TRAINING FACILITIES	45
VENUE ACCESS	45
VENUE TRANSPORT ACCESS.....	45
DEDICATED TRAINING VENUE ACCESS.....	45

5

CYCLING TRACK APPENDIX	47
1 - ATHLETES' SPORT EQUIPMENT DROP-OFF	48
SCENARIO 1	49
SCENARIO 2	51
SCENARIO 3	52
2 - ATHLETES' SPORT EQUIPMENT PICK-UP	53
WHAT TO DO IN ADVANCE?	53
HOW IS IT GOING TO WORK?	54
3 - VEHICLE ACCESS PARKING PERMIT – VAPPS	55
4 - VIDEO ANALYST PLATFORM	56
5 - LINK FOR BOOKINGS SYSTEM, VAPPS REQUEST AND QR CODE	56
6 - MDS GUIDELINES EXTRACT	57

6

GENERAL INFORMATION	60
THE OLYMPIC GAMES: ESSENTIALS	61
PARIS AND FRANCE IN 2024	61
THE 2024 OLYMPIC GAMES IN BRIEF	62
ACCREDITATION	63
OLYMPIC IDENTITY AND ACCREDITATION CARD (OIAC)	63
ACCREDITATION CATEGORIES AND PRIVILEGES	64
ANTI-DOPING	69
ANTI-DOPING PROGRAMME	69
OPERATIONS DURING THE GAMES	70
TRANSPORTATION AFTER COMPLETING DOPING CONTROL ON THE DAY OF THE CLOSING CEREMONY	70
ARRIVALS AND DEPARTURES	71
PRIMARY PORTS OF ENTRY (PPOE)	71
SECONDARY PORTS OF ENTRY (SPOE)	71
ACTIVATION PERIOD	72
ARRIVALS & DEPARTURES SERVICE	73
BAGGAGE AND ATHLETES' OVERSIZED SPORT EQUIPMENT	74
CEREMONIES	75
OPENING CEREMONY	75
CLOSING CEREMONY	78
VICTORY CEREMONIES	80

CHAMPIONS PARK	81
ATHLETE TRANSPORTATION SERVICES	82
SCHEDULE OF CELEBRATIONS	82
CHAMPIONS PARK INFORMATION DESK	82
ENVIRONMENTAL RESPONSIBILITY	83
RECOMMENDATIONS	84
MEDICAL SERVICES	85
OLYMPIC VILLAGE POLYCLINIC	85
MEDICAL SERVICES AT SATELLITE OLYMPIC VILLAGES	86
DESIGNATED GAMES HOSPITALS	88
OLYMPIC VIDEO PLAYER (OVP)	88
OLYMPIC VILLAGES AND ACCOMMODATION	89
OLYMPIC VILLAGES DATES OF OPERATION	89
SECURITY	90
SECURITY AT VENUES	90
SECURITY OF TRANSFER AND TRANSPORT OPERATIONS	92
PROHIBITED OR RESTRICTED ITEMS POLICY	92
OBJECTS CONSIDERED AS “TOOLS OF THE TRADE”	94
EMERGENCY SERVICES	95
SPORT INFORMATION CENTRE	96
MYINFO	97
TECHNICAL FILMING AT VENUES	98
TECHNOLOGY	98
TICKETING AND ACCREDITED SEATING	99
GAMES-TIME TICKET SALES	99
COMPLIMENTARY SPORT TICKETS	99
TRANSPORT	100
TA TRAINING AND COMPETITION SERVICES	101
OLYMPIC ROUTE NETWORK (ORN)	103
INTERCITY TRAVEL	103
PUBLIC TRANSPORT	103
TRANSPORT CONNECT (TC)	104
TRANSPORT DESK	105
TRANSPORT APP	105
ATHLETES’ BAGGAGE AND OVERSIZED SPORT EQUIPMENT	106
SPORT EQUIPMENT INTER-VENUE TRANSPORT	106

7

APPENDICES	109
VENUE MAP	110
VENUE MAP	111
OLYMPIC VILLAGE	112
COMPETITION SCHEDULE	113
OLYMPIC COMPETITION VENUES	116
OLYMPIC TRAINING VENUES	117

1

**CYCLING
TRACK
OVERVIEW**

CYCLING TRACK COMPETITION

The Cycling Track competition at the Paris 2024 Olympic Games will be held from Monday 5 August to Sunday 11 August 2024 at the Saint-Quentin-en-Yvelines National Velodrome, in Montigny-le-Bretonneux. The competition will consist of 12 medal events, summarised below:

MEDAL EVENTS

Total number of medal events: 12

MEN (6)

- Team Sprint
- Sprint
- Keirin
- Team Pursuit
- Omnium
- Madison

WOMEN (6)

- Team Sprint
- Sprint
- Keirin
- Team Pursuit
- Omnium
- Madison

A total of 190 athletes, 95 men and 95 women, will take part in the Cycling Track competition. For details of the qualification system, see the [IOC website](#).





KEY DATES

1 June 2024	Opening of the Sport Entries system (SEQ)
8 July 2024	Closing of the Sport Entries system (23:59 Central European Summer Time)
18 July 2024	Opening of the Olympic Village
26 July 2024	Opening Ceremony
31 July to 4 August 2024	Training
4 August 2024	Team manager meeting (17:00 – 18:00)
5 to 11 August 2024	Competition
11 August 2024	Closing Ceremony
13 August 2024	Closing of the Olympic Village

COMPETITION MANAGEMENT

UNION CYCLISTE INTERNATIONALE (UCI)

- **UCI Sports Director:** Peter VAN DEN ABEELE (BEL)
- **UCI Head of Major Events and Olympic Games:** Kevin MACCUISH (CAN)
- **UCI Major Events Delivery Manager:** Kevin BENJAMIN (USA)
- **International Federation Technical Delegate:** Jessika GRAND BOIS (CAN)

PARIS 2024 COMPETITION MANAGEMENT

- **Cycling and Para Cycling Manager:** Anne LE PAGE
- **Cycling Track Discipline Manager:** Beatriz Akemi DE REZENDE
- **Cycling Track Technical Operations Manager:** Aude LEFORT
- **Cycling Track Field of Play Coordinator:** Mélanie COMBES
- **Cycling and Para Cycling Sport Services Coordinator:** Charlotte TESSIER
- **Cycling and Para Cycling Administrative Coordinator:** Elise PICARD
- **Cycling and Para Cycling Services Assistant:** Svetlana LOIZEAU
- **Cycling Track Sport Equipment Coordinator:** Romain POURRAT
- **Cycling Track Sport Services Coordinator:** Louise ROSE
- **Cycling Track IF Services Coordinator:** Sonia ALMEIDA
- **Cycling Track Technical Officials Services Coordinator:** Juliette ROBERT
- **Cycling Track Athlete Services Coordinator:** Laetitia MONZO
- **Cycling Track Sport Information Coordinator:** Kenou WU
- **Cycling Track Workforce Coordinator:** Lucile QUENIN

Paris 2024 volunteers will support event operations.





INTERNATIONAL TECHNICAL OFFICIALS (ITOS)

President of the Commissaires' Panel (PCP)	Randall SHAFER	USA
Starter (STA)	Adrien LEVESQUE	CAN
Secretary (SEC)	Karen O'CALLAGHAN	AUS
Judge – Referee	Philip POLLARD	GBR
Members	Morgane GARNIER	FRA
	Andreas GENSHEIMER	GER
	Marzena MROWCZYNSKA	POL
	Chi Yu WONG	HKG

NATIONAL TECHNICAL OFFICIALS (NTOS)

National Commissaires	Magali BARBE	FRA
	Jérôme BIHOUEE	FRA
	Julien COUTANT	FRA
	Marie-Laure LEVITE	FRA
	Jean-François MAILLET	FRA
	Grégory MAURI	FRA
	Camille MEUNIER	FRA
	Alison RASSET	FRA
	Mickael ROUZIERE	FRA
	Cyrielle SERVAT	FRA
	Didier TIFFON	FRA
	Guillaume VERGER	FRA
	Elise WHEELER	FRA





RULES

All Cycling competitions will be held in accordance with the editions of the following documents that are in force at the time of the Games.

→ **UCI Constitution and Regulations** available on the website

<https://www.uci.org/>

→ **IOC Olympic Charter** available on the website

<https://olympics.com/ioc/olympic-charter>.

In accordance with Rule 46 of the IOC Olympic Charter, the UCI will be responsible for the control and direction of the Cycling competitions at the Paris 2024 Olympic Games.

LATE ATHLETE REPLACEMENT (LAR)

INDIVIDUAL EVENTS

Late Athlete Replacement (LAR) will be allowed up until two (2) hours prior to the Riders' Confirmation Meeting. Any athlete for which an accreditation application has been submitted by the accreditation deadline may be used as replacement provided that he/she is eligible. After this date and time, only "Ap" alternate athletes may be used as replacement athletes. In Cycling Track each qualified team in Team Sprint and each qualified team in Team Pursuit or Madison is entitled to one (1) "Ap" athlete. The final deadline for substitution of an athlete using an "Ap" alternate athlete is the time of the confirmation of the team composition (the approval process must be completed by the confirmation of the team composition, and it may take up to eight [8] hours).

Please note that LAR can also be applied for a NOCs "Ap" athlete up until the Technical Meeting in case of injury, ADRV or exceptional circumstances. Any athlete for which an accreditation application has been submitted by the accreditation deadline may be used as an "Ap" replacement provided that he/she is eligible and qualified in accordance with the Qualification System.

For more detailed and up-to-date information on Athlete Replacement Procedures, please refer to the latest version of the IOC LAR Policy and the Late Athlete Replacement Sport-Specific Procedures. If you do not have direct access to these documents, please contact your NOC to request a copy.

TEAM EVENTS

LAR will be allowed up until two (2) hours prior to the Riders' Confirmation Meeting. Any athlete for which an accreditation application has been submitted by the accreditation deadline may be used as replacement provided that he/she is eligible. After this date and time, only Ap alternate athletes may be used as replacement athletes. In Cycling Track each qualified team in Team Sprint and each qualified team in Team Pursuit or Madison is entitled to one (1) Ap athlete. The final deadline for substitution of an athlete using an Ap alternate athlete is the time of the confirmation of the team composition (the approval process must be completed by the confirmation of the team composition, and it may take up to eight [8] hours).

The Ap athlete, once activated, becomes an Aa and can compete in the individual events (as long as the Ap was activated for the Team Pursuit, Team Sprint or Madison).

For more detailed and up-to-date information on Athlete Replacement Procedures, please refer to the latest version of the IOC LAR Policy and the Late Athlete Replacement Sport-Specific Procedures. If you do not have direct access to these documents, please contact your NOC to request a copy.





CLOTHING & EQUIPMENT

Clothing, bikes and equipment used by riders and other participants in the Olympic Games Paris 2024 Cycling Track competition must comply with the following documents:

- **UCI Constitution and Regulations** (available on the website)
<https://www.uci.org/regulations/3MyLDDrwJCJJ0BGGOFzOat>
 - Part I – General Organisation of Cycling as a Sport
 - Part III: Track Races
 - Part XI: Olympic Games
- **IOC Olympic Charter** (available on the website)
<https://olympics.com/ioc/olympic-charter>,
particularly *Rule 50: Advertising, Demonstrations, Propaganda*)
- IOC Guidelines Regarding Authorised Identifications for the Games of the XXXIII Olympiad, Paris 2024 **for Cycling Track:**
<https://stillmed.olympics.com/media/Documents/Olympic-Games/Paris-2024/UCI.pdf>

The prohibition of any advertising and publicity in and above Olympic sites (as expressed in the Olympic Charter) is one of the aspects that differentiate the Olympic Games from other international events. This principle is reflected in the Bye-law to Rule 50 of the Olympic Charter. Detailed information on the implementation of Rule 50 to clothing, equipment, accessories and other items is detailed in the IOC's Guidelines Regarding Authorised Identifications for the Games of the XXXIII Olympiad, Paris 2024, which has been distributed by the IOC to all NOCs, IFs and sporting goods manufacturers.

Please refer to the complete [Guidelines Regarding Authorised Identifications](#) document for detailed information and instruction on all aspects of Rule 50 and its application and enforcement at the Paris 2024 Olympic Games.

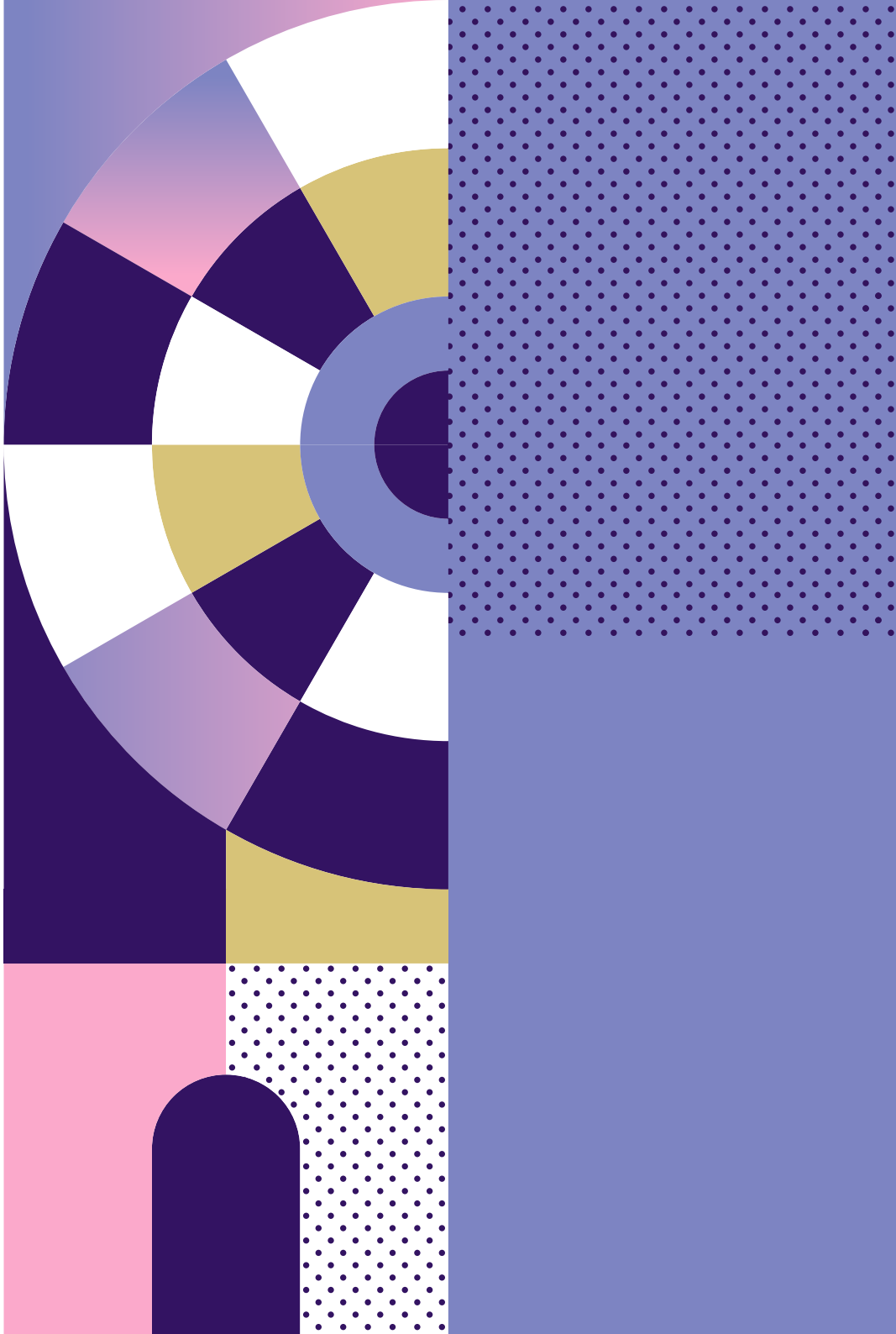

123

COMPETITION

COMPETITION SCHEDULE

SESSION	TIME	DURATION	EVENT
Monday 5 August 2024 – Saint-Quentin-en-Yvelines National Velodrome			
CTR01	17:00 – 20 :20	3 :20	Women’s Team Sprint Qualifying
			Men’s Team Pursuit Qualifying
			Women’s Team Sprint First Round
			Men’s Team Sprint Qualifying
			Women’s Team Sprint Finals
			Women’s Team Sprint Victory Ceremony
Tuesday 6 August 2024 – Saint-Quentin-en-Yvelines National Velodrome			
CTR02	17:30 – 20 :30	3 :00	Women’s Team Pursuit Qualifying
			Men’s Team Sprint First Round
			Men’s Team Pursuit First Round
			Men’s Team Sprint Finals
			Men’s Team Sprint Victory Ceremony
Wednesday 7 August 2024 – Saint-Quentin-en-Yvelines National Velodrome			





SESSION	TIME	DURATION	EVENT
CTR03	12:45 – 15:45	3 :00	Men's Sprint Qualifying
			Women's Keirin First Round
			Women's Team Pursuit First Round
			Men's Sprint 1/32 Finals
			Women's Keirin Repechages
			Men's Sprint 1/32 Finals Repechages
CTR04	17:30 – 20 :25	2:55	Men's Sprint 1/16 Finals
			Men's Team Pursuit Finals
			Men's Sprint 1/16 Finals Repechages
			Women's Team Pursuit Finals
			Men's Sprint 1/8 Finals
			Men's Team Pursuit Victory Ceremony
			Women's Team Pursuit Victory Ceremony
			Men's Sprint 1/8 Finals Repechages
Thursday 8 August 2024 – Saint-Quentin-en-Yvelines National Velodrome			

SESSION	TIME	DURATION	EVENT
CTR05	17:00 – 20 :25	3 :25	Men's Omnium Scratch Race 1/4
			Women's Keirin Quarterfinals
			Men's Omnium Tempo Race 2/4
			Men's Sprint Quarterfinals – Race 1
			Women's Keirin Semifinals
			Men's Omnium Elimination Race 3/4
			Men's Sprint Quarterfinals – Race 2
			Women's Keirin Final for places 7th – 12th
			Women's Keirin Final for Gold
			Men's Sprint Quarterfinals – Decider
			Men's Omnium Points Race 4/4
			Men's Sprint Final for places 5 th -8 th
			Women's Keirin Victory Ceremony
			Men's Omnium Victory Ceremony
Friday 9 August 2024 – Saint-Quentin-en-Yvelines			
National Velodrome			



SESSION	TIME	DURATION	EVENT
CTR06	14:00 – 16 :00	2 :00	Women's Sprint Qualifying
			Men's Sprint Semifinals – Race 1
			Women's Sprint 1/32 Finals
			Men's Sprint Semifinals – Race 2
			Women's Sprint 1/32 Finals Repechages
			Men's Sprint Semifinals – Decider
CTR07	18:00 – 20 :15	2 :15	Men's Sprint Finals – Race 1
			Women's Madison Final
			Men's Sprint Finals – Race 2
			Women's Sprint 1/16 Finals
			Men's Sprint Finals – Decider
			Women's Madison Victory Ceremony
			Men's Sprint Victory Ceremony
			Women's Sprint 1/16 Finals Repechages

**Saturday 10 August 2024 – Saint-Quentin-en-Yvelines
National Velodrome**

SESSION	TIME	DURATION	EVENT
CTR08	17:00 – 20 :20	3 :20	Women’s Sprint 1/8 Finals
			Men’s Keirin First Round
			Women’s Sprint 1/8 Finals Repechages
			Men’s Madison Final
			Women’s Sprint Quarterfinals – Race 1
			Men’s Keirin Repechages
			Women’s Sprint Quarterfinals – Race 2
			Men’s Madison Victory Ceremony
			Women’s Sprint Quarterfinals – Decider

Sunday 11 August 2024 – Saint-Quentin-en-Yvelines National Velodrome



SESSION	TIME	DURATION	EVENT
CTR09	11:00 – 14:40	3 :40	Women's Omnium Scratch Race 1/4
			Women's Sprint Semifinals – Race 1
			Men's Keirin Quarterfinals
			Women's Sprint Semifinals – Race 2
			Women's Omnium Tempo Race 2/4
			Women's Sprint Semifinals – Decider
			Women's Sprint Final for places 5 th -8 th
			Men's Keirin Semifinals
			Women's Sprint Finals – Race 1
			Women's Omnium Elimination Race 3/4
			Women's Sprint Finals – Race 2
			Men's Keirin Final for places 7 th – 12 th
			Men's Keirin Final for Gold
			Women's Sprint Finals – Decider
			Men's Keirin Victory Ceremony
			Women's Omnium Points Race 4/4
			Women's Sprint Victory Ceremony
Women's Omnium Victory Ceremony			

COMPETITION FORMAT

The Olympic Cycling Track programme features six (6) events each for men and women, contested separately. The competition format for all events is the same for each gender unless stated otherwise.

The maximum number of riders/teams per race is below:

Team Sprint	Sprint	Keirin	Team Pursuit	Omnium	Madison
8 teams	30 riders	30 riders	10 teams	22 riders	15 teams

TEAM SPRINT

The Team Sprint event consists of three (3) phases: qualifying, first round and finals. The teams will be comprised of three (3) riders, each of whom must lead a lap.

The qualifying round determines the eight (8) best teams based on times, and these times are used to set the start lists for the first round.

The four (4) winning teams from the first-round race for the medals. The teams with the two (2) best times ride the final for gold. The other two (2) teams ride for bronze.

The teams who lost during the first-round race for fifth to eighth places. Those with the two (2) best times ride the final for fifth and sixth places. The other two (2) teams ride the final for seventh and eighth places.

In case of a tie (to the closest one thousandth of a second), the team with the fastest time over the last lap will be declared the winner.



SPRINT

The Sprint competition consists of 11 phases:

- Qualifying
- 1/32 finals
- 1/32 finals repechages
- 1/16 finals
- 1/16 finals repechages
- 1/8 finals
- 1/8 finals repechages
- Quarterfinals
- Semifinals – races for fifth to eighth place
- Finals race for bronze
- Finals race for gold

During the qualifying phase, all riders will complete a 200 m flying start (time trial after two-and-a-half-build-up laps) to determine the 24 fastest riders for the Sprint competition and the seeding order for the 1/32 finals.

In the case of a tie (to the closest one thousandth of a second) in the 200 m flying start, the riders concerned will be classified according to the best time in the last 100 m. If the last 100m time cannot be recorded or if the riders are still tied, the riders concerned will be classified by drawing lots.

From the 1/32 finals onwards it is a head-to-head competition. The 12 winners proceed to the 1/16 finals while the 12 losing athletes go to the 1/32 repechages and race for four (4) spots for a second chance to compete in the next phase.

In the 1/16 finals, the winners of the eight (8) heats qualify for the 1/8 finals. The four (4) remaining 1/8 final places will be filled by the winners of the 1/16 repechages.

In the 1/8 finals, the winners of the six (6) heats qualify for the quarterfinals.

The two (2) remaining quarterfinal places will be filled by the winners of two (2) 1/8 final repechages which will have three (3) riders each.

From the quarterfinals onwards, two-up matches over two (2) races (with a third deciding race, if necessary) will be held. Winners of the quarterfinals advance to the semifinals while losers ride for places 5–8.

Winners of the semifinals will compete for the gold medal while the losers ride for bronze.

KEIRIN

The Keirin event consists of five (5) stages:

- First round
- Repechages
- Quarterfinals
- Semifinals
- Finals

The Keirin is a race in which riders complete a three (3) lap sprint, after first riding three (3) laps in a bunch behind a motorcycle pacer, in order to progressively reach a specific speed. The pacer starts at 30 km/h and gradually increases to 50 km/h, before leaving the track with three (3) laps remaining.

There are 30 riders in five (5) heats of six (6) riders, with 10 riders (the first two [2] from each heat) qualifying for the Quarterfinals.

The 20 riders who do not qualify from the first round are divided into four (4) heats of five (5) riders for the Repechages. The first two (2) of each heat join the other 10 riders in Quarterfinals.

In Quarterfinals, the 18 riders are divided into three (3) heats of six (6) riders each. The first four (4) athletes of each heat proceed to the Semifinals.

The 12 riders in the Semifinals are divided into two (2) heats of six (6) riders. The first three (3) riders of each heat proceed to the Final and the other six (6) compete for places 7th – 12th.



TEAM PURSUIT

The Team Pursuit is raced by men and women over 4,000 m.

The Team Pursuit will begin with a qualifying round. The eight (8) teams that record the best times in the qualifying rounds will be matched up in the first round as follows:

- **Heat 1:** sixth fastest against seventh fastest
- **Heat 2:** fifth fastest against eighth fastest
- **Heat 3:** second fastest against third fastest
- **Heat 4:** first fastest against fourth fastest.

The winners of heats three (3) and four (4) in the first round of competition then race in the final for the gold medal.

The remaining six (6) teams are ranked by times in the first round of competition and paired as follows:

- **Two (2) fastest teams** ride for the bronze medal
- **Next two (2) fastest teams** ride for fifth and sixth places
- **Last two (2) teams** ride for seventh and eighth places

OMNIUM

The Omnium is a combined competition in which riders must compete in four (4) races in the following order: Scratch Race, Tempo Race, Elimination Race and Points Race.

For the first three (3) races, the winner of each race scores 40 points, the second 38, third 36 and so on. Riders start the fourth race (the Points Race) with all points gained over the first three (3) events. In addition, they have all points accrued in sprints or by taking/losing laps during the Points Race also totalled. The winner of the Omnium is the rider who has accumulated the most points overall.

- **Scratch Race:** A bunch race run over 10 km for men and 7.5 km for women.
- **Tempo Race:** Men cover 10 km and women cover 7.5 km. The placing is determined according to total points accumulated by riders:
 - After the first four (4) laps, sprints shall be conducted every lap. The first rider in each sprint shall be awarded one (1) point, including for the final sprint.
 - Any rider that gains a lap on the main field is awarded 20 points.
 - Any rider that loses a lap on the main field is deducted 20 points.
- **Elimination Race:** A bunch race during which the last rider crossing the line at each intermediate sprint (every two [2] laps) is eliminated.
- **Points Race:** Men cover 25 km and women cover 20 km. The final placing is determined according to accumulated points won by riders:
 - Sprints occur every 10 laps, with points awarded as follows: five (5) points for first, three (3) points for second, two (2) points for third and one (1) point for fourth. Points awarded in the last sprint after the full distance are doubled (10 points, 6 points, 4 points, 2 points).
 - Any rider that gains a lap on the main field will be awarded 20 points.
 - Any rider that loses a lap on the main field will have 20 points deducted.
 - In the event of a tie in the final ranking, the places in the final sprint of the Points Race shall break the tie.



MADISON

A relay race for teams of two (2) riders competing over 50 km (200 laps) for men and 30 km (120 laps) for women. While one (1) team member races, the other slows down, recovers and continues to circle above the uppermost blue marking on the track known as the Stayer's line.

The riders take turns to join hands and sling their teammate into the race. Teams score points in intermediate sprints held every 10 laps. The first team in each intermediate sprint is awarded five (5) points, second three (3) points, third two (2) points and fourth one (1) point. Final sprints are awarded double points. Teams gain 20 points for taking a lap and are deducted 20 points for losing a lap to the main group. The team with the most points accumulated at the finish wins.

PRE-COMPETITION PROCEDURES

RIDER CONFIRMATION AND LICENCE CONTROL

Date	Time	Location
4 August 2024	10:00 – 12:00	Technical Officials room on level 0 of the Velodrome

Rider Confirmation and Licence Control will be held in accordance with the UCI Regulations. Team Managers must confirm all starters and present all licences and racing attire.

ATHLETES' HEADSHOTS

Each athlete/team is required to attend the official headshot photoshoot, for Sport Presentation and Broadcast purposes.

Date	Time	Location
3 and 4 August 2024	09:30 - 17:00	Athlete Lounge level 0

Athletes will be required to either wear their competition outfit or their NOC uniform. Team leaders will be told in advance which one will be required for their athletes. Athletes' outfits should follow Rule 50 (no logos) of the Olympic Charter during the official photoshoot. Please note that sunglasses and tinted glasses are prohibited, and that hats or scarves should be avoided.

If athletes miss the dedicated session, a studio is open from 08:00 to 22:00 in the Olympic Village in the Bastille Services Centre building, on the first floor.

TEAM MANAGER MEETING

Each athlete/team is required to attend the official headshot photoshoot, for Sport Presentation and Broadcast purposes.

Date	Time	Location
4 August 2024	17:00 – 18:00	Press conference room on level 0 of the Velodrome

The Team Manager Meeting will be held in accordance with the UCI regulations in the presence of the President of Commissaires Panel, the UCI Technical Delegate, the UCI Commissaires, the Paris 2024 Cycling Manager, the Paris 2024 Cycling Track Discipline Manager, and Anti-Doping Officer.

All Team Managers are required to attend. The meeting will provide critical information for the athletes during competition, including information on regulations, infield operations and protocols.





RIDER NUMBER AND TRANSPONDER DISTRIBUTION.

Date	Time	Location
4 August 2024	18:00 – 18:30 (after the Team Manager meeting)	Press conference room on level 0 of the Velodrome

A representative from each NOC must attend to collect their riders' numbers and transponders.

RACE NUMBERS

Race numbers will be produced and distributed by Paris 2024 Organising Committee.

Race numbers will be made of water-resistant, tear-proof material. They must be attached to competition skinsuits with pins (or, in accordance with international event regulations, to skinsuit pockets).

WATER BOTTLES

Water bottles will be provided to Cycling Track athletes and will be distributed to one (1) representative of each NOC on the first day of training in the infield team pens.

Please note that all water bottles used in training and competition must meet the requirements of Rule 50 and the Byelaw to Rule 50 of the Olympic Charter, and the IOC's Manufacturer Identification Guidelines for the Paris 2024 Olympic Games.

COMPETITION PROCEDURES

WARM-UP

The track will be open for warm-up 90 minutes before the start of the session for riders competing in that session only.

The track will close 10 minutes before the start of each competition session.

BIKE CHECK PROCEDURE

All equipment must adhere to the principles and requirements outlined in the **UCI Regulations**. For track events specifically, equipment used during the Olympic Games must comply with the requirements stipulated in the **Olympic Track Equipment Registration Process**, as per article 11.1.010.

Before each competition, the equipment to be used must be presented reasonably in advance at the bike control area to the International Technical Officer, who will carry out the verification of the equipment that consists of but not limited to, measure and weight.

It will be possible for NOCs to carry out a pre-check of bikes before competitions. More details will be communicated later.

ON-BOARD CAMERAS

On-board cameras will be used by OBS during competitions.

Please find below the specs for the mount of the cameras used at Cycling Track (MK4 system):

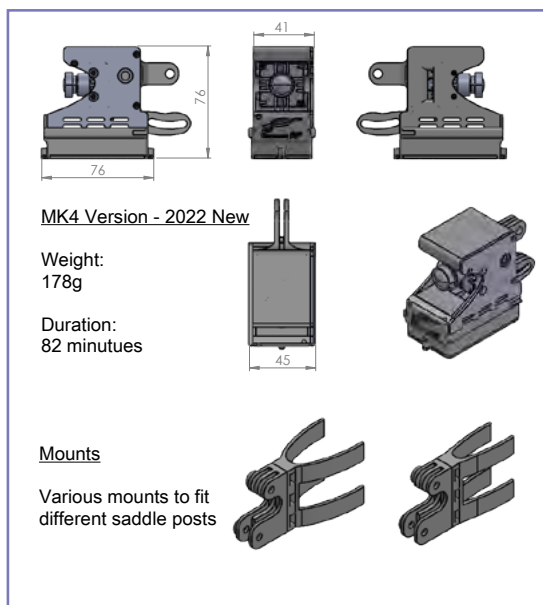

Dimensions and weights do not include mounts. Mounting system remains the same as previous versions.

Dummies will use plastics design from new MK4 version weighted to match live systems.



ATHLETE WAITING AREA

Depending on the event, an Athlete Waiting Area with seating has been provided on both straights for riders waiting to access the track for their competition.

All riders must wait in this designated waiting area before their race. Riders are requested to arrive at this area in good time, and to access the track from these seats when directed.

ATHLETES' ACCESS TO THE TRACK

Except for timed events, riders must enter the track on the home straight and leave the track on the back straight.

ACCESS RAMP AND LANDINGS

During each race, personnel will not be allowed to stand on the track access ramps, landings or steps, starter podium or award ceremony stage except for the following persons:

- Technical Officials with direct duties in relation to the race in progress
- The UCI Technical Delegate
- The Track Chiefs who operate the access gates and persons authorised by Paris 2024
- Paris 2024 Competition Management

All other personnel must remain within the infield.

During competitions, except for the Team Pursuit, all team staff must stay out of the safety zone and the competition track.

During the Team Pursuit, only one (1) coach per NOC will be permitted in the safety zone. Spectating from the track access gate landings or ramps is not allowed.

For bunch races, a limited number of seats in the stands next to the track will be available for coaches. Please go to the Sport Information Desk and make your reservation. One (1) position can be reserved and one (1) person per NOC, with the Blue Zone accreditation can access the platform. For the reservations, the first-come, first-served rule will apply. Please note that the P Accreditation does not give access to this area.

ACCREDITED AND TEAM SEATING

Same Discipline Athletes seating is available in the stands on level 3 on the finish line side. All athletes and team officials must present their accreditation (2 + Blue) to access these seats.

Please note that the “P” accreditation does not give access to these areas.

POST COMPETITION PROCEDURES

ATHLETES' EXIT OF THE TRACK

All athletes will have to leave the track through the back straight line access gate only, regardless of the event. This will ensure that they are properly directed to the mixed zone by Paris 2024 staff.

After each final, medallists will be directed to the victory ceremonies waiting area unless otherwise instructed.

MIXED ZONE

A mixed zone, where accredited media will be able to interview the athletes after the competitions, is located in the track infield. All athletes must pass through the mixed zone when exiting the track after competing. There is no obligation for athletes to interact with the media. This procedure must be followed by all riders.

2 3 4

**COMPETITION
VENUE**

SAINT-QUENTIN-EN-YVELINES NATIONAL VELODROME

1 rue Laurent Fignon – 78180 Montigny-le-Bretonneux – France

Located in Montigny-le-Bretonneux, 39 kilometres from the Olympic Village, the Saint-Quentin-en-Yvelines National Velodrome was built, and has been operational, for more than 10 years. Created specifically for the purpose of organising international competitions, it has successfully hosted the main events on the UCI calendar. For the Paris 2024 Olympic Games, the gross capacity will be around 5,000 seats.

Saint-Quentin-en-Yvelines National Velodrome will also host the BMX Racing event during the Olympic Games.

VENUE ACCESS

The TA transport pick-up area is located in the multi-functional area by the team storage containers, next to the main athletes' entrance.

Paris 2024 strongly recommends the use of the TA transport service for travel between the Paris 2024 Village or **Paris 2024 Bed & Return** hotels and the Saint-Quentin-en-Yvelines National Velodrome.

→ VAPP ACCREDITED VEHICLES

Athletes travelling in VAPP-accredited vehicles can only be dropped off in the GEN unloading area on Rue des Louvières, 300m from the main athletes' entrance to the National Velodrome, or in the P3 NOC and P6 NOC car parks (different car parks may be allocated to teams depending on the size and type of vehicle).

VAPP-accredited vehicles can also use this area to load and unload their equipment.

Athletes and team officials who do not use TA services to travel to Saint-Quentin-en-Yvelines National Velodrome must pass through the Pedestrian Screening Area 2 (PSA 2) before entering the venue.



Vehicles without VAPP will not be able to access these areas. However, they will be able to drop off their team members safely at Rue du Fort de Saint-Cyr, Montigny-le-Bretonneux (near the Best Western Paris Saint-Quentin hotel).

Please note that any possessions and/or vehicles left in the vicinity of the site remains the sole responsibility of the owner, or as the case may be, the person who has the rights to use them.

Paris 2024, in its capacity as organiser of the Olympic and Paralympic Games, will not be considered responsible for the object and/or vehicle, nor of its contents. Paris 2024 cannot assume any obligation, in particular of custody or surveillance in this respect.

→ TA SERVICES

TA services will be provided to athletes travelling between the Olympic Village or the Paris 2024 Bed & Return hotels (except for the Best Western Paris Saint-Quentin) and the Saint-Quentin-en-Yvelines National Velodrome.

The schedule of TA transport services will be available at the Sport Information Desks (SID) at the Velodrome.

Each NOC will be responsible for its equipment and riders' safety in case any athlete decides to ride the route between the Paris 2024 Bed & Return hotels or other accommodation and the Velodrome.

Athletes or NOC officials wishing to access the Velodrome with their bikes (outside the equipment drop-off and pick-up periods) must have a "tools of the trade" sticker on their accreditation. They will also have to use Rue Laurent Fignon and pass through VSA1 to access the Velodrome.

More details on the distribution of the "tools of the trade" stickers will be communicated later by the NCS team.

Athletes and NOC members loaded in the GEN zone, rue des Louvières, must access the velodrome via the PSA2. They will not be able to enter with their bikes at this check point.

Athletes and NOC members dropping off at P3 (Ibis car park) may access the velodrome via the VSA1 (rue Laurent Fignon).

Attention: Given the passage of the men's road race in the vicinity of the Velodrome on 3 August 2024 access will be disrupted in the afternoon. Traffic around the velodrome as well as access to the GEN drop-off area, the P3 NOC and P6 NOC car parks will be completely inaccessible from 13:00 to 15:00.

In addition, it will not be possible to pass on Avenue du Pas du Lac, in the opposite direction of the road race route, during the road closure from 11:00 to 16:40. More information will be communicated as soon as possible.



Please note that, for logistical purposes, all vehicles with a P3CNO vehicle accreditation will be directed to the P6CNO car park on 3rd August.

→ EQUIPMENT DROP-OFF

It will be possible to access the Saint-Quentin-en-Yvelines National Velodrome and unload drop-off sports equipment on 29 and 30 July 2024. For exceptional requests, please check for availability contacting trackcycling@paris2024.org.

Each NOC will be allocated a one-hour slot, subject to reservation, in order to unload drop-off their equipment in their assigned storage area (outdoor containers and team pens in the centre of the track).

In view of the limited space available for these operations, a maximum of three (3) lorry trucks of 3.5 tonnes or maximum equivalent per NOC will be accepted during these operations. All requests will be analysed and may be modified by Paris 2024 in cases



where requests exceed estimated needs (depending on the number of athletes entered per NOC).

At the end of this hour, all NOC vehicles must exit the venue. For vehicles with a proper VAPP, it will be possible to park in the dedicated parking area, close to the PSA 2, insofar as the vehicles are VAPP accredited. If this is not the case, vehicles must leave the venue.

After the equipment has been dropped off and the NOC vehicle is parked out of the venue, NOC staff will be authorised to walk to the Velodrome via the Pedestrian Screening Area 2 (PSA2) in order to continue their setting up. The venue will be open for this purpose on the days mentioned above from 08:00 to 15:00.

All persons accessing the venue for equipment drop-off operations on 29 and 30 July must hold the proper valid accreditation.

Further information regarding equipment drop-off, vehicle access, accreditation procedures and reservations can be found in the appendix Cycling Track of this guide. The “first-come, first-served” rule will apply.

→ DAILY EQUIPMENT TRANSPORT

Bikes will be transported by lorry from the Village to the National Velodrome daily. One (1) return journey per day will be organised. The equipment transported must be dropped off by a member of the NOC and picked up on arrival at the venue by the same person or another person from the NOC. No equipment may be transported or delivered without the presence of a member of the NOC.

For logistical reasons, NOCs staying in the Olympic Village must communicate the Sport information desk at the velodrome if they need to transport sport equipment the day before and indicate the number of bikes to be transported.

More details of this operation will be shared soon through the NCS team.

→ EQUIPMENT PICK-UP

Equipment pick-up operations will be organised on Sunday 11 August from 15:15 to 18:30 and on Monday 12 August from 08:30 to 16:00.

Each NOC must reserve a time slot to access the Velodrome with their vehicles. The same conditions of access, accreditation and procedures will apply as for equipment drop-off operations.

Paris 2024 will inform the NOCs as quickly as possible of the access procedures for lorries and other vehicles. The “first-come, first-served” rule will apply.

For NOCs staying in Paris 2024 Bed & Return hotels and requiring the services of the OAP, a process will shortly be communicated for the handling of sports equipment and baggage bound for airports.

You can find in the Cycling Track appendix in this guide some additional information related to the Arrivals and Departures (AND) operations.

→ CLOSING CEREMONY OF THE PARIS 2024 OLYMPIC GAMES

On Sunday 11 August, the last day of the Cycling Track competitions, shuttles will be set up for NOC's staying in Paris 2024 hotels to reach the Closing Ceremony of the Paris 2024 Olympic Games:

Departure:

Best Western Saint-Quentin: Departure at 16:00 – Arrival at the Olympic Village at 17:00

Mercure Paris Vélizy: Departure at 16:10 – Arrival at the Olympic Village at 17:00

From the National Velodrome for the Mercure Vélizy and B&B Saint-Quentin: last departure at 16:30 – Arrival at the Olympic Village at 17:20

Return:

Returns to Paris 2024 hotels must be made by the “Early Departure shuttles” from the Stade de France to the Olympic Village and then by a second shuttle towards the Paris 2024 Bed and Return Hotels.

Early Departure shuttle from Stade de France to the Olympic Village from 22:17 to 22:27:

Arrival Transport Mall (TM) from 22:35 to 22:45

Departure at 22:45 from Stade de France:

* Arrival** Mercure Paris Vélizy: 23:55

* Arrival** B&B St Quentin: 00:40

*Arrival** Best Western St Quentin: 00:45

- Departure at 23:00 from the Stade de France:





* Arrival** Mercure Paris Vélizy: 00:10

* Arrival** B&B St Quentin: 00:55

*Arrival** Best Western St Quentin: 01:00

**Estimated arrival times

NOCs and athletes are strongly discouraged from making their own way to the Olympic Village.

Additionally, the schedules communicated by the Ceremonies teams must be respected.

It is also strongly recommended that NOCs do not drive their own cars to and from the Closing Ceremony in Paris. Traffic will be extremely difficult due to local security and traffic operations.

VENUE MAP

[See Appendices](#)

FIELD OF PLAY (FOP)

CHARACTERISTICS OF THE TRACK	
Length	250 m
Width	8 m
Surface	Siberian pine
Bend	43.8°
Straight	13°

VENUE FACILITIES & SERVICES

The competition venue will have the following services and facilities:

→ ATHLETE LOUNGE

The Athlete Lounge is located on level 0 and will be equipped with chairs, tables, sofas and a television displaying the live competition feed. It will be open from

the time teams arrive at the venue until 30 minutes after the end of training or competitions.

A refreshment station serving whole fruits, cereal bars, Coca-Cola drinks and hot drinks will be available for athletes and team officials.

Please note that only two (2) + Blue accreditation gives access to this room.

→ **SPORT INFORMATION DESK (SID)**

There will be two (2) Sport Information Desks (SID) at the Velodrome: one on the field of play, on the riders' side (back straight), and the other one in the Athlete Lounge, on level 0.

Information available at the SIDs will include:

- Sports Publications
- Event Announcements
- Venue Maps
- Competition & Training Schedule
- Start List
- Results
- Printing
- Transport
- Food and Beverage
- Medical Provision
- Lunch box booking
- Athlete Seating
- Wi-Fi Access



SPORT INFORMATION DESK – HOURS OF OPERATIONS

Wednesday 31 July 2024 Training: Day 1	08:00 – 17:30
Thursday 1 August 2024 Training: Day 2	08:00 – 17:30
Friday 2 August 2024 Training: Day 3	08:00 – 17:30
Saturday 3 August 2024 Training: Day 4	08:00 – 17:30
Sunday 4 August 2024 Training: Day 5	08:00 – 18:30
Monday 5 August 2024 Competition: Day 1	09:00 – 20:50
Tuesday 6 August 2024 Competition: Day 2	09:15 – 21:00
Wednesday 7 August 2024 Competition: Day 3	08:00 – 20:55
Thursday 8 August 2024 Competition: Day 4	09:00 – 20:55
Friday 9 August 2024 Competition: Day 5	08:15 – 20:45
Saturday 10 August 2024 Competition: Day 6	10:30 – 20:50
Sunday 11 August 2024 Competition: Day 7	08:05 – 15:15

→ CHANGING ROOMS AND SHOWERS

Separate Male and Female changing room facilities and toilets will be available and are located on levels -1 and 0.

→ MASSAGE ROOMS

Massage areas are available on level 0. Teams wishing to use them must book in advance. The booking procedure will be communicated posteriorly.

Should there be more requests than availability, the Paris 2024 Services team reserves the right to give priority to certain requests to enable all NOCs to take advantage of this service.

→ FOOD AND BEVERAGE

During training days, in a limited number, lunch boxes may be ordered at least 48 hours in advance for athletes and team officials. For requests for the first two (2) days please use the link or the QR code in the Cycling Track appendix of this guide.

On competition days, hot buffet meals will be available in the NOC catering area outside the Velodrome, in the multi-functional area near the team cabins for athletes and team officials that present 2 + Blue on their accreditations.

In addition, cold drinks (water and isotonic drinks supplied by Coca-Cola on a self-service basis in dedicated fridges), hot drinks (tea and coffee) and light snacks (whole fruits and cereal bars) will be provided in the Athlete Lounge throughout training and competition days.

Operational times will be communicated to NOCs afterwards.

Bottled water and isotonic drinks will also be available in large coolers in the infield for NOCs on training and competition days.

→ ICE AND TOWEL DISTRIBUTION

On training and competition days, ice (in coolers) and towels will be provided daily to NOCs on their arrival at the venue. Each NOC will be able to go to the sports equipment storage area to pick up their equipment for the day.

→ BIKE MAINTENANCE AND REPAIR

A neutral service by Shimano will be available to competing athletes, at no charge, on all training and competition days. The repair area will be located on the FOP.

→ TEAM CABINS

Storage containers for bikes and equipment measuring 6 m long by 2.4 m wide will be allocated to NOCs according to the number of riders registered for each NOC. The storage container area will be provided with 24/7 security service.



The containers will be located outside the Velodrome, in the multi-functional area near the athletes' entrance. They will be available from the 29th July to 12th August. Access times will be communicated at a later date.

Each NOC will have access to electricity, and three compressors will be installed in the multi-functional area.

On arrival at the Velodrome, NOCs must go to the Sport Information Desk in the infield to collect their cabin key. All keys must be signed for upon collection; NOCs will be charged for each unreturned key. NOCs may only use the cabin(s) allocated to them.

→ TEAM PENS

Each NOC will be allocated a pen within the infield, the size of which will be determined by the number of riders per NOC.

Each pen will be equipped with:

- Chairs
- Table(s)
- 230V Power Sockets (sockets in France require a type-E plug)

Kettles, coffee machines, fridges and other household appliances will not be allowed in the infield – to avoid power cuts.

Bikes not used on training days or during each day of competition must be stored in the team cabins outside the Velodrome, to free up the infield and allow everyone the best possible conditions.

→ ROLLERS AND BIKE RACKS

Bike racks and up to two (2) rollers will be available for NOCs to use on loan. They must be used in the warm-up area. NOCs will be charged for any equipment that is not returned or damaged.

→ VIDEO ANALYST PLATFORM

22 Video Analyst positions will be available. A space is dedicated to them in the stands on level 3 on the back straight. One (1) position can be reserved and one (1) person per NOC, with the Blue Zone accreditation can access the platform. The booking procedure can be found in the Cycling Track appendix.

LAN cabled Internet, as well as a Wi-Fi connection and electricity, will be available in this area for each NOC.

Please note that the “P” Accreditation does not give access to this area.

→ DOPING CONTROL STATION

The Doping Control Station is located on level 0, inside the Velodrome. Further details on the Paris 2024 Doping Control programme will be communicated centrally to each NOC.

→ MEDICAL SERVICES

Athlete medical services will be provided in accordance with IF requirements and Olympic regulations for the discipline in question and will be available during training days and on competition days.

The athlete medical area will be situated on the FOP and on level -1 close to the athletes’ main entrance of the Velodrome.

The Paris 2024 medical team will provide services such as first aid, emergency care, sports medicine and physical therapy to athletes, team officials and technical officials. On competition days, the medical team will consist of three (3) emergency doctors, three (3) nurses, one (1) sports doctor, two (2) physiotherapists and first aiders. Ambulances will be on standby at the Velodrome during medical service hours.

In addition, a mobile medical centre (radiology truck) will be on site if necessary and operational on competition days, from the start of training to the end of competition sessions.

→ NEAREST HOSPITALS:

Emergency Medicine – Hôpital Privé Ouest Parisien/ 4.9 km
14 Rue Castiglione del Lago
78190 Trappes
+33 (0)1 30 69 46 07

Hôpital André Mignot Centre Hospitalier de Versailles (Le Chesnay)/12.4 km
177, rue de Versailles
78150 Le Chesnay
+33 (0)1 39 63 91 33





Centre Hospitalier (Rambouillet)/24.2km
 5-7 rue Pierre et Marie Curie
 78120 Rambouillet
 +33 (0)1 34 83 78 78

→ LOST AND FOUND

All reports of lost items by athletes and team officials at the competition venue should be directed to the SID, so should any found item.

→ ADDITIONAL INFORMATION

The Velodrome does **not** have the following:

- Gym
- Hydrotherapy
- Ice Bath

VENUE ACCREDITATION HELP OFFICE (VAHO)

Accreditation is the process of identifying people at the Olympic Games, allowing them necessary access to perform their role.

A Venue Accreditation Help Office (VAHO) will be available on site to deal with any accreditation problems. Athletes, Team Officials, Technical Officials and International Federations cannot enter the venue without their accreditation. VAHO is an accreditation management office. All groups of people may come to the VAHO for the following services:

Services	Pre-Valid Card Validation	Yes
	Lost/Stolen/Damaged OIAC/PIAC Replacement	Yes
	Day Pass Distribution	Yes
	Help Desk	No
	Accreditation Production	No

OLYMPIC GAMES OPERATION DATES AND TIMES

Non-competition days (Drop-off and Training)	29 July to 2 August: 08:00 – 20:00 3 to 4 August: 08:00 – 17:00
Competition days	5 August 2024: 13:30 – 18:30
	6 August 2024: 14:00 – 19:00
	7 August 2024: 09:15 – 18:00
	8 August 2024: 13:30 – 18:30
	9 August 2024: 10:30 – 18:30
	10 August 2024: 13:30 – 18:30
	11 August 2024: 07:30 – 12:30

3 4 5

TRAINING

TRAINING VENUE

Training for the Cycling Track competition will take place at the Saint-Quentin-en-Yvelines National Velodrome, which will be open for training from Wednesday 31 July to Sunday 4 August 2024.

TRAINING SESSIONS

Training sessions will be divided into 5 groups of 1h30 each, and will take place from 9:30 to 17:00, from Wednesday 31 July to Sunday 4 August.

The groups will be defined in agreement with the UCI and communicated to NOCs, at a later date.

On 3 and 4 August 2024, starting block practice can be carried out during the last 15 minutes of each training session (subject to change). The use of derny bikes is not allowed on training sessions.

On competition days, training sessions will be organised as follows:

Date (DD/MM/YYYY)	Group 1	Group 2	Group 3
05/08/2024	10:30 – 12:00	12:00 – 13:30	13:30 – 15:00
06/08/2024	10:30 – 12:00	12:00 – 13:30	13:30 – 15:00
07/08/2024	9:00 – 10:00 Sprint	10:00 – 11:00 Endurance	
08/08/2024	10:30 – 12:00	12:00 – 13:30	13:30 – 15:00
09/08/2024	9:30 – 10:30 Endurance	10:30 – 11:00 Madison	11:00 – 12:00 Sprint
10/08/2024	13:30 – 15:00 Endurance		
11/08/2024			

*These times and groups are for information only and may be modified.

**Please note that this schedule may change on some training days.

All training equipment provided by Paris 2024 will be approved by UCI and will comply with Rule 50 and Bye-Law to Rule 50 of the IOC Olympic Charter.



TRAINING REGULATIONS

Training sessions will be open to the media. They will have access to the mixed zone and the stands but will not be authorised to interact with the athletes unless prior agreement has been reached with NOCs. The NOC and Sport Press attachés will agree to provide the best possible conditions for “organised” interviews before or after the training sessions, which must take place in the mixed zone.

TRAINING FACILITIES

Training facilities at the Saint-Quentin-en-Yvelines National Velodrome will be the same as the competition facilities. See above for more information on the venue’s facilities and services.

VENUE ACCESS

VENUE TRANSPORT ACCESS

As the training venue is the same as the competition venue, access to the Saint-Quentin-en-Yvelines National Velodrome can be found in the “Venue access” chapter in the “Competition” section.

DEDICATED TRAINING VENUE ACCESS

Training venues will be accessible only to holders of a valid Olympic Identity and Accreditation Card. NOCs will be granted access to one or more training venues, according to the sport code(s) printed on their accreditation.

Specific passes for training venues will no longer exist for the Paris 2024 Games, but the requirements are integrated into “P” accreditation quotas:

- One (1) to six (6) athletes: one (1) “P”.
- More than six (6) athletes: two (2) “P”.

NOC members with a “P” accreditation may have access to the venue and infield on training days.

On competition days, “P” accredited NOCs will have access to the venue and the infield during training times but must leave the venue at the end of the training period if they do not have tickets to attend the day’s competition in the stands. Any non-compliance with the above procedure will not be tolerated and measures will be taken to ensure this does not happen again.

The velodrome will be accessible to “P” accredited from 31 July to 10 August 2024 under the conditions specified above.

456

CYCLING TRACK APPENDIX

1 - ATHLETES' SPORT EQUIPMENT DROP-OFF

It will be possible to access the Saint-Quentin-en-Yvelines National Velodrome and unload athletes' sports equipment on 29 and 30 July 2024 from 08:00 to 15:00.

For exceptional requests, please check the availability by contacting:

trackcycling@paris2024.org

Access to the drop-off area will be via Venue Screening Area VSA1.

IMPORTANT: All persons accessing the venue for equipment drop-off operations on July 29th and 30th must hold a proper valid accreditation.

In case a team member comes on a TA bus without having validated his/her pre-valid card (PVC), upon arrival at the Velodrome and after disembarking from the bus, the team member will be directed to Venue Accreditation Help Office (VAHO) for the PVC validation.

Those coming with their own vehicles, before going to VSA1, are required to go to VAHO for PVC validation. Access to any area of the Velodrome, including the load/unload area, will not be allowed without a validated PVC.

Drop-off dates and slots at the velodrome

29 JULY		
Type	From	To
Vehicles without a partition & light cars	08:00	09:00
	09:00	10:00
	10:00	11:00
Vehicles with a partition (trucks)	08:00	09:00
	10:00	11:00
	11:00	12:00
	12:00	13:00
	13:00	14:00

30 JULY		
Type	From	To
Vehicles without a partition & light cars	08:00	09:00
	09:00	10:00
	10:00	11:00
	11:00	12:00
Vehicles with a partition (trucks)	08:00	09:00
	10:00	11:00
	11:00	12:00
	12:00	13:00
	13:00	14:00





Please note that times and slots may be adjusted or changed according to demand.

How is it going to work?

Each NOC will be allocated a one-hour slot, subject to reservation, to unload/drop-off, the equipment in their assigned storage area (outdoor containers and team pens in the infield). For the reservations, first-come, first-served rule will apply.

In view of the limited space available for these operations, a maximum of three (3) lorry trucks of 3.5 tons or maximum equivalent per NOC will be accepted during these operations. All requests will be analysed and may be modified by Paris 2024 in cases where requests exceed estimated needs (depending on the number of athletes entered per NOC).

At the end of this hour, all NOC vehicles must exit the venue. For vehicles with a proper VAPP, it will be possible to park in the dedicated parking area, close to the Pedestrian Screening Area (PSA 2).

After the equipment has been dropped off and the NOC vehicle is parked out of the venue, NOC staff will be authorised to walk to the Velodrome via the PSA2 in order to continue their setting up. The venue will be open for this purpose on the days mentioned above from 08:00 to 15:00.

Below there are more detailed information on the steps to be taken in advance, according to the different arrival scenarios:

SCENARIO 1

→ ARRIVING IN PARIS AND GOING TO THE OLYMPIC VILLAGE (OLV):

If a team leader is arriving in Paris through one of the Primary Ports of Entry (PPOE), either CDG or ORY airports, P24 official transport will provide transport/transfer to the Olympic Village along with the sports equipment. However, the team leader will be able to choose one (1) of the two (2) options:

Option A: Use the P24 transfer service managed by P24 Logistics team to transfer the sport equipment to the Velodrome. In this case, the following steps must be followed:

Use ADS to inform arrival time, number of people and amount of baggage to be transported. Once you arrive at the OLV, the equipment will be unloaded and will pass through the TPC (Team Processing Centre). After that, NOC will take the equipment to the athletes' sport equipment drop-off area, close to the Transport Mall and will handle it to LOG team. There will be two (2) daily departures from the

village to the venue. The first one will be at 07:00 and the second at 12:00. If you arrive in the afternoon or in the evening, your equipment will be kept by LOG and transported the day after your arrival. LOG team will inform the delivery time and a member of your team will be needed at the time of unloading the equipment at the Velodrome. If you need transportation from the village to the venue on July 29 or 30, please see below the TA bus times:

From OLV to VEL
08:00
10:30

From VEL to OLV
15:10

If the times above do not suit you, P24 offers the TC bus line (OLV -> Porte Maillot -> Velodrome). Estimated travel time: 1:00.

Option B: Use your own vehicle to take your equipment to the Velodrome:

- Use the link or the QR code at the end of this chapter to access the booking system. Once you make your reservation, an email confirming your slot will be sent to your email address.
- If your vehicle has a metallic partition between the driver and the equipment (truck or cargo van, for example), it will be necessary to schedule an inspection of the vehicle and material via Master Delivery Schedule (MDS). On the day of the delivery, go to the Remote Material Screening Area (RMSS), follow the verification procedures as instructed in the MDS guide and then proceed to the Velodrome to drop off the equipment at the window in which you booked. Enter the line indicating MDS delivery and wait for the security check to access the unloading area. Note: It is recommended to go to the RMSS not earlier than two (2) hours before the time of delivery of the material at the venue.
- If the vehicle used is a light vehicle or has no separation between the driver and the equipment, go to the Velodrome on the day and time you made the reservation (we recommend that you arrive 15 minutes in advance). Enter the line indicating “SPT delivery”, wait for the security check and then access the unloading area.





SCENARIO 2

→ IN PARIS AND GOING TO BED RETURN HOTELS:

if you arrive in Paris through one of the Primary Ports of Entry (PPOE), either CDG or ORY airports, P24 official transport will provide transport/transfer to the team(s) member(s) to their respective hotel, along with the sports equipment. In this case, the following steps must be followed:

Option A: Use the P24 transfer service managed by the P24 Logistics team to transfer the equipment to the Velodrome:

Use ADS to enter arrival time, number of people and amount of baggage to be transported. LOG team will work on the delivery schedule and bring your equipment to the venue. There will be two (2) stops: the first is at the bed return hotel to unload the NOC luggage, the second one at the competition venue to drop the athletes' sport equipment. LOG team will inform what time an NOC member must be at the Velodrome to collect the equipment. It is necessary a team member to be present at the venue at the time of unloading the equipment. If you need transportation from the Bed Return Hotel to the venue on July 29th or 30th, please see below the TA bus times:

From BR Hotel to VEL*		From VEL to BR Hotels*	
Mercure	B&B	15:00	
7:50	8:20		
11:20	11:50		

*Please note that this bus line only serves Mercure Paris Vélizy and B&B Saint-Quentin-en-Yvelines

Important: Please inform SPT team as soon as possible if your arrival will be after 13:00 contacting trackcycling@paris2024.org.

Option B: Use your own vehicle to take your equipment to the Velodrome:

- Use the link or the QR code at the end of this chapter to access the booking system. Once you make your reservation, an email confirming your slot will be sent to your email address.
- If your vehicle has a metallic partition between the driver and the equipment (truck or cargo van, for example), it will be necessary to schedule an inspection of the vehicle and material via Master Delivery Schedule (MDS). On the day of the delivery, go to the Remote Material Screening Area (RMSS), follow the verification procedures as instructed in the MDS guide (link/attachment) and then proceed

to the Velodrome to drop off the equipment at the window in which you booked. Enter the line indicating MDS delivery and wait for the security check to access the unloading area. Note: It is recommended to go to the RMSS not earlier than two (2) hours before the time of delivery of the material at the venue.

- If the vehicle used is a light vehicle or has no separation between the driver and the equipment, go to the Velodrome on the day and time you made the reservation (we recommend that you arrive 15 minutes in advance). Enter the line indicating “SPT delivery”, wait for the security check and then access the unloading area.

SCENARIO 3

→ ARRIVING IN PARIS AND GOING TO NON-OFFICIAL ACCOMMODATIONS:

If you arrive in Paris by car, and/or you are staying in a non-official hotel, P24 will not be able to offer transfer services. In this case, you must manage both your team and sports equipment movements to your hotel and the Velodrome. In this case, the steps below must be followed:

- Use the link or the QR code at the end of this chapter to access the booking system. Once you make your reservation, an email confirming your slot will be sent to your email address.
- If your vehicle has a metallic partition between the driver and the equipment (truck or cargo van, for example), it will be necessary to schedule an inspection of the vehicle and material via Master Delivery Schedule (MDS). On the day of the delivery, go to the Remote Material Screening Area (RMSS), follow the verification procedures as instructed in the MDS guide and then proceed to the Velodrome to drop off the equipment at the window in which you booked. Enter the line indicating MDS delivery and wait for the security check to access the unloading area. Note: It is recommended to go to the RMSS not earlier than two (2) hours before the time of delivery of the material at the venue.
- If the vehicle used is a light vehicle or has no separation between the driver and the equipment, go to the Velodrome on the day and time you made the reservation (we recommend that you arrive 15 minutes in advance). Enter the line indicating “SPT delivery”, wait for the security check and then access the unloading area.





2 - ATHLETES' SPORT EQUIPMENT PICK-UP

Equipment pick-up operations will be organised on Sunday 11 August from 15:15 to 18:30, and on Monday 12 August from 08:30 to 16:00.

IMPORTANT: All persons accessing the venue for equipment pick-up operations on these dates must hold a proper valid accreditation.

11 AUGUST		
Type	From	To
Vehicles without a partition, light cars & Vehicles with a partition (trucks)	15:15	16:15
	16:15	17:15
	17:15	18:15

12 AUGUST		
Type	From	To
Vehicles without a partition, light cars & Vehicles with a partition (trucks)	08:30	09:30
	09:30	10:30
	10:30	11:30
	11:30	12:30
	12:30	13:30
	13:30	14:30
	14:30	15:30

WHAT TO DO IN ADVANCE?

Each NOC must reserve a time slot to access the Velodrome with their vehicles. The same conditions of access, accreditation and procedures will apply as for equipment drop-off operations. For the reservations, the first-come, first-served rule will apply.

Use the link or the QR code at the end of this chapter to access the booking system. Once you make your reservation, an email confirming your slot will be sent to your email address.

HOW IS IT GOING TO WORK?

For pick-up days, it will not be necessary to use MDS system if your vehicle is empty.

On the day and time scheduled, go to the Velodrome (we recommend that you arrive 15 minutes in advance). Enter the line indicating “SPT delivery”, wait for the security check and then access the loading/unloading area.

Each NOC will be allocated a one-hour slot, subject to reservation, to load their equipment from their assigned storage area (outdoor containers and team pens in the infield). For the reservations, first-come, first-served rule will apply.

At the end of this hour, all NOC vehicles must exit the venue.

In view of the limited space available for these operations, a maximum of three (3) lorry trucks of 3.5 tons or maximum equivalent per NOC will be accepted. All requests will be analysed and may be modified by Paris 2024 in cases where requests exceed estimated needs (depending on the number of athletes entered per NOC).

If you need transportation from the village or Bed Return Hotel* to the velodrome on Aug 12th, please see below the TA bus times:

From OLV to VEL
→ 09:00

From VEL to OLV
→ 15:00

If the times above do not suit you, P24 offers the TC bus line (OLV -> Porte Maillot -> Velodrome). Estimated travel time: 1:00.

From BR Hotel to VEL*	
→ Mercure	→ B&B
→ 7:50	→ 8:20
→ 10:20	→ 10:50

From VEL to BR Hotels*
→ 12:00
→ 16:00

*Please note that this bus line only serves Mercure Paris Vélizy and B&B Saint-Quentin-en-Yvelines

For NOCs staying in Paris 2024 Bed Return hotels and requiring the services of the Off – Airport Processing (OAP), a process will shortly be communicated by AND and NCS for the handling of athletes’ sports equipment and baggage bound for airports.





3 - VEHICLE ACCESS PARKING PERMIT - VAPPS

To drop off and pick up your material at the venue, it is necessary that the vehicle(s) present(s) a temporary VAPP for this operation.

P24 will allocate up to three (3) temporary VAPPS per NOC that will allow access to the unloading and loading area at the velodrome on 29 and 30 July for drop off and/or on 11 and 12 August for equipment pick up according to previously booked times.

These VAPPS will also give access to a car park near the velodrome (approx. 300 m) and it will be possible for trucks or vans/vehicles over 1,90 m high and be up to 7.5 m long and 3 m wide to park the vehicles between 29 July and 12 August if you use them for daily operational transport.

IMPORTANT: This temporary VAPP does not give access to the Olympic Lanes.

Since there is a limited number of spots for NOC cars, should there be more requests than availability, the Paris 2024 Services team reserves the right to give priority to certain requests to enable all NOCs to take advantage of this service.

To apply for these VAPPS, please use the link or the QR code at the end of this chapter.

You will need to provide the following information:

- Operation that the vehicles will be used.
- Plate number.
- Type of vehicle.
- Vehicle model.

After receiving this form, P24 will contact you confirming receipt of the same and will inform you of the date and place where the VAPPS will be distributed.

IMPORTANT: Please note that any possessions and/or vehicles left in the vicinity of the site remains the sole responsibility of the owner, or as the case may be, the person who has the rights to use them.

Paris 2024, in its capacity as the organiser of the Olympic and Paralympic Games, will not be considered responsible for the object and/or vehicle, nor of its contents. Paris 2024 cannot assume any obligation, in particular of custody or surveillance in this respect.

4 - VIDEO ANALYST PLATFORM

22 Video Analyst positions will be available, in a dedicated space in the stands on level 3 on the back straight. One (1) position and one (1) person per NOC can be reserved. Team members with Blue Zone on their accreditation will be able to access the platform.

The booking procedure will be made through the link or the QR code at the end of this chapter.

Once the requests are done, an email will be sent confirming your request and Paris 2024 will allocate the NOC accordingly.

5 - LINK FOR BOOKINGS SYSTEM, VAPPS REQUEST AND QR CODE

[cycling track - olympic games paris 2024 - booking form](#)

QR CODE for booking system





6 - MDS GUIDELINES EXTRACT

Acceptable vehicle types

Vendors, partners, sponsors and MRHs are to provide dedicated vehicles for Olympic or Paralympic operations. All delivery vehicles should meet the following guidelines:

- It is encouraged to utilise vehicles with tail lifts & MHE.
- The cargo compartment is to be separated from the driver compartment by a physical barrier, with no internal access to the cargo compartment by vehicle occupants.
- Cargo compartment doors or access points are to be equipped with locking mechanisms to which security seals can be applied.
- Cargo compartment construction should consist of:
 - Solid metal side walls; or
 - Soft-walled cargo compartments (side loading), where the soft walls are constructed of a durable material with no defects and all access points can be secured and sealed. Security cables (“Câble TIR” in French) is mandatory for curtainsider vehicles.

During Games-time operations, all vehicles, trailers, and drivers will have to respect the Clean Venue principles unless previously agreed in writing by Paris 2024 Logistics, meaning that no third parties’ brands should be visible on sites.

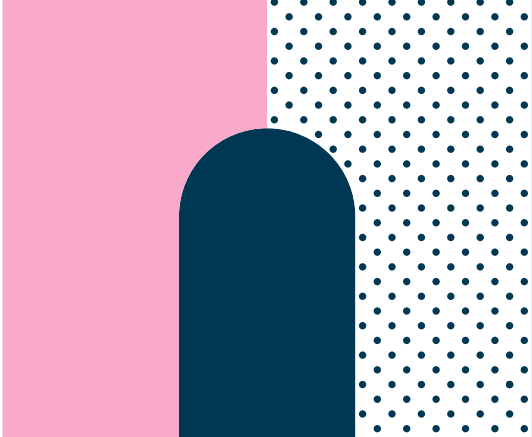
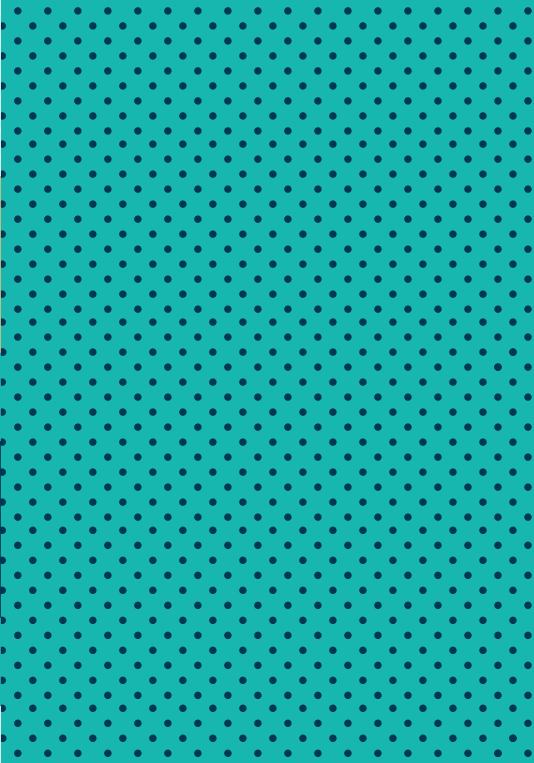



GENERAL INFORMATION



THE OLYMPIC GAMES: ESSENTIALS

PARIS AND FRANCE IN 2024

France is the world's top tourism destination with some 89 million visitors who flock here every year. Paris is a city unlike any other. It is overflowing with culture, history, and beauty. And whilst people travel to Paris to see the Louvre, the Eiffel Tower, or Notre-Dame, the real magic is found in the streets. Whilst Paris is a city with a strong cultural identity, it also houses people from all over the world who add their own culture and customs into the mix.

As you explore the streets of Paris, you might find yourself walking the hills of Montmartre in search of that perfect crêpe or meandering through Belleville, a Chinese neighbourhood with hip, young Parisians and elaborate street art. Across the river Seine, you might find yourself enjoying a “verre de vin” at a café in Saint-Germain-des-Prés or exploring the winding streets of the Latin Quarter.

France is also one of Europe's most diverse, gastronomic, and interesting countries to explore. Romantic hill towns and castles, meandering river valleys, and oceans of vineyards carpet this country's landscape.

France remains at the forefront of technology, architecture, fashion, and cuisine. A fascinating blend of natural and man-made beauty, France offers châteaux, never-ending coastlines, medieval cathedrals, Europe's highest mountain ranges, and museums showcasing cultural icons of the Western world.

THE 2024 OLYMPIC GAMES IN BRIEF

32

(28 + 4 additional sports)

19



Days of competition

47

Disciplines

758

Sessions

329

Medal events



10,500

Athletes



35



Competition venues

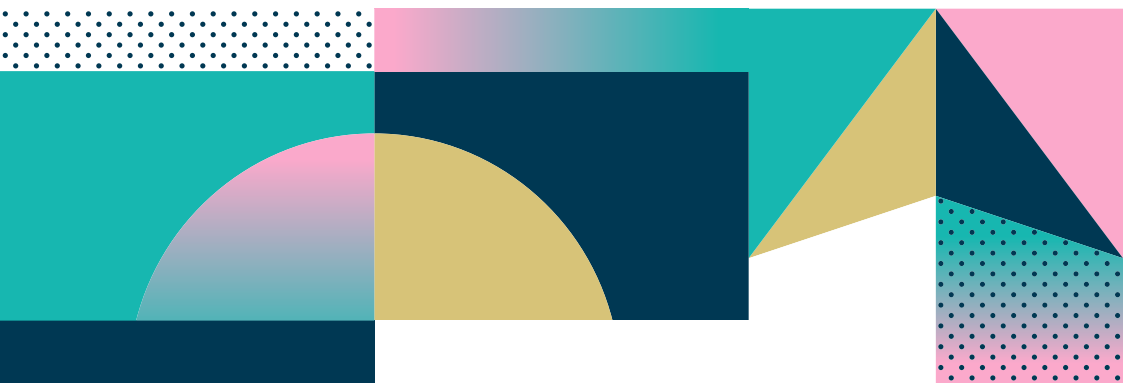



ACCREDITATION

OLYMPIC IDENTITY AND ACCREDITATION CARD (OIAC)

The Olympic Identity and Accreditation Card (OIAC) is the official Paris 2024 Olympic Games document that establishes the identity of its holder and their entitlements. In addition, the OIAC will provide accredited individuals with access to Olympic venues and other services during the Paris 2024 Olympic Games, according to their role.

To ensure the safety and security of all Games participants, they must pass a background check in order to receive an OIAC. The background check will be carried out by the relevant French Government agencies.

Unlike previous editions of the Olympic Games, the OIAC/PVC does not act as a visa waiver. For accredited participants who need a short-stay visa to enter the Schengen Area, Paris 2024 submits a visa request as part of the accreditation process. The final visa will be printed on the PVC and not on the participant's passport.

→ PRE-VALID CARD VALIDATION

The OIAC will grant access to Paris 2024 venues only once it has been validated after completion of the NOC's F-DRM. Validation must be completed in-person at a validation counter in any Paris 2024 accreditation facility.



Individuals arriving in France on international flights at Paris-Charles de Gaulle and Paris-Orly airports will be able to validate their PVCs at the airport from 15 July 2024, provided that their NOC's F-DRM has been completed. Individuals arriving via other ports of entry will have to go to the appropriate accreditation centre to finalise the procedure for validating their accreditation. Each participant will need to visit an accreditation facility in person to finalise the validation procedure. Individuals will need to bring their PVC and the valid ID provided to Paris 2024 during the accreditation application process.

ACCREDITATION CATEGORIES AND PRIVILEGES

All Games participants are provided with access only to the venues and zones that are required for them to complete the duties associated with their roles. The table below outlines the level of access granted to each category of participant.

→ CATEGORIES AND PRIVILEGE

CATEGORY	POPULATION	VENUE ACCESS	ZONE ACCESS	SEATING	TRANSPORT	VILLAGE
Aa	Athlete	Own discipline venue(s), OLV, MPC, IBC	2, R, BLUE	A Stand (at own discipline venues [1])	T-A	Yes
Ap	Alternate athlete	Own discipline venue(s), OLV	2, R, BLUE	No seating access Ticket necessary	T-A	No [2]
Ao	Coach, Medical personnel, Doctor, Physiotherapist, Technical personnel, Administrative personnel	Own sport venues or all venues where athletes participate, OLV	2, R, BLUE	A Stand (at own discipline venues [1])	T-A	PTO: Yes ATO: No [2]
Ao	NOC welfare officer	All venues in which the NOC has competing athletes, OLV	2, R, BLUE	A Stand	T-A	No [2]
Ao	Press attaché	Own discipline venue(s) or all venues where athletes participate, OLV, MPC, IBC	2, 4, R, BLUE MZ (athletes' side of the Press Mixed Zone)	A Stand (at own discipline venues or all venues where athletes participate)	T-A	PTO: Yes
Ao	Veterinarian	Equestrian venues only, OLV	2, R, BLUE	A Stand	T-A	Yes



CATEGORY	POPULATION	VENUE ACCESS	ZONE ACCESS	SEATING	TRANSPORT	VILLAGE
Ao	Groom	Equestrian venues only, OLV	2, R, BLUE	A Stand	T-A	No [2]
Ao	Caddy	Golf venue only, OLV	2, R, BLUE	A Stand	T-A	Yes
P	Training partner	Own training venue(s) only	2, White [3], [4], [5]	–	T-P	No
P	Personal Coaches/ Support Personnel	Own training venue(s) only. Access may be given to warm-up facilities in competition venues when possible	2, White [3], [4], [5]	–	T-P	No
NOC	Athlete chaperone	Athlete's discipline venue(s), OLV	2, R, White	A Stand	T-A	No [2]

- [1] Free ticket necessary for athletes' stand at other venues – please contact NOC Services for more information on procedures for obtaining tickets for different discipline spectating athletes (DDA).
- [2] NOCs can purchase the dining privileges (knife & fork symbol) to be added to the accreditation until the F-DRM.
- [3] For P accredited access, see conditions below.
- [4] For some sports where the venue is both a training and competition venue, P accredited will also have access to the competition venue(s) (see the “Competition” section in the guide).
- [5] P accredited for a specific list of sports (canoe [slalom and sprint], cycling track, football, gymnastics [artistic, rhythmic and trampoline], golf, rowing, sailing and surfing) will be allowed to obtain a Blue upgrade or SACD to access the FOP or specific areas.

→ ACCREDITATION PRIVILEGE CODES

The Accreditation Card Operating System assigns access privileges according to a privilege matrix that includes any function performing an official role at the Games. The privileges are based on accreditation zones and are printed on the OIAC along with the individual's personal information, function and responsible organisation. At sport venues the privileges give access to accreditation zones as described below:

ZONES	
WHITE	General circulation areas
RED	Operational areas, General circulation areas
BLUE	Field of play, Operational areas, General circulation areas
2	Athlete preparation areas
4	Press areas
5	Broadcast areas
R	Residential zone of the Olympic Village
MZ	Athletes' side of the Mixed Zone

SEATING	
A	Athletes' stand

TRANSPORT	
TA	Athletes/NOCs transport system
TP	Public transport systems



SPORTS / VENUES

CODE [1]	Competition venue(s) and training venue(s) for each discipline – white letters with black background
CODE [1]	Training venue(s) at any time and/or competition venue(s) on training days only – white letters with green background

[1] The code is represented by the three-letter acronym of the venue in question, or by ALL for access to all sites.

→ ACCREDITATION VALIDATION COUNTERS

VENUE	POPULATION	DATES 2024	VALIDATION	PRODUCTION	ISSUE RESOLUTION	HELP DESK
Airports CDG-Orly	Olympic Family	15 July (Full operation)	Yes	No	No	No
TPC Village	Athletes & team officials	12 July – 13 August (from pre- opening)	Yes	Yes	Yes	Yes
MPC / OFH Porte Maillot	Press & photographers IOC, dignitaries IF, and other Games Family	12 July – 11 August (from soft opening)	Yes	Yes	Yes	Yes
IBC	Right Holding Broadcasters	26 June - 11 August (from soft opening)	Yes	Yes	Yes	Yes
VAHO Venue Accreditation Help Office	All accredited populations	According to lockdown	Yes	No	Yes	No
VAHO+ Outside Île- de-France	All accredited populations	According to lockdown	Yes	Yes	Yes	Yes (limited)

VENUE	POPULATION	DATES 2024	VALIDATION	PRODUCTION	ISSUE RESOLUTION	HELP DESK
UAC Uniform and Accreditation Centre	All accredited populations	May 2024	Yes	Yes	Yes	Yes

→ LOST, STOLEN, DAMAGED ACCREDITATION CARDS

Lost and stolen accreditation cards should be reported immediately to the nearest accreditation centre or Venue Accreditation Help Office (VAHO). Participants will be required to complete a Lost/Stolen Accreditation Card form and present a valid form of identification.

Accreditation cards which are damaged in such a way that the photograph and/or the personal information is not legible or that the access control system is not able to read the card, should also be returned for replacement at any accreditation facility that provides accreditation card printing.

Please note that PVCs or OIACs cannot be reissued after the end of the operational period of Paris 2024 accreditation facilities.

→ ACCESS TO TRAINING VENUES - "P" ACCREDITATION

Training venues will be accessible only to holders of a valid accreditation. NOCs will be granted access to one or more training venues, according to the sport code(s) printed on their accreditation.

Specific passes for training venues will no longer exist for the Paris 2024 Games, but the requirements are integrated into "P" accreditation quotas.

The Olympic Village has eight training venues within its security perimeter for six sports (Studios and Gymnase Lallement): basketball, handball, breaking, fencing, modern pentathlon (fencing), weightlifting and wrestling. Seven of these venues are located in the existing cinema studios next to the Main Dining Hall, and they are accessible from the Village Plaza. The other training venue, Gymnase Aimé Lallement, is in the Village operational zone, next to Workforce Entry.

For access to training venues within the Olympic Village, "P" accredited persons for the relevant sports will be given an additional dedicated access code (not OLV) allowing them access to the training venues in the Olympic Village, only on the training day and according to the training schedule. It will not be possible to access





the Residential Zone from the Village Training Venues without “R” on the OIAC.

The maximum quota for “P” accredited personnel per venue per NOC, who are allowed access at any given time, is indicated in the Training section.

→ **SUPPLEMENTARY ACCESS CONTROL DEVICES (SACDS)**

A Supplementary Access Control Device (SACD) may be required to access specific areas of competition venues in line with sport-specific regulations. Specific areas within a venue, despite being within an accredited zone, can have additional restrictions and the OIAC itself may not grant access to these areas (e.g. the field of play, doping control stations). The SACD could take different forms such as an armband or an additional pass to be attached to the same lanyard as the OIAC.

The SACDs for each sport are detailed within the sport specific section of each Team Leaders’ Guide.

ANTI-DOPING

ANTI-DOPING PROGRAMME

The anti-doping programme for the Olympic Games is implemented by Paris 2024 under the responsibility of the International Testing Agency (ITA), to which the International Olympic Committee (IOC) has delegated certain responsibilities.

This programme is conducted in accordance with the anti-doping rules of the IOC (IOC ADR), and the World Anti-Doping Code. These rules are accompanied by a list of prohibitions, regulations governing the whereabouts of athletes and Therapeutic Use Exemptions (TUEs).

OPERATIONS DURING THE GAMES

Doping controls are carried out at competition venues, training sites, athletes' places of residence or any other location.

After doping controls have been carried out at Paris 2024 venues, athletes and officials may use the usual transport services (TA) to return to the Villages.

Outside TA service operating hours, Paris 2024 will ensure that a transport solution is available for their return.

As doping controls may take place at any time during the period of the Olympic Games, all athletes competing must provide complete whereabouts information.

The quantity and timing of tests, their nature and the identity of athletes selected for doping control are defined in accordance with the test distribution plans developed by the ITA.

More information on the antidoping programme at the Olympic Games is available in the Chef de Mission Guide and can be found in the "Publications section" of NOCnet (please contact your NOC if you do not have access to this).

TRANSPORTATION AFTER COMPLETING DOPING CONTROL ON THE DAY OF THE CLOSING CEREMONY

Doping control will also be conducted on the day of the Closing Ceremony. All athletes undergoing doping control must complete testing at their competition venue before travelling to the Closing Ceremony. After completing doping control, Paris 2024 will transport athletes to the Olympic Village. Athletes participating in the Closing Ceremony are requested to take a bus to the Olympic Stadium from the Olympic Village. Therefore, Paris 2024 recommends that all athletes who are competing on the day of the Closing Ceremony take with them to their competition venue all necessary items that may be required during the Closing Ceremony (such as their uniforms) as they may not be able to return to their accommodation in the Olympic Village prior to going to the ceremony.



ARRIVALS AND DEPARTURES

Paris 2024 will use several airports and train stations to welcome NOC delegations to the Olympic Games. The period of full arrival and departure operations will be effective 11 days before the Opening Ceremony and will end three days after the Closing Ceremony; 15 July - 14 August 2024.

The types of Port of Entry (POE) mentioned below are used by Paris 2024 to serve the official accommodation of the 2024 Olympic Games

PRIMARY PORTS OF ENTRY (PPOE).

Paris-Charles de Gaulle (CDG) and Paris-Orly (ORY) international airports will be the Primary Ports of Entry (PPOE) – Olympic Gateway – and will offer full arrival and departure services from 15 July - 14 August 2024. Services will be available in all terminals at the PPOE.

SECONDARY PORTS OF ENTRY (SPOE)

Secondary Ports of Entry (SPOE) will have limited services according to the information provided by NOCs in the ADS, and competition schedules.

Five SPOEs will be available during the Olympic Games:

- Fa'a'a International Airport (PPT), Papeete – Tahiti
- Paris-Gare de Lyon (train station), Paris
- Gare de Marseille Saint-Charles (train station), Marseille
- Paris-Gare du Nord (train station), Paris
- Marseille Provence Airport (MRS), Marseille

In addition, 20 Arrivals & Departures Service Points (AND SPs) will be available during the Olympic Games in co-host-city airports and train stations (see list in the Arrivals & Departures Guide). They will offer the same level of service as in SPOEs; but are activated on restricted dates depending on the competitions and information received via the ADS.

ACTIVATION PERIOD

CITIES	ACTIVATION PERIOD
Paris	15 July – 14 August 2024
Châteauroux	16 July – 8 August 2024
Marseille	16 July – 11 August 2024
Lille	16 July – 14 August 2024
Tahiti	16 July – 8 August 2024
Nice / Saint-Etienne	16 July – 3 August 2024
Bordeaux	16 July – 5 August 2024
Nantes	16 July – 11 August 2024
Lyon	16 July – 12 August 2024



ARRIVALS & DEPARTURES SERVICE

Primary port of entry	<ul style="list-style-type: none"> → Welcome and information desk at the exit of the baggage claim area → Accreditation validation desk → Accessibility support (airport service) → Transport service (based on ADS information and transport privilege) → Logistic trucks and handlers support (following the Transport Athlete) → TA coaches and logistics trucks for athletes and officials → Destination: Olympic Village, football hotels and incentive hotels → Facilitation at immigration control → Administrative assistance in the event of lost or delayed luggage/ sports equipment (communication with airlines and their sub-contractors)
Secondary port of entry	<ul style="list-style-type: none"> → Welcome and information desk at the exit of the baggage claim area, and in train station halls → Accessibility support (airport and SNCF services) → Transport service (based on ADS information and transport privileges) → TA coaches to official destinations → Logistic trucks and handlers support (following the Transport Athlete) → Administrative assistance in the event of lost or delayed luggage/ sports equipment (communication with airlines and their subcontractors, communication with SNCF services)
AND Service Points	<ul style="list-style-type: none"> → Welcome and information desk at the exit of the baggage claim area (only in Nice), and in train station halls. → Accessibility support (airport and SNCF services) → Transport service (based on ADS information and transport privileges) → Logistic trucks and handlers support (following the Transport Athlete) → Administrative assistance in the event of lost or delayed luggage/ sports equipment (communication with airlines and their subcontractors, communication with SNCF services)

Accreditation validation desks will be available in all terminals at Paris-Charles de Gaulle (CDG) and Paris-Orly (ORY) to allow NOCs to validate their PVCs once the NOC's F-DRM has been completed.

Accreditation validation desks will be open from 07:00-23:00 from 15 July - 11 August 2024. Validation desks will be located in secure zones of the terminals between immigration and the baggage claim area or in the baggage claim area depending on the terminals. Only PVC validation will be possible at CDG and ORY.

BAGGAGE AND ATHLETES' OVERSIZED SPORT EQUIPMENT

Upon arrival at the POE, it is the responsibility of the passenger and/or baggage manager to claim their own baggage, to check that all baggage has been delivered and accounted for and to check that baggage is not damaged.

All baggage destined for the Olympic Village, satellite Villages and football hotels will be transported either in the hold of the coaches or by the logistics trucks provided for this purpose.

Logistics staff (handlers) will be present at airports and train stations to assist delegations with the loading and unloading of baggage onto vehicles.

Logistics trucks will be available from the POE to official athlete accommodations, based on the information provided by NOCs on the ADS. Logistics support will be provided for the loading and unloading baggage of athletes' oversized sport equipment.

Vaulting poles, firearms and ammunition will be transferred from the POE directly to the competition or training venues. All other athletes sports equipment will be transferred from the POE to the Olympic Villages or football accommodation, the equipment will be temporarily stored at the Olympic Village and then delivered to the competition venue by the Paris 2024 logistics team.

For the transportation of firearms and ammunition, Paris 2024 strongly recommends using Paris-Charles de Gaulle (CDG) or Paris-Orly (ORY) international airports as Ports of Entry if NOCs wish to benefit from Paris 2024 transfer services. Services will start on 18 July 2024.

Firearms and ammunition will be transported to the competition venue located in Châteauroux (300km from CDG and 260km from ORY) by Paris 2024's official freight forwarder, according to a pre-established process as well as information provided by NOCs on the ADS.





At the airports, the delegations will be responsible for collecting their baggage and sports equipment from the baggage reclaim area and for transporting it to the loading area for the logistics vehicles.

Oversized sport equipment will be stored in one of the following locations:

- Village Residential Zone
- Competition venues for boats (canoe, rowing, sailing), firearms and ammunition
- Competition venue for bikes (track cycling)
- Training venues for vaulting poles

CEREMONIES

OPENING CEREMONY

The Paris 2024 Opening Ceremony will take place on the river Seine, in the heart of the city.

→ TIME

The Opening Ceremony will start at 19:30 on 26 July 2024 and will end at 23:45.

→ ATHLETES' PARADE

For the first time, the Opening Ceremony will not take place in a stadium but in the centre of Paris, on the “Olympic Seine”. Athletes will be the heart of the ceremony, which will start with the Athletes’ Parade. Throughout the Ceremony, athletes will be featured on boats alongside performers.

The parade will depart from Austerlitz Bridge. From the boats, athletes will enjoy spectacular views of some competition venues such as Place de la Concorde, Esplanade des Invalides, Grand Palais, and lastly Léna Bridge where they will disembark and make their way to Trocadéro and seats on the Léna Bridge for the ceremony finale.

The Opening Ceremony will consist of three main elements:

- Athletes' Parade: NOC delegations will travel six kilometres from east to west on the river Seine.
- Artistic show: There will be performances on river barges and bridges along the route of the Athletes' Parade.
- Protocol elements: Some protocol elements of the ceremony will take place at Trocadéro and Iéna Bridge.

→ PARTICIPATION TO THE CEREMONY

Only athletes by virtue of their accreditation and a limited number of team officials (Ac, Ao, Ap) with a marching pass may take part in the Athletes' Parade during the Opening Ceremony.

The marching pass quota has been validated by the IOC and is based on boat capacity with a minimum of three marching passes per delegation. The details of marching pass quota based on the number of athletes participating in the Olympic Games can be found in the Guide des Chefs de Mission.

Athletes and team officials who are not able to attend or do not wish to take part in the parade may stay at the Olympic Villages and follow the Ceremony from there.

→ DEPARTURES FROM OLYMPIC VILLAGE

Only athletes and team officials taking part in the Athletes' Parade will be able to participate in the Opening Ceremony. Shuttle buses will only be available from the Olympic Village, Paris, so those residing elsewhere must first go to the Olympic Village.

The buses will take parade participants to the boarding zone, which extends from the Nelson Mandela Bridge to Pont d'Austerlitz. Delegations will be grouped in buses according to their boat allocation. Please note that there will be no loading or parking areas for NOC vehicles on Pont d'Austerlitz. Athletes and officials joining the parade should start from the Olympic Village

The journey time is estimated at 45 minutes from the Olympic Village to the boat boarding zone. Ceremony uniforms will be checked by the IOC in the days prior to the Ceremony. NOCs are required to present their uniforms at the IOC offices in the NOC Services Centre to ensure they are compliant with Rule 50. There will be a further Rule 50 check prior to departure from the Olympic Village or prior to embarkation.





→ BOARDING

Athletes and team officials will board from the Nelson Mandela bridge and as far as Pont d'Austerlitz, in dedicated areas assigned to their group. Athletes will be dropped off close to their boats, with an average distance from bus to boarding of 110 metres. Paris 2024 staff will be available to guide and assist participants.

Water and snacks will be available along the way.

→ BOAT TRIPS

The fleet transporting athletes will comprise over 100 boats, ranging from the smallest boat measuring five metres to the largest measuring 90 metres long. The fleet mainly comprises traditional Parisian barges (wooden boats) and the famous "bateaux promenade" that are used for cruises on the Seine.

Different delegations will be grouped on the same boat, taking into account French protocol order and the capacity of the boat's exterior spaces to offer the best visibility and exposure for the athletes.

The largest boats will be able to accommodate a maximum of four delegations grouped together on board. The majority of the fleet will carry one or two delegations per boat.

→ DISEMBARKATION

The disembarkation zone from the Pont de Léna represents the end of the Athletes' Parade. The first delegations to start the parade will disembark to the west of the landing zone. In this way, the athletes will have time to reach Trocadéro while the rest of the boats dock as the parade progresses.

Following disembarkation, athletes will have two ways of getting to Trocadéro: on foot or by bus. The means of transport will be determined according to the disembarkation location.

Services, toilets and refreshments will be available along the way.

Upon disembarkation, athletes will also be able to return to the Village using early departure services. This arrangement is currently being studied and will be communicated later.

→ POST-CEREMONY DEPARTURES

The Opening Ceremony will end at 23:45. All athletes positioned on the Pont de Léna will be invited to join the bus pick-up area, located in the immediate vicinity of the Eiffel Tower, with an average distance of 500 metres from the Pont de Léna.

Athletes and team officials will be transported by bus back to the Olympic Village. Paris 2024 Food & Beverage and Village teams are working on extended Main Dining Hall services for those returning from the Opening Ceremony.

Further information will be provided later regarding athletes who are not accommodated at the Olympic Village or are coming from/returning to satellite Villages.

→ RISK MANAGEMENT, SECURITY, AND MEDICAL SERVICES

Paris 2024 is working closely with public authorities to ensure the safety of participants and access to medical services along the parade route.

Two systems will be in place:

→ A river system made up of a fleet of public authority boats that will sail during the parade alongside the fleet of boats hosting the delegations. In addition, Paris 2024 medical teams will set up a nautical device along the route.

→ A ground system:

- Security: all embarkation areas and boats will be inspected by the public authorities before delegations arrive in the area.
- Access to medical care: medical teams will be available in the embarkation and disembarkation zones, specifically for NOC delegations. A dedicated medical facility will also be in place at Trocadéro.

CLOSING CEREMONY

The Closing Ceremony will take place at Stade de France, the nation's largest stadium.

The ceremony will start at 21:00 and finish at 23:15. Please note that timings are subject to change. Updates will be provided to NOCs as plans are confirmed.



The Ceremony will be composed of four main elements (the elements may be alternated between protocol and artistic sequences):

- Flag bearers' parade, in protocol order
- Athletes' parade, in masse without protocol order, symbolising unity between countries
- Protocols elements: official speeches, handover ceremony, extinguishing of the flame to mark the end of the Games, etc.
- Artistic concepts: a series of artistic shows or tableaux, in which Thomas Jolly, the artistic director of the Ceremonies, will express his innovative staging approach, offering an unforgettable show.

→ **TRANSPORT**

TRANSPORT FROM THE OLYMPIC VILLAGE TO THE STADE DE FRANCE

Gathered at the Transport Mall in the Village, the athletes will transfer by bus to the holding area at the Annexe Stadium of the Stade de France. Transfer time by bus is estimated at eight minutes.

A continuous rotation of buses (with a capacity of 80 seats) will be set up between the Olympic Village and the Annexe Stadium. Delegations will be accompanied by NOC assistants and volunteers throughout their journey. Further details will be provided during the Chefs de Mission meeting on the day before the Closing Ceremony.

Please note that participants in the Closing Ceremony are not allowed to bring bags or luggage.

TRANSPORT FROM COMPETITION VENUES TO THE STADE DE FRANCE

For athletes competing on the day of the Closing Ceremony, transport will be arranged in accordance with the competition schedule.

Due to the tight schedule between the end of competition and the Closing Ceremony, direct transport to the ceremony will be provided for basketball and handball athletes. Competing athletes will be transported by their team buses while separate TA buses will be provided to Same Discipline Athletes (SDA). Athletes participating in the Closing Ceremony must load their own baggage on to the bus going to the Olympic Village. Buses will first go to the Olympic Village to drop off the baggage, as well as Team officials or athletes not participating in the ceremony. A late departure TA bus will be

provided for athletes who attend press conferences after competition. Athletes who undergo anti-doping tests may take this bus if they wish to participate in the ceremony as long as samples are completed before departure.

→ FOOD AND BEVERAGES

Snacks and water will be provided during the athletes' journey from the start of the Olympic Village until the athletes and team officials return after the Closing Ceremony. Paris 2024 Food & Beverage and Village teams are working on extended Main Dining Hall services for those returning from the Closing Ceremony.

VICTORY CEREMONIES

In principle, Victory Ceremonies will take place at the competition venue for each sport and discipline, with the exception of Victory Ceremonies for the men's and women's marathon and race walk that will be held in the Stade de France. For women's marathon, the Victory Ceremony will be celebrated during the Closing Ceremony. During the ceremonies, the medal and a gift will be presented to gold, silver and bronze medallists. The flags of the countries/territories of the medallists will be raised and the national anthem of the country/territory of the gold medallist will be played. Victory Ceremonies will be conducted in French and English.

During the Victory Ceremonies, the medallists' accreditation must be temporarily handed over to Paris 2024 staff or held out of sight. No participant should carry flags, mascots, or other personal items such as mobile phones, water bottles or cameras. Medallists must also comply with Rule 50 of the Olympic Charter and the Guidelines on Athlete Expression.

Upon completion of the photo opportunity after the victory ceremony, each athlete will be required to pass through the mixed zone, unless indicated by the athlete escorts and the Paris 2024 sport manager.

During the Victory Ceremony, the athletes are required to stay in line of sight of the doping control team at all times. Therefore, it is imperative that athletes do not deviate from the prescribed routes outlined in the briefing.



→ MEDALS AND DIPLOMAS

Medals and diplomas will be awarded in each event in accordance with the IOC Olympic Charter (Rule 56: Victory, Medal and Diploma Ceremonies) and the IOC Protocol Guide (Article 5.4).

- First place: a gold (silver gilt) medal, a diploma, an Olympic medallist's pin and a medal box.
- Second place: a silver medal, a diploma, an Olympic medallist's pin and a medal box.
- Third place: a bronze medal, a diploma, an Olympic medallist's pin and a medal box.
- Fourth, fifth, sixth, seventh and eighth places: a diploma.

Medal boxes, medallist pins and victory diplomas (for athletes ranked first to eighth) will be distributed in the NOC Services Centre at the Olympic Village. Satellite Village information will be confirmed later.

CHAMPIONS PARK

In the majestic setting of Trocadéro, the Champions Park (Le Parc des Champions) will offer medallists a unique experience in the history of the summer Olympic Games: an iconic place to celebrate their performance and their medals.

At the end of each day, medallists from the previous day will be invited to gather and celebrate their victories in an unforgettable setting, in front of the Eiffel Tower and 15,000 sports fans. A live broadcast of competitions and main finals will follow the celebrations.

The Champions Park will be open for ten days of celebrations, from 29 July - 10 August 2024, except 2-4 August 2024 when the Champions' Park will be closed.

Each athlete's celebration at Champions Park is planned to take place the day after their respective Victory Ceremony.

On the day of the Victory Ceremony, NOCs will be requested to confirm athlete attendance at the Champions' Park the following day, to allow for proper planning.

Medallists will have the opportunity to celebrate their victories with their family and friends (limited number) in a dedicated area at the Palais de Chaillot, before and after meeting the public.

After celebrating their medals, athletes will be able to proceed to the Mixed Zone if they wish to do so, or to enjoy the live site and/or restricted area in Palais de Chaillot.

Athletes can expect to spend at least one hour at the venue.

ATHLETE TRANSPORTATION SERVICES

Paris 2024 will organise dedicated transport services between the Olympic Village and Trocadéro, on days when they will be celebrating at the Champions' Park.

It will also be possible for athletes to come to Trocadero by other means of transport.

Regarding athletes competing in Châteauroux and Marseille, studies are being conducted on transport to/from Paris and/or the Olympic Village to allow athletes from these sports to be celebrated as well. Note that additional beds will not be provided at the Olympic Village for athletes travelling from the satellite Villages to go to the Champion's Park.

SCHEDULE OF CELEBRATIONS

The detailed schedule of celebrations will be defined according to other activities at Trocadéro (including the Opening Ceremony, race walk and road cycling events).

Please note that:

→ Medallists on D1 (27 July) will be celebrated on D3 (29 July)

→ Medallists on D6 (1 August), D7 (2 August) and D8 (3 August) will be celebrated on D10 (5 August).

Surfing medallists who are travelling to Paris after their competition will have the opportunity to celebrate with their fans at the Champions Park, between 5 and 10 August.

CHAMPIONS PARK INFORMATION DESK

A Champions Park desk will be available in the NOC Services Centre at the Olympic Village to answer operational questions from NOCs.



ENVIRONMENTAL RESPONSIBILITY

Paris 2024 has been committed to proposing a different model for the Games, one that is more understated and just as spectacular, and it is mobilising all its energies to achieve this. Paris 2024 is working at all levels of the organisation to reduce its environmental and climate impact. By developing and testing more responsible solutions across all aspects of the organisation, Paris 2024 also hopes to inspire and leave a legacy for more responsible sport.

Paris 2024 is committed to halving its carbon emissions compared with the average for previous editions of the Games (London 2012, Rio 2016).

To achieve this, Paris 2024 is taking action at every level. By relying on 95% existing or temporary infrastructure, by offering twice as much plant-based food, by halving the amount of single-use plastic in catering, by finding a second-life solution for 100% of the temporary infrastructure and furniture on the Games sites, by connecting the venues to the public electricity distribution network to avoid the use of generators and by supplying the venues with 100% renewable electricity.

You can discover the rest of the commitments and actions for more responsible Games on our website.

RECOMMENDATIONS

The success of more responsible Games is everyone's responsibility. At all the venues, you have the opportunity to act at your own level and help Paris 2024 achieve its objectives for Games that everyone can be proud of. That's why Paris 2024 encourages you to adopt a few eco-reflexes:

- Using reusable water bottles and water fountains at the Olympic Village to reduce plastic waste.
- Using the waste sorting system to reduce the volume of waste that is sent to landfill sites.
- Promoting responsible food options and reducing food waste.
- Ensuring the responsible management of water and energy resources.
- Preserving sites and their environment, and respecting equipment to encourage their second life.

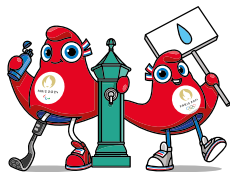

USE YOUR REUSABLE BOTTLE AND THE WATER FOUNTAINS

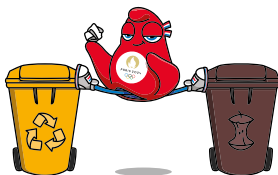

AVOID FOOD WASTE AND SORT YOUR WASTE

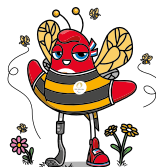

RESPECT THE VENUES AND BIODIVERSITY



EAT MORE RESPONSIBLY

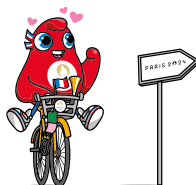

TRAVEL WITH A LOW CARBON FOOTPRINT

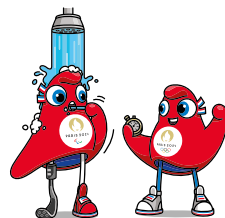

SAVE WATER AND ENERGY RESOURCES



MEDICAL SERVICES

Public health services, including disease surveillance, communicable disease control, food and water quality control and air quality monitoring will be in place throughout France during the Games.

A basic summary of medical services at the Games is given below. Full details will be provided in the Healthcare Guide which will be distributed to NOCs by Paris 2024 early 2024.

OLYMPIC VILLAGE POLYCLINIC

The three-storey Danhier Institute, which was renovated in 2021, is a podiatrist and osteopathy school of 3,262 m². The institute, which is located in the south-east of the Olympic Village, will be the Polyclinic for the Paris 2024 Olympic Games. All the necessary medical services will be provided to athletes and NOC teams officials from 18 July to 13 August 2024. Emergency services will be available 24 hours a day, and other services from 07:00-23:00.

POLYCLINIC SERVICES WILL INCLUDE:

- Emergency services
- Imaging, with two MRIs, X-ray and ultrasound
- Laboratory services
- Mental health department
- Pharmacy
- Physical therapy, including ice baths
- Specialised consultation:
 - Orthopaedics and Sports Medicine
 - Cardiology
 - Gynaecology
 - Podiatry
 - Supply of orthopaedic products (insoles, supports and orthoses, medical and sport compressions)
 - Ophthalmology
 - Dentistry, including the provision of mouth guards for athletes in need
 - Therapeutic Use Exemption (TUE) office

MEDICAL SERVICES AT SATELLITE OLYMPIC VILLAGES

The medical services at satellite Villages will be available as follows:

SATELLITE VILLAGE	DATES OF OPERATION	MEDICAL RESOURCES	OPENING HOURS
Châteauroux	19 July - 7 August 2024	Emergency Doctor	20:00 – 08:00 (at night)
		Physiotherapist	08:00 – 22:00
		Osteopath	11:00 – 19:00
Lille Métropole	19 July - 12 August 2024	Emergency Doctor	20:00 – 08:00 (at night)
		Sports Doctor	08:00 – 22:00
		Physiotherapist	07:00 – 23:00
		Osteopath	08:00 – 17:00
Marseille	20 July - 12 August 2024	Emergency Doctor	20:00 – 08:00 (at night)
		Osteopath	07:30 – 10:30
Tahiti	20 July - 6 August 2024	Emergency Doctor	24 hours a day
		Nurse	24 hours a day

MEDICAL SERVICES AT VENUES

→ ATHLETE MEDICAL SERVICES AT COMPETITION VENUES

At least one dedicated athlete medical station will be available at all competition venues. Each medical station will provide medical such as first aid, emergency care, sports medicine to athletes and team officials.

At most venues there will be an ambulance on site for the evacuation of athletes if needed. If not directly on site, ambulances will be available nearby.



→ **FIELD-OF-PLAY RESPONSE**

Field-of-Play (FOP) teams will provide first aid and emergency care to athletes and team officials on the FOP should such services be required. If necessary, the patient will be taken from the FOP and transported to the athlete medical station, Olympic Village Polyclinic, or a designated Games hospital as appropriate. The order of response on the FOP and any decision-making will differ according to the sport and the rules of the respective IF.

→ **MEDICAL SERVICES AT TRAINING VENUES**

Medical services at training venues vary depending on the venue size, the number of sports training there and the IFs regulations. Details are indicated in the “Training” section and can be found in the Paris 2024 Medical Guide.

DESIGNATED GAMES HOSPITALS

If the necessary medical services cannot be provided at the Olympic Village Polyclinic or at the venue medical station, the athlete or team official will be transferred to designated Games hospitals in Paris or the co-host city.

Any patient suffering from a life-threatening condition at any of the venue zones will be taken to the nearest hospital.

The following public hospital has been designated as the official hospital for athletes and NOC team officials during the Paris 2024 Olympic Games:

**GHU AP-HP Nord-Université Paris Cité
(site hospitalier Bichat – Claude Bernard)
46 rue Henri Huchard, 75018 Paris**

In co-host cities, the designated hospitals are the following:

SATELLITE OLV	HOSPITAL*
Châteauroux	Centre hospitalier de Châteauroux 216 avenue de Verdun, 36000 Châteauroux
Lille	CHRU de Lille rue Emile Laine, 59000 Lille
Marseille	AP-HM hôpital de la Timone 264 rue Saint-Pierre, 13385 Marseille
Tahiti	Centre hospitalier de Polynésie française Avenue du Général de Gaulle, 98713 Papeete

OLYMPIC VIDEO PLAYER (OVP)



Users will be able to view live streaming of all events covered live by OBS, and sport sessions will then be available in full, on-demand. English language commentary is available for selected sessions. All live content is subsequently available as Video-on-Demand replays for the duration of the Games.

OVP will be available for use on a laptop with Wi-Fi Internet connection at <https://olympics.com/en/olympic-channel>.

OLYMPIC VILLAGES AND ACCOMMODATION

During the Paris 2024 Olympic Games, the Olympic Villages will accommodate 14,200 athletes and team officials. The main Olympic Village is located north of Paris and will be completed by satellite Olympic Villages in Châteauroux, Lille Métropole, Marseille and Tahiti, as well as grooms' accommodation and football accommodation.

OLYMPIC VILLAGES DATES OF OPERATION

VILLAGE	PRE-OPENING	OPENING	CLOSING
Olympic Village	12 July at 08:00	18 July at 08:00	13 August at 18:00
Olympic Village Châteauroux	16 July at 08:00	19 July at 08:00	7 August at 18:00
Olympic Village Lille Métropole	16 July at 08:00	19 July at 08:00	12 August at 18:00
Olympic Village Marseille	17 July at 08:00	20 July at 08:00	12 August at 18:00
Olympic Village Tahiti	17 July at 08:00	20 July at 08:00	6 August at 18:00
Grooms Village	24 July at 08:00	11 August at 18:00	24 July at 08:00

All the information about the Olympic Villages can be found in the different Olympic Village Guides and the Chefs de Mission Games Time Guides, available on NOCnet.

SECURITY

In accordance with its letter of guarantee and the IOC's Host City Contract, the French State is responsible for the safety and security of the Paris 2024 Olympic Games.

The government will coordinate all security matters as well as emergency services, whilst Paris 2024 is responsible for the design, implementation, and execution of security measures at Paris 2024 competition and non-competition venues.

Paris 2024 has partnered with national security agencies to integrate the most effective security arrangements within venues and other official sites.

SECURITY AT VENUES

→ VENUE INSPECTION AND LOCKDOWN

The Olympic Villages, as well as the other accommodations and all competition and training venues will undergo a security inspection by specialist government departments and a lockdown period prior to the Games.

During the lockdown period, all security and safety procedures will be implemented, and access controls will be activated with the support of technology measures. However, please note that French legislation does not allow facial recognition. During this period, no person, vehicle, or equipment may enter the venues without accreditation (or other appropriate access devices) and without passing the appropriate security checks.

After the accreditation check, people wishing to access venues will be subject to a personal and property inspection. Personal and baggage inspections for people whose age, mobility or medical reasons do not allow them to undergo the generic procedure are subject to an adapted procedure that takes better account of their specific needs.

→ OLYMPIC VILLAGES

Access to the Olympic Village will be based on validated accreditation or other appropriate access devices. Access will be secured by Pedestrian Screening Areas (PSA) and Vehicle Screening Areas (VSA) to ensure that no prohibited items are brought in, and that each person has a valid accreditation.

The main principles of Olympic Village security are as follows:



- A perimeter entirely enclosed by video-monitored security barriers and equipped with anti-intrusion systems.
- A security inspection conducted by specialised government services prior to opening.
- Village surveillance and access control conducted by private security companies.
- Systematic pedestrian and vehicle control measures.
- Permanent state surveillance of the area surrounding the Olympic Villages with specialised intervention resources.

At competition venues, areas will be restricted to athletes and team officials. These areas will be secured by accreditation access control points.

→ FOOTBALL HOTELS

After the security inspection, a visual check of accreditation will be activated for the Paris 2024 exclusive zones: the check will be carried out in the exclusive zones as well as in the “drop-off/pick-up” zone.

Security checks will be carried out by magnetometer. In addition, the seals on the athletes’ buses will be checked. If the seals are broken, a new check will be carried out, and the doors will be locked and sealed after loading.

Securing the drop-off/pick-up area involves surveillance of this area with a protective device during loading and unloading if the hotel is not exclusive.

Human and video surveillance will be provided at all times, including lobby and Paris 2024 fleet.

→ TRAINING VENUES

After the State services have locked down the venues, access to training venues will be granted on presentation of a Paris 2024 accreditation that allows access to those venues.

A visual accreditation check will be carried out during pedestrian access, as well as a security check (bag opening, magnetometer).

Transport for Athletes (TA) services must be equipped with a Vehicle Access and/or Parking Permit (VAPP) allowing them access to venues. In addition, a seal control will be carried out at the vehicle access point. For other authorised vehicles, an additional control of accreditation of the persons in the vehicles will be carried out. Without this, access will not be granted.

SECURITY OF TRANSFER AND TRANSPORT OPERATIONS

In Île-de-France, there will be a surveillance system for Olympic routes under the supervision of the Préfecture de Police.

A “bubble to bubble” system will operate from the Village Transport Mall to/from training and competition venues. TA vehicles will travel from one secure area to another using Olympic routes. Athletes and team officials will be allowed to remain inside the vehicle. The process of checking the external parts of the vehicles will be quick. However, these vehicles will have to stop at the Vehicle Screening Area (VSA) and there may be a queue for a few minutes before the inspection.

Athletes and team officials returning from training/competition venues will need to exit the TA vehicle at the Village Transport Mall and enter the Residential Zone through the Pedestrian Screening Area (PSA).

All NOC vehicles with an appropriate VAPP will go through the usual security processes at the VSA. Passengers will also be screened individually.

PROHIBITED OR RESTRICTED ITEMS POLICY

→ PROHIBITED ITEMS

These items are strictly forbidden in the Paris 2024 venues.

AT COMPETITION VENUES

- **Firearms and/or ammunition not used for Games competitions.**
- **Replica weapons:** airsoft firearms, replica weapons and/or reproductions that could cast doubt on the owner’s intention.
- **Weapons “of opportunity”:** selfie sticks, everyday blades (such as multi-tools, scissors, razors etc.) that can malevolently be used as a weapon to inflict harm.
- **Explosives, flammable substances, and pyrotechnic devices:** explosive devices, improvised explosive devices, gunpowder, smoke bombs, smoke, flares, fireworks, objects resembling explosive devices, ignition devices.
- **Dangerous substances, doping products, and illegal narcotics:** items likely to infringe the law regulating toxic and noxious substances, narcotics and stimulants or other illegal drugs in France, Europe, and other parts of the world, items corresponding to dangerous materials under French legislation, tear gas, pressurised containers, items corresponding to dangerous materials,
- **Alcoholic beverages.**





- **Glass containers, cans, and tins.**
- **Wireless equipment not authorised without a TAG from French spectrum agency (ANFR):** radios, microphones, broadcasting cameras, drones, satellite links, wireless 4G routers, jamming or scanning equipment, radio scanners.
- **Political, religious, vulgar messaging, or trademarks:** advertising materials, signs, banners, etc. that include a religious or political message, or are deemed contrary to public order. Ropes, carboards, posters, and other items that can be used for demonstrations in the venues,
- **Personal mobility devices, whether electric or not:** bicycles, scooters, rollerblades, skates, gyropods, hoverboards, etc.
- **Objects producing excessive noise:** megaphones, vuvuzelas, air horns.
- **Laser pointers.**

IN OLYMPIC VILLAGES

- **Firearms and/or ammunition not used for Games competitions.**
- **Replica weapons:** airsoft firearms, replica weapons and/or reproductions that could cast doubt on the owner's intention.
- **Explosives, flammable substances, and pyrotechnic devices:** explosive devices, improvised explosive devices, gunpowder, smoke bombs, smoke, flares, fireworks, objects resembling explosive devices, ignition devices.
- **Dangerous substances, doping products, and illegal narcotics:** items likely to infringe the law regulating toxic and noxious substances, narcotics and stimulants or other illegal drugs in France, Europe, and other parts of the world, items corresponding to dangerous materials under French legislation, tear gas, pressurised containers, items corresponding to dangerous materials,
- **Wireless equipment not authorised without a TAG from French spectrum agency (ANFR):** radios, microphones, broadcasting cameras, drones, satellite links, wireless 4G routers, jamming or scanning equipment, radio scanner.
- **Political, religious, vulgar messaging, or trademarks:** advertising materials, signs, banners, etc. that include a religious or political message, or are deemed contrary to public order. Ropes, carboards, posters, and other items that can be used for demonstrations in the venues,

→ RESTRICTED ITEMS

These items are authorised at venues but restricted in quantity and/or nature.

AT COMPETITION VENUES

- **Weapons of opportunity:** only walking aids are authorised,
- **Flammable substances:** only portable oxygen cylinders for medical use are allowed,
- **Containers:** plastic bottles, plastic or metallic flasks/gourd are allowed,
- **Luggage:** large sports bags and large pieces of luggage are permitted,
- **Animals:** only service dogs are allowed,
- **Flags:** only flags of countries and territories participating in the Games are allowed, without rigid flagpoles, and without size restrictions for athletes at competition venues.

IN OLYMPIC VILLAGES

- **Weapons of opportunity:** walking aids, everyday blades (such as multi-tools, scissors, razors etc.) that are allowed in planes, that can malevolently be used as a weapon to inflict harm.
- **Flammable substances:** only portable oxygen cylinders for medical use are allowed,
- **Animals:** only service dogs are allowed,
- **Sprays and aerosols:** sprays and aerosols used for daily hygiene such as deodorants are allowed,
- **Objects producing excessive noise:** personal musical instruments and music speakers are allowed,
- **Flags:** only flags of countries and territories participating in the Games are allowed, without rigid poles. No maximum size for athletes at Villages.

OBJECTS CONSIDERED AS “TOOLS OF THE TRADE”

Objects authorised at venues only if they are required to carry out professional activities for certain stakeholders.

AT COMPETITION VENUES

- **Weapon of opportunity:** tools such as hammers, wrenches, saws, screwdrivers, etc. needed to maintain sports equipment and personal mobility aids for people with reduced mobility, but that can malevolently be used as a weapon to inflict harm,





- **Personal mobility devices:** bicycles and other personal means of transport required for on-site competitions,
- **Sprays and aerosols:** sprays and aerosols required for sports and for the treatment of athletes,
- **Photography equipment:** camera lenses larger than 20cm are authorised.
- **Camera equipment:** all equipment used to take photos and videos to analyse athlete performance.
- **Medical equipment for the treatment of athletes.**

IN OLYMPIC VILLAGES

- **Weapon of opportunity:** tools such as hammers, wrenches, saws, screwdrivers, etc. necessary to help people settle at villages and the maintenance of sports equipment.
- **Laser pointers** to be used in meetings
- **Medical equipment for the treatment of athletes.**

At the F-DRM, the Chefs de Mission will receive stickers to be applied on tools of trade that have been registered in advance via Paris 2024 NOC services. The Chef de Mission will be responsible to distribute the stickers to all the delegation.

Please note that for security reasons, the use of drones is strictly forbidden at all competition and non-competition venues of the Olympic Games.

EMERGENCY SERVICES

→ EMERGENCY NUMBERS OUTSIDE PARIS 2024 VENUES:

- European emergency number: 112
- Emergency Medical Services (SAMU): 15
- Police: 17
- Fire brigade: 18

Paris 2024 recommends that NOCs do not programme emergency service numbers into mobile phones as speed dial functions can lead to accidental calls to the emergency services.

→ EMERGENCY NUMBERS THAT SHOULD BE USED AT PARIS 2024 VENUES

Olympic Village: +33 9 20 24 48 16

SPORT INFORMATION CENTRE

The Sport Information Centre (SIC) will be located in the Halle Maxwell in the Olympic Village. Each competition venue and satellite Village will also have a Sport Information Desk (SID) where NOCs can go for venue and sport-specific information.

Venue SIDs will work closely with the Sport Information Centre (SIC) at the Olympic Village.

A variety of services and information will be available at the SIC/SID, including:

- sport-related information, sports publications, event announcements, schedules, results, etc.
- training schedules
- transport, food and beverage services information
- weather information

A reception area and reception desks divided by groups of sports (one desk for several sports) will be available in the SIC to answer specific questions from NOC team officials.

Athletes will not be allowed to access the SIC. Only duly accredited NOC team officials will be allowed to enter the SIC.

A sewing room and Spectrum office (radio spectrum testing and tagging room) will also be available at the SIC. In the Spectrum Office, the team will examine wireless equipment to ensure that it meets the specifications outlined in the radio frequency authorisation certificate.

	LOCATION	DATES	TIME
SIC Olympic Village	Halle Maxwell	18 July – 11 August	07:00 – 21:00*
Sport information desks (SID)	Competition venues	See “Services” in the Competition venue section	

*Except on 26 July and 11 August, where the SIC will close at 17:00 for the Opening and Closing Ceremonies.



MYINFO

myInfo (also formerly known as Info+) is an official sports reporting and information service platform delivered by the IOC and OBS, with development support from the organising committee. The service is designed to help with the official media coverage during the Olympic Games. Accredited NOC personnel will have access where needed and for unaccredited members of an NOC, additional access tokens can be requested through the Rate Card (subject to availability).

Please note that most of the information provided on myInfo will also be available on the Paris 2024 Games time website and application.

myInfo will be available as of 15 July 2024, and remain open until 14 August.

CONTENT	DETAILS
Background	Historical data, statistics, competition formats and rules, qualification criteria and venue descriptions
Biographies	Athlete biographies and team, coach, referee, umpire, judge and NOC profiles
Ceremonies	Details about Opening Ceremony, Closing Ceremony and medal ceremonies, including timings and participants
Games News	Flash quotes, press conference highlights, sport previews, news articles, statistic-driven reports, media communications and IOC news
Medals	Medal standings by sport, overall medal standings, and medallists by day, sport and events
Records	World and Olympic records, including current records, record holders and new/equalled records
Results	Competition results viewable by sport, date and NOC. Includes entry lists, start lists, results and additional sport-specific reports
Schedules	Competition and non-competition schedules, including press conferences, IOC activities and Cultural Olympiad

myInfo is available for users with an internet connection and login account (username and password) from all Paris 2024 venues, as well as remotely. myInfo provides the following features:

- customisation (ability for users to create their own notification overview by selecting only those sports and events of interest to them)
- news/events alerts via email
- hyperlinks to other websites, such as those of the IOC and IFs
- downloadable results books and competition reports
- copy and paste functionality

NOCs will have a free access to myInfo on available laptops at the SIC.

TECHNICAL FILMING AT VENUES

Technical filming at competition venues is treated on a sport-by-sport and venue-by-venue basis.

For those sports requiring competition footage for the IF and/or NOCs, a match copy service will be provided at the end of each session as per the individual International Federation requirements. Apart from exceptional cases where the footage derives from the video adjudication system, no USB sticks will be provided, but the video will be available for download from a dedicated online platform.

A link/QR code to access the web platform will be shared by the SPT team at the Sport Information Desk within the competition venue. The number of downloads per NOC will be strictly limited and only available for the respective sport. Download of the footage will only be available at the competition venue or in the Olympic Village.

Three Sport Viewing Rooms are available inside the Bastille Services Centre. Each of them has a 30-person capacity.

Inside these rooms, a device will allow NOCs to use the Content+ service provided by OBS and display competition footage for analysis purposes on the TV available in each room.



TECHNOLOGY

The IOC, supported by Samsung and Paris 2024, is pleased to offer a cutting-edge Samsung smartphone to each athlete participating in the Games. All “Aa” athletes (including “Ap”) will receive their Samsung smartphone at the Olympic Village. These smartphones will come with a SIM card.

Athletes are encouraged to use their Samsung smartphones during the Olympic Games, as they will be a central hub for both general and useful information and communication.

TICKETING AND ACCREDITED SEATING

GAMES-TIME TICKET SALES

At Games time, available tickets may only be purchased through the CTP.

COMPLIMENTARY SPORT TICKETS

→ SAME DISCIPLINE ATHLETES (SDA)

Athletes and officials may access the athletes’ stand during competition for their own discipline(s) without a ticket, upon presentation of their Olympic Identity and Accreditation Card (OIAC).

→ DIFFERENT DISCIPLINE ATHLETES (DDA)

To enhance the athlete experience, Paris 2024 will offer Different Discipline Athlete (DDA) tickets. The DDA ticketing programme allows athletes to attend competitions of disciplines other than their own free of charge.

Paris 2024 will offer one free ticket per athlete per day for a sport or discipline in which they do not compete. DDA have access through general public flows, and no transport services will be provided. DDA ticket holders need to take public transport to competition venues.

DDA tickets must be requested directly by athletes using a special link that will be provided by Paris 2024 to the Chefs de Mission, following the pre-DRMs.

→ **ATHLETES' FRIENDS & FAMILY (AF&F)**

Paris 2024 will guarantee two tickets for purchase per competing athlete per session, except for athletics (race walk), cycling road, shooting, and swimming. For these four sports/disciplines, Paris 2024 will guarantee one ticket for purchase per competing athlete per session.

AF&F ticket quota information and a list of sessions for which only one ticket is available per athlete per session, can be found on the CTP. AF&F tickets are not available for the Opening and Closing Ceremonies.

More information on the AF&F ticket programme and booking procedures is available in the Chefs de Mission Guide.

→ **TICKET TOUTING**

Tickets for the Paris 2024 Olympic Games are only on sale on the official ticketing website for future spectators from all over the world. No other sales platform is authorised to sell tickets. By buying tickets or hospitality packages outside official channels, the buyer runs the risk that tickets or packages are not delivered to them, or that access to the sports venues will be denied to them by the Paris 2024 Organising Committee in accordance with the ticketing general terms and conditions. In addition, all buyers and/or sellers are informed that the unauthorised sale or resale of tickets outside of the official channels, constitutes an offense under French law, in particular, an offense sanctionable under article 313-6-2 of the French criminal code.

TRANSPORT

Paris 2024 aims to provide effective, reliable, secure and efficient transport services for athletes, team officials and members of the Olympic Family. A summary of transport services is given below, all details are available in the NOC Transport Guide.

The transport services will consist of:

- Transport for Athletes (TA)
- Intercity travel
- Public transport (TP)
- Transport Connect (TC)



TA TRAINING AND COMPETITION SERVICES

The Transport for Athletes (TA) system will provide “bubble-to-bubble” transport services for athletes, NOC team officials (Aa, Ac, Ao and Ap), and their personal equipment, from 18 July until 13 August 2024 for competition and training.

The TA system comprises the following services:

- Arrivals and departures from/to Ports of Entry to/from the Olympic Village.
- Arrivals and departures to/from Ports of Entry in co-host cities to/from satellites Villages and official hotels.
- Transport between the Olympic Villages and official competition and training venues.
- Opening and Closing Ceremony services.

TA services vary depending on whether sports are individual sports or team sports. All activation dates and frequencies have been reviewed together with the International Federations (IFs) and the IOC to ensure they meet the needs of each sport. Schedule information is provided in the NOC Transport Guide.

→ INDIVIDUAL SPORTS

Transport services for individual sports between the Olympic Villages or hotels and the competition or training venues will be provided for athletes and team officials, according to the competition and training schedule as well as needs of the sport/discipline.

All the TA lines operating for individual sports are said to be shared, meaning that there are no dedicated buses for delegations, all athletes are moving together regardless of the country of origin.

→ TEAM SPORTS

To ensure that all team members can travel together, dedicated coach transfers will be provided for athletes and NOC team officials. Services will be provided between the Olympic Villages or football hotels and competition/training venues. Note that buses will not be allowed to stop anywhere en route to venues.

Services will start on the opening days of the Olympic Villages according to the needs of teams and the relevant sport.

Team sport bus schedules will be provided by the Sport Information Centre.

The booking and change request process is the following:

- For a training transfer: updates on the existing TA line are possible when adjusting training sessions on the Training Session Booking App or at the Sport Information Centre. Please note that the bus timetables associated with the slots are not flexible. It will not be possible to adjust the Arrival & Departure Law at the venue. Changing in training sessions must be made before 16:00 the prior day.
- For a competition transfer: No update on the timings will be available except if there is a change in the competition schedule.

For team sports dedicated transfers: For the competition venues, they can modify the schedules of bus/coaches in the planned time range of the coaches, with a margin of 15 minutes later from the village, and 15 minutes earlier from the competition venue. (The time range has been defined and approved by the sport manager and the IF.)

Example: I have a coach planned for my session at 16:15 from the Village and 20:45 from the competition:

I can request a change to leave at 16:30 maximum from the Village. Teams will not be able to leave earlier than 16:15 and later than 16:30.

Same for the way back, I can request a departure at 20:30, but I cannot leave earlier than 20:30 and later than 20:45.

→ SPECTATING ATHLETES

A distinction will be made between same discipline and different discipline spectating athletes.

- Same discipline spectating athletes will be entitled to use the TA service, except for team sports, but must give priority to competing athletes during peak times.
- Same discipline from team sports and different discipline athletes wishing to attend different discipline competitions should use TP and/or TC systems. Athletes will be able to find the most convenient route to venues by using the Paris 2024 Transport app.



OLYMPIC ROUTE NETWORK (ORN)

The Olympic Route Network (ORN) will consist of a network of roads linking all competition venues and main non-competition venues such as the Olympic Village, Porte Maillot Hub (Olympic Family Hotels 2 & 3 and Main Press Centre) as well as the International Broadcast Centre (IBC). As the ORN is dedicated to Olympic vehicles (buses and vehicles with Vehicle Access and/or Parking Permits), athletes and officials will be able to travel efficiently between the Olympic Village, competition venues and non-competition venues. Please note that the ORN is only planned for the Greater Paris area and not in co-host cities.

Olympic lanes are a subset of the ORN, comprising lanes that can be reserved for Paris 2024 vehicles. Olympic paths are also a subset of the ORN, comprising shared lanes that will serve Olympic destinations.

INTERCITY TRAVEL

Transport services will be provided to athletes and team officials between official Paris 2024 accommodation and co-host cities for competition and training (except for surfing in Tahiti), as well as for ceremonies. Intercity transport services will be provided either by coach, train, or plane according to the distances and travel time between Paris and the co-host cities. All intercity travels by train or flight for athletes and their staff will be booked in advance by Paris 2024 and are non-changeable.

Two SPS lines (specific service) will be activated on competition days to travel from Paris to Châteauroux or Lille, and the other way around. Stakeholders with TC rights will be able to use these buses. They will need to book their seats in the buses at any transport desk, at least 24 hours in advance for Chateauroux and 48 hours in advance for Lille.

PUBLIC TRANSPORT

All accredited stakeholders will be entitled to free-of-charge access to public transport (TP) services within the Greater Paris area and in co-host cities, from 15 July to 14 August 2024.

→ GREATER PARIS AREA

A physical transport card (Navigo) will be provided during the accreditation validation process for each Games stakeholder with TP privileges. Athletes and Alternate Athletes will have a digital TP card directly on their Samsung phones (distributed at the Olympic Village) given upon arrival that will work through the

Île-de-France Mobilités application. They can only request a physical TP card at any transport desk if the digital TP Card is dysfunctional. At the end of the stay, stakeholders must leave the pass in a dedicated collection box at Transport Desks and Port of Entries

In the Greater Paris area, most official venues can be reached by TP or TC. In addition, metro, RER stations and bus stops are within a short walking distance of the Olympic Village.

Approximate TP hours of operation are as follows:

- Buses from 05:45 – 00:45
- Metro from 05:30 – 01:15 (until 2:15 on Fridays and Saturdays)
- RER from 04:30 – 01:15
- Trams from 05:10 – 01:00

These hours are for information only. Full details will be available on the Paris 2024 Transport Accred app.

→ CO-HOST CITIES

In the co-host cities, most competition venues can be reached by public transport (except Tahiti). Bordeaux, Châteauroux, Lille, Lyon, Marseille, Nantes, Nice, and Saint-Etienne all have public transport systems that can be used free-of-charge by accredited stakeholders. Where applicable, access means will be distributed at the relevant co-host city.

Public transport in Châteauroux will be free of charge for both the general public and accredited stakeholders; therefore no access means will be distributed.

TRANSPORT CONNECT (TC)

The Transport Connect service (TC) is dedicated to accredited stakeholders and its aim is to complement public transport services. TC services is a regular shuttle system that connect transport hubs and public transit stations with venues, making it easier to reach venues than with public transport alone. The TP network will use various forms of transport (metro, bus, tram, RER trains) as well as TC lines. In some cases, TC lines could be replaced by TP if the journey is more direct and efficient.

TC will be operational from 15 July to 14 August 2024. Activations will start 4 hours before competition sessions and end 4 hours after competition sessions. On non-competition days, TC will be activated from 8:00 to 20:00.



A TC night loop called Noctilien has also been created to complement regular TP offer during nighttime. It will run between 26 July and 12 August 2024 with a peak frequency of 10 minutes.

TC will be activated in the Greater Paris area, Lyon area, Marseille, Lille, Chateauroux, Nantes, Nice, Bordeaux, Saint-Etienne and Tahiti.

The TC system is also available for all spectating athletes to reach competition venues. Spectating athletes can use the Paris 2024 Transport Accred app to plan their route.

Please note that TC drop-off and pick-up zones are located outside venue security perimeters.

TRANSPORT DESK

A Transport desk will be available in the NOC Services Centre at the Olympic Village, providing information on TA and other transportation systems.

Team sport bus schedules will be provided at the Transport desk in the Sport Information Centre, which is located in the same building as the NOC Services Centre (Halle Maxwell).

Transport desks will also be available at the satellite Villages and in the football hotels.

TRANSPORT APP

Paris 2024 will launch a dedicated Games-time Transport app for all accredited stakeholders. This will be different to the Île-de-France Mobilités (IDFM) transport app for public transport.

The main functionalities will include:

- Journey planner to calculate the best itineraries according to user preferences.
- Multimodal app suggesting itineraries that use both public transport services (TP) and Paris 2024 transport services (each accredited stakeholder will only see the Paris 2024 transport services that they are entitled to).
- Real-time travel information (travel time updates, next departures, and alerts).
- Booking functionalities for TX services (available according to user privileges).

The app will be available to download from the Android Play Store and Apple App Store, and will be available in French, English, Spanish.

The Transport application will be pre-installed on phones given to Athletes and Alternate Athletes.

ATHLETES' BAGGAGE AND OVERSIZED SPORT EQUIPMENT

Athletes' baggage and oversized sport equipment refers to the goods accompanying athletes and NOC team officials.

Baggage loaded onto logistics vehicles will be transported from the various Ports of Entry and arrival points within the Paris region, co-host cities and Tahiti to the relevant Village or the Paris 2024 hotel.

When oversized athletes sport equipment arrives on French territory or in French Polynesia, the final storage site will determine the types of transfers and movements during the Games.

Two main categories of movements have been identified for first-time arrivals:

- From Port of Entry or arrival point (airport or train station) to the Olympic Village, the satellite Villages and the football hotels in the co-host cities.
- From Port of Entry or arrival point (airport or train station) to competition or training venues.

SPORT EQUIPMENT INTER-VENUE TRANSPORT

A free-of-charge inter-venue transfer service will be available during the Olympic Games for oversized athletes sport equipment.

- Transfers will be organised from the Olympic Village to competition and/or training venues, as well as between competition venues and training venues.
- NOCs can request any kind of inter-venue transfers at the Logistics desk in the NOC Centre (Halle Maxwell).
- A drop-off and pick-up area for this equipment has been identified at the Olympic Village close to the Transport Mall.
- Athletes or team officials will be able to drop off and pick up oversized equipment at this area and send it to or from the competition or training venue.
- An equipment identification and tracking system (specific tag per venue) for each transfer will be used with information to complete.



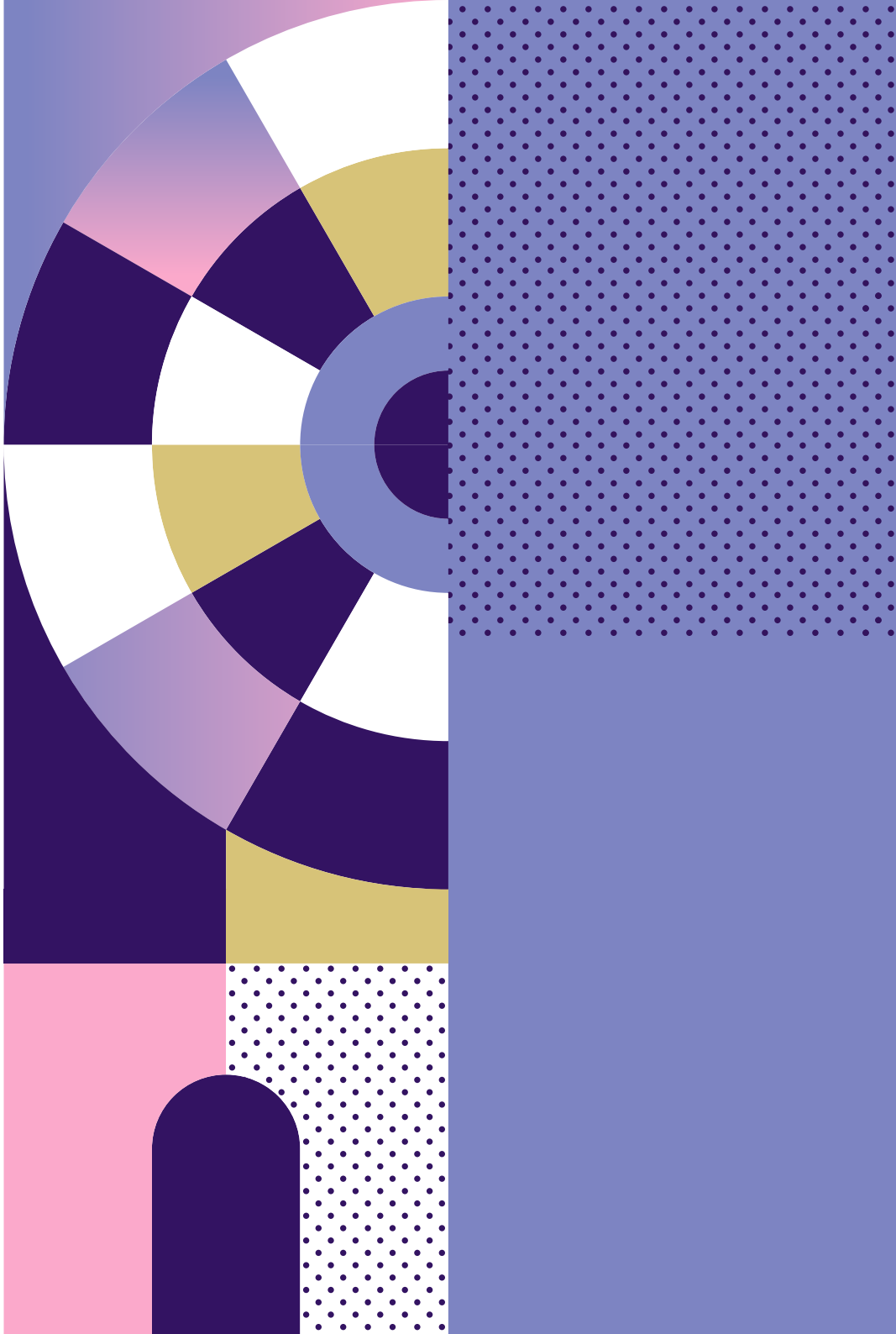

3

7

8

APPENDICES

VENUE MAP

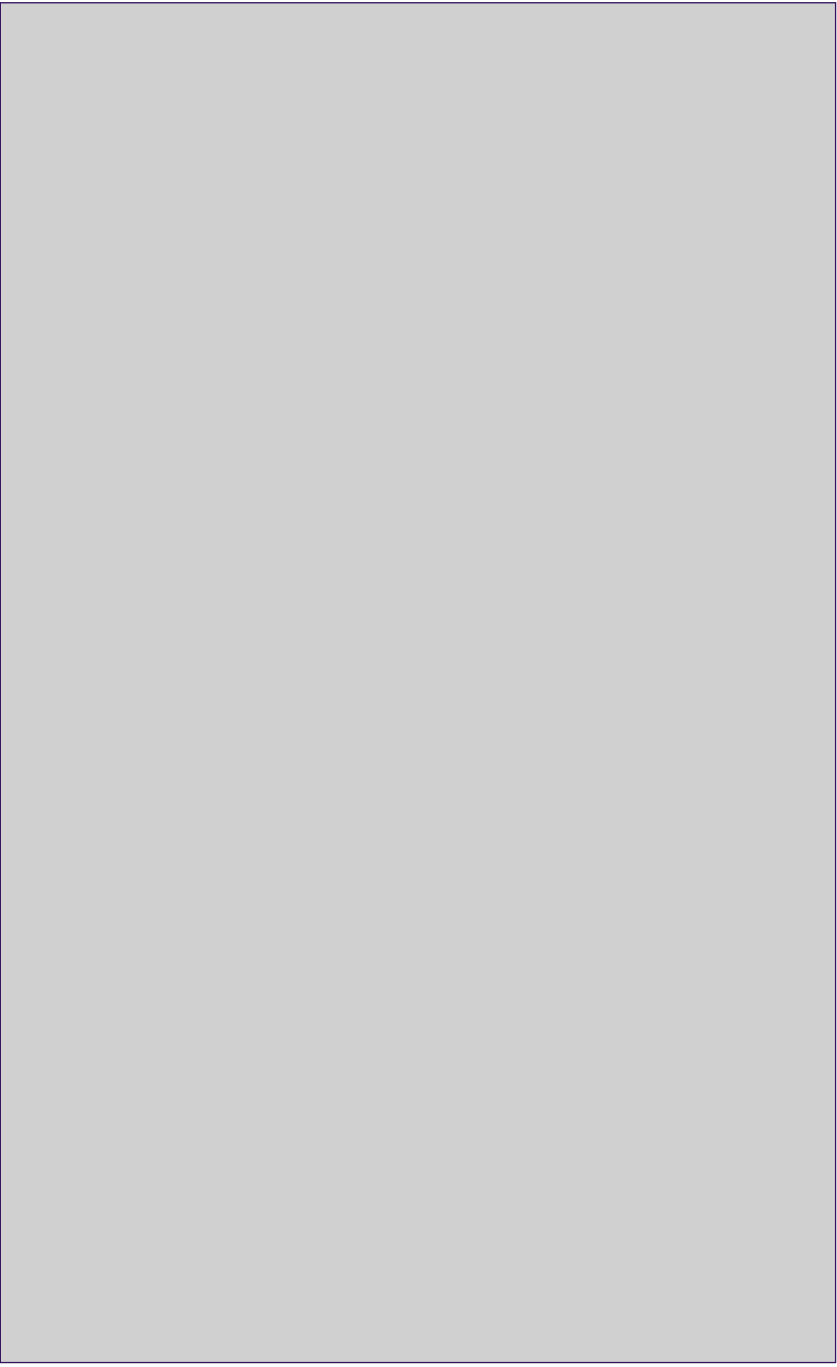



VENUE MAP

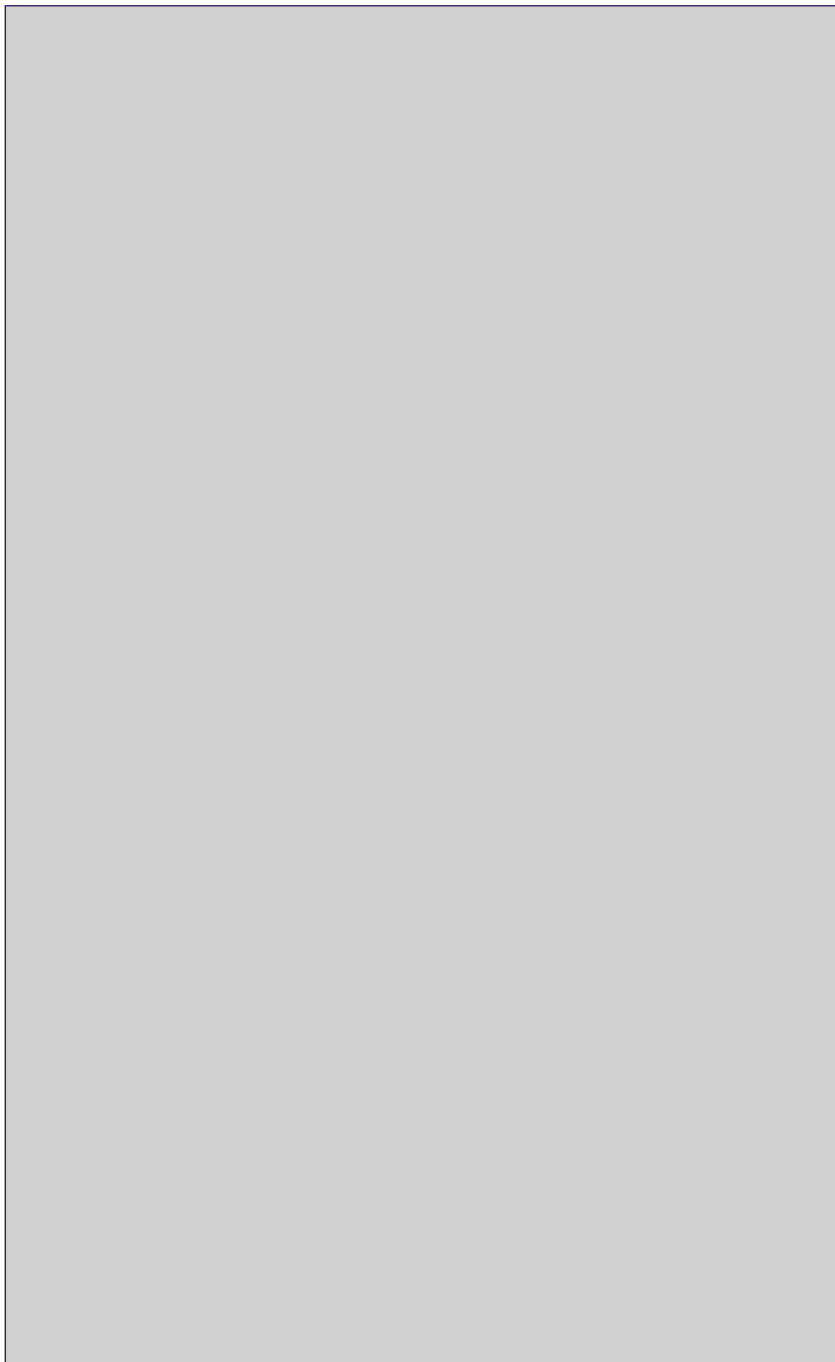

OLYMPIC VILLAGE

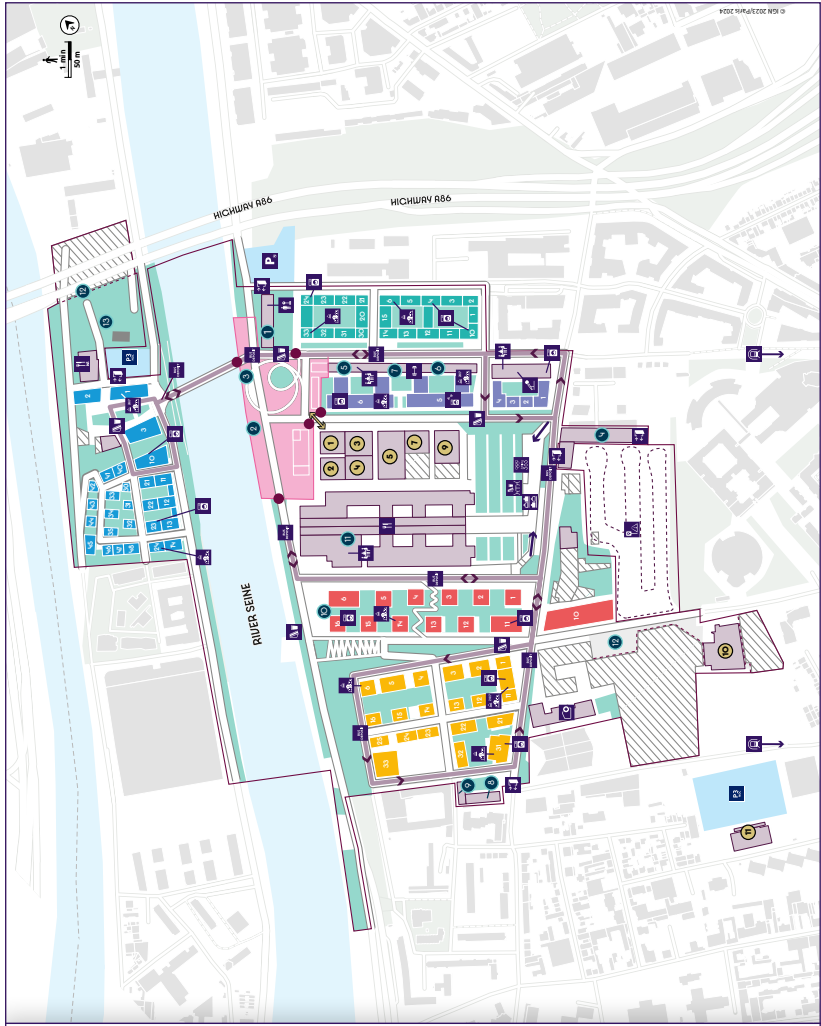

- RESIDENTIAL ZONE**
- Dauphine
 - Bastille
 - Filles
 - Étoile
- SERVICES AND OPERATIONS**
- 1 Main Entry
 - 2 Village Plaza
 - 3 Olympic Truce Mural
 - 4 Team Processing Centre
 - 5 NOC Services Centre
 - 6 Sport Information Centre
 - 7 Multi-Sport Zone
 - 8 Safe Sport Zone
 - 9 Multi-Faith Centre
 - 10 Doping Control Station
 - 11 Village Club
 - 12 Chef de Mission Hall
 - 13 NOC Container storage-space
 - 14 Place of Mourning
- TRAINING VENUES**
- 15 fencing, modern pentathlon
 - 16 fencing
 - 17 Wrestling
 - 18 Weightlifting
 - 19 Basketball
 - 20 Basket 3x3, basketball
 - 21 Airnet Jallémeur: handball, basketball
 - 22 Table Tennis: Wrestling, Breaking
- VILLAGE PLAZA**
- 23 Access point for Village
 - 24 Village reception lounge
 - 25 Nursery
 - 26 Bank
 - 27 Post office
 - 28 Plaza Café
 - 29 General Store
 - 30 Merchandise store
 - 31 Beauty & Grooming salon
 - 32 Athlete Phone Lounge
 - 33 Cultural & Tourist
 - 34 Information Centre
- RESIDENTIAL ZONE**
- 35 Abbeilles
 - 36 Dauphine
 - 37 Bastille
 - 38 Filles
 - 39 Étoile
- SERVICES AND OPERATIONS**
- 40 Security perimeter
 - 41 Village Plaza
 - 42 Operational Zone
 - 43 Residential services
 - 44 Pedestrian path with slope of 4%
 - 45 Zone control point
 - 46 Entrance/lock
 - 47 Direction to closest nearest Village Transport Service (VTS) route
 - 48 VTS bus stops
 - 49 Grab & Go stations
 - 50 XXL Grab & Go station
 - 51 Laundry deck
 - 52 Laundry for team sports
 - 53 Resident Centre
 - 54 Super Resident Centre
 - 55 NOC car park
 - 56 Main entry car park
 - 57 Transport Mall
 - 58 Athlete&S House
 - 59 Main Dining Hall
 - 60 Island Dining Hall
 - 61 Fitness Centre
 - 62 Weight-in
 - 63 Polyclinic
 - 64 SFP / OBS / IOC Studios
 - 65 Bookable meeting room
 - 66 Baggage drop-off

COMPETITION SCHEDULE

Sport	24	25	26	27	28	29	30	31	01	02	03	04	05	06	07	08	09	10	11
Competition venue	D-2	D-1	DO	D1	D2	D3	D4	D5	D6	D7	D8	D9	D10	D11	D12	D13	D14	D15	D16
Ceremonies			es ¹ 15 ^h																es ¹ 15 ^h
Athletics																			
Archery																			
Artistic Gymnastics																			
Artistic Swimming																			
Badminton																			
Basketball																			
3x3 Basketball																			
Beach Volleyball																			
BMX Freestyle																			
BMX Racing																			
Boxing																			
Breaking																			
Canoe Slalom																			
Canoe Sprint																			
Cycling Mountain Bike																			

es¹ 15^h Ceremonies | Medals | Qualifications



Sport	24		25		26		27		28		29		30		31		01		02		03		04		05		06		07		08		09		10		11	
	D-2	07	D-1	01	07	01	D1	D2	01	D2	D3	D4	D5	D6	D7	D8	D9	D10	D11	D12	D13	D14	D15	D16	D17	D18	D19	D20	D21	D22	D23	D24	D25	D26	D27	D28	D29	D30
Competition venue																																						
Cycling Road																																						
	Trocadéro																																					
	Pont Alexandre III																																					
Cycling Track																																						
	Saint-Quentin-en-Yvelines National Velodrome																																					
Diving																																						
	Aquatics Centre																																					
Equestrian																																						
	Château de Versailles																																					
Fencing																																						
	Grand Palais																																					
Golf																																						
	Le Golf National																																					
	Parc des Princes																																					
	Bordeaux Stadium																																					
	Lyon Stadium																																					
	Marseille Stadium																																					
	La Beaujoire Stadium																																					
	Nice Stadium																																					
	Geoffroy-Guichard Stadium																																					
Football																																						
	South Paris Arena 6																																					
	Pierre Mauroy Stadium																																					
Hockey																																						
	Vues-du-Flancoir Stadium																																					
Judo																																						
	Champ-de-Mars Arena																																					
Marathon Swimming																																						
	Pont Alexandre III																																					
Modern Pentathlon																																						
	Château de Versailles																																					
	North Paris Arena																																					
Cycling Mountain Bike																																						
	Elancourt Hill																																					
Rhythmic Gymnastics																																						
	Porte de La Chapelle Arena																																					



24	25	26	27	28	29	30	31	O1	O2	O3	O4	O5	O6	O7	O8	O9	O10	O11
O7	O7	O7	O7	O7	O7	O7	O7	O8	O8	O8	O8	O8	O8	O8	O8	O8	O8	O8
D-2	D-1	D0	D1	D2	D3	D4	D5	D6	D7	D8	D9	D10	D11	D12	D13	D14	D15	D16
Rowing	Competition venue Laires-sur-Merme Nautical Stadium - Retzwater																	
Rugby Sevens	Stade de France																	
Sailing	Marseille Marina																	
Shooting	Chateauroux Shooting Centre																	
Skateboarding	La Concorde																	
Sport climbing	Le Bourget Sport Climbing Venue																	
Surfing	Teahupo'o, Tahiti																	
Swimming	Paris La Defense Arena																	
Table Tennis	South Paris Arena 4																	
Taekwondo	Grand Palais																	
Tennis	Roland-Garros Stadium																	
Trampoline Gymnastics	Bercy Arena																	
Triathlon	Pont d'Alexandre III																	
Volleyball	South Paris Arena 1																	
Waterpolo	Aquatics Centre Paris La Defense Arena																	
Weightlifting	South Paris Arena 6																	
Wrestling	Champs-de-Mars Arena																	



Ceremonies



Medals



Qualifications

* The surfing competition will be held over a 4 days within a period of 9 days, depending on the weather conditions.



Paris 2024 thanks its Partners for their dedication.

Worldwide Partners



Premium Partners



Official Partners



Official Supporters

ABEO	Air Liquide	Airweave	Aquatique Show	Arena	CRYSTAL	Doublet Wasserman		
DXC Technology	Egis	Enedis	ES Global	Eviden	Fitness Park	Fnac Darty	Garden Gourmet	
Gerflor	Groupe RATP	Highfield	Hype	INDIGO	La Poste	Loxam	Lyreco	Miko
Mondo	MTD	Myrtha Pools	OnePlan	Optic 2000	Ottobock	Randstad	Rapiscan Systems	
Re-uz	RGS Events	Saint-Gobain	Salesforce	SCC	SEDIF	SLX	SNCF	Sodexo Live!
Technogym	Terrailon	Thermo Fisher Scientific	Tourtel Twist	VINCI	Viparis	Westfield		



www.paris2024.org

[f](#) Paris2024 | [X](#) Paris2024 | [in](#) Paris 2024

[📷](#) paris2024 | [📺](#) Paris 2024 | [🎵](#) paris2024officiel