

ABOVE GROUND POOL

NAKOMA ROUND

INSTALLATION MANUAL

95-0431

ABOVE GROUND POOL SAFETY

PLEASE READ BEFORE INSTALLATION



WARNING

FAILURE TO HEED THESE WARNINGS CAN RESULT IN PERMANENT INJURY, PARALYSIS FROM A BROKEN NECK, ELECTROCUTION OR DROWNING.

THIS POOL IS NOT DESIGNED FOR DIVING OR JUMPING!
DANGEROUS INJURY CAN RESULT. SHALLOW WATER!

Carefully read, understand and follow all information in this user manual before installing and using the swimming pool. These warnings, instructions and safety guidelines address some common risks of water recreation, but they cannot cover all risks and dangers in all cases. Always use caution, common sense and good judgment when enjoying any water activity. **RETAIN THIS INFORMATION FOR FUTURE USE.**

Your pool contains a large quantity of water, and is deep enough to present inherent dangers to life and health unless the following safety rules are strictly observed. First-time users run the highest risk of injury. Make sure everyone understands and encourage all users especially children to learn how to swim. Learn Basic Life Support (Cardiopulmonary Resuscitation-CPR) and refresh this knowledge regularly. Instruct all pool users, including children, what to do in case of an emergency. Keep a working phone and a list of emergency phone numbers near the pool. This can make a life-saving difference in the event of an emergency. To ensure your pool is used safely you **MUST** observe the following safety precautions:

1. NO JUMPING OR DIVING

The top rail of your pool is not a walkway and must not be used for jumping or diving. Do not permit jumping or diving into the pool from a deck or the top rail of the pool. Diving or jumping into the pool can result in serious injury.

2. NEVER USE THE POOL ALONE

Never permit the pool to be used unless it is attended by at least one person other than the bather. Someone should always be available to lend assistance in an emergency. Designate a competent adult to supervise the pool each time it is being used. Vigilant supervision of weak swimmers and non-swimmers by a competent adult is required at all times, remembering that children under five are at the highest risk of drowning.

3. NEVER LEAVE CHILDREN UNATTENDED

Never leave a child alone and unsupervised in or near the pool—not even for a second. There is no substitute for constant adult supervision.

4. NO ROUGH PLAY

Do not permit "roughhousing" in and around your pool. Surfaces can become slippery and hazardous when wet.

5. LIGHT THE POOL AT NIGHT

If the pool is used after dusk, adequate lighting must be provided. Illumination in the pool area must be sufficient to clearly judge pool depth and all features in and around the pool. For lighting recommendations, consult your local licensed electrical contractor

6. RESTRICT ACCESS TO THE POOL

Do not leave chairs or other furniture beside the pool that could be used by a child to climb up into the pool. Ladders must be removed whenever the pool is unattended. A fence with a lockable gate around the pool or yard is strongly recommended and may be required by law in some jurisdictions. Secure doors and windows, where applicable to prevent unauthorized access to the swimming pool. Remove all toys from the swimming pool and surrounding area when not in use to avoid attracting children to the pool. Barriers, pool covers, pool alarms or similar safety devices are helpful aids, but they are not substitutes for continuous adult supervision.

7. NO ALCOHOL OR DRUGS

Never drink alcoholic beverages, use any intoxicants or medication which could hinder your judgment and reflexes.

8. KEEP YOUR POOL CLEAN AND SANITARY

Your filter system will remove suspended particles from the water and the surface skimmer will remove insects, leaves and other debris from the water surface. Use the correct pool chemicals as directed to destroy harmful bacteria and prevent formation of algae. Remember, unsanitary water is a serious health hazard.

9. KEEP OFF TOP LEDGES

Do not walk on top ledges. They can be slippery and they are not a walkway.

10. POOL COVER SAFETY

The cover must have a tamperproof locking retainer cable that positions the cover around the pool wall and keeps it securely in place. Never allow anyone, especially small children on the cover. Asphyxiation or drowning could result. Be sure to remove pool cover completely from the water surface before entering the pool. When purchasing any pool cover, please consult a swimming pool professional.

11. ELECTRICAL HAZARD

Never touch or attempt to service electrical equipment, including the filter when your body and/or the ground is wet. Electrocution or permanent injury due to high voltage (120V AC) could result. The pool should be bonded in accordance with Section 680-26 of the National Electrical Code. For further assistance contact your dealer or a local licensed electrician. Do not use pool during electrical or rain storms.

12. SAFETY EQUIPMENT

Keep a safety rope 1/4" by 50" with a flotation buoy with an outside diameter of 15". Have accessible in a prominent area by your pool. Keep a pole not less than 16 feet (4,88m) long with a blunt or hook end available at poolside in case of emergencies. Weak swimmers and non-swimmers should wear personal protection equipment when using the pool.

13. POOL CHEMICALS

Store pool chemicals out of the reach of children. Do not place chlorine, chlorine tablets or sticks directly into skimmer, or winterize your pool with liquid chlorine. Damage to the skimmer, pool liner and filter will result. Failure to obey this instruction will void all component warranties. Always follow chemical manufacturer's instructions when storing, handling and dispensing pool chemicals.

14. CHECK FOR DAMAGE

Periodically check your pool and ladder components for damage and wear. Be sure all screws are in place. Replace all damaged or worn components and tighten all screws before you use the pool, deck or ladders. At first sign, remove rust and touch up immediately.

15. POOL PARTS

Never modify the pool or accessories, or remove or drill holes in the pool, deck or ladder components unless instructed. Your pool wall is made of thin metal, there is an inherent cut hazard with metal so use gloves during installation. Always use Original Equipment Manufactured parts for your replacement parts.

FOLLOW ALL SAFETY INSTRUCTIONS

Read and follow all safety instructions packaged with pool, ladder, deck or any other accessory. Additional pool safety publications can be obtained by contacting: The Association of Pool & Spa Professionals (www.apsp.org)



IMPORTANT NOTICE READ BEFORE INSTALLATION!

The safety stickers must be installed as per following instructions. Failure to properly install warning labels will void warranty. Failure to mount these safety labels may subject you to substantial liability in case of injury. These warnings are not to be removed under any circumstances! If they become discolored or fall off please request replacements which will be sent at no charge.

PLACE SIGN ON LINER ABOVE WATER LINE, OPPOSITE ENTRY TO POOL



PLACE SIGN ON WALL NEXT TO POOL ENTRY



REMEMBER TO WATCH CHILDREN



IMPORTANT INFORMATION ABOUT YOUR LINER

We do not make or supply liners for our pools.

Please contact your liner's manufacturer with questions or if instructions are not included with the liner.

Liner must be installed per the liner manufacturer's instructions.

Incorrect liner installation may void the warranty.

STEP 1: POOL LOCATION

Do not locate pool over underground lines, septic tanks, under electrical lines, near hazardous structures, or out of local code restrictions. It is essential that the area selected for your pool has a level and firm base. Do not assemble your pool on asphalt, tar or oil-based surfaces. Avoid areas with sharp objects, or ground treated with weed killer or other chemicals. Also avoid areas where nut grass, Bermuda grass or bamboo grass grows, as they can grow through your liner. Grass must be removed. Do not place components such as filters, pumps, and heaters in a way that they can be used as a means of access to the pool by young children. Be sure to follow all local building codes and obtain all building permits required for your area.

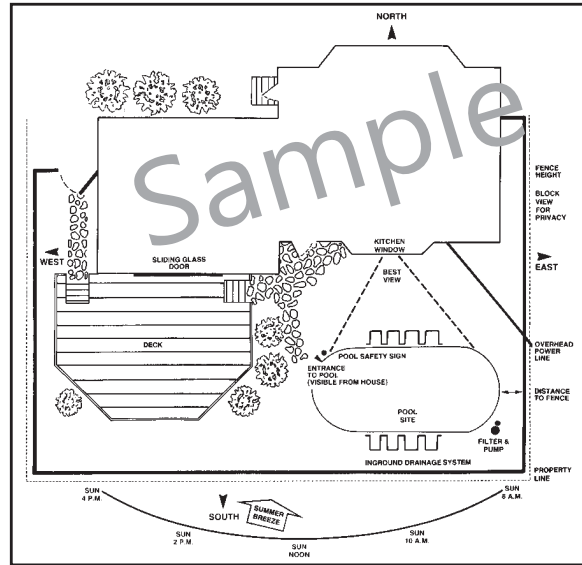

- *BE SURE TO AVOID:
- All electrical wires
 - All gas lines
 - Septic tanks
 - Cesspools
 - Dry wells
 - Tree roots/stumps
 - buried debris (trees, building material, etc.)
 - sudden slopes within 6' of pool area

STEP 2: PREPARE THE POOL SITE

Determine the pool circumference by putting a stake in the ground at the center of the location desired, and, with a line equal in length to the radius of the pool area (1/2 the pool size plus 12"), mark off the circumference with a sharp object, lawn edger, white powder, or spray paint. Remove all of the sod and grass within the marked circle.

After all of the sod has been removed from the pool site, you must make the pool area absolutely level as measured by a level or transit, not simply by the naked eye. Find the lowest spot within the pool area and level the ground to that lowest spot. Do not add dirt to the low areas as that will cause settling after the pool is filled with water. It is the high areas that must be dug away. The footing (perimeter) of the pool must be a solid foundation to prevent the pool from settling into dirt that is loosened by rain and water splashing over the side. Once again, clean the area of all sharp objects, including roots that can damage your swimming pool. For leveling, we recommend that you use a long, straight edged board and a carpenter's level or transit.

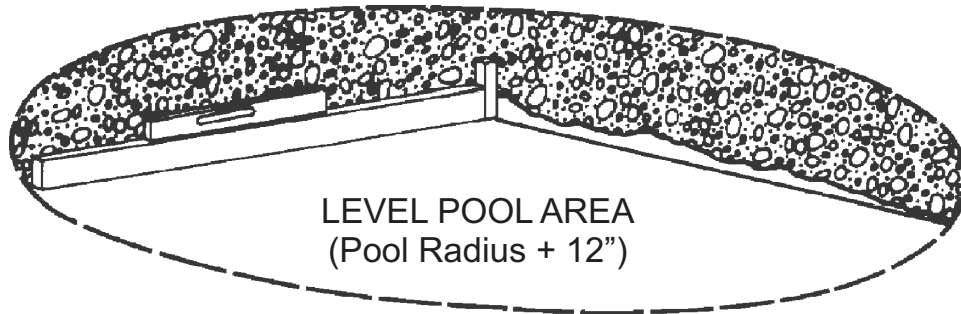

Remove soil and grass from high areas to be equal with the low areas.

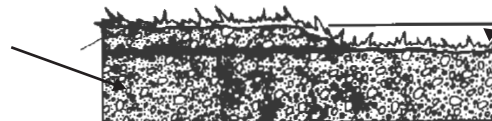

Remove grass only from the low areas.

- Bottom Rail
50" X 9'0"R X 13 Places
- Inner Stabilizer
50" X 9'0"R X 13 Places

Gap between bottom rails
in the bottom cuff is 2-5/16"

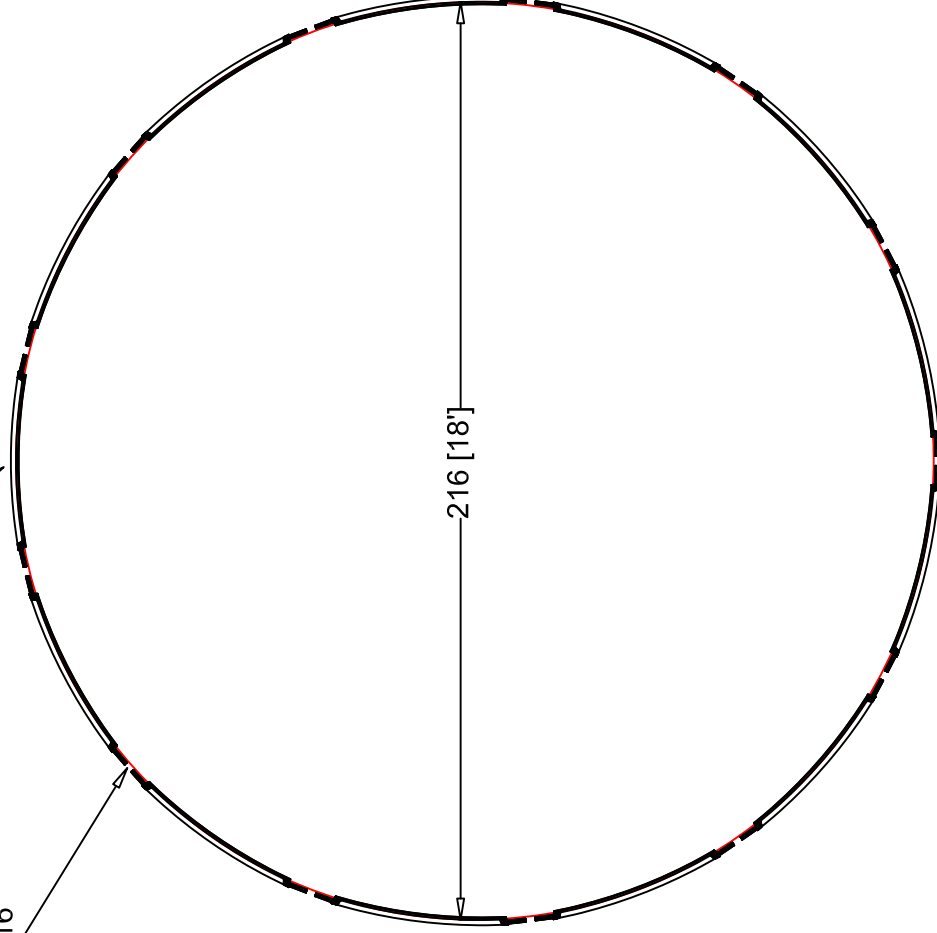

Measure rail like this

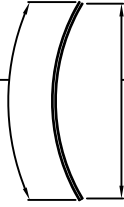

DO NOT measure rail like this

Notes:

1. Wall length is 681"
2. The bottom and top rails are made out resin material.
3. Bottom Cuff not shown in drawing.
4. All dimensions are in inches unless otherwise specified.
5. All dimensions are referenced from the wall location.
6. Manufacturers tolerances and field condition may result in dimensional variations.

- Bottom Rail
49" X 7'6"R X 11 Places
- Inner Stabilizer
49" X 7'6"R X 11 Places

Gap between bottom rails
in the bottom cuff is 2-3/16"

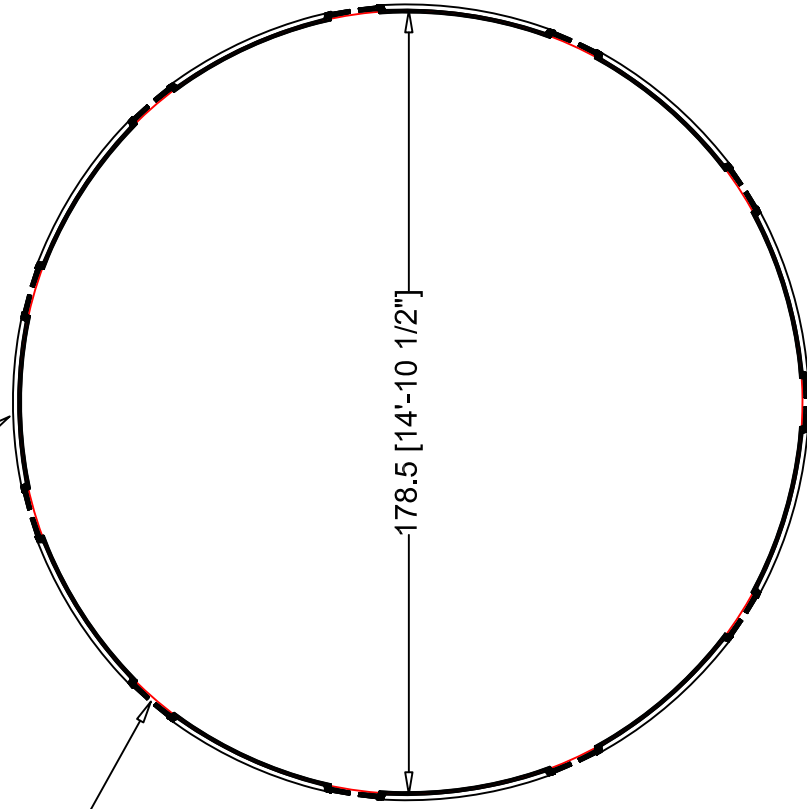

Measure rail like this

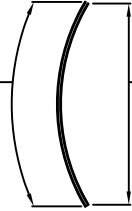

DO NOT measure rail like this

Notes:

1. Wall length is 563"
2. The bottom and top rails are made out resin material.
3. Bottom Cuff not shown in drawing.
4. All dimensions are in inches unless otherwise specified.
5. All dimensions are referenced from the wall location.
6. Manufacturers tolerances and field condition may result in dimensional variations.

POOL 15'

- Bottom Rail
48" X 12'0"R X 16 Places
- Inner Stabilizer
48" X 12'0"R X 16 Places

Gap between bottom rails
in the bottom cuff is 2-5/16"

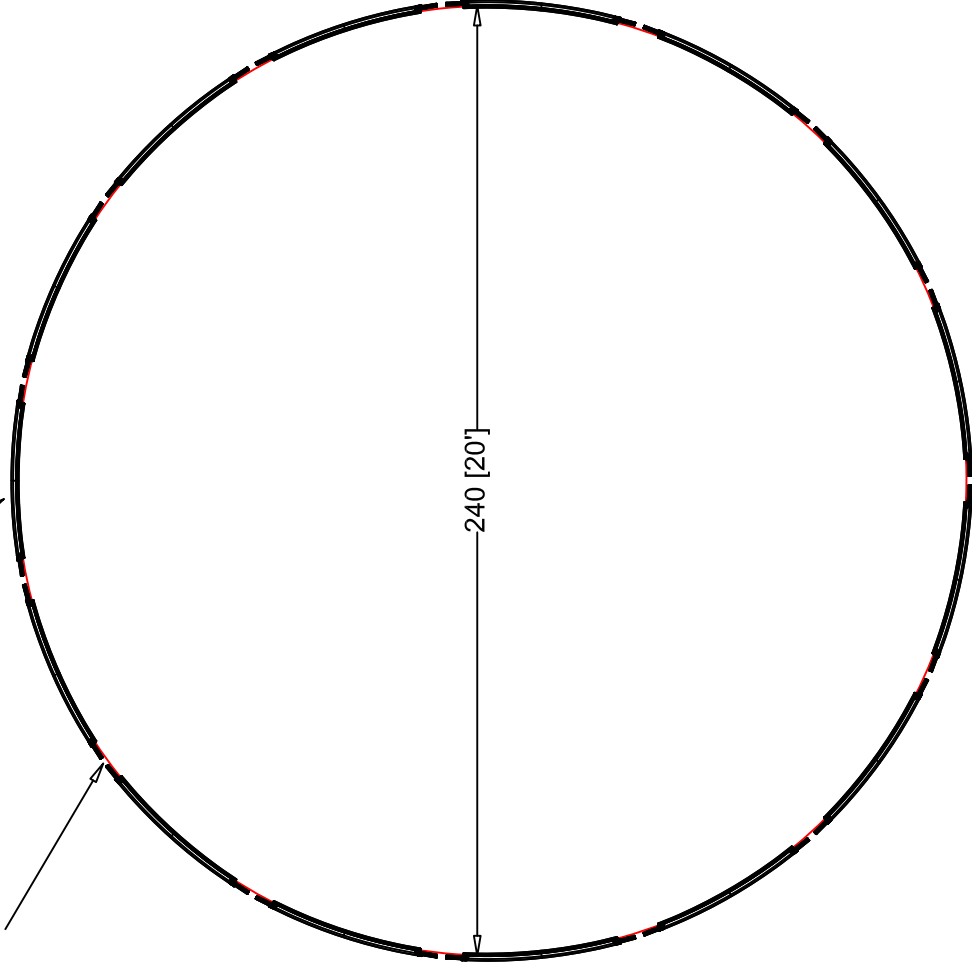

Measure rail like this

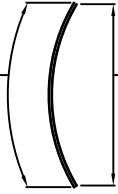

DO NOT measure rail like this

- Notes:
1. Wall length is 751"
 2. The bottom and top rails are made out resin material.
 3. Bottom Cuff not shown in drawing.
 4. All dimensions are in inches unless otherwise specified.
 5. All dimensions are referenced from the wall location.
 6. Manufacturers tolerances and field condition may result in dimensional variations.

POOL 20'

- Bottom Rail
48" X 120"R X 16 Places
- Inner Stabilizer
48" X 120"R X 16 Places

Gap between bottom rails
in the bottom cuff is 2-5/16"

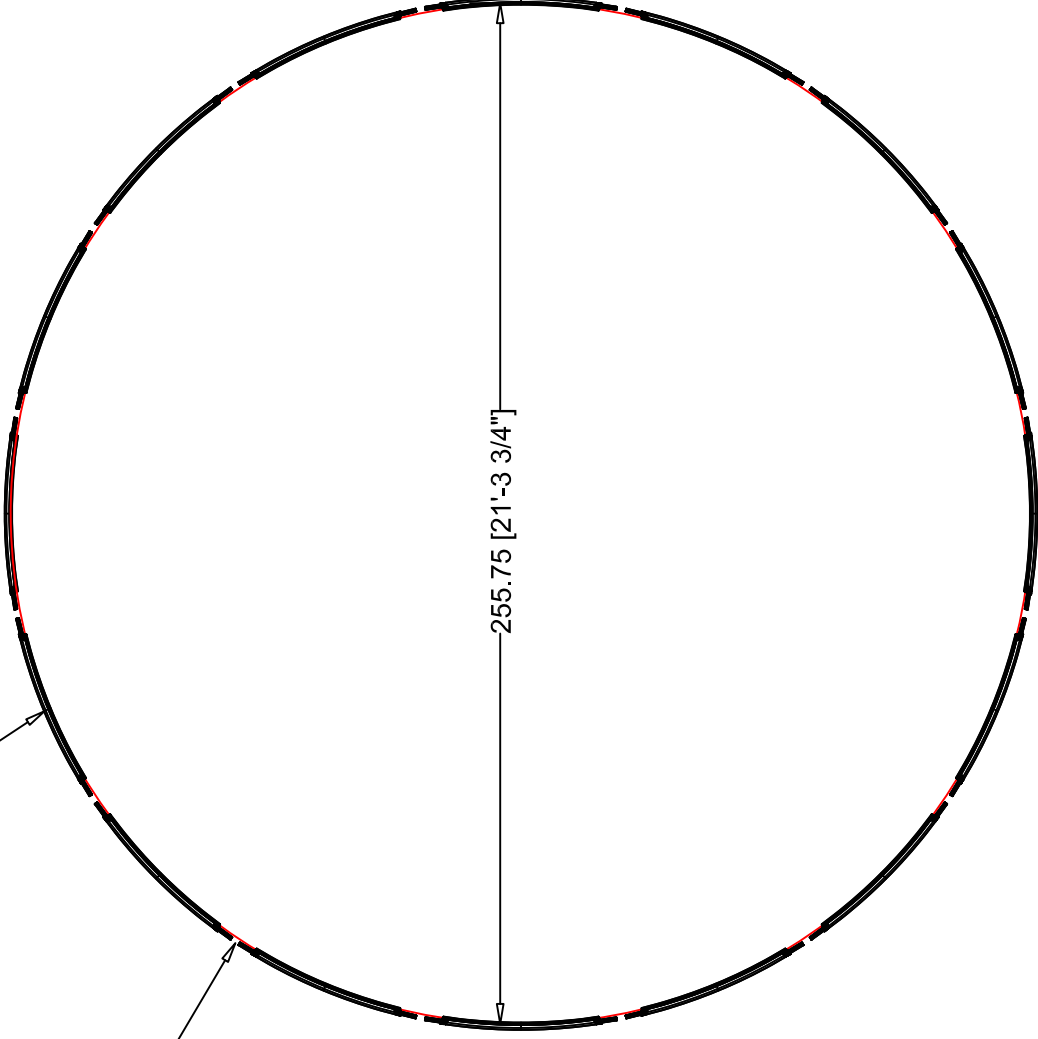

Measure rail like this

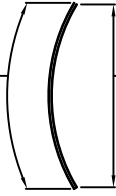

DO NOT measure rail like this

- Notes:
1. Wall length is 805"
 2. The bottom and top rails are made out resin material.
 3. Bottom Cuff not shown in drawing.
 4. All dimensions are in inches unless otherwise specified.
 5. All dimensions are referenced from the wall location.
 6. Manufacturers tolerances and field condition may result in dimensional variations.

- Bottom Rail
48" X 120"R X 18 Places
- Inner Stabilizer
48" X 120"R X 18 Places

Gap between bottom rails
in the bottom cuff is 2-5/16"

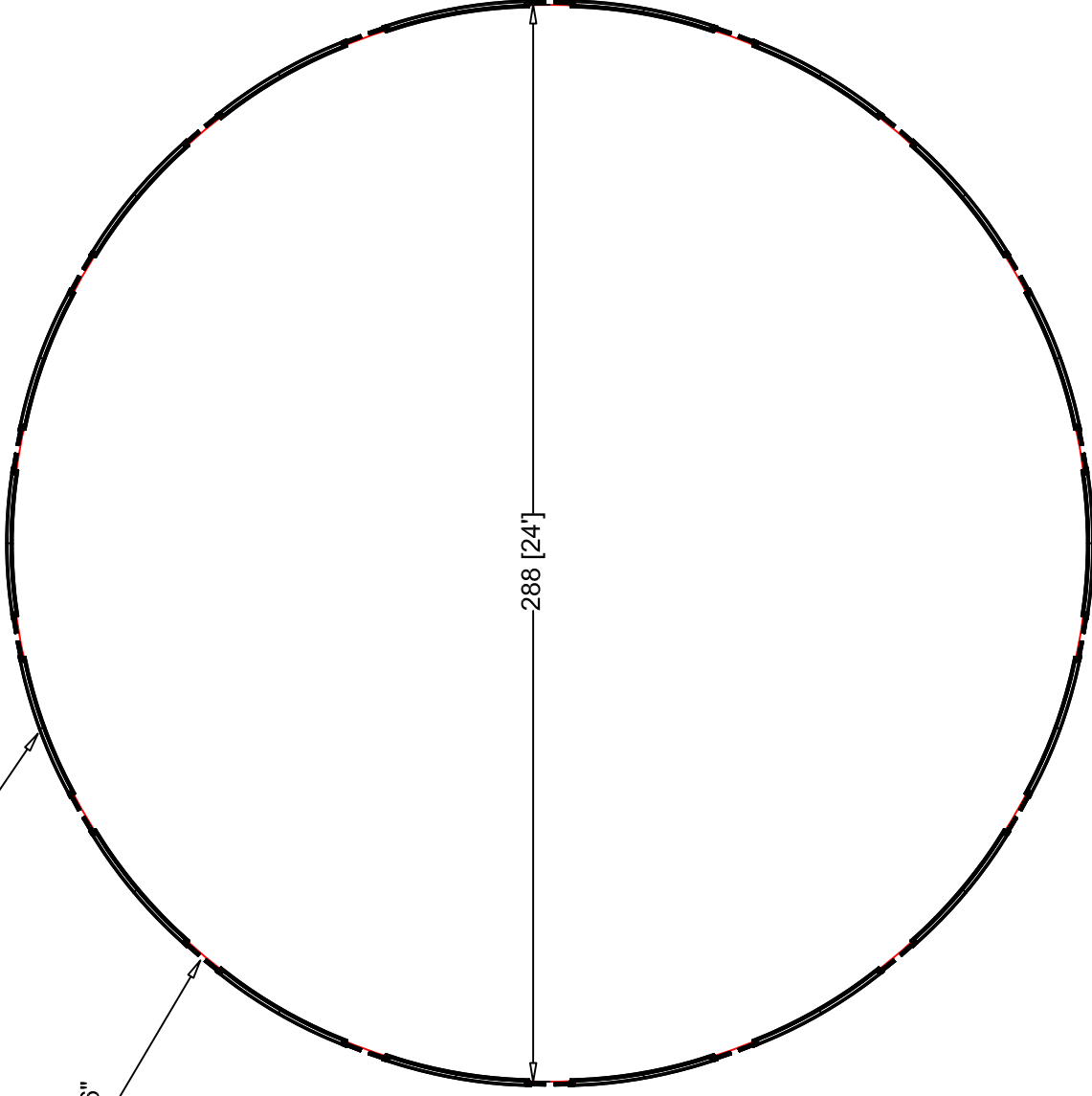

Measure rail like this

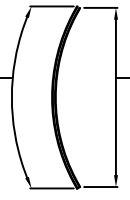

DO NOT measure rail like this

- Notes:
1. Wall length is 907"
 2. The bottom and top rails are made out resin material.
 3. Bottom Cuff not shown in drawing.
 4. All dimensions are in inches unless otherwise specified.
 5. All dimensions are referenced from the wall location.
 6. Manufacturers tolerances and field condition may result in dimensional variations.

POOL 24'

- Bottom Rail
48" X 12'0"R X 20 Places
- Inner Stabilizer
48" X 12'0"R X 20 Places

Gap between bottom rails
in the bottom cuff is 2-5/16"

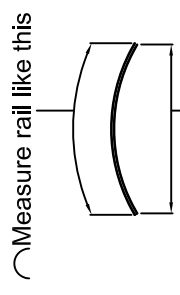
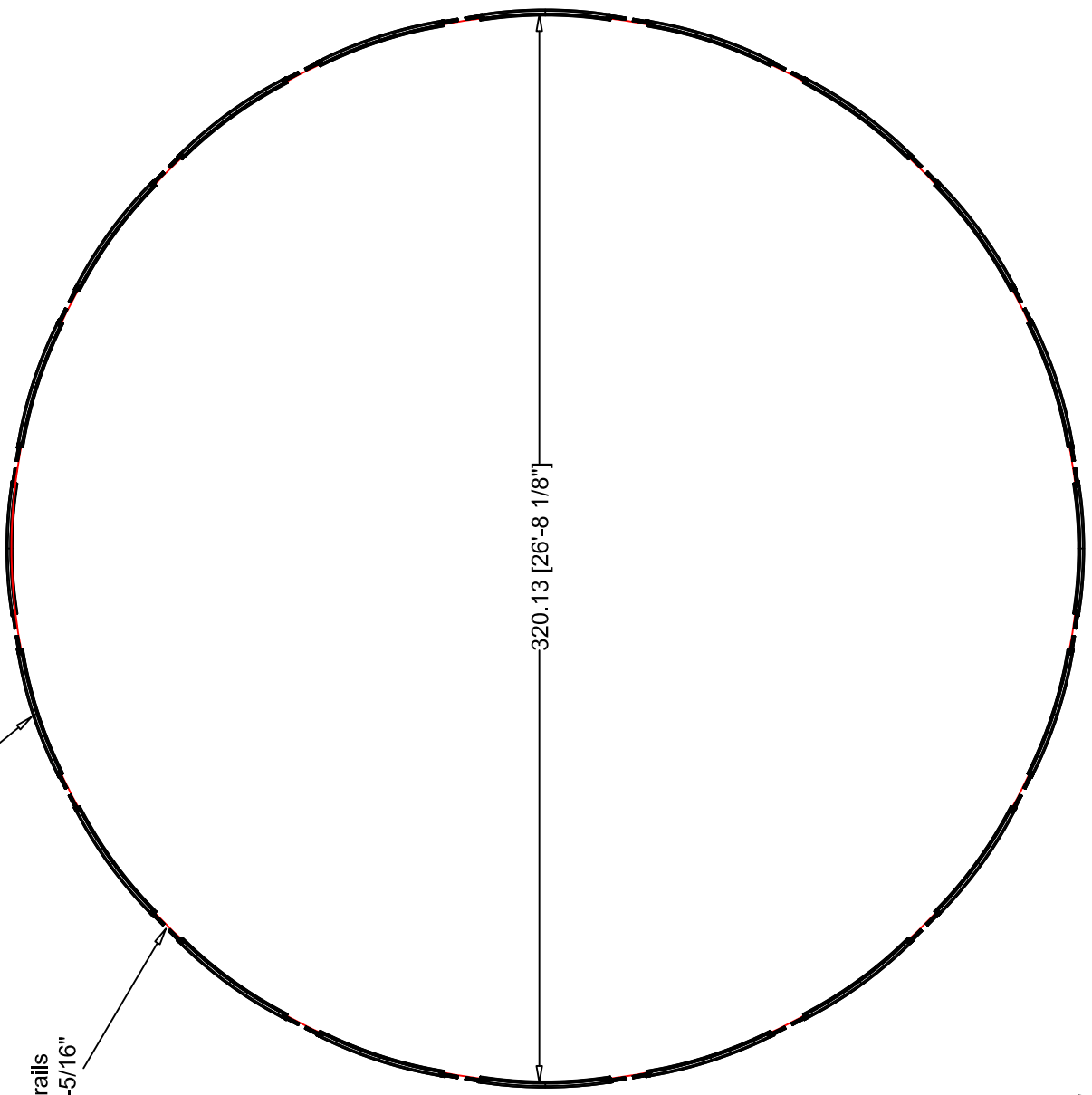

DO NOT measure rail like this

- Notes:
1. Wall length is 1007"
 2. The bottom and top rails are made out resin material.
 3. Bottom Cuff not shown in drawing.
 4. All dimensions are in inches unless otherwise specified.
 5. All dimensions are referenced from the wall location.
 6. Manufacturers tolerances and field condition may result in dimensional variations.

- Bottom Rail
- 48" X 12'0"R X 21 Places
- Inner Stabilizer
- 48" X 12'0"R X 21 Places

Gap between bottom rails
in the bottom cuff is 2-5/16"

Measure rail like this

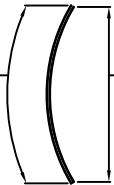

DO NOT measure rail like this

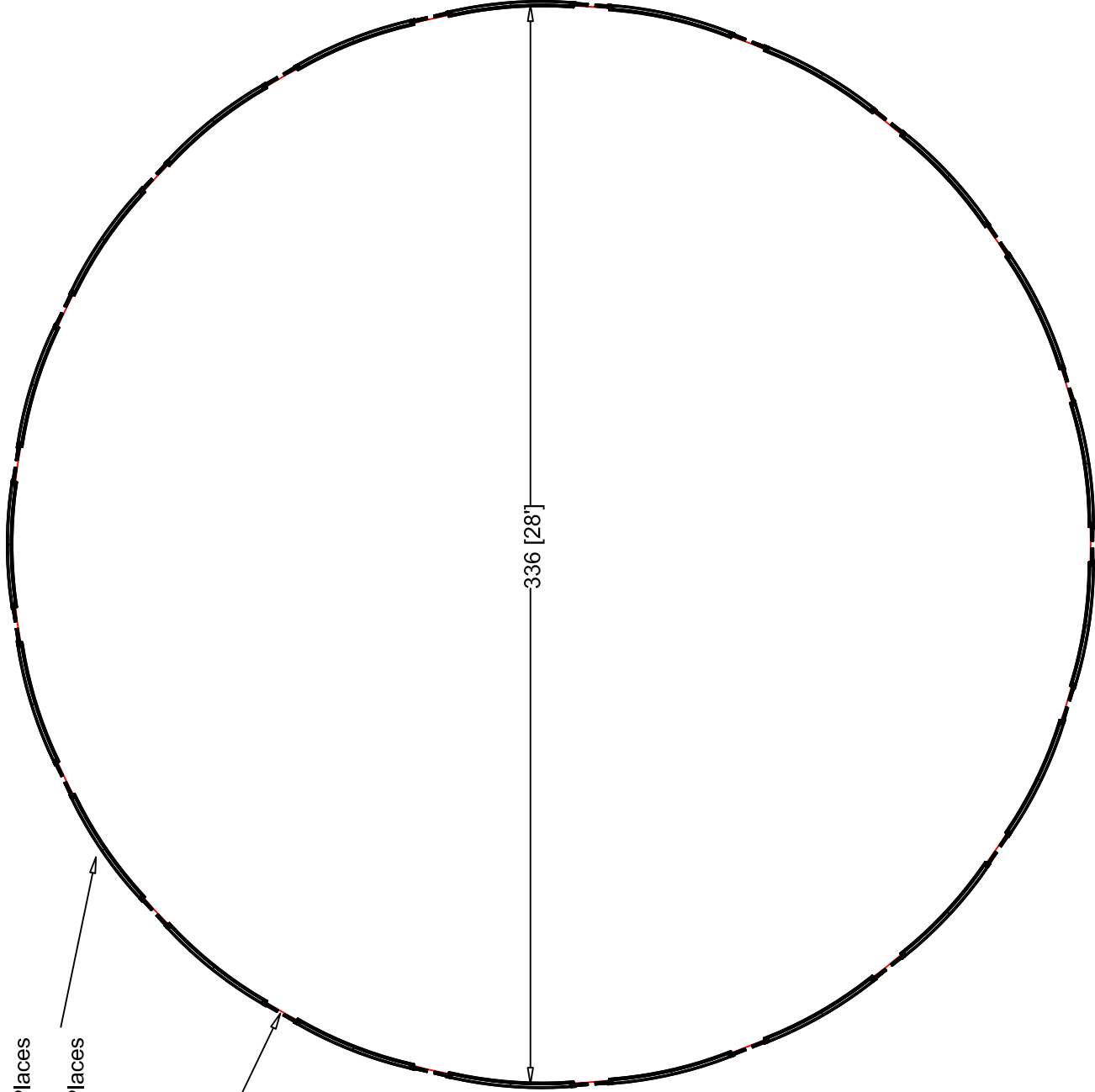

- Notes:
1. Wall length is 1059"
 2. The bottom and top rails are made out resin material.
 3. Bottom Cuff not shown in drawing.
 4. All dimensions are in inches unless otherwise specified.
 5. All dimensions are referenced from the wall location.
 6. Manufacturers tolerances and field condition may result in dimensional variations.

- Bottom Rail
49-1/2" X 16'6"R X 22 Places
- Inner Stabilizer
49-1/2" X 16'6"R X 22 Places

Gap between bottom rails
in the bottom cuff is 2"

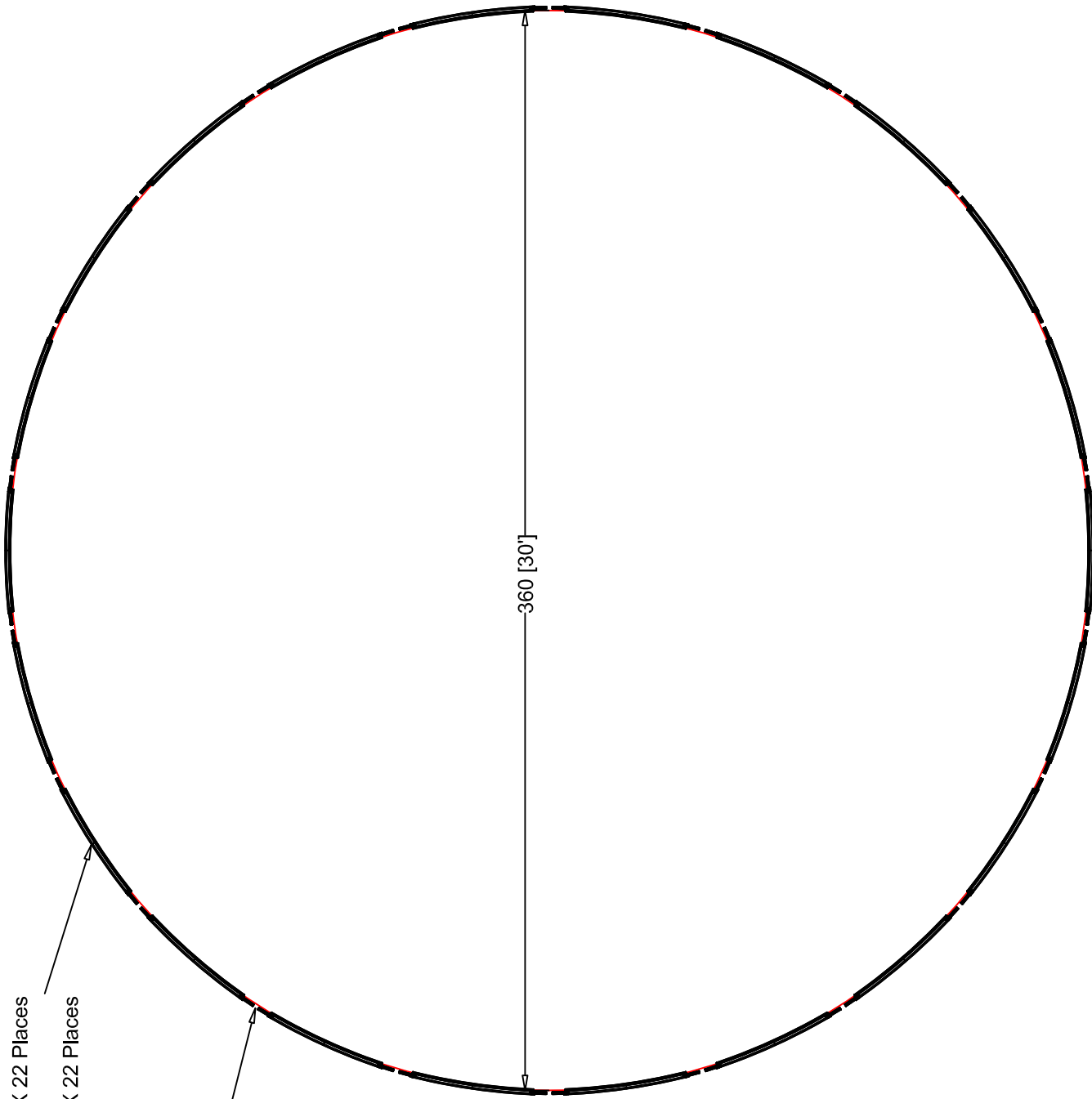

Measure rail like this

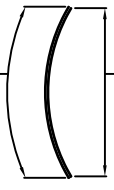

DO NOT measure rail like this

- Notes:
1. Wall length is 1133"
 2. The bottom and top rails are made out resin material.
 3. Bottom Cuff not shown in drawing.
 4. All dimensions are in inches unless otherwise specified.
 5. All dimensions are referenced from the wall location.
 6. Manufacturers tolerances and field condition may result in dimensional variations.

- Bottom Rail
49-1/2" X 16'6"R X 24 Places
- Inner Stabilizer
49-1/2" X 16'6"R X 24 Places

Gap between bottom rails
in the bottom cuff is 2-5/16"

Measure rail like this

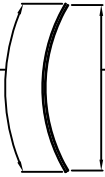

DO NOT measure rail like this

396 [33']

- Notes:
1. Wall length is 1246"
 2. The bottom and top rails are made out resin material.
 3. Bottom Cuff not shown in drawing.
 4. All dimensions are in inches unless otherwise specified.
 5. All dimensions are referenced from the wall location.
 6. Manufacturers tolerances and field condition may result in dimensional variations.

PARTS BREAKDOWN

Once you have completed the ground preparation, you should open all cartons to the pool and become familiar with all of its components. You should also refer to the breakdown sheet that is packed with your pool and make sure that you have the correct number of each component necessary to complete your pool. If you are missing any parts, or you have received any damage parts, you should notify the dealer where you purchased the pool before beginning the assembly.

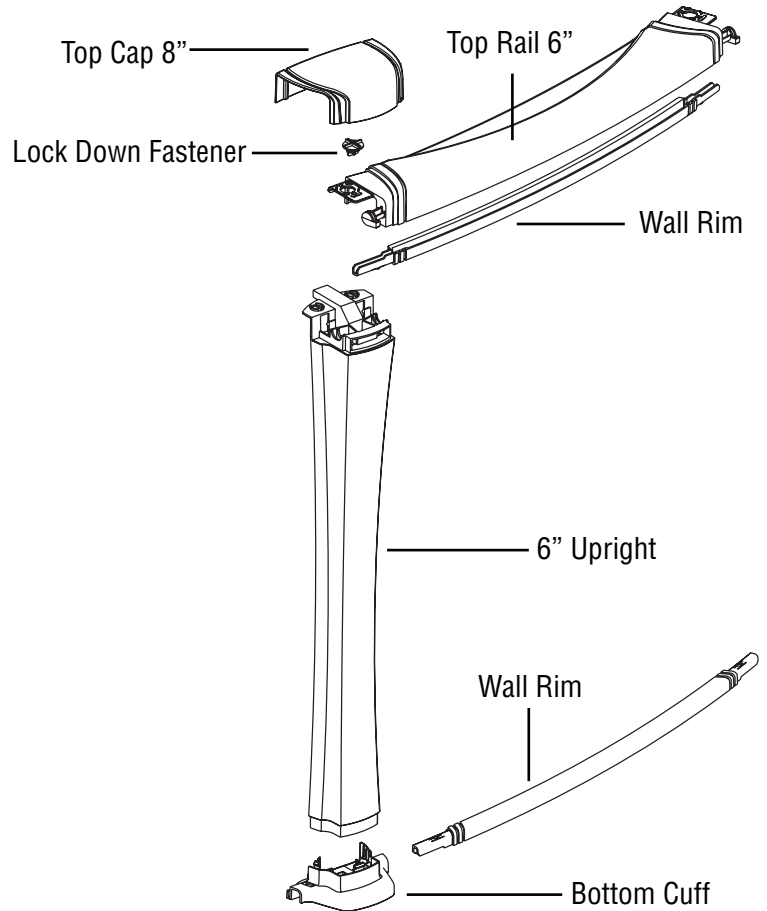

STEP 3: BOTTOM RING ASSEMBLY

Take half of the wall rims and place them in a circle along the circumference of the pool area. Assemble the wall rims by using the bottom cuffs to join them together as shown in the diagram. Do not be alarmed that the pieces do not lock together tightly, there is some room for adjustments should you need it while installing the wall in steps five and six. Check the roundness of your circle by measuring the diameter across in several locations. **DO NOT SKIP THIS STEP!** Otherwise, you might end up with an oval shape, which will cause problems later on. Once you have established a true circle, stake the wall rims at every other rim with a screwdriver or small stake (as shown in diagram B), to ensure that it stays in place during the remainder of the installation.

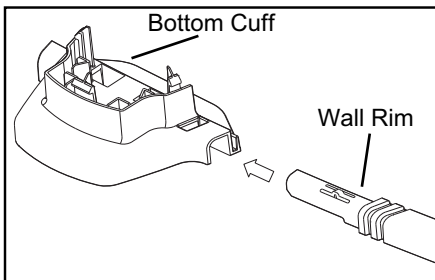

Diagram A

* Adjust rims in or out as necessary to form a true circle.

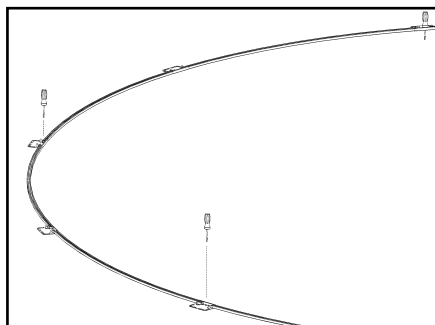
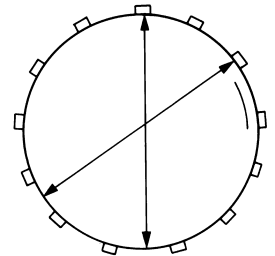
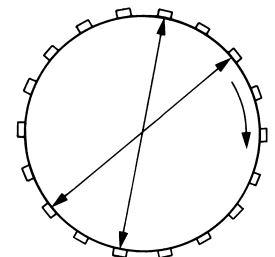

Diagram B

FOR 15', 18', 20', & 28' POOLS: Measure from bottom cuff to center of opposite bottom cuff at every other bottom cuff. When true, stake into position.



FOR 24' & 33' POOLS: Measure from bottom cuff to opposite bottom cuff at every other plate. When true, stake into position.



STEP 4: PATIO BLOCK INSTALLATION

Once the frame is in position, begin centering bottom plates on 2"x8"x16" patio blocks. Sink patio block into ground under bottom cuff, making sure that the block is level in all directions (side to side as well as front to back). Repeat this step around the frame making the tops of all blocks level with the ground. Do not install blocks or rims on loose sifted soil or sand. There must be no space between the ground and the bottom of the rims. All patio blocks must be flush with the ground, solid and level with each other in all directions. You may remove a wall rim at this time to cart in sand or sifted soil for the cove (step 9) as long as your pool ring remains staked in position. Make sure you replace the wall rim in its proper position.

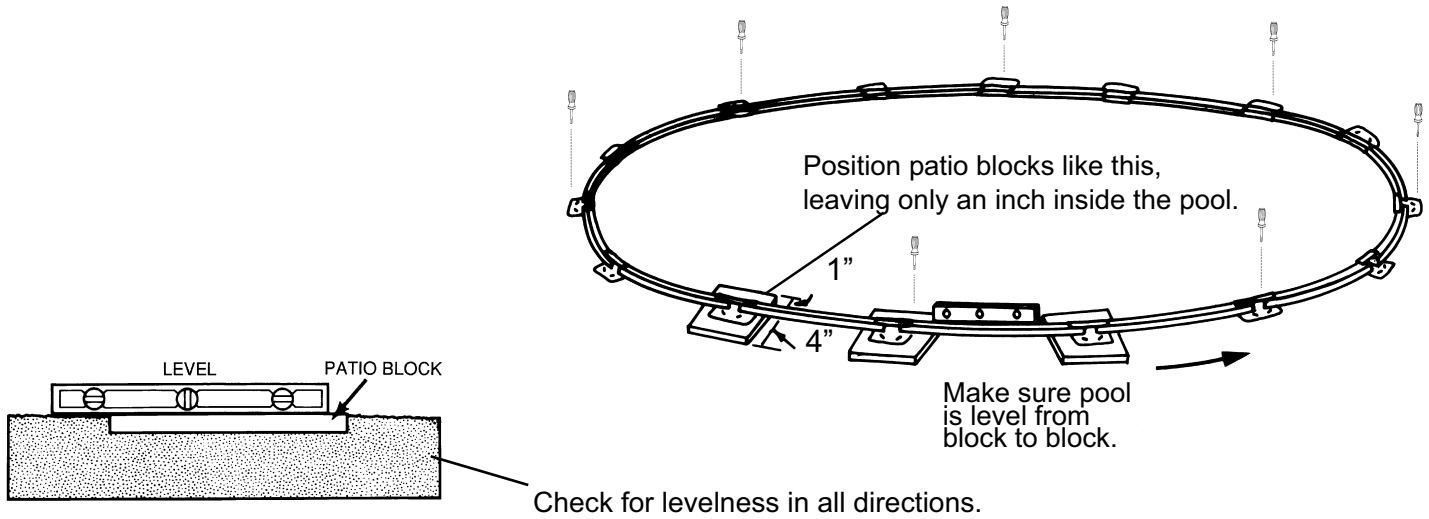

STEP 5: WALL INSTALLATION

In this step, you will use the wall carton as a base to unravel the pool wall. Locate the area that you wish to put the skimmer and return so that you can start the wall behind the appropriate upright. Unravel the wall a little at a time, inserting into the wall rims as you go. Do not unravel the entire wall at once, this makes installation much more difficult. As you unravel the wall you will need something to hold it up. We recommend placing landscaping stakes around the outside of the pool and clipping the wall to the stakes as you go. If you cannot get landscaping stakes the other option is to temporarily install wall rims on top and uprights to keep the wall in place. (step 13)

If the side wall seems too long or too short, make the bottom ring larger or smaller by equally sliding the wall rims in or out of the bottom cuffs. If the ground is uneven, the wall may jump out of the bottom track. Correct this condition by rechecking the level.

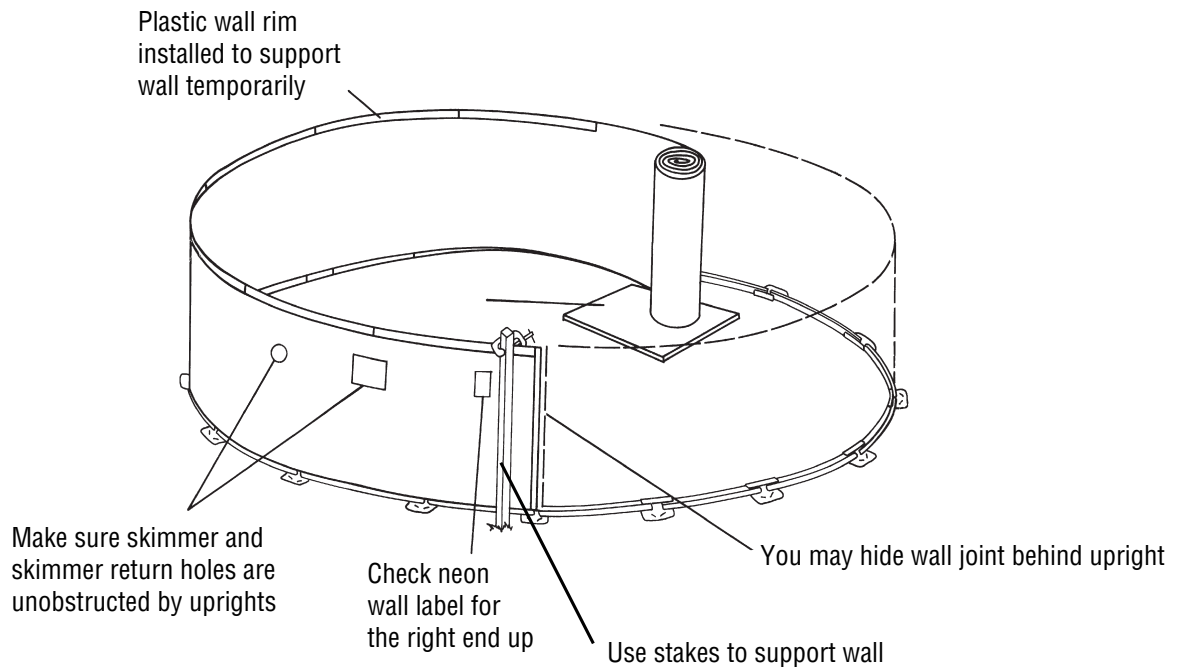

STEP 6: WALL JOINT ASSEMBLY

IMPORTANT- This operation must be done carefully! When joining the sidewall, make sure that the aluminum strips do not touch each other. One bar must be inside the pool (the bolts will touch this bar) and one bar must be outside the pool (the nuts will touch this bar). Insert the bolts with the bolt head to the inside and the nuts to the outside of the pool. Do not tighten until all bolts have been inserted. If your screwdriver slips and scratches the head of the bolt, file the scratch smooth so that it cannot puncture the liner. Cover the heads of the bolts, on the inside of the wall, with three layers of duct tape. If the insertion of the wall in the bottom rail is tight at the point where the wall is joined together, insert a screwdriver and twist to make enough room, again being sure not to scratch the wall or the wall rim. (*Sharkline has several wall closure systems, please follow the diagram that matches your pool*).

Type #1 Single Row

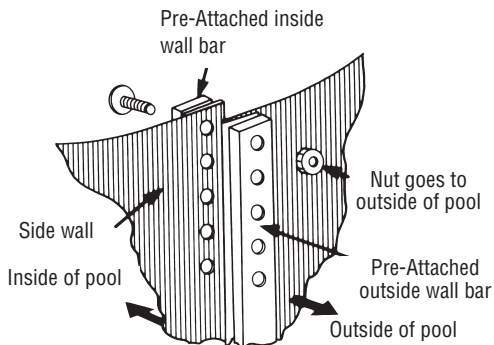

REMEMBER:

ALL HOLES AND BOLTS MUST BE USED ON 54" POOLS! 52" AND 48" POOLS MAY HAVE A FEW LEFT OVER. ALL NUTS SHOULD BE AS TIGHT AS POSSIBLE USING HAND TOOLS. BARS MUST NOT TOUCH EACH OTHER. IF THIS IS DONE INCORRECTLY YOUR POOL WILL BREAK!

Type #2 Staggered Bolt Pattern

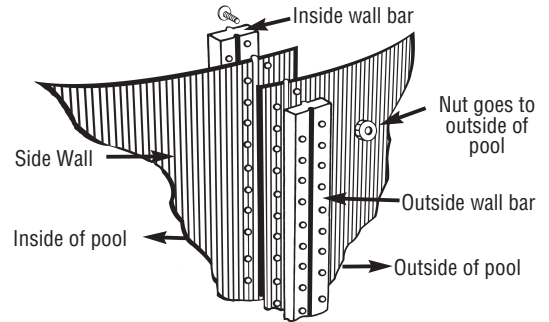

Top View

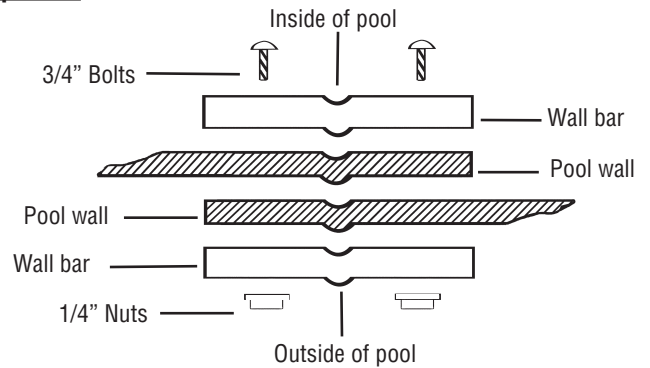

STEP 7: UPRIGHT INSTALLATION

Install uprights by simply lining the upright up to the three clips in the bottom cuff and pushing down until all three clips lock in. Once this is done correctly the upright should not pull up without bringing the bottom cuff and wall rims with it. Do this around the entire pool. When all uprights are attached check the pool for roundness again, making sure the diameter is the same in all directions.

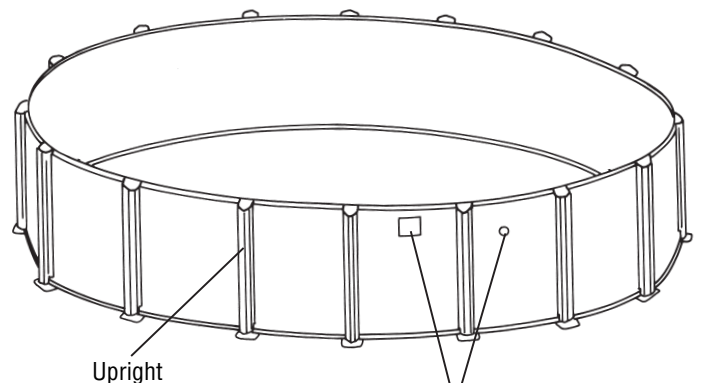
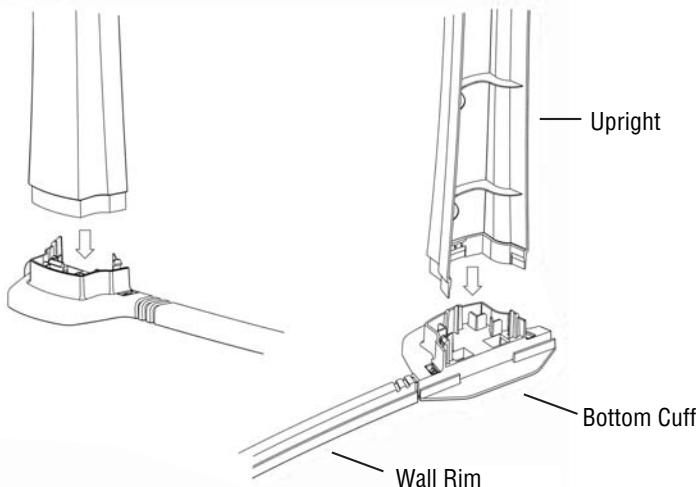

Note: Skimmer and skimmer return hole locations.

* Wall joint is hidden behind the upright. This assures that the skimmer and the skimmer return holes are not obstructed.

STEP 8: PREPARING THE COVE

Using neutral alkalinity sifted earth, or fine sand without pebbles, build a 2" base over the entire pool area to protect the liner. **DO NOT USE ANY SUBSTANCE WITH HIGH ALKALINE OR ACID CONTENT, ESPECIALLY PEAT MOSS, AS IT WILL CORRODE METAL PARTS!**

Next, using the sifted earth or fine sand, build a pool cove 6" to 8" high inside the wall along the entire circumference. This will prevent the liner from creeping under the wall, and it will also protect the liner from any edges of the pool framework. **THIS STEP IS NOT OPTIONAL- IT MUST BE DONE!** Since earth containing chemicals can cause discoloration or corrosion, it is suggested that you place polyethylene plastic sheeting under the cove around the perimeter of the wall, so no earth comes in contact with the metal wall. Since the presence of such chemicals is beyond the control of the manufacturer, such damage is not covered by the warranty.

After the cove and the base are in place, rake and tamp the entire pool area. Make sure that no sand is allowed to remain on the wall above the cove. This could cause pinholes in your liner.

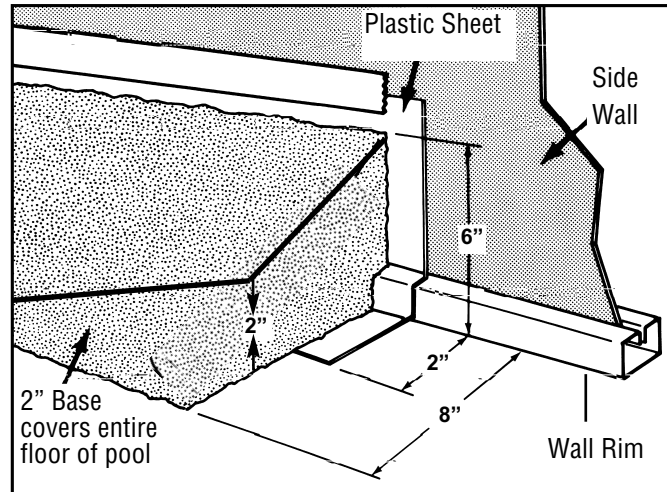

STEP 9: TOP WALL RIM INSTALLATION

When you are completely satisfied with the way that your liner is hanging, you can now permanently install the other half of your wall rims on the top of the pool, as shown in the diagrams. This is done by snapping one side of the wall rim into the clip on the top portion of the upright, inserting the wall into the slot in the wall rim, then snapping the other side of the wall rim into the clip on the top portion of the next upright over, and applying downward pressure with your hands until the rim is securely fastened over the coping that is holding your liner (note: if you have a J-Hook liner there is no coping so the wall rim will go directly over the bead of the liner). Continue this around the entire pool.

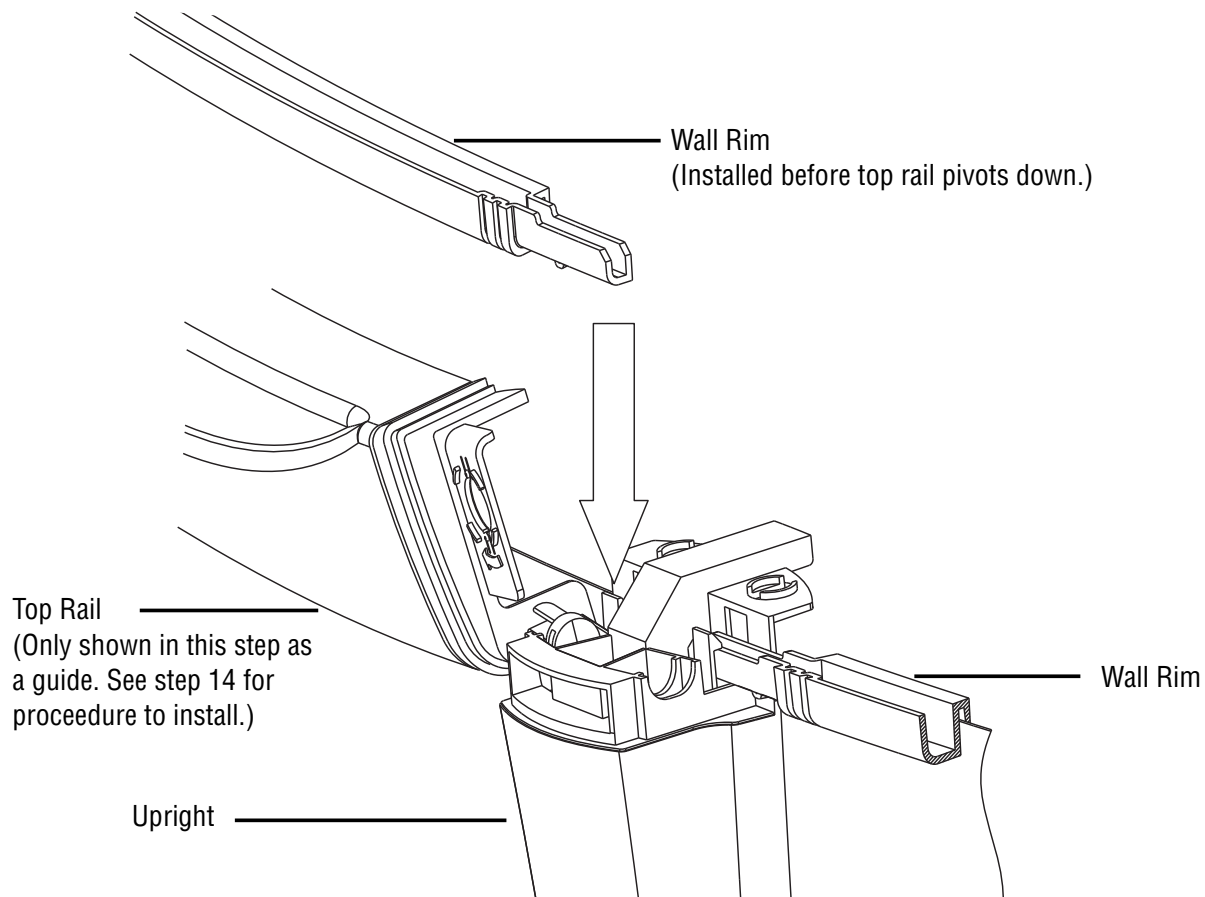

- **If you are using anything other than a beaded liner with your pool you must add this page to step 13 of your pool instructions.**

After you have installed all of your wall rims around the top of the pool, you will see that there is a space under each upright where there is no wall rim. It is in those places where you need to install your wall rim spacers.

The wall rim spacers are installed by placing each piece under and upright, between the two wall rims, and pushing them down over the coping (as shown in the diagram.) Be sure that the hollow side of the wall rim spacer is on the inside of the pool wall.

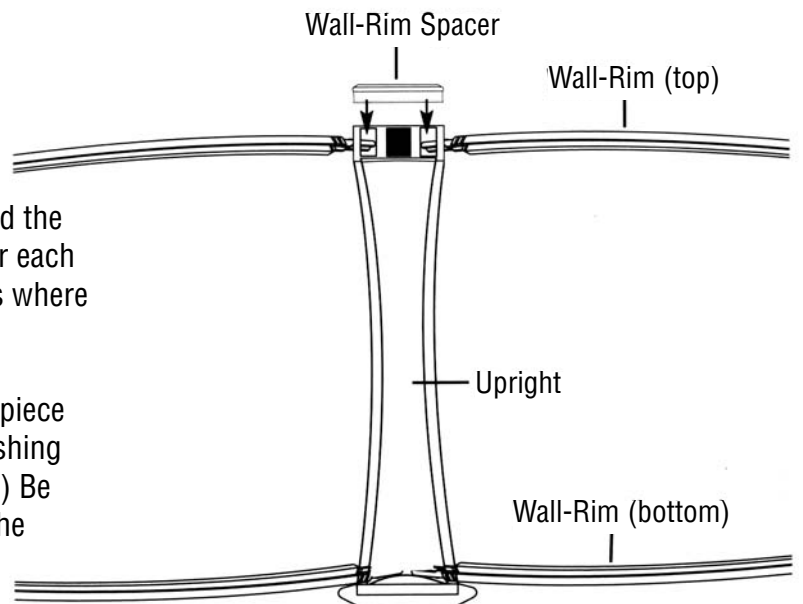

STEP 10: INSTALLING THE TOP CAPS

Center a top cap on each upright one at a time. Angle the front of the cap (the wider half of the cap which goes to the inside of the pool) down towards the floor of the pool and clip it to the inside of the upright. Pull down and back until the cap clips onto the back (or outside) of the upright. The top cap should now be secure and flush with the top rails. If it is not, pull the cap off and try it again. The caps should fit on easily and should not require excessive force to snap into place.

Continue around the entire pool until the joint at each upright is covered. Once that is done the installation of your pool is complete. Be sure to remove all stakes that were holding the bottom ring at this time, if you have not already done so. **Congratulations and enjoy your pool safely!**

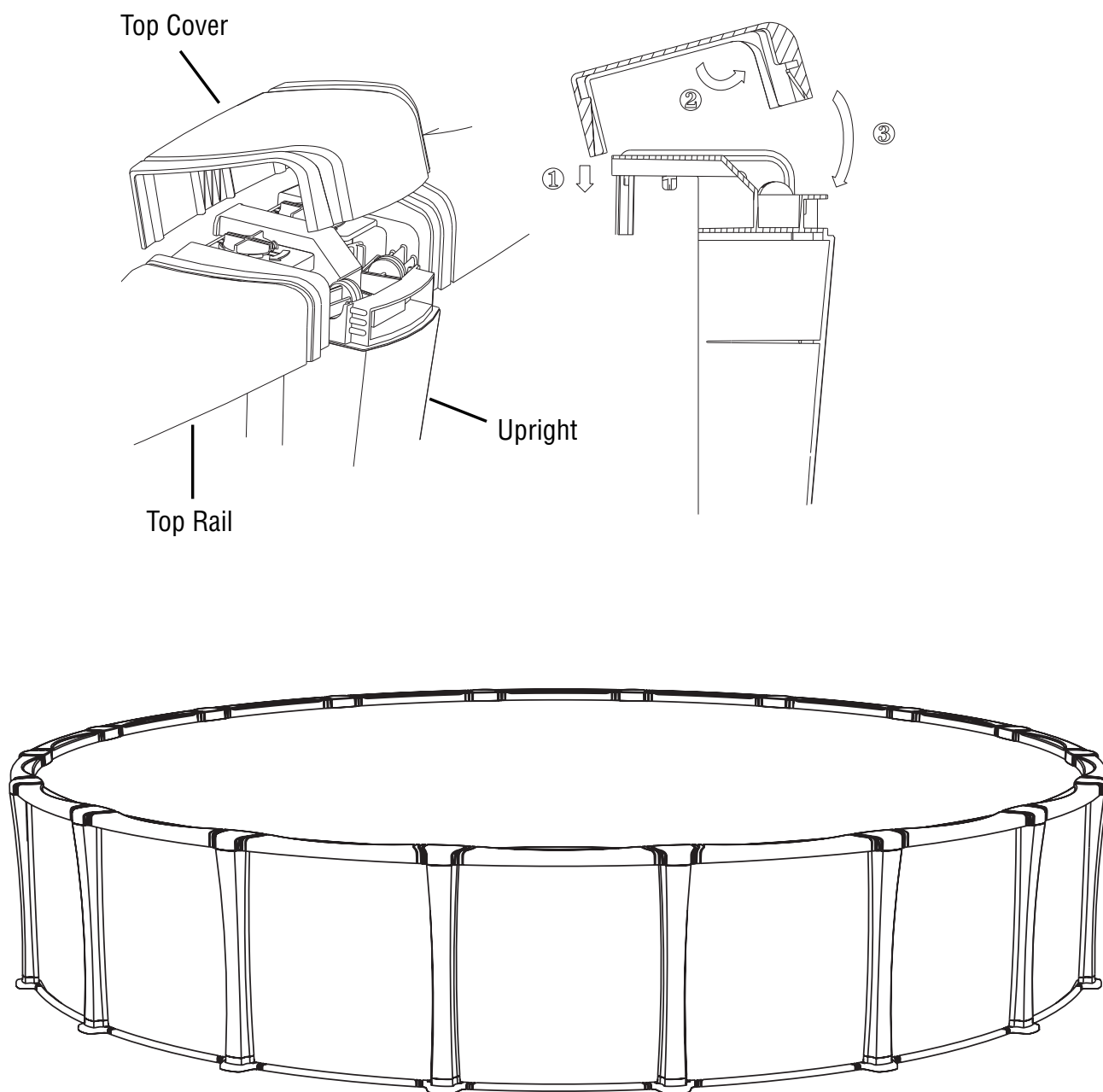

IMPORTANT INFORMATION:

*Please fill out this sheet and keep it in your records for future reference. This information can be very helpful if the time ever comes that you need to make a warranty claim, change your liner, or need replacement parts for your swimming pool.

1) Name of Pool _____

2) Date of Pool Purchase _____

3) Purchased From _____

4) Date Installed _____

5) Installed By _____

6) Size of Pool _____

7) Name of Pool Wall _____

8) Kind of Skimmer Used (circle one): Wide Mouth Skimmer Standard Skimmer

9) Kind of Base Used _____

10) Name & Manufacturer of Liner _____

** If you do not know the answers to any of the above please see your dealer and they will help you.

ADDITIONAL NOTE:

If you live in an area where you need to close your pool during the winter months, it is important that you know that all Sharkline warranties specifically exclude any kind of winter damage. This includes damage caused by winter covers.

Even though most winter covers include a cable to secure them, we do warn you that this may not be the best way to attach them to our pools. Cables on winter covers can cause damage to resin pools, coatings on metal components of pools, pool liners, and resin top covers.

Sharkline believes it to be much better for the well being of your pool if the winter cover is held in place by hanging weights or by being staked to the surrounding ground. Whether it be milk jugs full of water or something more sophisticated, this is likely to prolong the life of your pool.

It is also important to make sure that there is never too much stress on a winter cover. Any excessive snow or ice build up on a winter cover can also damage an above ground pool. Such damage is not covered by Sharkline so please be sure to clear away any such accumulation from your winter cover before this kind of damage occurs.