



BIKE HOME ASSEMBLY GUIDE

WARNINGS AND SAFETY INSTRUCTIONS

Read all warnings and instructions before beginning to assemble the Peloton Bike. Assemble the Bike according to the procedures described in this guide. Peloton is not responsible for damage, injury, or equipment failure caused by improper assembly or use.

This is an assembly guide and does not contain instructions for using the Peloton Bike. Do not operate the Bike before reading the Peloton Bike User Manual for full safety information and usage instructions. Use only as described.

It is the owner's responsibility to ensure that all users are aware of all warnings and precautions.

Keep children and pets away from the Bike at all times.

The Bike and Bike package are extremely heavy and require more than one person to lift or carry. Lifting heavy objects can cause muscle strain and back injuries, and heavy objects can fall and cause injury and physical damage. Use lifting aids and proper lifting techniques when moving or assembling the Peloton Bike. A second person may be helpful when raising and lowering the Bike.

Perform a complete visual inspection of the Peloton Bike and test all features and functions prior to use.

SAVE THESE INSTRUCTIONS FOR FUTURE USE.

GETTING READY

- A** Touchscreen
- B** Handlebars
- C** Handlebar Post
- D** Resistance Knob / Emergency Brake
- E** Handlebar Height L-Handle
- F** Water Bottle Holder
- G** Flywheel
- H** Wheels
- I** Front Stabilizer
- J** Power Supply
- K** Pedals
- L** Rear Stabilizer
- M** Leveling Feet
- N** Crank Arms
- O** Seat Height L-Handle
- P** Seat Depth L-Handle
- Q** Weight Holders
- R** Saddle

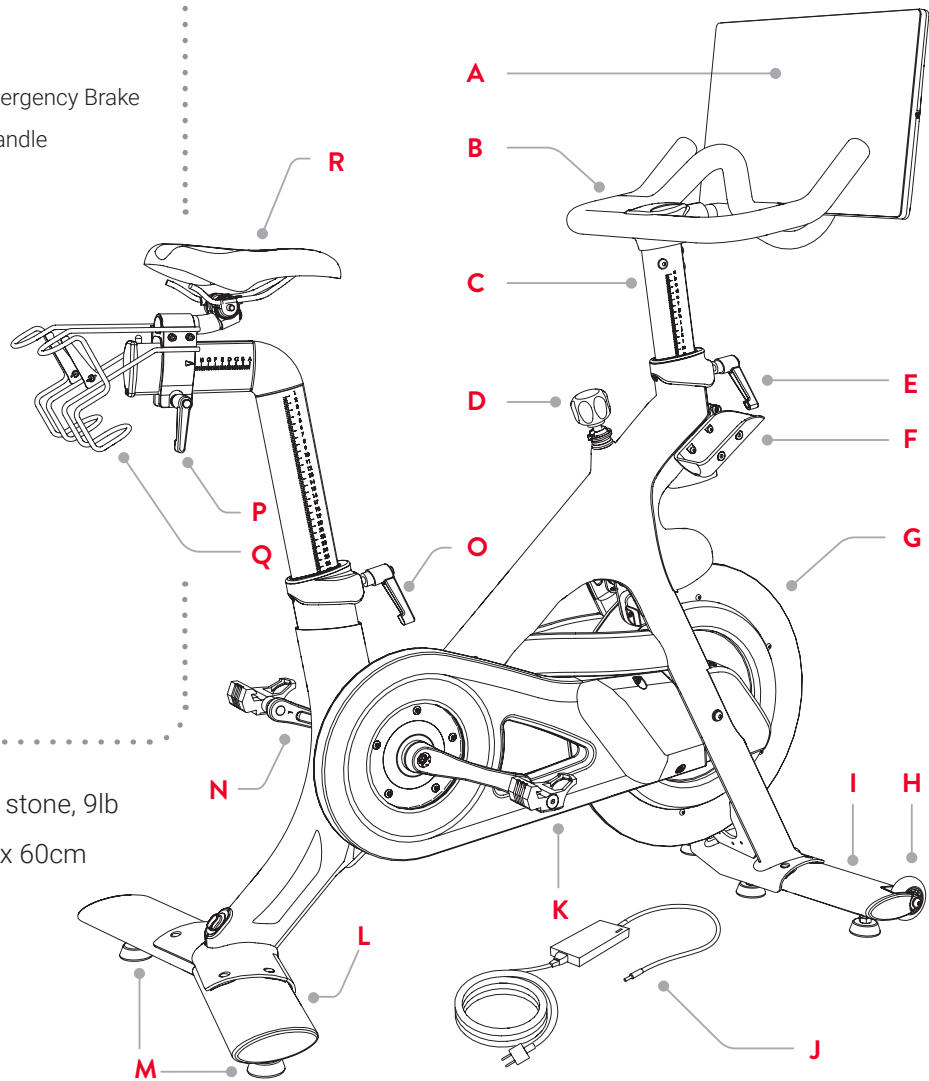

Bike weight: 135lb/61kg/9 stone, 9lb

Footprint: 4ft x 2ft/120cm x 60cm

US



UK



VIDEO INSTRUCTIONS

Scan the QR code or go to onepeloton.com/setup/bike to access the latest instructions, including an assembly video.

GETTING READY

PREPARE YOUR WORKSPACE

⚠ CAUTION: The Bike and Bike package are extremely heavy and require more than one person to lift or carry.

- Find a location for your Bike. Peloton recommends assembling the Bike on a solid, level surface in the same space where it will be used, to limit movement after assembly. Refer to the Bike User Manual for location requirements.
- Clear a 5 ft by 5 ft space for assembly.
- Locate a pair of scissors or a similar tool. The Bike includes all the tools you will need for assembly, but you will need scissors to unpack it.
- We recommend having a second person assist with assembly.

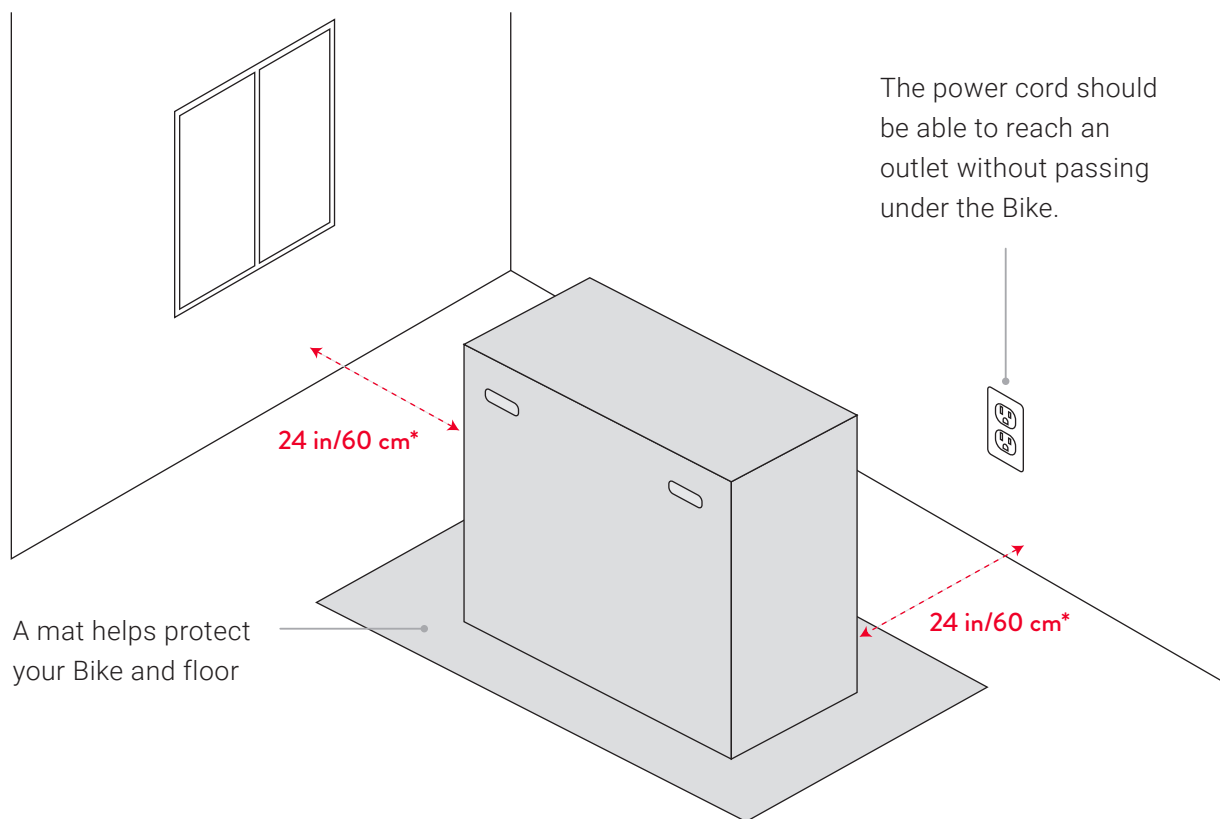

⚠ CAUTION: Ensure that the power cable never passes under the bike. Always keep the power cable clean and dry. Sweat, spills, and other damage to the power cable may result in property damage or bodily harm.

* There should be 24 in/60 cm of empty space on each side of the assembled bike.

GETTING READY

UNPACK YOUR BIKE

- 1 Open the outer carton. Inside, find the inner bike carton, the home assembly kit, and the touchscreen box. Clear away the rest of the cardboard, but leave the unfolded outer carton under the Bike—it will protect the Bike and your floor during the assembly process.

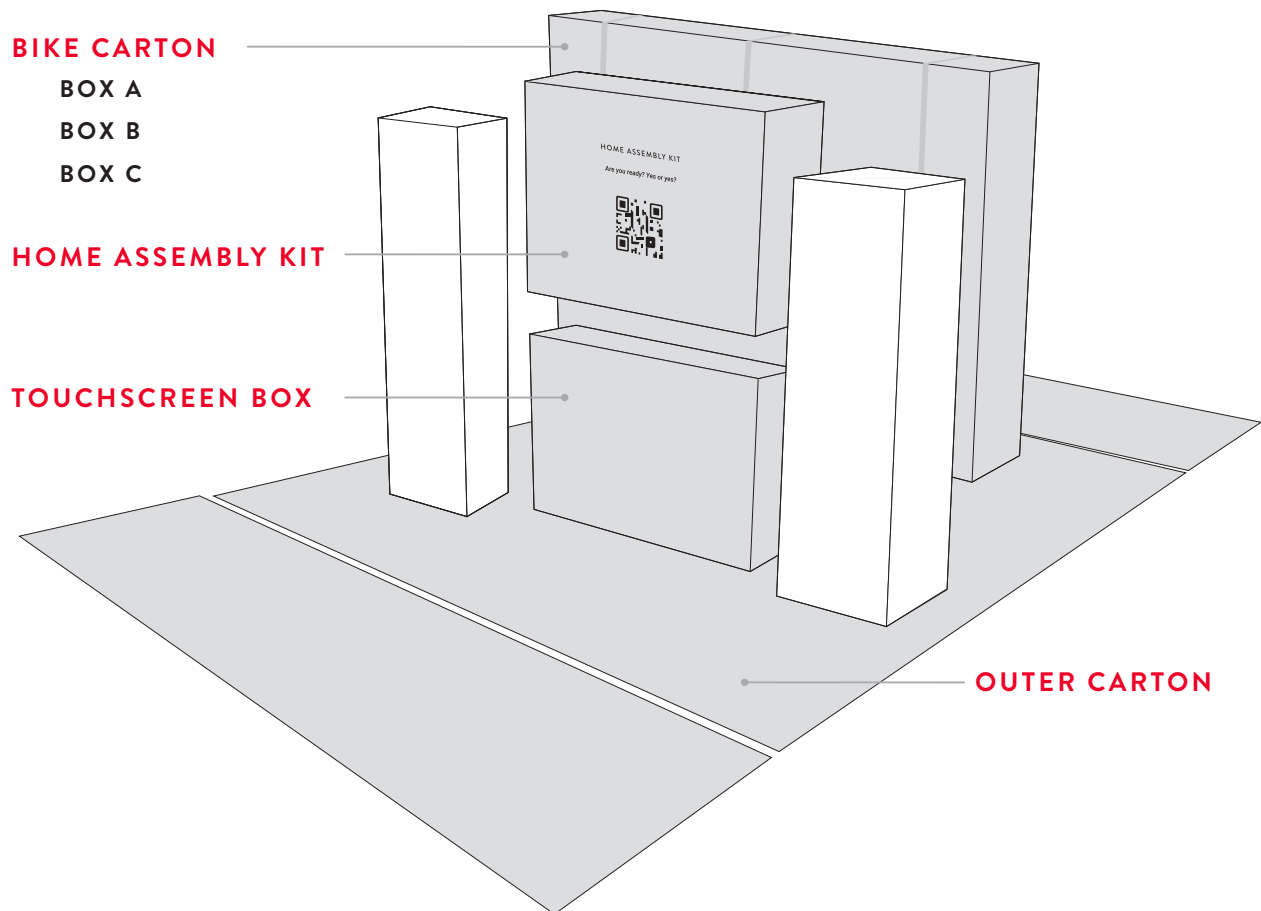

- 2 Using a pair of scissors, cut the (3) plastic straps on the inner carton.
- 3 Lift the carton lid off the base. It should slide off easily.

GETTING READY

- 4 Find and set aside boxes A, B and C.
- 5 Clip the zip ties on the frame and remove the handlebars and monitor arm.
- 6 Remove the remaining packaging materials from the carton.

BIKE CARTON

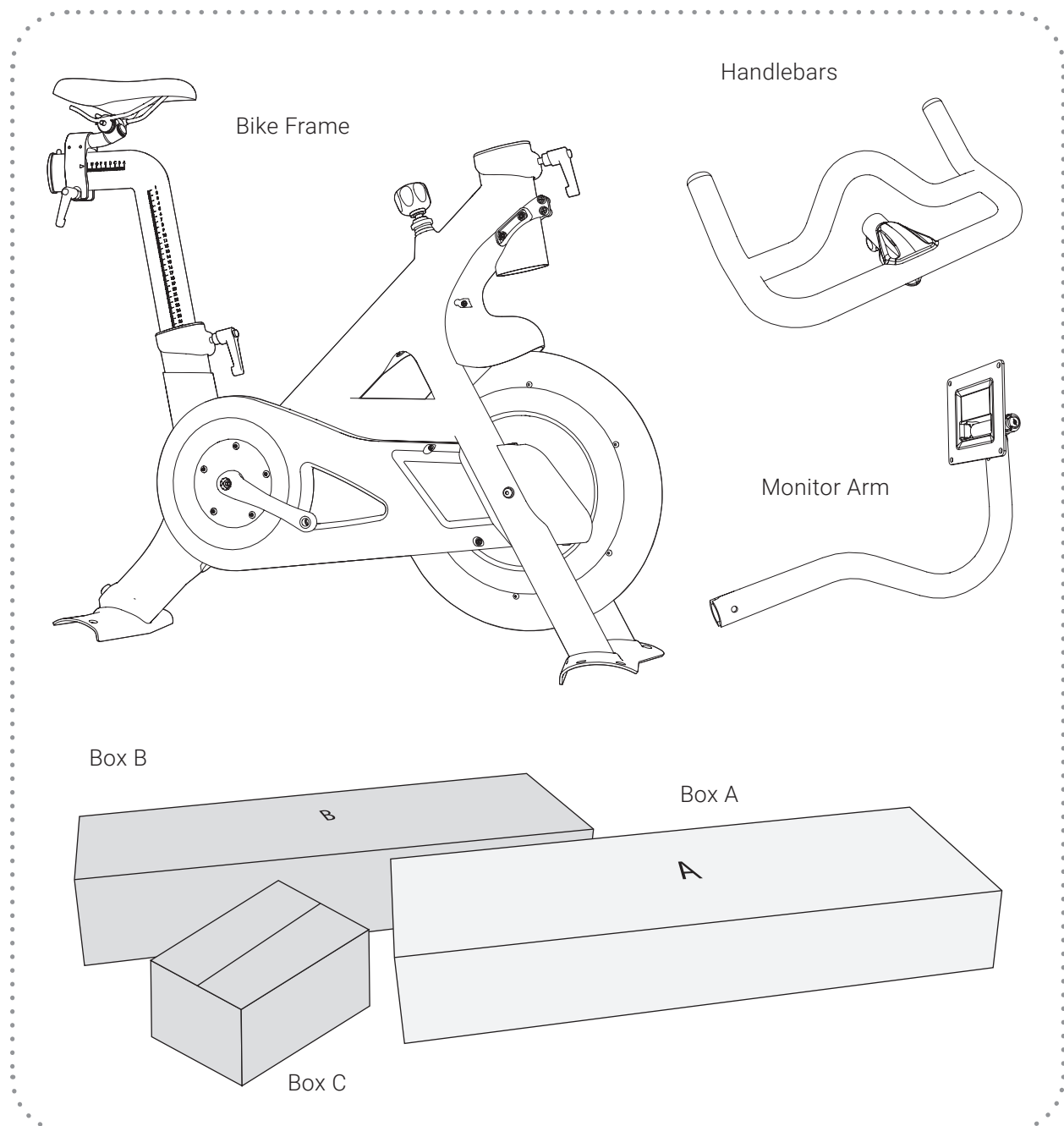

GETTING READY

IDENTIFY PARTS

Before beginning to assemble your Bike, locate and identify all parts and tools.

HOME ASSEMBLY KIT

Bike Assembly Guide Cardboard Stabilizer Insert Long Allen Wrenches Pedal Wrench

3mm 5mm

BAG 1

A **B** **C**

8x 2x 2x

BAG 2

C **D** **E** **F**

2x 2x 1x 4x

BAG 3

J

4x

BOX A

Front Stabilizer

WEIGHT HOLDER KIT

Left weight holder Right weight holder

Bolt G **Washer H** **Washer I**

4x 4x 4x

BOX B

Rear Stabilizer

Handlebar Post

GETTING READY

BOX C

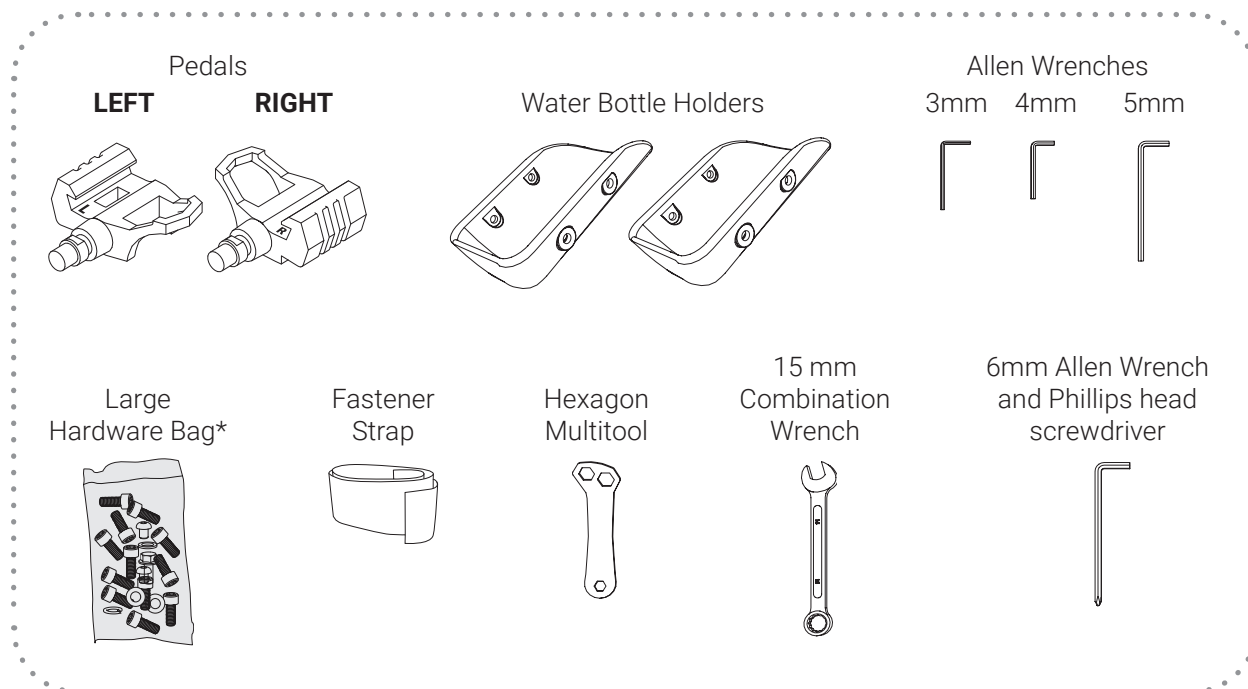

* The large hardware bag in Box C contains the same bolts and washers as hardware bags 1 & 2. You shouldn't need it to assemble your Bike, but if you need a spare bolt or washer, you can find it here.

TOUCHSCREEN BOX

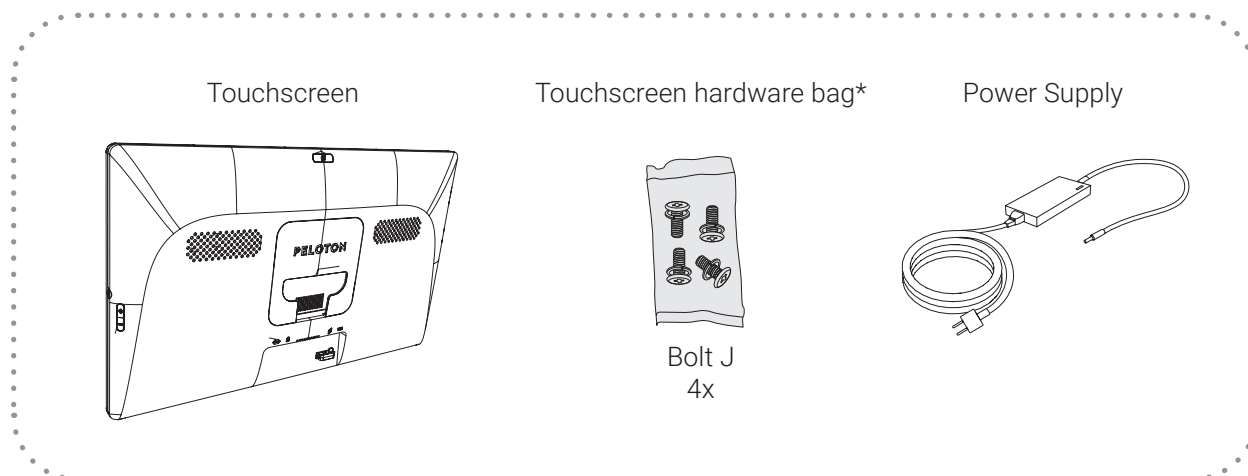

* The bolts in the touchscreen hardware bag are duplicates of the ones in hardware bag 3. You won't need them to assemble your Bike, but if you need a spare you can find it here.

The touchscreen hardware bag may be taped to the inside of the touchscreen box or included in a box containing the power supply.

ASSEMBLING THE BIKE

REMOVING THE BIKE FROM THE CARTON

- 1 Make sure the L-handles at the front of the Bike and seat tube point straight down. If either L-handle sticks out sideways, pull the handle out and rotate it to point down.

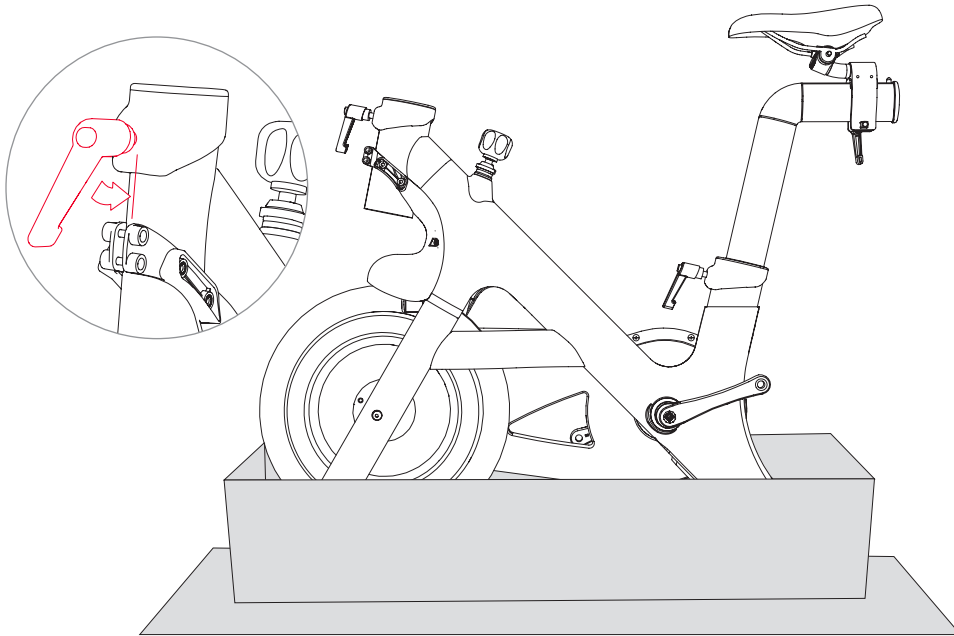

- 2 Fit the cardboard stabilizer insert onto the frame as shown. Make sure it sits flush against the flywheel.

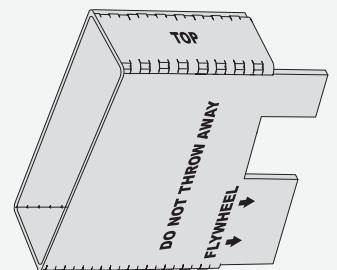
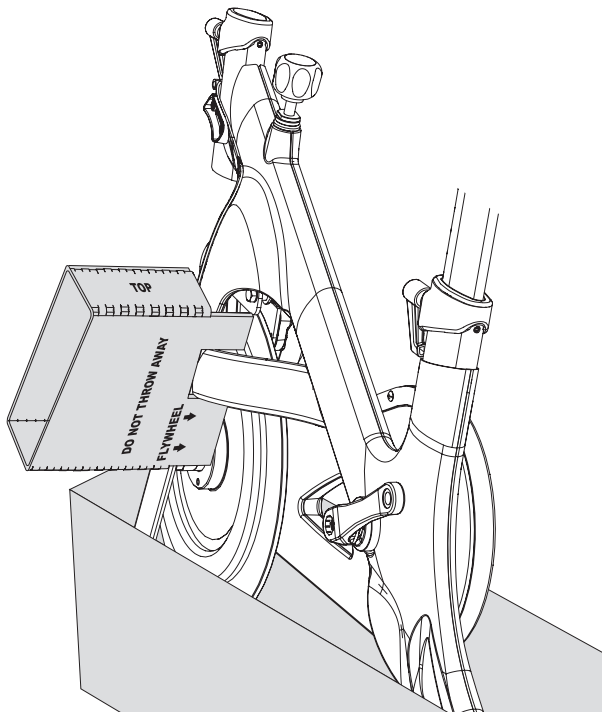

ASSEMBLING THE BIKE

⚠ **CAUTION:** Lifting heavy objects can cause muscle strain and back injuries, and heavy objects can fall and cause injury and physical damage. Use lifting aids and proper lifting techniques when moving or assembling the Peloton Bike. A second person may be helpful when raising and lowering the Bike.

- 3 Slowly lower the Bike onto its left side. Make sure the stabilizer insert stays in place and rests flat against the floor.

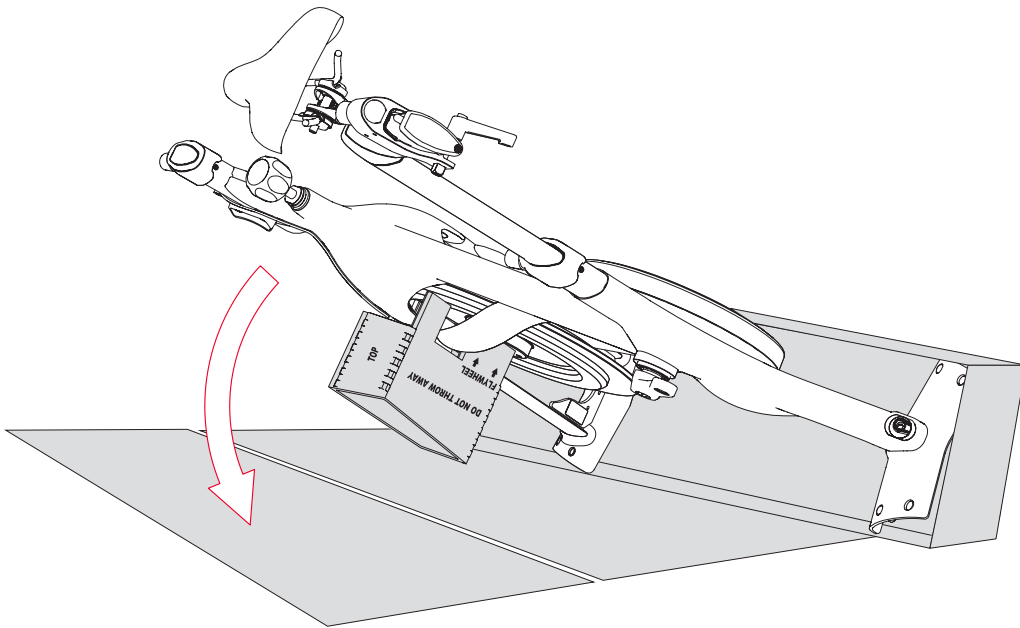

- 4 Remove the carton base from the bottom of the Bike.

ASSEMBLING THE BIKE

ADDING THE STABILIZERS

- 1 Fit the front stabilizer tightly against the front foot of the Bike.

Note: Make sure you have the correct stabilizer. The front stabilizer has wheels and the rear stabilizer does not.

- 2 Using the 6mm Allen wrench and **(4)** bolts **A**, secure the front stabilizer to the foot of the Bike. Make sure you fully tighten all four bolts.

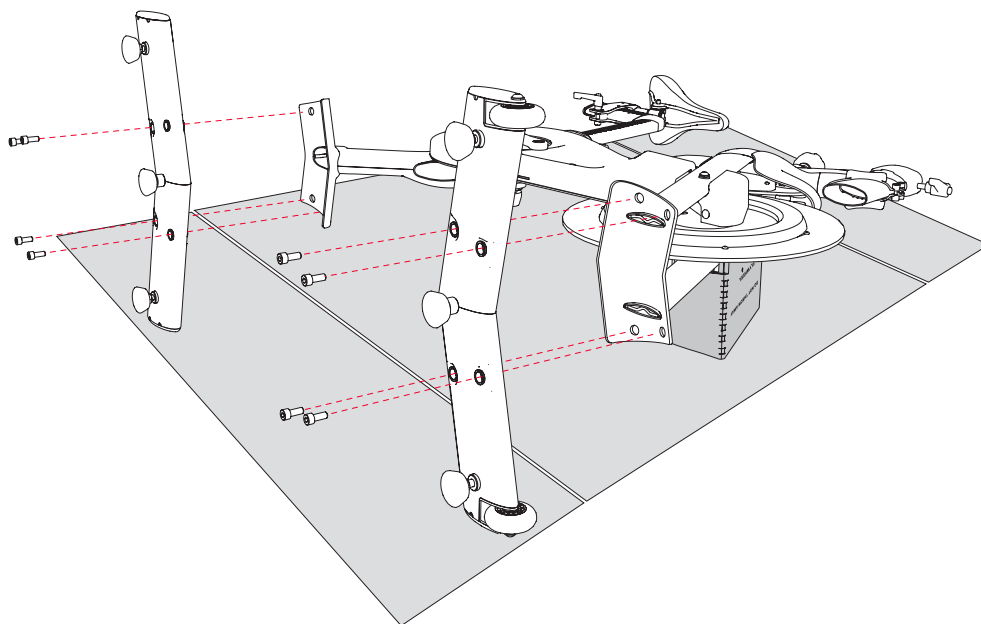

- 3 Fit the rear stabilizer onto the back foot of the Bike.

- 4 Using the 6mm Allen wrench and **(4)** bolts **A**, secure the back stabilizer to the foot of the Bike. Make sure you fully tighten all four bolts.

⚠ CAUTION: Make sure all bolts are tight before moving to the next step. Shake each stabilizer to make sure it is held securely against the frame. If there is any movement, tighten each bolt again.

- 5 Carefully lift the Bike and set it upright.

PARTS AND TOOLS

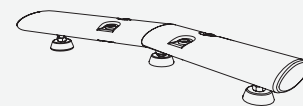
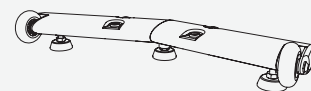

ASSEMBLING THE BIKE

ASSEMBLING THE HANDLEBARS

- 1 Fit the handlebar post onto the handlebar base. Make sure the letters on the post will be upright when the handlebars are right-side up.
- 2 Add two washers **C** and two bolts **B** to the front of the handlebar base. Screw them in using your 5mm Allen wrench.
- 3 Add two flat washers **C** and two bolts **D** to the sides of the handlebar base. Screw them in using the 5mm Allen wrench.

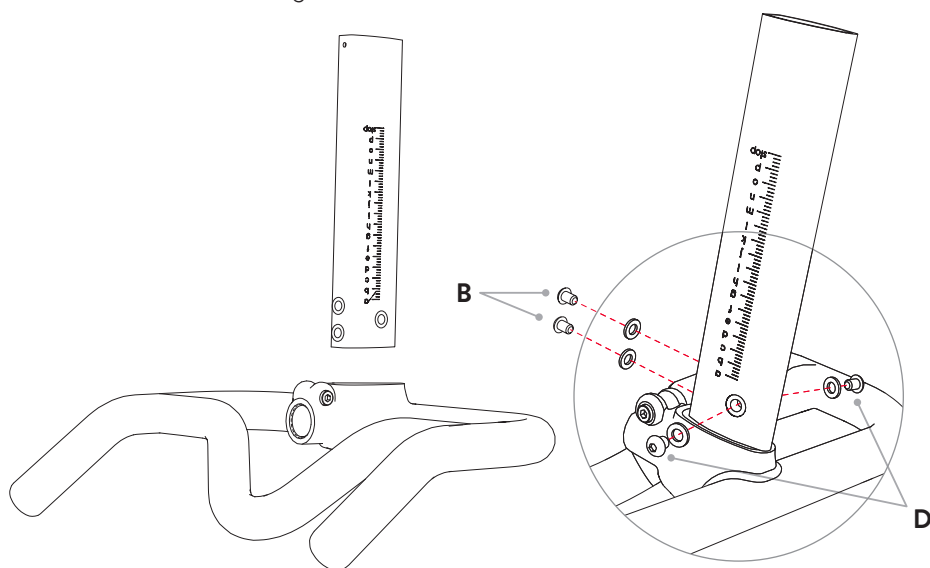

- 4 Loosen the L-handle at the front of the Bike by turning it counterclockwise. Insert the handlebar post into the head tube and move it to its lowest position—you'll need access to the bottom of the post.

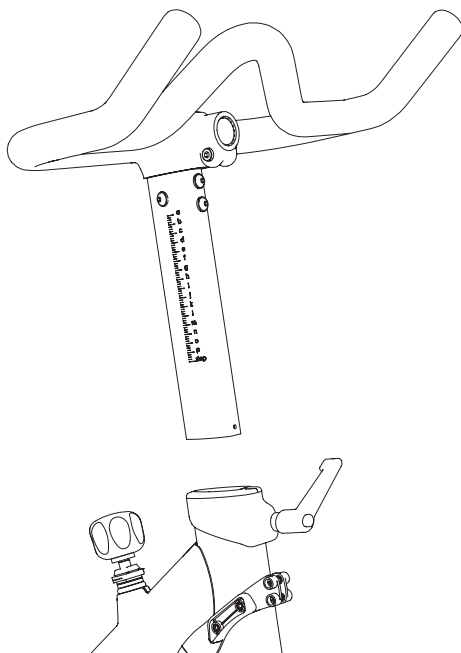

PARTS AND TOOLS

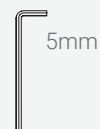
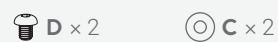
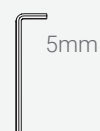
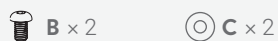
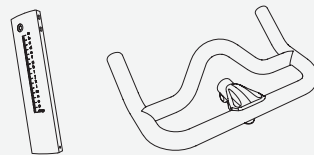

Having trouble inserting the handlebar post?

A plastic clip inside the head tube may be getting in the way. Reach into the head tube and press both sides of the clip flat.

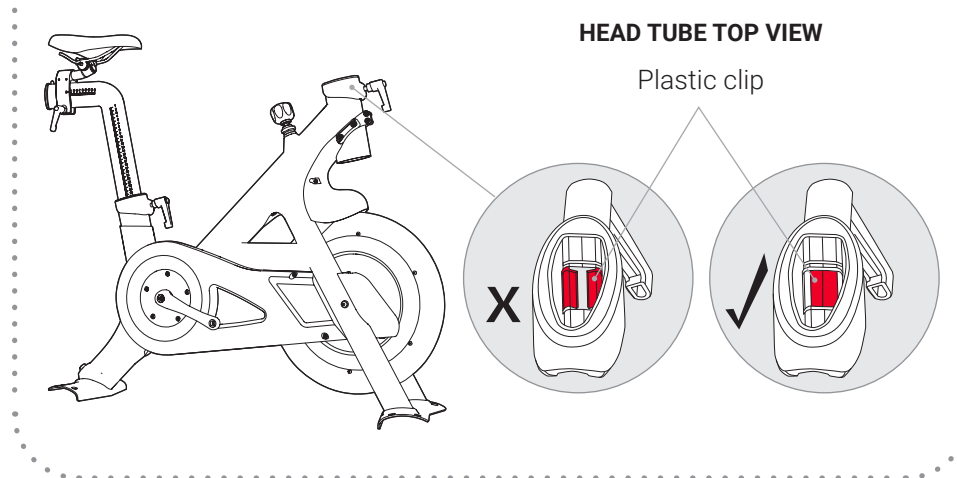

- 5 Add bolt **E** to the end of the handlebar post. Screw it in using a Phillips head screwdriver.

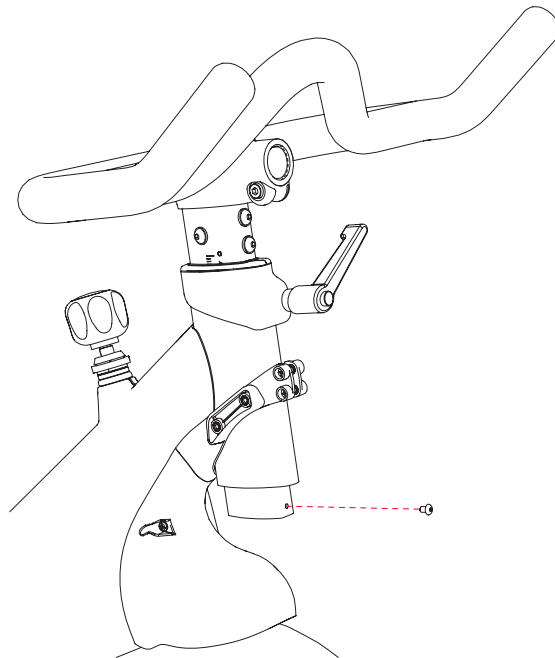

- 6 Tighten the L-handle and wiggle the handlebars. Any movement could mean that the bolts aren't fully tight. Then move the handlebars to the highest position and perform the same check.

CAUTION: Make sure all bolts are tight before moving to the next step. If there is any movement when you wiggle the handlebars, tighten each bolt again.

ASSEMBLING THE BIKE

ADDING THE WATER BOTTLE HOLDERS

- 1 Fit one water bottle holder against the side of the front shroud.* Attach it using two bolts **F** and the long 3mm Allen wrench from the Home Assembly Kit. Fit the Allen wrench through the outer openings in the water bottle holder for easier access to the bolts.

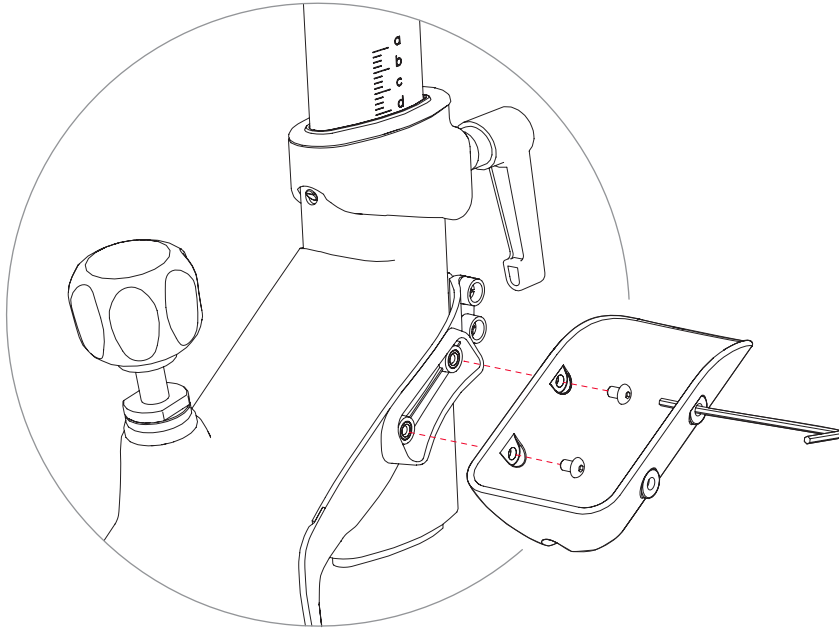

- 2 Using the remaining two bolts **F**, attach the second water bottle holder to the other side of the shroud.

*The two water bottle holders are identical, so you can use either one on either side of the Bike.

PARTS AND TOOLS

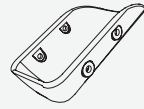

F × 2

Long 3mm

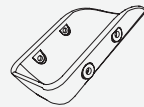

F × 2

Long 3mm

ASSEMBLING THE BIKE

INSTALLING THE PEDALS

⚠ CAUTION: Identify the right and left pedals before beginning installation. Make sure each pedal is correctly threaded before screwing it in. Misaligning the threads or turning a pedal in the wrong direction could lead to injury and damage the pedal and Bike.

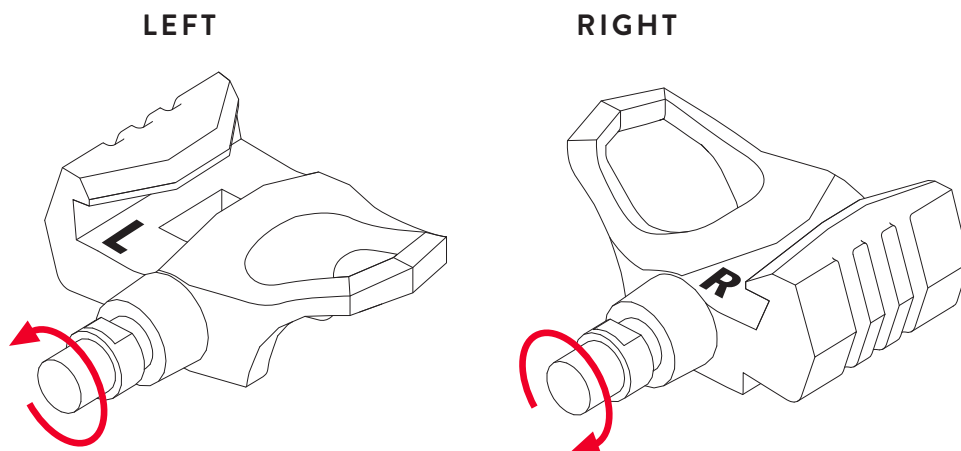

- 1 Rotate the crank arms until both are parallel with the floor. Then turn the resistance knob all the way clockwise to lock the flywheel.

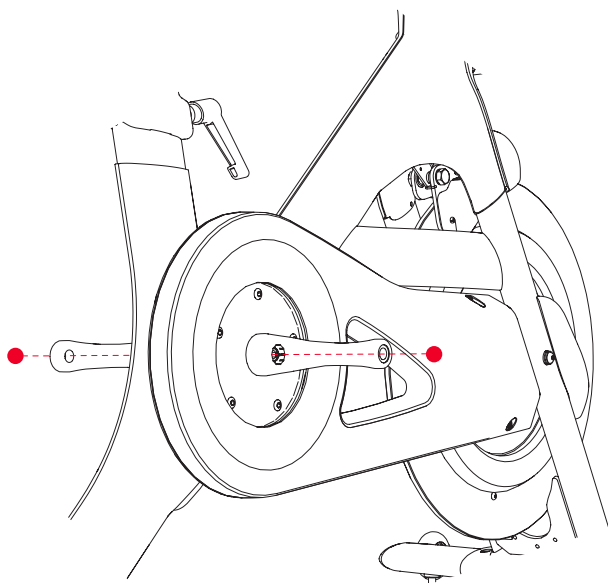

ASSEMBLING THE BIKE

PARTS AND TOOLS

- 2 Screw in the right pedal. You may need to turn it slightly counterclockwise to seat it. Then hold the pedal steady and turn the axle **clockwise** to tighten it.
- 3 Screw in the left pedal. You may need to turn it slightly clockwise to seat it. Then hold the pedal steady and turn the axle **counterclockwise** to tighten it.

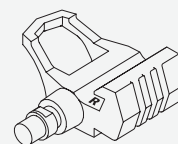
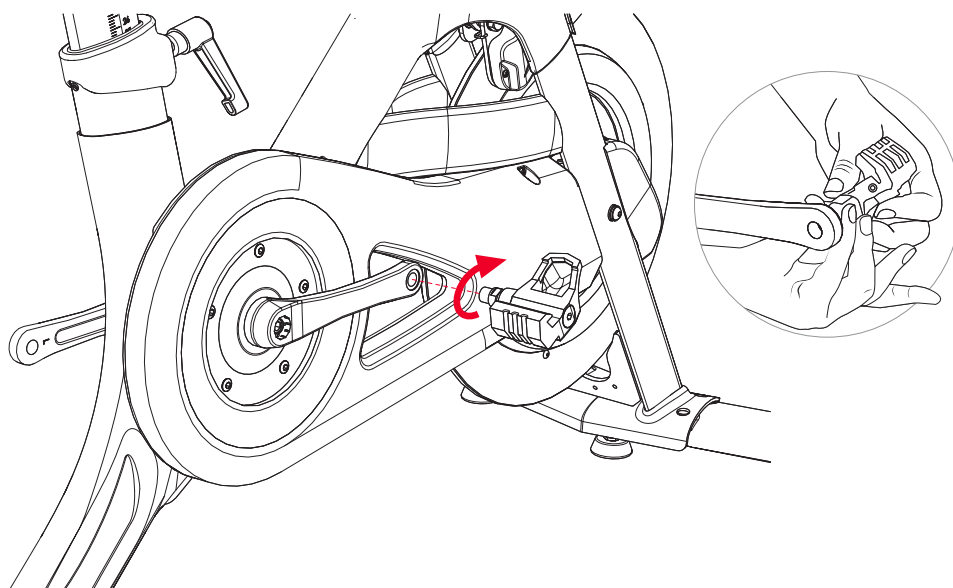

RIGHT

NOTE: The pedals are marked R and L for right and left. Make sure you know which one is which. The left pedal is reverse-threaded, so both pedals tighten when turned towards the front of the Bike.

- 4 Once both pedals are hand-tight, use your pedal wrench to fully tighten them. Remember to turn the wrench toward the front of the Bike on both sides.

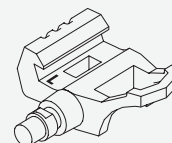
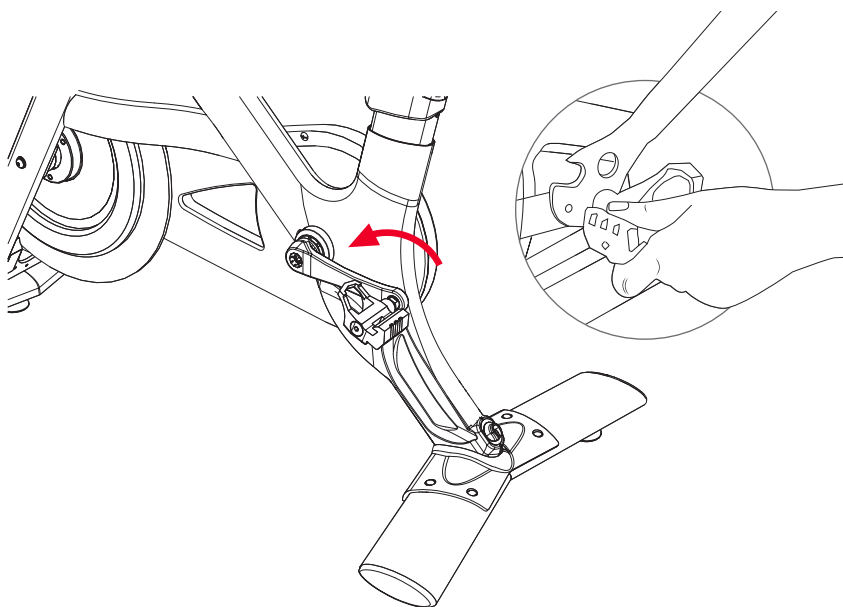

LEFT



ASSEMBLING THE BIKE

ADDING THE WEIGHT HOLDERS

- 1 Make sure the L-handle under the seat points straight down. If it's pointed up, pull the handle out and rotate it to point down.
- 2 Locate the **(4)** bolts **G**, **(4)** flat washers **H**, and **(4)** spring washers **I**. Add one spring washer and one flat washer to each bolt.

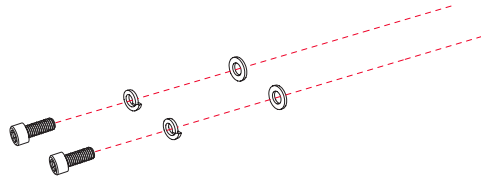

- 3 Identify the left and right weight holders. Hold the right weight holder against the right side of the seat slider and secure it using your 4mm Allen wrench and two bolts with washers.

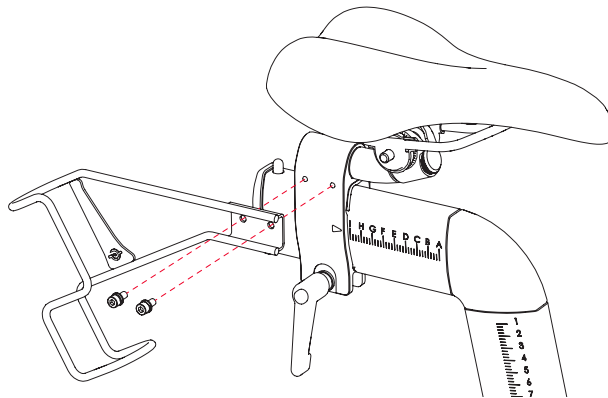

- 4 Add the left weight holder to the left side of the seat slider using the remaining two bolts with washers.

- 5 Check both weight holders to make sure that all bolts are tight and both weight holders are firmly attached to the seat slider.

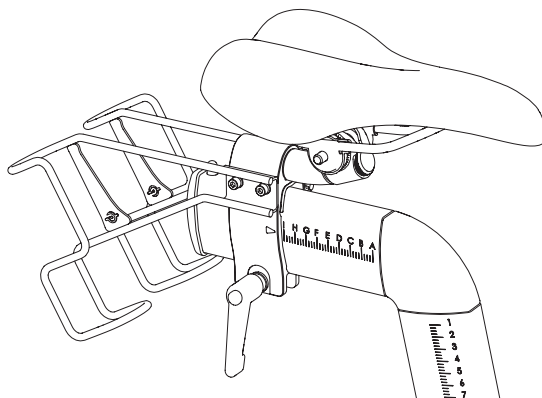

PARTS AND TOOLS

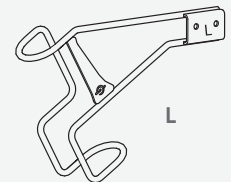
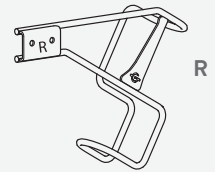
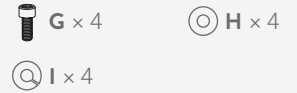

ASSEMBLING THE BIKE

PARTS AND TOOLS

ATTACHING THE TOUCHSCREEN

- 1 Carefully lay the touchscreen face down on a towel or mat. Remove the square panel from the back of the touchscreen.

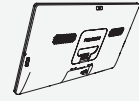
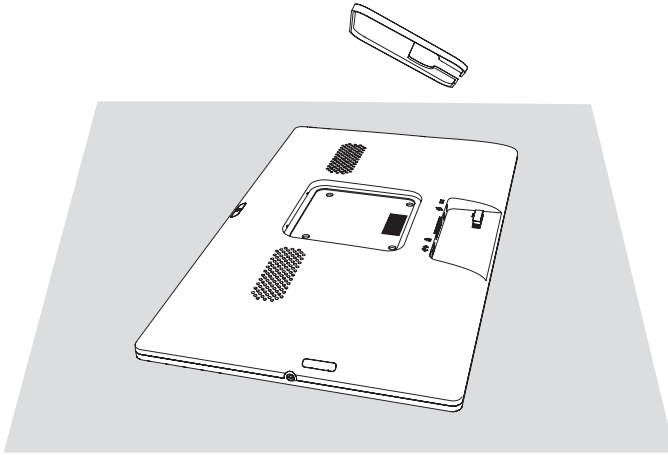

- 2 Set the mounting plate perpendicular to the monitor arm.

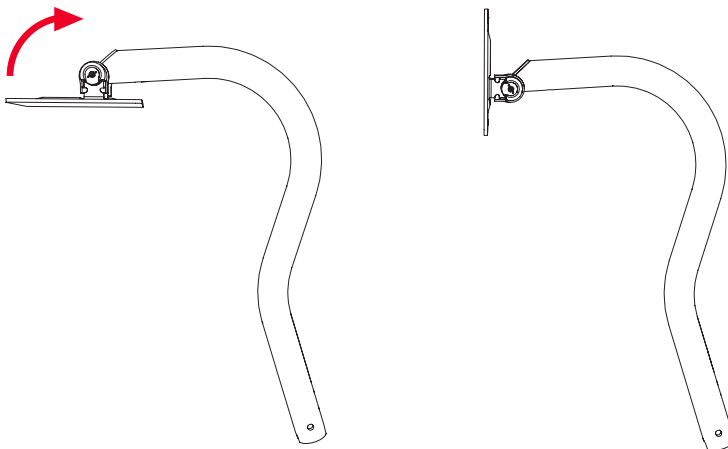

Having trouble turning the mounting plate?

- Snap the plastic caps off the mounting plate hinge.
- Use the hexagon multitool to hold the nut in place. Then use the 6 mm Allen wrench to rotate the bolt about one half-turn counterclockwise.
- Test the hinge again. You should be able to move it, but it should still be stiff enough to hold the weight of the monitor without moving. If you're still having trouble moving it, continue to loosen in half-turn increments.
- When you're done, snap the plastic caps onto the hinge again.

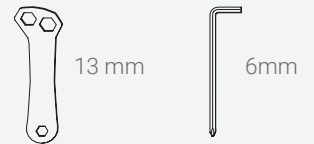
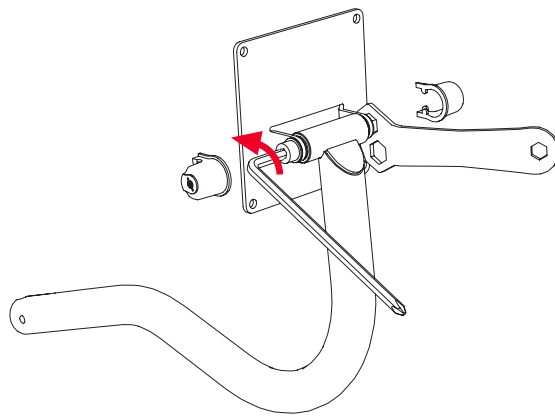

- 3** Align the plate with the screw holes on the back of the touchscreen. Secure the touchscreen to the monitor arm using your Phillips head screwdriver and **(4)** bolts **J** with washers.

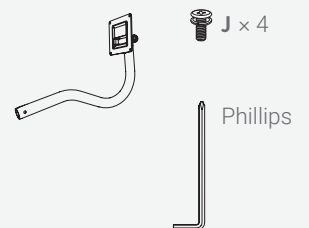
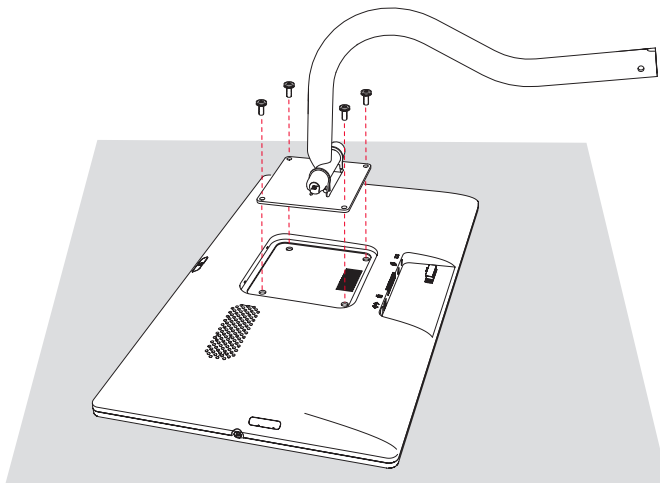

- 4 Snap the square panel back onto the touchscreen.
- 5 Insert the monitor arm into the handlebar base. Push it in as far as it will go and make sure the touchscreen is fully upright.

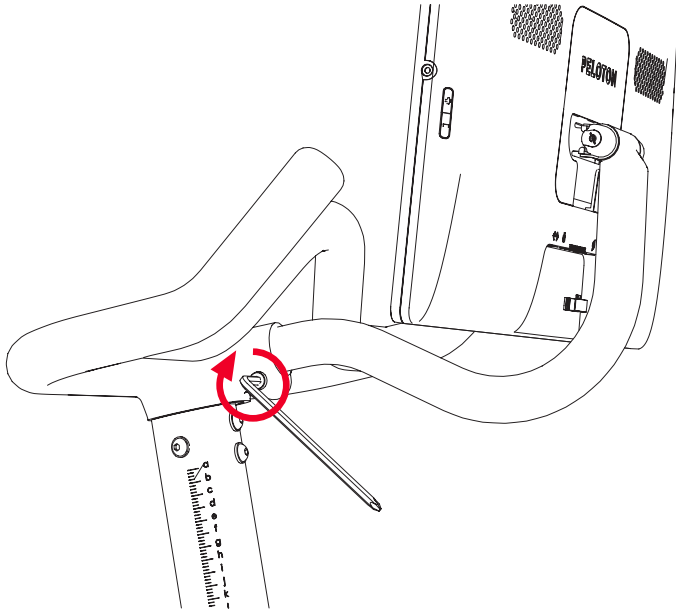

- 6 Tighten the bolt at the side of the handlebar base using your 6mm Allen wrench.

⚠ CAUTION: Make sure all bolts are tight before moving to the next step. Tilt the touchscreen forward and back to check for wobble between the touchscreen and mounting plate. If there is any movement, tighten each bolt again.

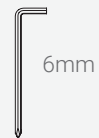

ASSEMBLING THE BIKE

PARTS AND TOOLS

CONNECTING THE TOUCHSCREEN

- 1 Open the plastic clamp at the back of the touchscreen. This may require some force.
- 2 Locate the monitor cable at the left of the flywheel. Plug the cable connectors into the power and data ports. Make sure both connectors are fully seated, then close the clamp.

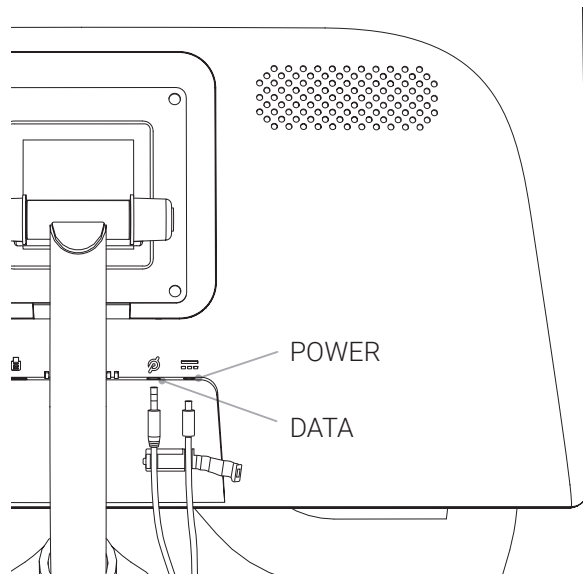

- 3 Using the fastener strap, secure the cable to the monitor arm. Make sure there is enough slack on both sides of the strap to raise the handlebars to their highest position and to tilt the touchscreen up and down.

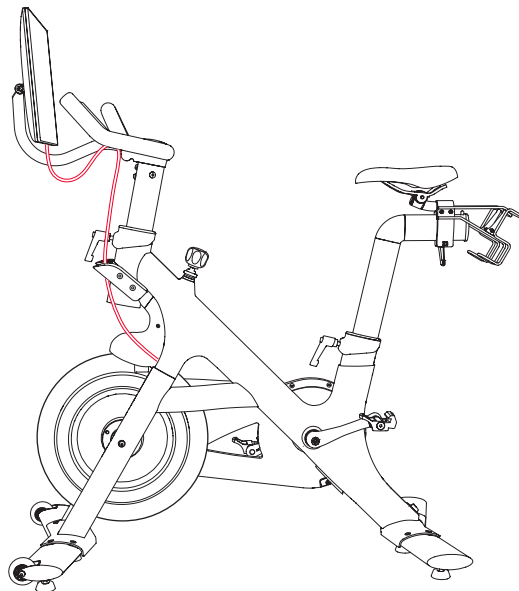
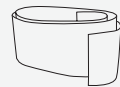

⚠ CAUTION: Make sure that the monitor cable sits clear of the flywheel and brake assembly. Contact with moving parts could damage the cable.

ASSEMBLING THE BIKE

PARTS AND TOOLS

LEVELING THE BIKE

- 1 Gently push the seat and handlebars from side to side to check if the bike rocks or wobbles.
- 2 If there is any wobble, check each of the four leveling feet. If any foot does not rest firmly against the floor, turn it clockwise to lower it. Note that the center foot on each stabilizer cannot be adjusted.

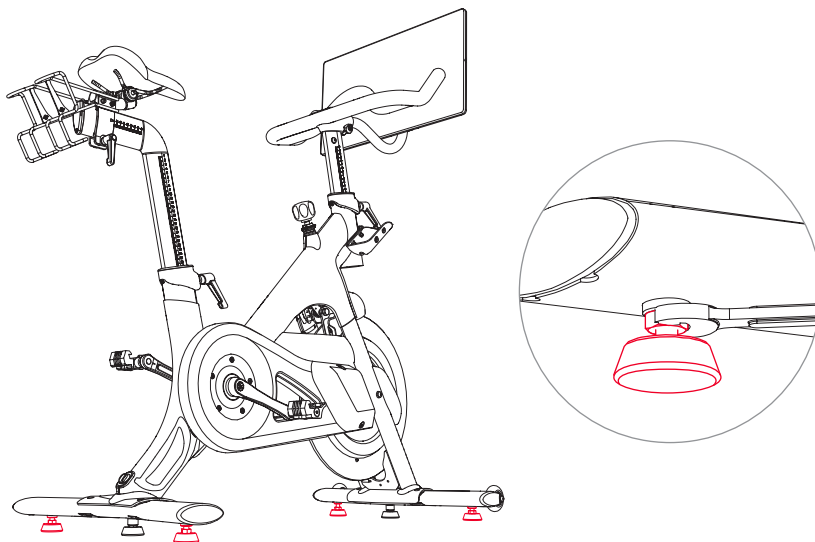

- 3 Using the 15 mm wrench, tighten the nut on each leveling foot. The nut should sit against the underside of the stabilizer.



15 mm

PLEASE SEE THE PELOTON BIKE USER MANUAL FOR NEXT STEPS, INCLUDING PLUGGING IN THE POWER CORD, ADJUSTING THE BIKE TO FIT YOUR BODY, AND CONNECTING YOUR PELOTON ACCOUNT.



© Peloton 2022, Peloton Interactive, Inc. All rights reserved.

onepeloton.com

PL-01 | PL-21 | 40008795-2.2