

House	Gefion-28	Sheet	2
Drawing	Plan	Scale	1:35
Material	28x135	Date	22.10.2019
Drawer	K.K.	File	Gefion-28.dwg

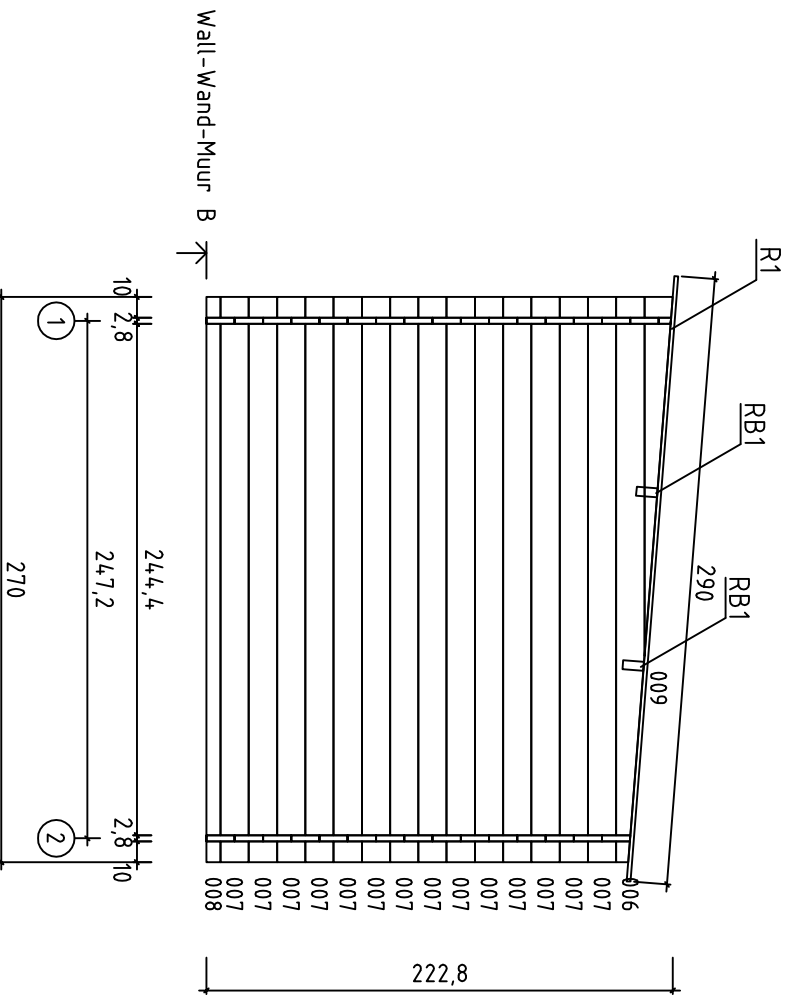

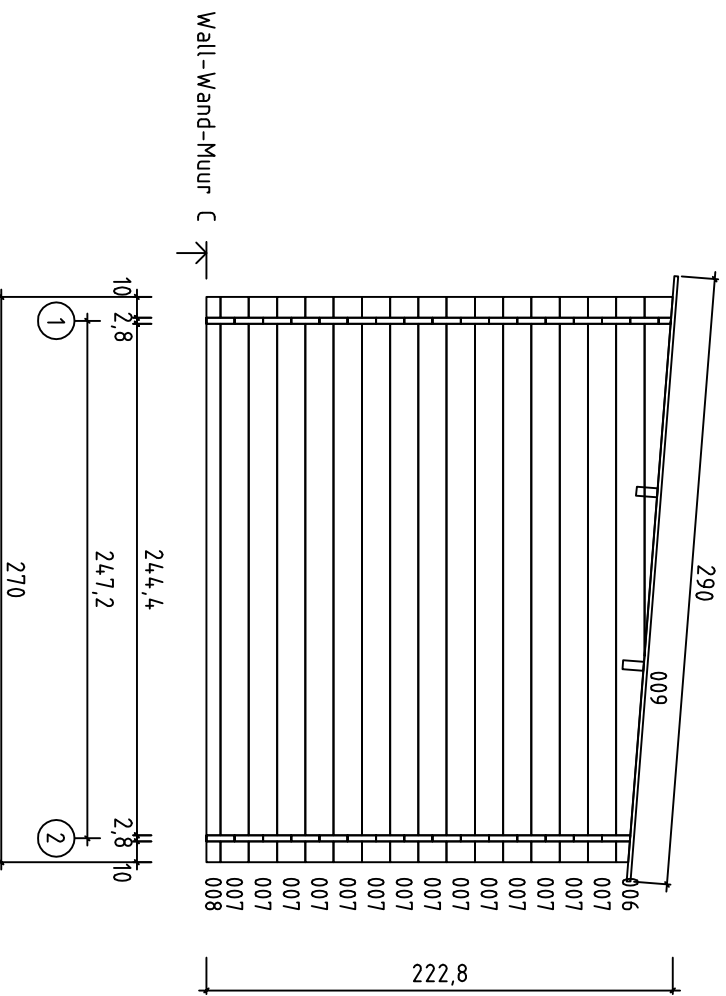





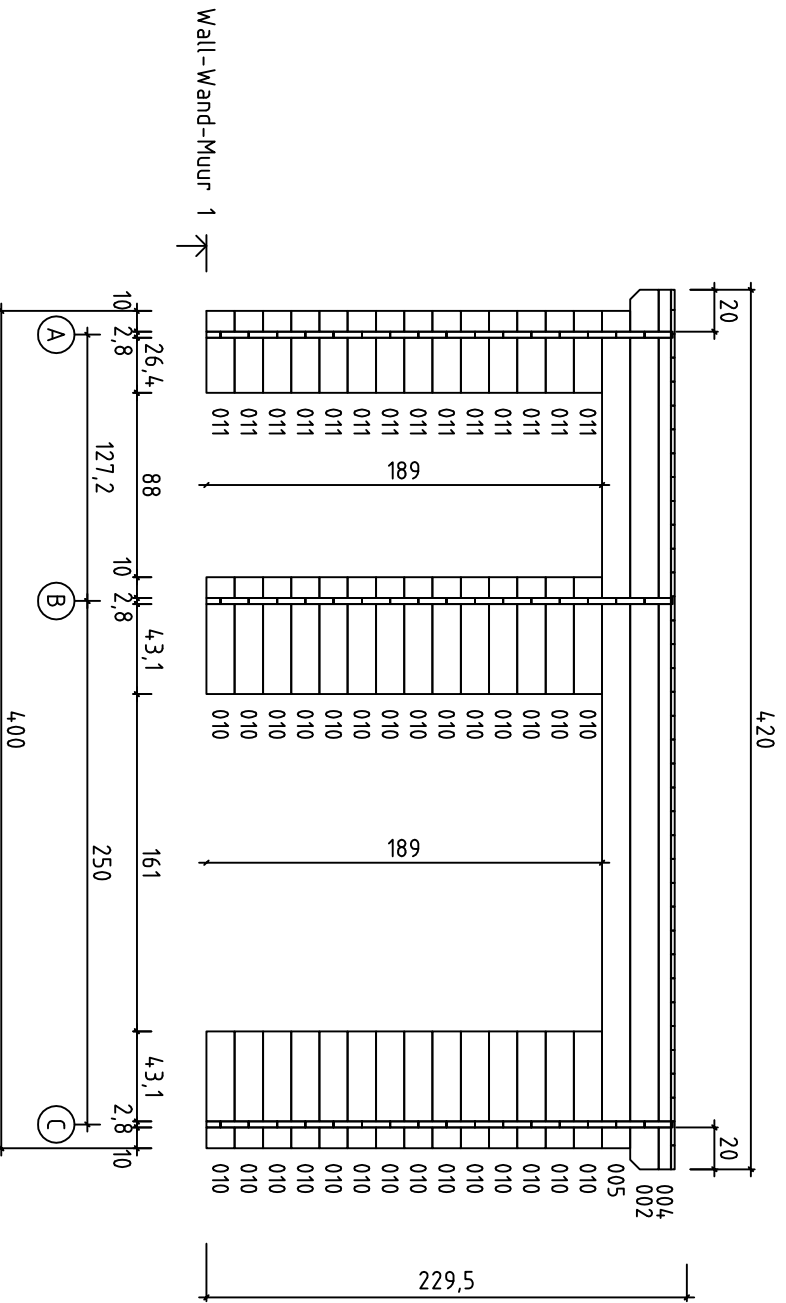



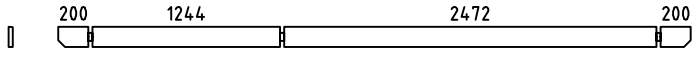
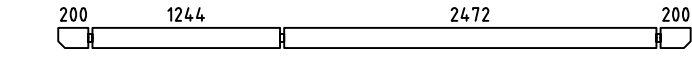
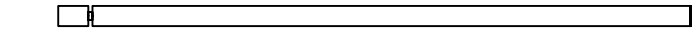
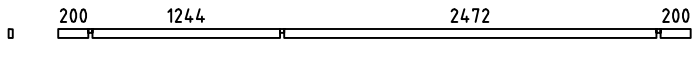
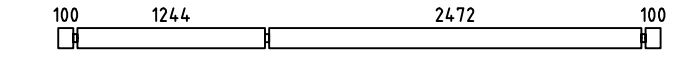
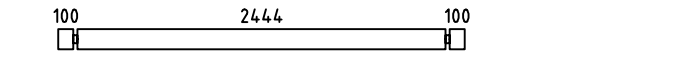
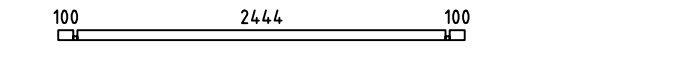

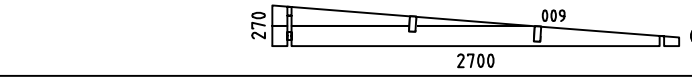

House	Ge'fion-28	Sheet	4
Drawing	WALL - WAND - MUUR B	Scale	1:35
Material	2.8x13.5	Date	22.10.2019
Drawer	K.K.	File	Ge'fion-28.dwg

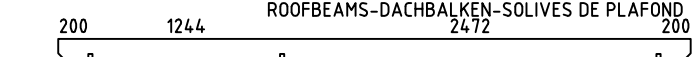

House	Geftion-28	Sheet	5
Drawing	WALL - WAND - MUUR C	Scale	1:35
Material	2.8x13.5	Date	22.10.2019
Drawer	K.K.	File	Geftion-28.dwg



House	Gefion-28	Sheet	6
Drawing	WALL - WAND - MUUR 1	Scale	1:35
Material	2.8x13.5	Date	22.10.2019
Drawer	K.K.	File	Gefion-28.dwg

Pos	Specification-Bestimmung-Omschrijving Gefion-28	Pcs	Profile (mm)	L (mm)
001		1	28x135	4200
002		1	28x135	4200
003	SPARE BEAM-ERZATZBOHLE-VOORRAADPLANK 	1	28x135	4200
004		1	28x60	4200
005		15	28x135	4000
007		42	28x135	2700
008		3	28x68	2700
010		28	28x135	559
011		14	28x135	392
SH	HIT BLOCK-SCHLAGHÖLZER-MADRIERS D'ASSEMBLAGE 	2	28x135	300
WA-1		1	28x270	2700
WB-1		1	28x270	2700
WC-1		1	28x270	2700
RB1	ROOFBEAMS-DACHBALKEN-SOLIVES DE PLAFOND 	2	43x140	4200
R1	ROOFBOARD/DACHBRETTER/KATTOLAUTA  88mm or-oder-ou 114mm	48+1 37+1	18x88 18x114	2900
GB	GABLE BOARD-GIEBELBLENDE-PLANCHE DE RIVE	2	18x120	3000
EB	EAVE BOARD-TRAUFBRETT-LATTES SOUS VOLIGES 	2	18x120	4200
ES	EAVE SLAT-TRAUFLASTE- Baguettes pour fixer les lattes sous voliges 	4	30x40	2100
RFF	ROOF FELT FILLET-GIEBELLEISTE- Baguettes pour fixer les planches de rive 	1 2	18x70	4200 3000
SS1 SS2	STORM SLAT-STURMLEISTE-STORMLIJST 	2 2	35x18	2150 2050
	SCREWS-SCHRAUBEN-SCHROEF (FOR-FÜR-VOOR STORM SLAT-STURMLEISTE-STORMLIJST) 	12	∅6	50
	WASHER-SCHEIBE-SCHIJF (FOR-FÜR-VOOR STORM SLAT-STURMLEISTE-STORMLIJST) 	12	∅6	
Kood	Gefion-28	Materjal	File	Gefion-28.dwg
			Leht	8

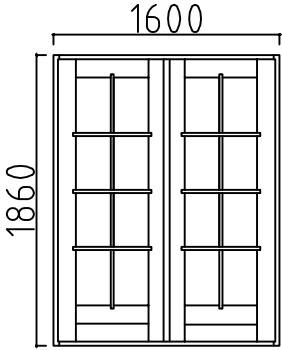
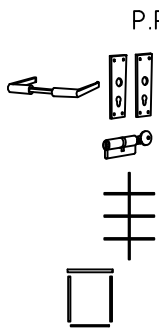
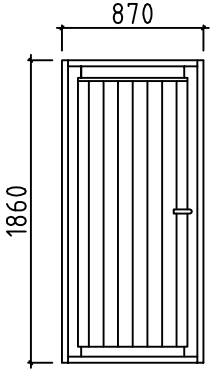
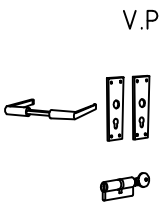
Pos	Specification-Bestimmung-Omschrijving Gefion-28	Pcs	Profile (mm)	L (mm)
	<p data-bbox="336 237 1209 275">DOUBLEDOR-DOPPELTÜR-DUBBELE DEUR (right-rechts-rechts)</p>  <p data-bbox="694 349 798 383">AST_PL</p> 	<p data-bbox="1281 349 1297 376">1</p> <p data-bbox="1281 421 1297 448">1</p> <p data-bbox="1281 488 1297 515">1</p> <p data-bbox="1281 544 1297 571">2</p> <p data-bbox="1281 633 1297 660">1</p>	<p data-bbox="1358 349 1414 376">1600</p>	<p data-bbox="1465 349 1520 376">1860</p>
	<p data-bbox="547 864 1018 902">DOOR-TÜR-DEUR (left-links-links)</p>  <p data-bbox="675 1055 778 1088">AST_PL</p> 	<p data-bbox="1281 1055 1297 1081">1</p> <p data-bbox="1281 1149 1297 1176">1</p> <p data-bbox="1281 1227 1297 1254">1</p>	<p data-bbox="1358 1055 1414 1081">870</p>	<p data-bbox="1465 1055 1520 1081">1860</p>
Kood	Gefion-28	Materjal	File	Gefion-28.dwg
			Leht	9