

MSC/Circ.664

CONTAINERS AND CARGOES

CODE OF SAFE PRACTICE FOR CARGO STOWAGE AND SECURING(CSS CODE)

Amendments to the CSS Code

1 The Maritime Safety Committee, at its sixty-fourth session (5 to 9 December 1994), adopted, in accordance with operative paragraph 3 of Assembly resolution A.714(17), the annexed amendments to the Code of Safe Practice for Cargo Stowage and Securing (CSS Code).

2 Member Governments are invited to bring the said amendments to the attention of shipowners, ship operators, shipmasters and crews and all others concerned.

ANNEX

AMENDMENTS TO THE CODE OF SAFE PRACTICE FOR CARGO STOWAGE AND SECURING

1 Replace the first sentence of paragraph 1.9.1 of chapter 1 by: "Prior to shipment the shipper should provide all necessary information about the cargo to enable the shipowner or ship operator to ensure that."

2 Replace Paragraph 2.9.1 of chapter 2 by: "2.9.1 Where there is reason to suspect that a container or vehicle into which dangerous goods have been packed or loaded is not in compliance with the provisions of regulation VII/5.2 or 5.3 of SOLAS 1974, as amended, or with the provisions of section 12 or 17, as appropriate, of the General Introduction to the IMDG Code, or where a container packing certificate/vehicle packing declaration is not available, the unit should not be accepted for shipment."

3 Replace paragraph 3.2 of annex 6 by: "3.2 The lashings can be of a conventional type using wire, steel band or any equivalent means."

4 Add a new annex 13, as shown in the appendix.

Annex 13

Methods to assess the efficiency of securing arrangements for non-standardized cargo

1. SCOPE OF APPLICATION

The methods described in this annex should be applied to non-standardized cargoes, but not to containers on containerships.

Very heavy units as carried under the provisions of Chapter 1.8 of the Code of Safe Practice for Cargo Stowage and Securing (the Code) and those items for which exhaustive advice on stowage and securing is given in the annexes to the Code should be excluded.

Nothing in this annex should be read to exclude the use of computer software, provided the output achieves design parameters which meet the minimum safety factors applied in this annex. The application of the methods described in this annex are supplementary to the principles of good seamanship and shall not replace experience in stowage and securing practice.

2 PURPOSE OF THE METHODS

The methods should:

- .1 provide guidance for the preparation of the Cargo Securing Manuals and the examples therein;
- .2 assist ship's staff in assessing the securing of cargo units not covered by the Cargo Securing Manual;
- .3 assist qualified shore personnel in assessing the securing of cargo units not covered by the Cargo Securing Manual; and
- .4 serve as a reference for maritime and port related education and training.

3 PRESENTATION OF THE METHODS

The methods are presented in a universally applicable and flexible way. It is recommended that designers of Cargo Securing Manuals convert this presentation into a form suiting the particular ship, its securing equipment and the cargo carried. This form may consist of applicable diagrams, tables or calculated examples.

4. STRENGTH OF SECURING EQUIPMENT

- .1 Manufacturers of securing equipment should at least supply information on the nominal breaking strength of the equipment in kilo-Newton (kN) *1).

*1) 1 kN equals almost 100 kg

- .2 "Maximum Securing Load" (MSL) is a term used to define load capacity for a device used to secure cargo to a ship. Maximum securing load is to securing devices as safe working load is to lifting tackle.

The MSL for different securing devices are given below if not given under 4.3.

The MSL of timber should be taken as 0.3 kN per cm² normal to the grain.

Material	MSL
shackles, rings, deckeyes, turnbuckles of mild	50 % of breaking strength

steel fibre rope web lashing	33 % of breaking strength
wire rope (single use)	70 % of breaking strength
wire rope (re-usable)	80 % of breaking strength
steel band (single use)	30 % of breaking strength
chains	70 % of breaking strength
	50 % of breaking strength

Table 1: Determination of MSL from breaking strength

.3 For particular securing devices (e.g. fibre straps with tensioners or special equipment for securing containers) a permissible working load may be prescribed and marked by authority. This should be taken as the MSL.

.4 When the components of a lashing device are connected in series, for example, a wire to a shackle to a deck eyes, the minimum MSL in the series shall apply to that device.

5. SAFETY FACTOR

Within the assessment of a securing arrangement by a calculated balance of forces and moments the calculation strength of securing devices (CS) should be reduced against MSL using a safety factor of 1.5 as follows:

$$CS = \frac{MSL}{1.5}$$

The reasons for this reduction are the possibility of uneven distribution of forces among the devices, strength reduction due to poor assembly and others. Notwithstanding the introduction of such a safety factor, care should be taken to use securing elements of similar material and length in order to provide a uniform elastic behavior within the arrangement.

6. RULE-OF-THUMB METHOD

.1 The total of MSL values of the securing devices on each side of a unit of cargo (port as well as starboard) should equal the weight of the unit *2)

*2) The weight of the unit should be taken in kN.

.2 This method, which implies a transverse acceleration of 1 g (9.81 m/sec²), applies to nearly any size of ships regardless of the location of stowage, stability and loading conditions, season and area of operation. The method however, neither takes into account the adverse effects of lashing angles and non-homogeneous distribution of forces among the securing devices nor the favourable effect of friction.

.3 Transverse lashing angles to the deck should not be greater than 60° and it is important that adequate friction is provided by the use of suitable material. Additional lashings at angles of greater than 60° may be desirable to prevent tipping but are not to be counted in the number of lashings under the rule-of-thumb.

7. ADVANCED CALCULATION METHOD

7.1 Assumption of external forces

External forces to a cargo unit in longitudinal, transverse and vertical direction should be obtained using the formula:

$$F(x, y, z) = m a(x, y, z) + F_w(x, y) + F_s(x, y)$$

$F(x, y, z)$ = longitudinal, transverse and vertical forces

m = mass of the unit

$a(x, y, z)$ = longitudinal, transverse and vertical acceleration (see table 2)

$F_w(x, y, z)$ = longitudinal and transverse force by wind pressure

$F_s(x, y, z)$ = longitudinal and transverse force by sea sloshing

The basic acceleration data are presented in Table 2.

Transverse acceleration a_y in m/sec^2										Longitudinal acceleration a_x in m/sec^2	
on deck high	7.1	6.9	6.8	6.7	6.7	6.8	6.9	7.1	7.4	3.8	
on deck low	6.5	6.3	6.1	6.1	6.1	6.1	6.3	6.5	6.7	2.9	
tween deck	5.9	5.6	5.5	5.4	5.4	5.5	5.6	5.9	6.2	2.0	
lower hold	5.5	5.3	5.1	5.0	5.0	5.1	5.3	5.5	5.9	1.5	
	0	0.1	0.2	0.3	0.4	0.5	0.6	0.7	0.8	0.9	L
Vertical acceleration a_z in m/sec^2											
	7.6	6.2	5.0	4.3	4.3	5.0	6.2	7.6	9.2		

Table 2: Basic acceleration data

Remarks:

The given transverse acceleration figures include components of gravity, pitch and heave parallel to the deck. The given vertical acceleration figures do not include the static weight component. The basic acceleration data are to be considered as valid under the following operational conditions:

1. Operation in unrestricted area.
2. Operation during the whole year.
3. Duration of the voyage is 25 days.

4. Length of the ship is 100 m.

5. Service speed is 15 knots.

6. $B/GM \geq 13$. (B: breadth of ship, GM: metacentric height)

For operation in a restricted area reduction of these figures may be considered taking also into account the season of the year and the duration of the voyage.

For ships of a length other than 100 m and a service speed other than 15 knots the acceleration figures should be corrected by a factor given in Table 3.

Length Speed	50	60	70	80	90	100	120	140	160	180	200
9 kn	1.20	1.09	1.00	0.92	0.85	0.79	0.70	0.63	0.57	0.53	0.49
12 kn	1.34	1.22	1.12	1.03	0.96	0.90	0.79	0.72	0.65	0.60	0.56
15 kn	1.49	1.36	1.24	1.15	1.07	1.00	0.89	0.80	0.73	0.68	0.63
18 kn	1.64	1.49	1.37	1.27	1.18	1.10	0.98	0.89	0.82	0.76	0.71
21 kn	1.78	1.62	1.49	1.38	1.29	1.21	1.08	0.98	0.90	0.83	0.78
24 kn	1.93	1.76	1.62	1.50	1.40	1.31	1.17	1.07	0.98	0.91	0.85

Table 3: Correction factors for length and speed

In addition for ships with B/GM less than 13, the transverse acceleration figure should be corrected by a factor given in Table 4.

B/GM	7	8	9	10	11	12	13 or above
on deck	1.56	1.40	1.27	1.19	1.11	1.05	1.00
high on deck	1.42	1.30	1.21	1.14	1.09	1.04	1.00
low deck	1.26	1.19	1.14	1.09	1.06	1.03	1.00
tween deck	1.15	1.12	1.09	1.06	1.04	1.02	1.00
lower hold							

Table 4: Correction factors for $B/GM < 13$

The following caution should be observed: In the case of marked roll resonance with amplitudes above $\pm 30^\circ$, the given figures of transverse acceleration may be exceeded. Effective measures should be taken to avoid this condition. In case of heading the seas at high speed with marked slamming shocks, the given figures of longitudinal and vertical acceleration may be exceeded. An appropriate reduction of speed should be considered.

In the case of sunning before large stern or aft quartering seas with a stability, which does not amply exceed the accepted minimum requirements, large roll amplitudes must be expected with transverse accelerations greater than the figures given. An appropriate change of heading should be considered.

Forces by wind and sea to cargo units above the weather deck should be accounted for by a simple approach:

force by wind pressure = 1 kN per m²

force by sea sloshing = 1 kN per m²

Sloshing by sea can induce forces much greater than the figure given above. This figure should be considered as remaining unavoidable after adequate measures to prevent overcoming seas.

Sea sloshing forces need only be applied to a height of deck cargo up to 2 metres above the weather deck or hatch top.

For voyages in restricted area sea sloshing forces may be neglected.

7.2 Balance of forces and moments

The balance calculation should preferably be carried out for

transverse sliding in port and starboard direction

transverse tipping in port and starboard direction

longitudinal sliding under conditions of reduced friction in forward and aft direction.

In case of symmetrical securing arrangements one appropriate calculation is sufficient.

7.2.1 Transverse sliding

The balance calculation should meet the following condition (see also Fig. 1)

$$F_y \leq \mu * m * g + CS_1 * f_1 + \dots + CS_n * f_n$$

where

n is the number of lashings being calculated

F_y is transverse force from load assumption (kN)

μ is friction coefficient

(μ = 0.3 for steel-timber or steel-rubber)

($\mu = 0.1$ for steel-steel dry)

($\mu = 0.0$ for steel- steel wet)

m is mass of cargo unit (t)

g is gravity acceleration of earth = 9.81 (m/s²)

CS is calculated strength of transverse securing devices (kN)

f is function of and vertical securing angle (see Table 5).

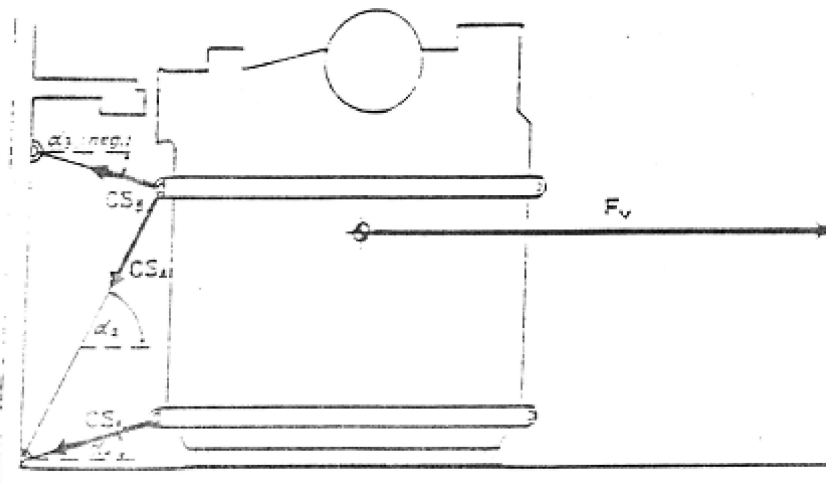

Figure 1: Balance of transverse forces

A vertical securing angle greater than 60° will reduce the effectiveness of this particular securing device in respect to sliding of the unit. Disregarding of such devices from the balance of forces should be considered, unless the necessary load is gained by the imminent tendency to tipping or by a reliable pretensioning of the securing device which includes maintaining the pretension throughout the voyage.

Any horizontal securing angle, i.e. deviation from the transverse direction, should not exceed 3 0°, otherwise an exclusion of this securing device from the transverse sliding balance should be considered.

$\alpha \quad \mu -$ ->	-30°	-20°	-10°	-0°	10°	20°	30°	40°	50°	60°	70°	80°	90°
0.3	0.72	0.84	0.93	1.00	1.04	1.04	1.02	0.96	0.87	0.76	0.62	0.47	0.30
0.1	0.82	0.91	0.97	1.00	1.00	0.97	0.92	0.83	0.72	0.59	0.44	0.27	0.10
0.0	0.87	0.94	0.98	1.00	0.98	0.94	0.87	0.77	0.64	0.50	0.34	0.17	0.00

Table 5: f-values as function of α and μ / Remark: $f = \mu \cdot \sin \alpha + \cos \alpha$

7.2.2 Transverse tipping

This balance calculation should meet the following condition (see also fig. 2):

$$F_y * a \leq b * m * g + CS_1 * c_1 + CS_2 * f_2 + \dots + CS_n * C_n$$

where

F_y , m , g , CS , n are as explained under 7.2.1

a is lever-arm or tipping (m) (see Fig. 2)

b is lever-arm or stableness (m) (see Fig. 2)

c is lever-arm or stableness (m) (see Fig. 2)

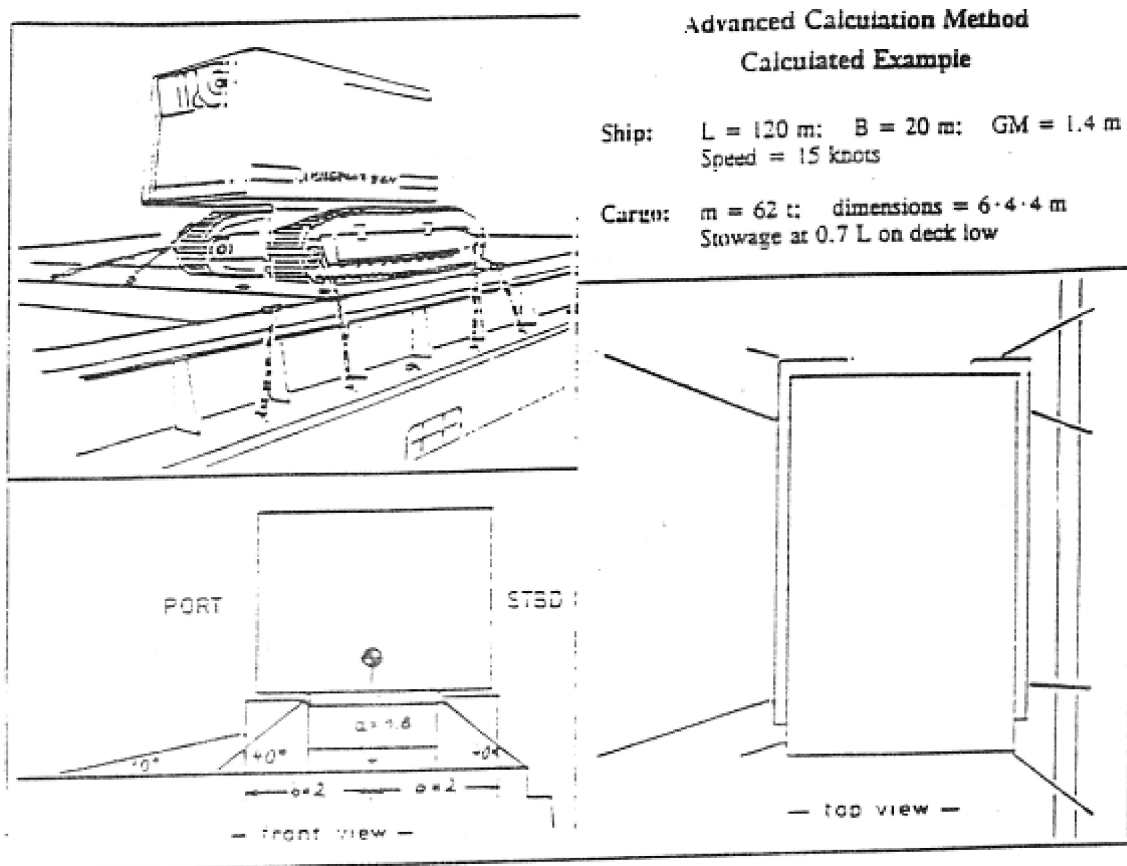

Securing material:

wire rope: br. strength = 125 kN; MSL = 100 kN

shackies, rurnouckies, deck rings: br. strength = 180 kN; MSL = 90 kN

stowed on dunnage-poarus: $\mu = 0.3$; CS = $90/1.5 = 60$ kN

Securing arrangement:

side	n	CS	α	f	c
STBD	4	60 kN	40°	0.96	-
PORT	2	60 kN	40°	0.96	-
PORT	2	60 kN	10°	1.04	-

External forces:

$$F_x = 2.9 \times 0.89 \times 62 + 16 + 8 = 184 \text{ kN}$$

$$F_y = 6.3 \times 0.89 \times 62 + 24 + 12 = 384 \text{ kN}$$

$$F_z = 6.2 \times 0.89 \times 62 = 342 \text{ kN}$$

Balance of forces (STBD-arrangement):

$$384 < 0.3 \times 62 \times 9.81 + 4 \times 60 \times 0.96$$

$$384 < 412 \text{ this is ok!}$$

Balance of forces (PORT-arrangement):

$$384 < 0.3 \times 62 \times 9.81 + 2.60 \times 0.96 + 2.60 \times 1.04$$

$$384 < 422 \text{ this is ok!}$$

Balance of moment: 384

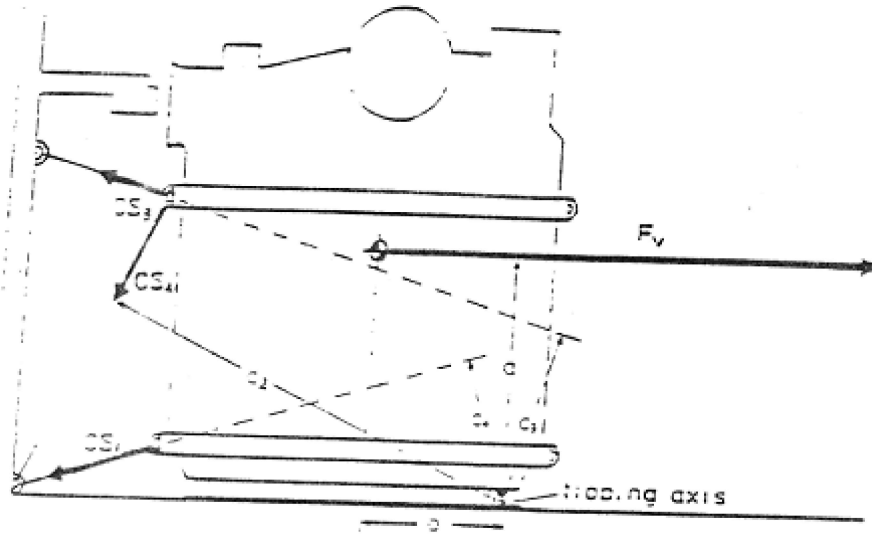

Figure 2: Balance of transverse moments

7.2.3 Longitudinal sliding

Under normal conditions the transverse securing devices provide sufficient longitudinal components to prevent longitudinal sliding. If in doubt, a balance calculation should meet the following condition:

$$F_x \leq \mu * (m * g * F_z) + CS_1 * f_1 + CS_2 * f_2 + \dots + CS_n * f_n$$

where

F_x is longitudinal force from load assumption (kN)

n, μ, m, g are as explained under 7.2.1

F_z is vertical force from load assumption (kN)

CS is calculated strength or longitudinal securing devices (kN)

Remark: Longitudinal components of transverse securing devices should not be assumed greater than $0.5 * CS$.