

# table of contents

## WOW! equipment setup and self-installation

Programming Your WOW! Atlas Universal Remote Control.....	E-1
Programming Channel Control Lock.....	E-3
Programming ID Lock.....	E-3
Programming "Tune-In" Keys For Specific Channels.....	E-4
Using The Master Power Key.....	E-4
Re-Assigning Device Keys.....	E-5
Changing Volume Lock.....	E-5
Atlas Cable Remote Control Codes.....	E-7
Digital Cable Self-Installation.....	E-13
Advanced Digital Equipment Setup.....	E-16
Connecting a Non-Stereo TV.....	E-16
Connecting a Non-Stereo TV and a Non-Stereo VCR.....	E-16
Connecting a Non-Stereo TV and a Stereo VCR.....	E-16
Connecting a Stereo TV.....	E-16
Connecting a Stereo TV and a Non-Stereo VCR.....	E-17
Connecting a Stereo TV and a Stereo VCR.....	E-17
Connecting a Stereo TV and a Stereo VCR with S-Video.....	E-17
Connecting a Stereo TV with S-Video.....	E-17
<b>Digital Cable Receiver Setup Troubleshooting.....</b>	<b>E-18</b>
Programming Your WOW! Digital Cable Remote Control.....	E-19
WOW! Digital Cable Remote Control Codes.....	E-20

## WOW! digital video recorder (dvr) information

Controlling Live TV.....	E-23
Recording TV Programs.....	E-23
Using Picture-In-Picture (PIP).....	E-24
Frequently Asked Questions.....	E-25

## WOW! HD reference guide

Welcome.....	E-26
Before You Begin.....	E-26
Important Rules for Safe Operation.....	E-26
Connecting the Set-Top.....	E-28
Using the Set-Top.....	E-30
Setting Menu Options.....	E-31
<b>Troubleshooting.....</b>	<b>E-31</b>

## digital adapter

Digital Adapter - Self-Install Instructions.....	E-33
Programming Your Remote.....	E-34
Digital Adapter Troubleshooting.....	E-34

# WOW! equipment setup and self-installation

## Programming Your WOW! Atlas Universal Remote Control

The Atlas Universal Remote Control is preprogrammed to operate your cable converter, an RCA TV, an RCA VCR, and a Pioneer audio receiver. To control devices other than the default brands, perform the following steps:

**NOTES:** To control a DVD player, program the **VCR** key. To control a PVR, program the **VCR** key. To control a stereo amplifier or receiver, program the **AUD** key. For TV/VCR Combo control, skip this section and perform the instructions under Programming TV/VCR Combo on page E-2.

- 1 Turn on a device and, if applicable, insert video media, (e.g., cassette or disc).  
*NOTE: Please read steps 2-4 completely before proceeding. Highlight or write down the codes and device you wish to program before moving on to step 2.*
- 2 On the remote control, press a device key once (e.g., AUD, VCR, TV, or CBL). Press and hold SETUP until the selected device key blinks twice, then release SETUP.
- 3 Use the Manufacturer's Codes (starting on page E-7) to locate the type of device and brand name and then enter the first four-digit code for your device. If performed correctly, the selected mode key will blink twice.  
*NOTE: If the selected mode key emits a long blink, the code is invalid. Repeat steps 2 through 3 and try entering the same code again.*  
*For the most current WOW! Atlas remote programming, please visit [www.wowway.com/referenceguide](http://www.wowway.com/referenceguide)*
- 4 Aim the remote control at the device and press POWER once. The device should turn off. If it does not, repeat steps 2-3, trying each code for your brand until you find one that works.  
*NOTE: If the device does not have a POWER key, press the (Play) key.*
- 5 Repeat steps 1 through 4 for each device you want the remote control to control. For future reference, write down each working device code in the boxes below:

After programming, the Atlas Universal Remote Control will be able to control the following types of devices:

DEVICE KEY	CONTROLS THESE TYPES OF DEVICES
	VCR,TV/VCR Combo, PVR (Personal Video Recorder), or extra DVD Player
	DVD Player
	Audio Amplifier, Tuner, or Receiver
	Television
	Cable Box (Converter)

equipment/  
self-installation

## Programming TV/VCR Combo

- 1 Turn on your TV/VCR combo and insert a video cassette.
- 2 On the remote control, press VCR once. Press and hold SETUP until the VCR key blinks twice, then release SETUP.
- 3 Use the Setup Codes For TV/VCR combos visit our URL at [www.wowway.com/referenceguide](http://www.wowway.com/referenceguide) to locate the brand name and then enter the first four-digit code for your TV/VCR combo. If you perform this procedure correctly, the VCR key will blink twice.  
*NOTE: If the VCR key did not blink twice after entering the code's last digit, then repeat steps 2 through 3 and try entering the same code again.*  
*If you've located a TV/VCR setup code that works your TV/VCR combo and a separate TV code is also listed, you'll need to program this code into the remote control to access volume control.*
- 4 Aim the remote control at your TV/VCR combo and press POWER once. The device should turn off. If it does not respond, repeat steps 2-3, trying each code listed for your brand until you find one that works.
- 5 For future reference, write down each working device code in the boxes below:

## Searching for Your Code

If your home entertainment device does not respond to the Atlas Universal Remote Control after trying all of the codes listed for your brand or if your brand is not listed at all, try searching for your code. For example, to search for a code for your TV:

- 1 Turn on your TV.
- 2 On the remote control, press TV once; it will blink once. Then press and hold SETUP until the TV key blinks twice, then release SETUP.
- 3 Enter 9 - 9 - 1. The TV key will blink twice.
- 4 Aim the remote control at the TV and slowly alternate between pressing PWR and TV. Stop when the TV turns off.  
*NOTE: In the search mode, the remote control will send IR codes from its library to the selected device, starting with the most popular code first.*
- 5 Press SETUP once to lock in the code. The TV key will blink twice.
- 6 To search for the codes of your other devices, repeat steps 1 through 5, but substitute the appropriate key (e.g., AUX, DVD, AUD, or CBL) for the device you are searching for.

## Checking the Codes

If you have set up the Atlas Universal Remote Control using the Searching For Your Code procedure, you may need to find out which four-digit code is operating your equipment.

For example, to find out which code is operating your TV:

- 1 On the remote control, press TV once; it will blink once. Then press and hold SETUP until the TV key blinks twice, then release SETUP.
- 2 Enter 9 - 9 - 0. The TV key will blink twice.
- 3 To view the code for the first digit, press 1 once. Wait 3 seconds and count the number of times the TV key blinks (e.g., 3 blinks = 3).  
*NOTE: If a code digit is "0", the selected mode key will not blink.*
- 4 Repeat step 3 three more times for the remaining digits. Use 2 for the second digit, 3 for the third digit, and 4 for the fourth digit.
- 5 To check for other device codes, repeat steps 1 through 4, but substitute the appropriate key (e.g., AUX, DVD, AUD, or CBL) for the device you are checking.

## Programming Channel Control Lock

By default, the remote control's channel-control capabilities are locked to the cable converter. The affected keys\* are 0-9, CH+, CH-, ENTER, and LAST. This will guarantee that you do not inadvertently change a channel on your TV or VCR. However, you can de-activate this feature to allow full access to these keys in the TV and VCR modes.

*\*NOTE: This feature does not affect the AUD mode.*

### To De-Activate Channel Control Lock:

- 1 On the remote control, press CBL once; it will blink once. Then press and hold SETUP until the CBL key blinks twice, then release SETUP.
- 2 Enter 9 -7- 3. The CBL key will blink twice.
- 3 Press CH- once. The CBL key will blink four times.
- 4 Now, the remote control will provide TV and VCR channel-control capabilities while in the TV or VCR mode.

### To Re-Activate Channel Control Lock:

- 1 On the remote control, press CBL once; it will blink once. Then press and hold SETUP until the CBL key blinks twice, then release SETUP.
- 2 Enter 9 -7- 3. The CBL key will blink twice.
- 3 Press CH+ once. The CBL key will blink twice.
- 4 Now, regardless of what mode you select (except AUD), only the channel control capability of your cable converter will be accessible.

## Programming ID Lock

The Atlas Universal Remote Control is locked at the factory to operate a Scientific Atlanta cable converter. However, if you have another brand or model of cable converter or satellite service that you would like to control, then you'll need to perform the following steps to unlock the ID Lock, enter in a new manufacturer's code, and lock the ID Lock again.

- 1 Turn on the cable converter.
- 2 On the remote control, press CBL once; it will blink once. Then press and hold SETUP until the CBL key blinks twice, then release SETUP.
- 3 Enter 9 - 8 - 2. The CBL key will blink four times, indicating ID Lock is unlocked.
- 4 Upon completion, perform the remaining steps (5 and 6 on this page) to again lock the ID Lock.
- 5 On the remote control, press CBL once; it will blink once. Then press and hold SETUP until the CBL key blinks twice, then release SETUP.
- 6 Enter 9 - 8 - 2. The CBL key will blink twice, indicating ID Lock is again locked.

## Programming “Tune-In” Keys for Specific Channels

The Atlas Universal Remote Control includes three “Tune-In” keys (located directly below the MUTE and LAST keys). Each can be programmed to remember three of your favorite cable channel settings for a total of nine channels. If you want to change the cable channels in a previously-programmed “Tune-In” key, you’ll need to clear the key first.

### To Program A “Tune-In” Key:

- 1 On the remote control, press CBL once; it will blink once. Then press and hold SETUP until the CBL key blinks twice, then release SETUP.
- 2 Enter 9 - 9 - 5. The CBL key will blink twice. Then select a “Tune-In” key and press it once.
- 3 Press CBL once followed by the channel number to be programmed (e.g., 3 - 9).

*NOTE: If you are programming a channel for a Digital Cable Converter, you need to enter all channels in a 3-digit channel format. For example, if the desired channel is 39, then enter it as 0 - 3 - 9.*

- 4 Press and hold SETUP until the CBL key blinks twice, then release SETUP.
- 5 To add another channel, repeat steps 1 through 4, substituting the new channel to be added in step 3.

*NOTE: Programming more than three channels on the same “Tune-In” key will overwrite previous settings.*

### To Clear A “Tune-In” Key:

- 1 On the remote control, press CBL once; it will blink once. Then press and hold SETUP until the CBL key blinks twice, then release SETUP.
- 2 Enter 9 - 9 - 5. The CBL key will blink twice. Then select a “Tune-In” key you want to clear and press it once.
- 3 Press and hold SETUP until the CBL key blinks twice, then release SETUP.
- 4 This “Tune-In” key is now clear and ready for reprogramming. If desired, repeat steps 1 through 3 in this section to clear another “Tune-In” key.

## Using the Master Power Key

The Atlas Universal Remote Control has a unique feature that allows you to sequentially turn on or off up to five of your home entertainment devices with a single key press.

### To Program The Master Power Key:

- 1 On the remote control, press and hold SETUP until the last-selected device key blinks twice, then release SETUP.
- 2 Enter 9 - 9 - 5. The last-selected device key will blink twice. Then press PWR once.
- 3 For the first device you want in the power on sequence, press a device key (e.g., CBL) once. Then press PWR once.
- 4 Repeat step 3 up to four more times to add the second, third, fourth, and fifth device, as desired.
- 5 To save the settings and exit the program, press and hold SETUP until the last-selected device key blinks twice, then release SETUP.

### To Operate The Master Power Key:

*NOTE: If MASTER POWER is not programmed, pressing it will only command the last-selected device to power on or off.*

- 1 After programming, point the remote control at the devices and press "CBL" once.
- 2 Press and hold PWR for at least 2 seconds. You will see the devices power on or off according to the programmed sequence.

### To Clear The Master Power Key:

- 1 Perform steps 1 and 2 in the first section above, "To Program The Master Power Key."
- 2 To clear the settings and exit the program, press and hold SETUP until the last-selected device key blinks twice, then release SETUP.

## Re-Assigning Device Keys

The Atlas Universal Remote Control can be set up to control a second device. For example, to have the unit control a TV, a Cable Converter, and two DVD Players, you will need to re-assign the unused AUX key to operate the second DVD Player as follows:

*NOTE: AUX is preset at the factory to control an RCA VCR. Performing the below steps will overwrite those settings.*

- 1 On the remote control, press AUX once; it will blink once. Then press and hold SETUP until the AUX key blinks twice, then release SETUP.
- 2 Enter 9 - 9 - 2. The AUX key will blink twice.
- 3 Press DVD once, then press AUX once. The AUX key will blink twice.
- 4 The AUX key is now ready to be programmed for your second DVD player.

To re-assign other device keys, repeat steps 1 through 4 and substitute the key sequence using the following chart:

*NOTE: Only one device can be assigned to an unused device key at a time.*

To Re-Assign	Perform Key Sequence
AUX as 2nd AUD key:	AUX - SETUP - 9 - 9 - 2 - AUD - AUX
AUX as 2nd TV key:	AUX - SETUP - 9 - 9 - 2 - TV - AUX
AUX as 2nd CBL key:	AUX - SETUP - 9 - 9 - 2 - CBL - AUX
AUX back to AUX:	AUX - SETUP - 9 - 9 - 2 - AUX - AUX

To re-assign another unused device key, substitute it for the AUX key above and then perform the sequence. For example, to re-assign an unused AUD key as a second DVD key, perform AUD - SETUP - 9 - 9 - 2 - DVD - AUD. When a re-assignment is done, the selected device key (e.g., AUD) will blink twice to confirm your choice.

## Changing Volume Lock

On this remote control, Global Volume Lock is set to TV, so you can control TV volume while in the AUX, DVD, TV or CBL mode. If desired, you can still perform Individual Volume Unlock on a selected device to set its volume control for independent operation.

*NOTE: The audio mode's volume controls are active regardless of Volume Lock settings. However, if you lock the volume controls to the AUD mode, you will have control of the audio device's volume in all other modes (i.e., AUX, DVD, TV, and CBL).*

### **To Unlock Volume Control For A Single Device (Individual Volume Unlock):**

- 1 Assuming Global Volume Lock is active, select a mode on the remote control that you want to unlock (e.g., CBL) and press it once. Next, press and hold SETUP until the device key blinks twice, then release SETUP.
- 2 Enter 9 - 9 - 3. The last-selected device key will blink twice.
- 3 Press VOL- once. The last-selected device key will blink four times.
- 4 Repeat steps 1 through 3 (of this section) for each device you want volume to be unlocked.
- 5 Now, after you select a device that has volume unlocked (e.g., CBL), pressing VOL+, VOL-, or MUTE will control the device's volume only in its own mode.

### **To Unlock All Volume Control (Global Volume Unlock):**

*NOTE: Performing these instructions will set independent volume control for all programmed devices.*

- 1 On the remote control, press and hold SETUP until the last-selected device key blinks twice, then release SETUP.
- 2 Enter 9 - 9 - 3. The last-selected device key will blink twice.
- 3 Press VOL+ once. The last-selected device key will blink four times.

### **To Lock Volume Control To One Mode (Global Volume Lock):**

*NOTE: The audio mode's volume controls are active regardless of Volume Lock settings. However, if you lock the volume controls to the AUD mode, you will have control of the audio device's volume in all other modes (i.e., AUX, DVD, TV, and CBL).*

- 1 On the remote control, press and hold SETUP until the last-selected device key blinks twice, then release SETUP.
- 2 Enter 9 - 9 - 3. The last-selected device key will blink twice.
- 3 Select a mode (e.g., TV) where you want to globally lock the volume controls. The selected device key will blink twice.
- 4 Now, when you press VOL+, VOL-, or MUTE, the volume of the selected device (e.g., TV) can be controlled regardless of mode.

# WOW! Atlas Cable Remote Control Codes

Use these codes if you have the WOW! Atlas Remote (page C-3)

For the most current WOW! Atlas remote programming, please visit [www.wowway.com/referenceguide](http://www.wowway.com/referenceguide)

## SETUP CODES FOR AUDIO

### AMPLIFIERS:

Adcom	0577, 1100
Bose	0674
Durabrand	1561
Elan	0647
GE	0078
Harman/Kardon	0892
JVC	0331
Left Coast	0892
Lenox	1561
Luxman	0165
Marantz	0892, 0321
McIntosh	0251
Nakamichi	0321
NEC	0264
Optimus	0395, 0823
Parasound	0246
Philips	0892
Pioneer	0823
Polk Audio	0892
RCA	0823
Realistic	0395
Sansui	0321
Shure	0264
Sony	0689, 0815, 1126
Soundesign	0078, 0211
Victor	0331
Wards	0078, 0211
Yamaha	0354, 0133

## SETUP CODES FOR AUDIO

### RECEIVERS:

ADC	0531
Aiwa	1405, 0189, 0121, 0405, 1243, 388, 1641
Akai	1512
Alco	1390
Amphion Media Works	1563, 1615
AMW	1563, 1615
Anam	1609, 1074
Apex Digital	1257, 1430, 1774
Arcam	1120
Audiotronic	1189
Audiovox	1390, 1627
B & K	0701, 0820, 0840
BK	0702
Bose	1229, 1629, 1841, 1933
Cambridge Soundworks	1370
Capetronic	0531
Carver	1189, 0189
Classic	1352
Coby	1389
Curtis Mathes	0080
Daewoo	1250
Delphi	1414
Denon	1360, 0004, 1142
Fisher	1801
Gateway	1517

Go Video	1532
Harman/Kardon	0110, 0189, 0891, 1304, 1306
Hitachi	1801
Integra	0135, 1298, 1320
JBL	0110, 1306
JVC	1374, 1495, 1811, 1871
Kenwood	1313, 1570, 1569, 0186
KLH	1390, 1412, 1428
Koss	1366, 1497
Lasonic	1798
LG	1293
Linn	0189
Liquid Video	1497
Magnavox	1189, 1269, 0189, 0391, 0531, 1514
Marantz	1189, 1269, 0189, 1289
Mitsubishi	1393
Norcent	1389
Nova	1389
Onkyo	0135, 0842, 1298, 1320, 1531
Optimus	1023, 0080, 0186, 0531, 0670, 1074
Oritron	1366, 1497
Panasonic	1308, 1518, 0309, 0367, 1288, 1316, 1548, 1633, 1763, 1764
Philips	1189, 1269, 0189, 0391, 1120, 1266
Pioneer	1023, 0014, 0080, 0150, 0244, 0531, 0630, 1384
Polaroid	1508
Polk Audio	0189, 1289, 1414
Proscan	1254
RCA	1023, 1609, 1254, 0080, 0531, 1074, 1390, 1511
Rio	1869
Samsung	1295, 1500
Sansui	0189
Sanyo	1251, 1469, 1801
Sharp	0186, 1286
Sharper Image	1556
Sherwood	1077, 1517, 1653
Sirius	1627, 1811, 1987
Sonic Blue	1532, 1869
Sony	1058, 1441, 1258, 1759, 1622, 0474, 1349, 1406, 1442, 1558, 1658, 1758, 1858
Soundesign	0670
Stereophonics	1023
Sunfire	1313
Teac	1074, 1390, 1528
Technics	1308, 1518, 0309
Thorens	1189
Toshiba	1788
Venturer	1390
Wards	0189, 0014, 0080

XM	1406, 1414
Yamaha	0176, 0186, 1176, 1276, 1331, 1375
Zenith	0857, 1293

## SETUP CODES FOR DVD PLAYERS:

Accurian	1072, 1416
Adcom	1094
Advent	1016
Aiwa	0641
Akai	0695, 0770, 0899, 1089
Alco	0790
Allegro	0869
Amphion Media Works	0872, 1245
AMW	0872, 1245
Apex Digital	0672, 0717, 0755, 0794, 0796, 0797, 0830, 1004, 1020, 1056, 1061, 1100
Arrgo	1023
Aspire Digital	1168, 1407
Audiologic	0736
Audiovox	0790, 1041, 1071, 1072, 1121, 1122
Axion	1071, 1072
B & K	0655, 0662
BBK	1224
Bel Canto Design	1571
Blaupunkt	0717
Blue Parade	0571
Broksonic	0695, 0868, 1419
Buffalo	1882
Cary Audio Design	1477
CAVS	1057
Centrios	1577
Cinea	0831
Cinego	1399
CineVision	0876, 0833, 0869
Citizen	1277
Coby	0778, 0852, 1086, 1107, 1165, 1177, 1351
Craig	0831
Curtis Mathes	1087
CyberHome	0816, 0874, 1023, 1024, 1117, 1129, 1502, 1537
D-Link	1881
Daewoo	0784, 0705, 0833, 0869, 1169, 1172, 1234, 1242, 1441, 1443
Denon	0490, 0634
Desay	1407, 1455
Diamond Vision	1316, 1609, 1610
Disney	0675, 1270
Dual	1068, 1085
Durabrand	1127
DVD2000	0521
Emerson	0591, 0675, 0821, 1268
Enterprise	0591
ESA	0821, 1268, 1443



Fisher	0670, 1919
Funai	0675, 1268, 1334
Gateway	1073, 1077, 1158
GE	0522, 0815, 0717
Go Video	0744, 0715, 0741, 0783, 0833, 0869, 1044, 1075, 1099, 1144, 1158, 1304, 1443, 1730
Go Vision	1071, 1072
GoldStar	0741
GPX	0699, 0769
Greenhill	0717
Harman/Kardon	0582, 0702
Hitachi	0573, 0664, 1247, 1919
Hiteker	0672
iLo	1348, 1472
Initial	0717, 1472
Innovative Technology	1542
Insignia	1268
Integra	0627
Jaton	1078
JBL	0702
Jensen	1016
JSI	1423
JVC	0558, 0623, 0867, 1164, 1275, 1602, 1863
jWin	1049, 1051
Kawasaki	0790
Kenwood	0490, 0534, 0682, 0737
KLH	0717, 0790, 1020, 1149, 1261
Konka	0711, 0719, 0720, 0721
Koss	0651, 0896, 1423
Kreisen	1421
Landel	0826
Lasonic	0798, 1173
Lenoxx	1127
LG	0591, 0741, 0801, 0869, 1526
LiteOn	1058, 1158, 1416, 1440
Loewe	0511
Magnavox	0503, 0539, 0646, 0675, 0821, 1268, 1506
Malata	0782, 1159
Marantz	0539
McIntosh	1273
Memorex	0695, 0831, 1270
Microsoft	0522, 1708
Mintek	0839, 0717, 1472
Mitsubishi	1521, 0521
Momitsu	1082
NAD	0741
Nakamichi	1222
NEC	0785
Nesa	0717, 1603
NeuNeo	1454
Next Base	0826
NexTech	1402
Norcent	1003, 0872, 1107, 1265, 1457
Onkyo	0503, 0627, 0792
Oppo	1224, 1525

OptoMedia Electronics	0896
Oritron	0651
Panasonic	0490, 0632, 0703, 1362, 1462, 1490, 1762
Philips	0503, 0539, 0646, 0675, 0854, 1260, 1267, 1354
Pioneer	0525, 0571, 0631, 0632
Polaroid	1020, 1061, 1086, 1245, 1316, 1478, 1480, 1482
Polk Audio	0539
Portland	0770
Presidian	0675, 1072
Prima	1016
Primare	1467
Princeton	0674
Proscan	0522
ProVision	0778
Qwestar	0651
RCA	0522, 0571, 0717, 0790, 0822, 1022, 1132, 1193
Rio	0869
RJTech	1360
Rotel	0623, 1178
Rowa	0823
Sampo	0698, 0752, 1501
Samsung	0490, 0573, 0820, 0899, 1044, 1075
Sansui	0695
Sanyo	0670, 0695, 0873, 1919
Sensory Science	1158
Sharp	0630, 0675, 0752, 1256
Sharper Image	1117
Sherwood	0633, 0770, 1043, 1077, 1889
Shinsonic	0533, 0839
Sigma Designs	0674
Sonic Blue	0869, 1099
Sony	0533, 1533, 0864, 1033, 1431, 1432, 1433, 1548, 1892
Sound Mobile	1298
Sova	1122
Sungale	1074, 1532
Superscan	0821
SVA	0860, 1105
Sylvania	0675, 0821, 1268
Symphonic	0675, 0821
TAG McLaren	0894
Teac	0790, 0809
Technics	0490, 0703
Technosonic	0730
Techwood	0692
Terapin	1031
Theta Digital	0571
Toshiba	0503, 0695, 1045, 1154, 1854
Tredex	0799, 0800, 0803, 0804
Urban Concepts	0503
US Logic	0839
Valor	1298
Venturer	0790
Vialta	1509

Vizio	1064, 1226
Vocopro	1027, 1360
Xbox	0522, 1708
Xwave	1001
Yamaha	0490, 0539, 0545
Zenith	0503, 0591, 0741, 0869
Zoece	1265

**SETUP CODES FOR TVS:**

A-Mark	0003
Abex	0032
Accurian	1803
Action	0873I
Admira	0093, 0463
Advent	0761, 0783, 0815, 0817, 0842, 1933
Adventura	0046
Aiko	0092
Aiwa	0701
Akai	0812, 0702, 0030, 0098, 0672, 1207, 1903, 1935
Alaron	0179, 0183, 0216
Albatron	0700, 0843
Ambassador	0177
America Action	0180
Ampro	0751
Anam	0180, 0004, 0009, 0068
Anam National	0055, 0161
AOC	0030, 0003, 0019, 0052, 0137, 0185, 1365
Apex Digital	0748, 0879, 0765, 0767, 0890, 1217, 1943
Archer	0003
Astar	1548
Audiovox	0451, 0180, 0092, 0003, 0623, 0710, 0802, 0846, 0875, 1284, 1937, 1951, 1952
Aventura	0171
Axion	1937
Belcor	0019
Bell & Howell	0154, 0016
BenQ	1032, 1315
Bradford	0180
Brockwood	0019
Broksonic	0236, 0463, 0003, 1935, 1938
Byd:sign	1309, 1311
Cadia	1283
Candle	0030, 0046, 0056, 0186
Carnivale	0030
Carver	0054, 0170
CCE	0217, 0329
Celebrity	0000

Celera	0765	Gibraltar	0017, 0030, 0019	1963, 1944, 1525, 1254,	
Champion	1362	Go Video	0886	1198, 0802, 0386, 0230,	
Changhong	0765	GoldStar	0178, 0030, 0001, 0002,	0187, 0186, 0179, 0096,	
Cinego	1986		0019, 0032, 0106, 0409	0036, 0028, 0024, 0020	
Citizen	0060, 0030, 0092, 0039,	Goodmans	0360	Majestic	0015, 0016
	0046, 0056, 0186, 0280	Gradiente	0392	Marantz	0054, 0030, 0444, 0704,
Clairtone	0185	Grunpy	0180, 0179		0854, 0855, 1154, 1398
Clarion	0180	Haier	1034, 0768	Matsushita	0250, 0650
Commercial Solutions	1447, 0047	Hallmark	0178	Maxent	0762, 1211, 1755
Concerto	0056	Hannspree	1348, 1351, 1352	Megapower	0700
Contec	0180, 0157, 0158, 0185	Hantarex	1338	Megatron	0178, 0145, 0003
Craig	0180, 0161	Harley Davidson	0043, 0179	MEI	0185
Crosley	0054	Harman/Kardon	0054, 0078	Memorex	0154, 0463, 0150, 0178,
Crown	0180, 0039	Harvard	0180, 0068		0016, 0106, 0179
Curtis Mathes	0047, 0054, 0154, 0451,	Havermy	0093	MGA	0150, 0178, 0030, 0019,
	0093, 0060, 0702, 0030,	Helios	0865		0155
	0145, 0166, 1347, 1147,	Hello Kitty	0451	Midland	0047, 0017, 0051, 0032,
	0747, 0466, 0056, 0039,	Hewlett Packard	1088, 1089, 1101, 1494,		0039, 0135, 0747
	0016		1502	Mintek	1603, 1990
CXC	0180	Hisense	0748	Minutz	0021
CyberHome	0794	Hitachi	1145, 0145, 0016, 0032,	Mitsubishi	0093, 1250, 0150, 0178,
Cytron	1326		0038, 0056, 0095, 0097,		0014, 0019, 0098, 0155,
Daewoo	0451, 0092, 1661, 0019,		0151, 0173, 0227, 0279,		0331, 0358, 0836, 0868,
	0039, 0066, 0067, 0091,		0409, 0413, 0797, 1960		1550
	0623, 0661, 0672	HP	1088, 1089, 1101, 1494,	Monivision	0700, 0843
Daytron	0019		1502	Motorola	0093, 0055, 0835
Dell	1080, 1178, 1264, 1403	Hyundai	0849, 1219, 1294	Moxell	0835
Denon	0145, 0511	iLo	1286, 1603, 1990	MTC	0060, 0030, 0019, 0049,
Denstar	0628	Infinity	0054		0056, 0091, 0185, 0216
Diamond Vision	1996, 1997	Initial	1603, 1990	Multitech	0180, 0049, 0217
Dumont	0017, 0019	Insighnia	0171, 1204, 1326, 1517,	NAD	0156, 0178, 0866
Durabrand	0463, 0180, 0178, 0171,		1963, 2002	NEC	0030, 0019, 0036, 0056,
	1034, 0003	Inteq	0017		0170, 0434, 0497, 0882,
Dwin	0720, 0774	Janeil	0046		1398, 1704
Dynatech	0049	JBL	0054	Neovia	1338
Electroband	0000, 0185	JCB	0000	NetTV	0762, 1755
Electrograph	1623, 1755	Jensen	0761, 0050, 0815, 0817,	Nikko	0178, 0030, 0092, 0317
Electrohome	0381, 0389, 0409		1299, 1933	Noblex	0430
Emerson	0154, 0236, 0463, 0180,	JVC	0053, 0036, 0069, 0160,	Norcent	0748, 0824, 1089, 1365,
	0178, 0171, 1963, 1944,		0169, 0182, 0731, 1253		1589, 1590, 1591
	0623, 0282, 0280, 0270,	Kamp	0216	Norwood Micro	1286, 1296, 1303
	0185, 0183, 0182, 0181,	Kawasho	0158, 0216, 0308	Noshi	0018
	0179, 0177, 0158, 0039,	Kaypani	0052	NTC	0092
	0038, 0019	KEC	0180	Olevia	1144, 1240, 1331, 1610
Emprex	1422, 1546	Kenwood	0030, 0019	Olympus	1342
Envision	0030, 0813, 1365	KLH	0765, 0767, 1962	Orwa	0180
Epson	0833, 0840, 1290	Kloss	0024, 0046, 0078	Optimus	0154, 0250, 0166, 0650
ESA	0812, 0171, 1944, 1963	KMC	0106	Optoma	0887
Fisher	0154, 0159	Konka	0628, 0632, 0638, 0703,	Optonica	0093, 0165
FlexiVision	0710		0707	Orion	0236, 0463, 1463, 0179
Fujitsu	0179, 0186, 0683, 0809,	Kost	1262, 1483	Panasonic	0250, 0051, 0055, 0162,
	0853	KTV	0180, 0030, 0039, 0183,		0226, 0338, 0375, 0650,
Funai	0180, 0171, 0179, 1271,		0185, 0217, 0280		1291, 1410, 1941, 1946,
	1963	LG	1265, 0178, 0442, 0700,		1947
Futuretech	0180		0829, 0856, 1178, 1325,	Penney	0047, 0156, 0051, 0060,
Gateway	1001, 1002, 1003, 1004,		1423, 1758, 1993		0178, 0030, 1347, 0747,
	1755, 1756	Loewe	0136		0309, 0149, 0138, 0135,
GE	1447, 0047, 0051, 0451,	Logik	0016		0110, 0039, 0032, 0027,
	0178, 1347, 0747, 0282,	Luxman	0056		0021, 0019, 0018, 0003,
	0279, 0251, 0174, 0138,	LXI	0047, 0054, 0154, 0156,		0002
	0135, 0055, 0029, 0027,		0178, 0148, 0747	Petters	1523
	0021	Magnavox	1454, 0054, 0030, 0706,	Philco	0054, 0030, 0019, 0020,

	0028, 0096, 0302
Philips	1454, 0054, 0690, 1154, 1483
Pilot	0030, 0019, 0039
Pioneer	0166, 0038, 0172, 0679, 0866, 1260, 1398
Polaroid	0765, 0865, 1262, 1276, 1314, 1316, 1326, 1327, 1328, 1341, 1498, 1523, 1991, 1992
Portland	0092, 0019, 0039
Prima	0761, 0783, 0815, 0817, 1933
Princeton	0700, 0717
Prism	0051
Proscan	1447, 0047, 0747, 1347
Proton	0178, 0003, 0031, 0052, 0466
Protron	1320, 1323
Proview	0835, 1401, 1498
Pulsar	0017, 0019
Quasar	0250, 0051, 0055, 0165, 0219, 0650
RadioShack	0047, 0154, 0180, 0178, 0030, 0019, 0032, 0039, 0056, 0165, 0409, 0747
RCA	1447, 0047, 2002, 1958, 1953, 1948, 1547, 1347, 1247, 1147, 1047, 0747, 0679, 0278, 0174, 0135, 0090, 0038, 0029, 0019, 0018
Realistic	0154, 0180, 0178, 0030, 0019, 0032, 0039, 0056, 0165
Rhapsody	0183, 0185, 0216
Runco	0017, 0030, 0251, 0497, 0603, 1398
Sampo	0030, 0032, 0039, 0052, 0100, 0110, 0762, 1755
Samsung	0060, 0812, 0702, 0178, 0030, 1903, 1575, 1395, 1312, 1060, 0814, 0766, 0427, 0408, 0329, 0056, 0032, 0019
Samsux	0039
Sansui	0463, 1409, 1935
Sanyo	0154, 0088, 0107, 0146, 0159, 0232, 0484, 0799, 0893, 1142
Sceptre	0878, 1217, 1360, 1599
Scrimitsu	0019
Scotch	0178
Scott	0236, 0180, 0178, 0019, 0179, 0309
Sears	0047, 0054, 0154, 0156, 0178, 0171, 0015, 0056, 0146, 0148, 0149, 0159, 0168, 0179, 0281, 0747
Sharp	0093, 0039, 0153, 0157, 0165, 0220, 0281, 0386, 0398, 0491, 0688, 0689,

	0818, 0851, 1602
Sheng Chia	0093
Sherwood	1399
Shogun	0019
Signature	0016
Signet	1262
SIM2 Multimedia	1297
Simpson	0186, 0187
Sony	1100, 0000, 0011, 0080, 0111, 0273, 0353, 0810, 0834, 1317
Soundesign	0180, 0178, 0179, 0186
Sova	1320, 1952
Soyo	1520
Spectricon	0003, 0137
Squareview	0171
SSS	0180, 0019
Starlite	0180
Studio Experience	0843
Superscan	0093, 0864
Supre-Macy	0046
Supreme	0000
SVA	0748, 0587, 0768, 0865, 0870, 0871, 0872
Sylvania	0054, 0030, 0171, 0020, 0028, 0065, 0096, 0381, 1271, 1944, 1963
Symphonic	0180, 0171, 1944
Syntax	1144, 1240, 1331
Tandy	0093
Tatung	0003, 0049, 0055, 0396, 1101, 1285, 1286, 1287, 1288, 1361, 1756
Technics	0250, 0051
Technol Ace	0179
Technovox	0007
Techview	0847
Techwood	0051, 0003, 0056
Teknika	0054, 0180, 0150, 0060, 0092, 0016, 0019, 0039, 0056, 0175, 0179, 0186, 0312, 0322
Telefunken	0702, 0056, 0074
Tera	0031
Thomson	0209, 0210
TMK	0178, 0056, 0177
TNCi	0017
Toshiba	0154, 1256, 0156, 1265, 0060, 1945, 1935, 1704, 1656, 1635, 1356, 1343, 1325, 1306, 1156, 0845, 0832, 0650, 0149, 0036
Tosonic	0185
Totevision	0039
Trical	0157
TVS	0463
Ultra	0391, 1323
Universal	0027
Universum	1337
US Logic	1286, 1303
Vector Research	0030
Victor	0053

Video Concepts	0098
Vidikron	0054, 0242, 1398
Vidtech	0178, 0019, 0036
Viewsonic	0797, 0857, 0864, 0885, 1330, 1342, 1578, 1627, 1755
Viking	0046, 0312
Viore	1207
Visart	1336
Vizio	0864, 0885, 1499, 1756, 1758
Wards	0054, 0178, 0030, 1156, 0866, 0202, 0179, 0174, 0165, 0111, 0096, 0080, 0056, 0029, 0028, 0027, 0021, 0020, 0019, 0016
Waycon	0156
Westinghouse	0885, 0889, 0890, 1282, 1577
White Westinghouse	0463, 0623
Wyse	1365
Yamaha	0030, 0019, 0769, 0797, 0833, 0839
Zenith	0017, 0463, 1265, 0178, 0092, 0016
Zonda	0003

#### SETUP CODES FOR TVS (DLP)

Hewlett Packard	1494
HP	1494
LG	1265
Magnavox	1525
Mitsubishi	1250
Optoma	0887
Panasonic	1291
RCA	1447
Samsung	0812, 1060, 1312
SVA	0872
Toshiba	1265, 1306
Vizio	1499

#### SETUP CODES FOR TVS (HDTV)

Advent	0842
Hitachi	1960
Marantz	0854
Mitsubishi	0150
Panasonic	0250, 0650, 1291
Pioneer	0679
Princeton	0717
RCA	1447
Samsung	0812, 0702
Sharp	0688, 0689
Toshiba	1256

#### SETUP CODES FOR TVS (LCD)

Accurian	1803
Action	0873
Akai	1935
AOC	1365
Apex Digital	0890, 1217
Astar	1548

Audiovox	0180, 0710, 0802, 0846, 0875, 1284, 1937, 1951, 1952
BenQ	1315
Byd:sign	1309, 1311
Cadia	1283
CyberHome	0794
Dell	1080, 1178, 1264
Emprex	1422, 1546
Envision	0813, 1365
FlexVision	0710
Funai	0171
Go Video	0886
Hannspree	1348, 1351
Hewlett Packard	1088
HP	1088
Hyundai	0849, 1219, 1294
iLo	1286, 1603, 1990
Initial	1603, 1990
Insignia	1204, 1517, 2002
Jensen	1299
Kost	1262
LG	0856, 1178, 1993
Magnavox	1454, 0802, 1198
Marantz	0855
Maxent	0762, 1211
Mintek	1603, 1990
Mitsubishi	1250
NetTV	0762
Norcent	1365, 1589, 1591
Norwood Micro	1286, 1296
Olevia	1144, 1240, 1331, 1610
Panasonic	0650, 1941
Petters	1523
Philips	1454, 1483
Polaroid	1262, 1276, 1316, 1341, 1498, 1523
Protron	1320, 1323
Proview	1401
RCA	0047, 1958
Sampo	0762
Samsung	0812, 0766, 0814, 1395, 1575
Sansui	1409
Sanyo	1142
Sceptre	0878, 1217, 1360, 1599
Sharp	0093, 0818, 1602
Sherwood	1399
Signet	1262
Sony	0810
Sova	1320
Soyo	1520
Superscan	0864
SVA	0587, 0870, 0871
Sylvania	0171, 1271
Symphonic	0171
Syntax	1144, 1240, 1331
Tatung	1286
Techview	0847
Toshiba	0845, 1343, 1635, 1656
Ultra	1323

US Logic	1286
Vidikron	1398
Viewsonic	0857, 0864, 0885, 1330, 1578, 1627
Visart	1336
Vizio	0864, 0885, 1756
Westinghouse	0885, 0889, 0890, 1282, 1577
Wyse	1365
Zenith	1265

#### SETUP CODES FOR VCRs

ABS	1972
Admiral	0048, 0209
Adventura	0000
Aiko	0278
Aiwa	0037, 0000, 0124, 0307, 0468
Akai	0041, 0049, 0053, 0061, 0106, 0175
Alienware	1972
America Action	0278
American High	0035
Asha	0240
Audiovox	0037, 0278
Beaumarck	0240
Bell & Howell	0104
Broksonic	0184, 0121, 0209, 0002, 0211, 0295, 0361, 0479, 1479, 1815
Calix	0037
Canon	0035, 0102
Capehart	0020
Carver	0081
CCE	0072, 0278
Citizen	0037, 0278, 1278
Colt	0072
Craig	0037, 0047, 0240, 0072, 0271
Curtis Mathes	0060, 0035, 0162, 0041, 0760, 1035
Cybermex	0240, 0051
CyberPower	1972
Daewoo	0045, 0278, 0020, 0561, 0637, 1278
Daytron	0020
Dell	1972
Denon	0042
DirectTV	0739
Durabrand	0039, 0038
Dynatech	0000
Electrohome	0037
Electrophonic	0037
Emerex	0032
Emerson	0037, 0184, 0000, 0121, 0043, 0209, 0002, 0278, 1479, 1278, 0637, 1593, 0593, 0561, 0510, 0479, 0361, 0295, 0294, 0212, 0211, 0208, 0088, 0068, 0061, 0036

Fisher	0047, 0104, 0054, 0066
Fuji	0035, 0033
Funai	0000, 0593, 1593
Garrard	0000
Gateway	1972
GE	0060, 0035, 0240, 0065, 0202, 0760, 0761, 0807, 1035, 1060
Go Video	0232, 0279, 0432, 0526, 0643
GoldStar	0037, 0038, 0018, 1237
Gradiente	0000, 0408
Grundig	0195
Harley Davidson	0000
Harman/Kardon	0081, 0038, 0075
Harwood	0072, 0068
Headquarter	0046
Hewlett Packard	1972
Hi-Q	0047
Hitachi	0000, 0042, 0041, 0065, 0082, 0089, 0105, 0166
Howard Computers	1972
HP	1972
Hughes Network Systems	0042, 0739
Humax	0739
Hush	1972
iBUYPOWER	1972
Jensen	0041
JVC	0067, 0041, 0008, 0206, 0207, 0384, 1707
KEC	0037, 0278
Keen	0693
Kenwood	0067, 0041, 0038, 0384
KLH	0072
Kodak	0035, 0037
LG	1037
Linksys	1972
Lloyd's	0000, 0208
Logik	0072
LXI	0037
Magnasonic	0593, 1278
Magnavox	0035, 0039, 0081, 0000, 0149, 0110, 0563, 0593, 1593, 1781
Magnin	0240
Marantz	0035, 0081
Marta	0037
Matsushita	0035, 0162, 1162
Media Center PC	1972
MEI	0035
Memorex	0035, 0162, 0037, 0048, 0039, 0047, 0240, 0000, 0104, 0209, 0046, 0307, 0454, 0479, 1037, 1162, 1237, 1262
MGA	0240, 0043, 0061
MGN Technology	0240
Microsoft	1972
Mind	1972
Minolta	0042, 0105
Mitsubishi	0067, 0043, 0061, 0075,

	0173, 0443, 0807
Motorola	0035, 0048
MTC	0240, 0000
Multitech	0000, 0072
NAD	0058
NEC	0104, 0067, 0041, 0038, 0040, 0050, 0082
Nikko	0037
Nikon	0034
Niveus Media	1972
Noblex	0240
Northgate	1972
Olympus	0035, 0226
Onkyo	0222
Optimus	1062, 0162, 0037, 0048, 0104, 0058, 0432, 0454, 0593, 1048, 1162, 1262
Optonica	0062
Orion	0184, 0209, 0002, 0295, 0479, 1479
Panasonic	1062, 0035, 0162, 0077, 0102, 0225, 0226, 0227, 0378, 0454, 0616, 1035, 1162, 1262
Penney	0035, 0037, 0240, 0042, 0038, 0040, 0054, 1035, 1237
Pentax	0042, 0065, 0105
Philco	0035
Philips	0035, 0081, 0062, 0110, 0618, 0739, 1081, 1181
Pilot	0037
Pioneer	0067, 0058
Polk Audio	0081
Portland	0020
Presidian	1593
Profitronic	0240
Proscan	0060, 0202, 0760, 0761, 1060
Protec	0072
Pulsar	0039, 0051
Quarter	0046
Quartz	0046
Quasar	0035, 0162, 0077, 0454, 1035, 1162
RadioShack	0000, 1037
Radix	0037
Randex	0037
RCA	0060, 0240, 0042, 0149, 0058, 0065, 0077, 0105, 0106, 0202, 0760, 0761, 0807, 0880, 1035, 1060
Realistic	0035, 0037, 0048, 0047, 0000, 0104, 0046, 0062, 0066
ReplayTV	0614, 0616
Ricavision	1972
Ricoh	0034
Runco	0039
Salora	0075
Samsung	0240, 0045, 0051, 0053, 0739, 1014

Samtron	0643
Sanky	0048, 0039
Sansui	0000, 0067, 0209, 0041, 0082, 0271, 0479, 1479
Sanyo	0047, 0240, 0104, 0046, 0159
Scott	0184, 0045, 0121, 0043, 0210, 0211, 0212
Sears	0035, 0037, 0047, 0000, 0042, 0104, 0046, 0054, 0066, 0105, 1237
Sharp	0048, 0062, 0807, 0848
Shintom	0072
Shogun	0240, 0051
Singer	0072
Sonic Blue	0614, 0616
Sony	0035, 0032, 0033, 0000, 0011, 0034, 0636, 1032, 1232, 1972
Stack 9	1972
STS	0042
Sylvania	0035, 0081, 0000, 0043, 0110, 0593, 1593, 1781
Symphonic	0000, 0593, 1593
Systemax	1972
Tagar Systems	1972
Tatung	0041
Teac	0000, 0041
Technics	0035, 0162
Teknika	0035, 0037, 0000, 0052
Thomas	0000
Tivo	0618, 0636, 0739, 1996
TMK	0240, 0036, 0208
Toshiba	0045, 0043, 0066, 0210, 0212, 0366, 0845, 1008, 1145, 1972, 1996
Totevision	0037, 0240
Touch	1972
Unitech	0240
Vector	0045
Vector Research	0038, 0040
Video Concepts	0045, 0040, 0061
Videomagic	0037
Videosonic	0240
Viewsonic	1972
Villain	0000
Voodoo	1972
Wards	0060, 0035, 0048, 0047, 0081, 0240, 0000, 0042, 0072, 0149, 0062, 0212, 0760
White Westinghouse	0209, 0072, 0637
XR-1000	0035, 0000, 0072
Yamaha	0038
Zenith	0039, 0033, 0000, 0209, 0034, 0479, 0637, 1139, 1479
ZT Group	1972

# Digital Cable Self-Installation

We've included everything you'll need to hook up your new WOW! Digital Cable service, including all the equipment and step-by-step, easy-to-follow instructions.

## Digital Cable Self-Start Checklist

Please go through the contents of this kit and familiarize yourself with each item. If any equipment is missing please call WOW! toll free at 1-866-4WOW-NOW (1-866-496-9669).

The Digital Cable Self-Start kit contains:

- Digital Cable Receiver
- Digital Remote Control (with batteries)
- Receiver Power Cord
- (2) 4ft. Cable (Coaxial) Cords
- (1) 5ft. Cable (Coaxial) Cord
- 1 RCA Cord (Video/Audio Cable)

## Digital Cable Receiver Getting Started

IMPORTANT! Please review the "Important Rules for Safe Operation" section on page 56.

### Step 1: Disconnect Your Digital Adapter (existing cable box)

If you do not currently have a Digital Adapter connected, please proceed to Step 2.

- Turn off your Digital Adapter, TV and VCR.
- Unplug the Digital Adapter from the power source (wall electrical outlet).
- Unscrew and remove the main cable cord from the input plug on the back of your Digital Adapter (the other end of this cable cord should come from your wall/floor).
- Unscrew and disconnect the cable from the output plug on the back of your Digital Adapter (the other end of this cable cord should still be connected to your TV or VCR).

Your Digital Adapter is now disconnected and safe to remove.

### Step 2: Position the Digital Cable Receiver

- Take your new Digital Cable receiver out of the kit, remove any plastic wrapping, and place it where you'd like it to go in close proximity to your TV and VCR.
- Make sure you have enough room to make the necessary connections in the back of the receiver.

The Digital Cable Receiver

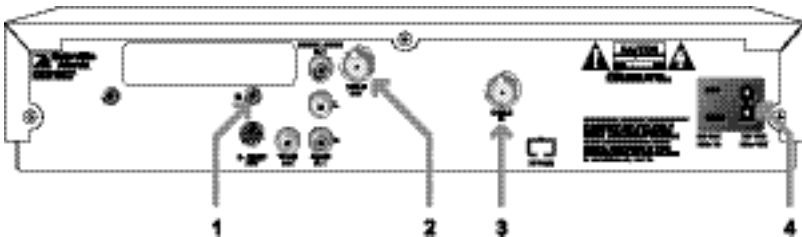

### Step 3: Connect the Digital Cable Receiver

- Determine the type of TV and VCR you have (stereo or non-stereo). If you have either a stereo TV or VCR please proceed to Step 3a; if not, please continue.
- Plug the main cable cord (coming from the wall/floor) into the “Cable In” outlet on the back of your Digital Cable receiver (receiver diagram Position 3, page E-13).
- Take the cable (coaxial) cord still connected to the TV/VCR and insert into the “Cable Out” outlet on the back of your Digital Cable receiver (receiver diagram Position 2, page E-13).

#### If you do not have a Digital Adapter:

From your kit, gather the 3 cable cords. There are two different lengths. Choose the cord that will best reach between the Digital Cable receiver and your TV/VCR.

If you are connecting a TV with a VCR:

- Take one cable (coaxial) cord and insert one end into the “Cable Out” outlet of the Digital Cable receiver and the other end into the “In” outlet of the VCR.
- Take another cable (coaxial) cord and insert one end into the “Out” outlet of the VCR and the other end into the “Cable/Antenna” outlet of the TV. (See “Advanced Equipment Setup”, page E-16, Diagram B).

If you are connecting a TV only:

- Take one cable (coaxial) cord and insert one end into the cable/antenna outlet on the TV and the other end into the “Cable Out” outlet on the Digital Cable receiver. (See “Advanced Equipment Setup”, page E-16, Diagram A).

- In your installation kit, find the power cord and plug it into the 120V AC outlet on the back of the Digital Cable receiver (receiver diagram Position 4, page E-13). If your Digital Receiver already has a power cord attached, leave outlet empty.
- Take the other end of the power cord and plug it into the power source (electrical outlet). A series of codes will appear on the front panel then the green bypass button should light up.
- Wait for the time to display on the front panel of the Digital Cable receiver (about 2 minutes).

*NOTE: If you have a more advanced setup, please refer to additional connection diagrams in “Advanced Equipment Setup,” on pages E-16 to E-17.*

#### You are now ready to turn on your system.

- Manually turn on your TV. Tune to Channel 3 (Channel 4 in Cleveland).
- Press the POWER button on your Digital Cable receiver. You should now have a clear picture on your TV. If you don’t have a clear picture, please see “Digital Cable Receiver Setup Troubleshooting” on page E-18.

### Step 3a: Stereo TV/VCR Connection

You will need to follow the steps below if you have a stereo TV or VCR.

- Find the RCA Cord in your Self-Start kit. The RCA Cord is the cable with three colored prongs at the end: yellow for Video In/Out, white for Audio In/Out L and red for Audio In/Out R.

**If you are connecting a stereo TV and a non-stereo VCR:**

- Take one end of the RCA cord and plug into the Audio Out R (red), Audio Out L (white) and Video Out (yellow) outlets on the back of the Digital Cable receiver.
- Plug the other end of the RCA cord into the Video In (yellow), Audio In L (white), and Audio In R (red) outlets on the back of your TV. (See “Advanced Equipment Setup”, page E-17, Diagram E).

**If you are connecting a stereo TV and a stereo VCR:**

IMPORTANT: You will need two RCA cords to complete this setup. You may purchase an additional RCA cord at any electronics store.

- Take one of the RCA cords and plug into the Audio Out R (red), Audio Out L (white) and Video Out (yellow) outlets on the back of the Digital Cable receiver.
- Plug the other end of the same RCA cord into the Video In (yellow), Audio In L (white) and Audio In R (red) outlets on the back of your VCR.
- Take the second RCA cord and plug into the Audio Out R (red), Audio Out L (white) and Video Out (yellow) outlets on the back of your VCR.
- Plug the other end of the second RCA cord into the Video In (yellow), Audio In L (white), and Audio In R (red) outlets on the back of your TV. (See “Advanced Equipment Setup”, page E-17 Diagram F).

*NOTE: You will not need to use any other cable cords for setting up the Digital Cable receiver.*

- Plug the main cable cord (coming from the wall/floor) into the Cable In outlet on the back of your Digital Cable receiver.
- Take the cable cord still connected to the TV/VCR and insert into the Cable Out outlet on the back of your Digital Cable receiver (only if you did not use two RCA cords or an S-Video cable in your setup).
- In your installation kit, find the power cord and plug it into the 120V AC outlet on the back of the Digital Cable receiver (receiver diagram Position 4, page E-13).
- Take the other end of the power cord and plug it into the power source (wall/electrical outlet). A series of codes will appear on the front panel then the green bypass button should light up.
- Wait for the time to display on the front panel of the Digital Cable receiver (about 2 minutes).

*NOTE: If you have a more advanced setup, please refer to additional connection diagrams in “Advanced Equipment Setup” on pages E-16 and E-17.*

**You are now ready to turn on your system.**

- Manually turn on your TV and your VCR. Tune your TV to Video 1 or Line In.
- Tune your VCR to Channel 3 (Channel 4 in Cleveland).
- Press the POWER button on your Digital Cable receiver. You should now have a clear picture on your TV. If you don't have a clear picture, please see Digital Cable Receiver Troubleshooting on page E-18.



## Advanced Digital Equipment Setup

Determine what electronic equipment you are connecting to your new digital system. Identify whether or not this equipment has stereo (TV/VCR will have Audio Out L and R outlets) or S-Video (TV/VCR will have an S-Video outlet) inputs.

### Diagram A: Connecting a Non-Stereo TV – Required Cables: 1 Coaxial Cable

NOTE: Audio output from the cable out is monaural (non-stereo).

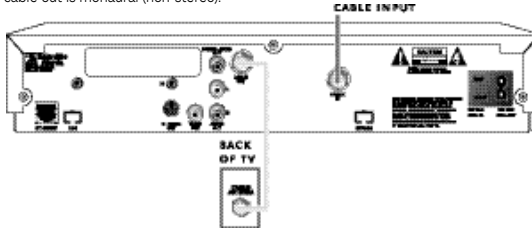

### Diagram B: Connecting a Non-Stereo TV and a Non-Stereo VCR – Required Cables: 2 Coaxial Cables

NOTE: Audio output from the Cable Out is monaural (non-stereo).

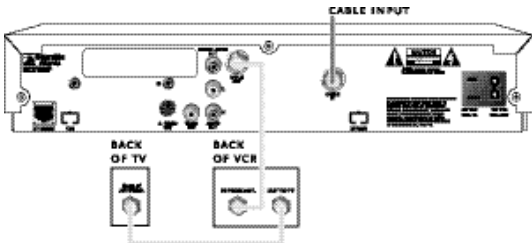

### Diagram C: Connecting a Non-Stereo TV and a Stereo VCR – Required Cables: 2 Coaxial Cables

NOTE: This setup provides monaural (non-stereo) sound only.

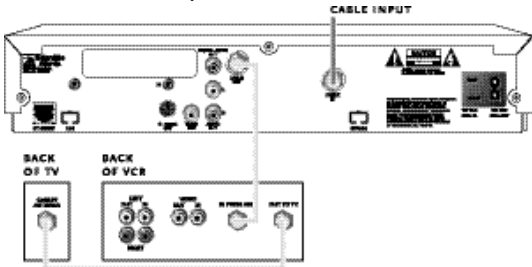

### Diagram D: Connecting a Stereo TV – Required Cables: 1 Set of RCA Cords

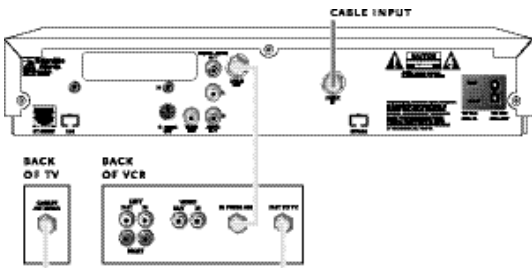

**Diagram E: Connecting a Stereo TV and a Non-Stereo VCR – Required Cables:**  
 1 Set of RCA Cords, 2 Coaxial Cables

NOTE: If you connect to S-Video Out, you must connect the Left and Right Audio Out to the Left and Right Audio In connectors on your TV, VCR or stereo (this diagram shows a stereo TV connection). Audio output from the Cable Out is monaural (nonstereo). Audio output from the Cable Out Left and Right is stereo.

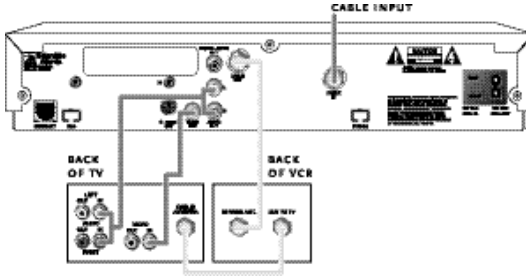

**Diagram F: Connecting a Stereo TV and a Stereo VCR – Required Cables:** 2 Sets of RCA Cords

IMPORTANT: You will need two RCA cords to complete this setup. You may purchase an additional RCA cord at any electronics store.

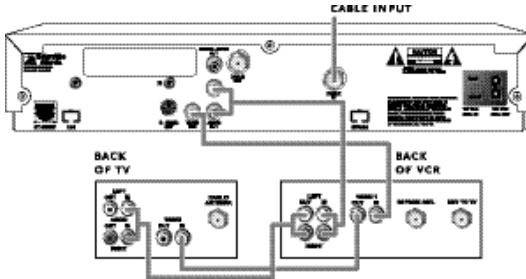

**Diagram G: Connecting a Stereo TV and a Stereo VCR with S-Video – Required Cables:** 2 S-Video Cables, 2 Stereo Audio Cables

NOTE: If you connect to S-Video Out, you must connect the Left and Right Audio Out to the Left and Right Audio In connectors on your TV, VCR or stereo.

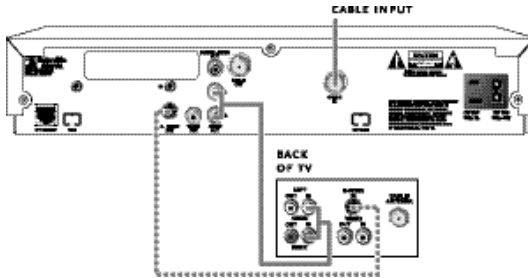

**Diagram H: Connecting a Stereo TV with S-Video – Required Cables:** 1 S-Video Cable, 1 Stereo Audio Cable

NOTE: If you connect to S-Video Out, you must connect the Left and Right Audio Out to the Left and Right Audio In connectors on your TV, VCR or stereo.

equipment/  
self-installation

## Digital Cable Receiver Setup Troubleshooting

Please walk through the troubleshooting solutions below if you do not have a picture, have a distorted picture, have no sound, or your Digital Cable receiver does not respond.

### No Picture

- Turn the TV on.
- Tune the TV to channel 3 (channel 4 in Cleveland) or Video 1, Line 1 if you used an RCA cord.
- Check to see if your TV, VCR and Digital Cable receiver are plugged into an electrical outlet that is controlled by a wall switch. If it is, make sure the switch is turned on.
- Verify that all cable cords are properly connected. You may want to walk through your connection diagram again.
- If you are using an RCA cord, make sure the VCR is on (set to Video 1 or Line 1).

### Distorted Picture or Picture “Ghosting”

- Tune the TV to channel 3 (channel 4 in Cleveland) or Video 1, Line 1 if you used an RCA cord.
- Verify that all cable cords are properly connected and tightened. You may want to walk through your connection diagram again.

### No Sound

- Check to make sure the volume is turned up on both the TV and the Digital Receiver.
- Press the TV button then the mute button. Verify that neither the mute button nor the SAP feature is activated.
- Review all suggestions from “No Picture” above.

### Digital Cable Receiver Does not Respond

- Check to see if your TV, VCR and Digital Cable receiver are plugged into an electrical outlet that is controlled by a wall switch. If so, make sure the switch is turned on.
- Verify that all cable cords are properly connected.
- Press the POWER button on the Digital Cable receiver.

### If the Remote Control Isn’t Working

This is usually because the remote control needs new batteries. Replace the existing batteries with two new AAA batteries. The Atlas remote (shown on page C-3) uses two AA batteries.

**IMPORTANT:** Replace batteries within 2 minutes of removing old ones to avoid losing programmed settings.

If you are still experiencing problems, please contact WOW! toll free at 1-866-4WOW-NOW (1-866-496-9669).

# Programming Your Digital Cable Remote Control

The Digital Remote Control is a universal remote designed to operate the features of the Digital Cable receiver. Plus, it can be programmed to control most of the basic functions of many TVs, VCRs and other devices. Inspect the front of the Digital Remote. Across the top are four buttons labeled CBL, TV, VCR, AUX (for DVDs, stereos, etc.). Pressing any of these buttons will determine which device is being controlled. The CBL button has already been pre-programmed to control the Digital Cable receiver. You will now be instructed, step-by-step, how to program the TV and VCR functions.

- 1 Check the brand names of all the devices you will be connecting to your Digital Cable system (TV, VCR, DVD, etc.). You will need the 3-digit code to program your devices. Find the codes for each device on the following pages. Write your codes here for quick reference:

TV	VCR	OTHER
<input type="text"/>	<input type="text"/>	<input type="text"/>
<input type="text"/>	<input type="text"/>	<input type="text"/>

- 2 Repeat the following steps to program each of your devices (TV, VCR, DVD, etc.).
  - Turn on the device that you want to program (using the ON/OFF button on the front of the device).
  - Press the specific device button (TV, VCR, AUX) on the remote and the SELECT button at the same time and hold for 4 seconds (the device button on the remote will light up to indicate it's ready for programming).
  - Point the Digital Remote toward the device you are programming and enter the first 3-digit code on the list for that device using the keypad number buttons. If the device is still on, try the next code listed for your brand. Continue entering codes, one at a time, until your device turns off.
  - Store the code by pressing the device button on the remote again (the device button on the remote will blink twice to confirm the code has been stored).

## To Program Your Remote to Power On Multiple Devices At Once (Power Macro)

- 1 Push the CBL button on the remote.
- 2 Simultaneously hold down SEL and ON/OFF until the CBL button lights up.
- 3 Press the device button(s) that you want to turn on (i.e. TV, VCR, and/or AUX).
- 4 Press the ON/OFF button.
- 5 Press the CH + button to store the information. Now when you press and hold down the ON/OFF button, all the devices that are programmed in will power on simultaneously.

# WOW! Digital Cable Remote Control Codes

If you're not sure which remote you have, please refer to diagrams on pages C-1 & C-3.  
Codes for the WOW! Atlas Remote shown on page C-3, can be found starting on page E-7.

## TV BRAND CODES

A Mark	112
Admiral	072 081 161
AKAI	001 146
AMPRO	073 167
ANAM	043 056 080 104 108 112 118 121
AOC	001 004 112
Candle	001 003 004
Cetronic	043
Citizen	001 003 004 101 143
Classic	043
Concerto	004
Contec	043
Coronado	143
Crown	143
Curtis Mathis	001 101 004 143
CXC	043
Daewoo	076 103 004 114 127 143
Daytron	004 143
Dynasty	043
Dynatech	062
Electrohome	024 143
Emerson	028 048 043 155 005 096 001 004 143 151 153 154
Fisher	007 057
Funai	028 043
Futuretech	043
GE	160 161 144 004 130 073 008 034 056 074 155
Goldstar	004 106 110 112 113 119 127 143
Hall Mark	004
Hitachi	163 007 004 010 011 023 075 143 158
Infinity	164
JBL	164
JCP	001
JC Penney	004 008 024 030 065 101 143 160
JVC	038 007 083 034
Kenwood	001 070
Kloss	059
KTV	043 143 154
Lodgenet	072
Loewe	164
Logik	072
Luxman	004
LXI	004
Magnavox	164 059 001 003 004 022 060 061 063 064 127
Marantz	001 164
Matsui	164
Memorex	007 072 004
MGA	001 004 024 042
Mitsubishi	004 024 040 042 109 146 191
MTC	001 004 062 101

NAD	015 025
NEC	001 130 134 040 024 056 019
Nikei	043
Onking	043
ONWA	043
Optonica	019 081
Panasonic	034 056 080 164
Philco	001 003 024 056 059 060 063 064 127 143 164 004
Philips	164 093 038 005 001 003 004 059
Pioneer	025 135 004 023 076
Portland	004 143
Proscan	144 160 161 167
Proton	171 173 004 143
Quasar	034 056
Radio Shack	004 019 043 127 143
RCA	016 161 065 156 144 001 004 023 024 056 074 152
Realistic	007 019
Runco	072 169
Sampo	001 004 192
Samsung	004 101 127 133 143 160
Sanyo	007 057 082
Scott	004 028 043 048 143
Sears	094 015 028 030 004 007 057 082 143 160
Sharp	019 081 028 014 004 022 143 175
Signature	072
Sony	070 085 139 126
Soundesign	028 004 003 043
Spectricon	112
SSS	004 043
Sylvania	001 003 059 060 063 064 164 160 127
Symphonic	052
Tandy	081
Tatung	056 062
Technics	034 080
Techwood	004
Teknika	003 004 024 028 043 072 101 143
Telerent	072
Tera	172
TMK	004
Toshiba	015 003 040 062 101
Totevision	143
Universal	008
Video Concepts	146
Vidikron	174
Vidtech	004
Wards	004 008 019 028 060 061 064 072 074 164
Yamaha	004
York	004
Yupiteru	043

Zenith	072 073 095 103
Zonda	112
<b>VCR BRAND CODE</b>	
AIWA	034 161
AKAI	043 046 124 142 146
AMPRO	072
ANAM	031
Audio Dynamics	012 023 043
Broksonic	035 037 129
Canon	028 031
Capehart	108
Craig	001 040 135
Curtis Mathis	031 041
Daewoo	117 005 010 017 108 111
Daytron	108
DBX	012 023 043
Dynatech	034 053
Electrohome	059
Emerson	006 029 035 153 017 025 027 031 034 036 037 046 101 129 131 138
Fisher	001 009 010
Funai	034
GE	031 063 072 107 109 144 147
Go Video	132 136 003
Goldstar	004 112 020 101 123
Harmon Kardon	012 045
Hitachi	026 150 018 034 043 063 137
Instantreplay	031
JCL	031
JC Penney	004 012 040 101
Jenson	043
JVC	031 043 048 055 060 130 150 152 012
Kenwood	014 034 048 047
Lloyd	034
LXI	034 001 004 009 017 101
Magin	040
<b>VCR BRAND CODE</b>	
Magnavox	067 031 034 041 068 154 156
Marantz	067 069 012 031
Marta	101
Matsui	027
MEI	031
Memorex	040 101 001 010 014 031 034 053 072 134 139
MGA	045 046 059
Minolta	004 020
Mitsubishi	059 061 004 020 046 051 142
MTC	034 040
Multitech	024 034
NEC	012 023 043 048

Nordemende	043
Optonica	053 054
Panasonic	031 070 133 140
Pentax	004 002 031 063
Philco	031 034 067
Philips	031 067 034 054 101
Pilot	101
Pioneer	004 021 048
Portland	108
Pulsar	072
Quartz	014
Quasar	031 070 140
Radio Shack	101 123
RCA	144 147 107 109 031 004 020 034 040 041 141 158
Realistic	001 008 010 014 031 034 040 053 054 101
Ricoh	058
Runco	072
Salora	014
Samsung	017 040 107 109 113 115 124

#### VCR BRAND CODE

Sansui	043 048 135
Sanyo	001 010 040 014 134
Scott	017 037 129 131
Sears	017 081 001 004 008 009 010 014 020 101
Sharp	053 031 054 157 159
Shintom	024
Sony	056 057 058 001 009 031 052 053 155 002
Soundesign	034
STS	004
Sylvania	031 034 059 067
Symphonic	034
Tandy	010 034
Tatung	043
TEAC	034 043
Technics	031 070
Teknika	031 034 101
Thomas	034
TMK	006
Toshiba	017 131 004 008 059 082 150 047
Totevision	040 101
Unitech	040
Vector Research	012
Video Concepts	012 034 043 141
Videosonic	040
Wards	001 004 017 024 031 034 040 053 054 131
Yamaha	012 034 043
Zenith	072 034 048 056 058 080 101 153

#### STEREO BRAND CODE

3M	123
ADC	200
ADCOM	072 082 092 161

AIWA	025 071 104 114 170
AKAI	138
AMC	125 126 127
ANAM	019 081
Angstrom	142
Arcam	141
Audio Access	147
Audio Alchemy	135
Audiofile	203
B&K	096 097
Bose	070 071
BSR	210
California Audio	205
Capetronic	215
Carver	003 008 027 028 053 061 099 151 212
Casio	204 208 211 213 223 224
Chiro	140
Cinema Sound	001 134
Citation	148
Clarinette	208 211 224
Clarion	026
Curtis Mathis	204
CXC	043
Denon	001 105 155 196 199
Eiger	149
Fisher	008 151
Fosgate Audionics	062 157
Fraba	213 226
Genexxa	206 214
Haitai	005
Harmon Kardon	028 153 154 157 162
Hitachi	020
Inkel	005
JC Penney	102204
Jensen	058
JVC	013 163 176 177 178
Kenwood	005 008 057 146 166
Krell	150
Kyocera	200
Lexicon	120 167 171 172
Linn	124
Luxman	035 137 139 165
LXI	078 204
Magnavox	152 164 212
Marantz	027 036 087 212
Mcintosh	173
MCS	204
Memorex	214 219
MGA	202
Mission	212
Mitsubishi	180 202
Modulaire	208 211 224
NAD	048
Nakamichi	111 182 183
Niles	185
NSM	212
Onkyo	046 107 108
Optimus	206 214 219
Panasonic	007 195 205

Parasound	129 130 132
Philips	087 188 189 191 212
Pioneer	014 033 039 045 050 054 069 090 160 068 206 214 219
Proceed	144
Proton	207 212
Quasar	205
Radio Shack	211 224
RCA	010 117 156
Realistic	078 081 208 209
Runco	072 169
Rotel	074 083 085 212
SAE	212
Samsung	201
Sansui	027 110 111 119 198 212
Sanyo	151
Scott	019 081
Sears	204
Sharp	026 057 094
Sherwood	024 038
Sony	018 052 055 084 101 186 187
Soundesign	036
SSI	068
STS	200
Sylvania	212

#### STEREO BRAND CODE

Symphonic	209
Tandy	214 219
TEAC	019 059 081 111
Technics	007 076 088 122 193 205
TOSHIBA	112
VICTOR	013 063
WARDS	008
YAMAHA	021 026 031 067 192
YORX	208 211 224
ZENITH	143

equipment/  
self-installation

DVD BRAND	CODE
Alpine	145
Apex Digital	194 218
Denon	169 244
GE	248 249
Harmon Kardon	184
Hitachi	154
JVC	255
LG	175 217 253
Magnavox	222 243
Marantz	181 221
Mitsubishi	245
Myryad	158
NAD	197
Nakamichi	159
Onkyo	179 251
Panasonic	246 252
Philips	221 243
Pioneer	241 247 146
Proceed	190
Proscan	248 249
RCA	248 249
Samsung	242 254
Sharp	220
Sony	250
Tatung	158
Thompson	248 249
Toshiba	174 251
Yamaha	216 252
Zenith	175 217 253

LDP BRAND	CODE
Daewoo	023
Denon	236
Goldstar	233
Kenwood	231
Lotte	232
Magnavox	232
Optimus	238
Panasonic	227
Philips	232
Pioneer	226
RCA	237
Realistic	238
Samsung	229
Sharp	231
Sony	228
Technics	227
Toshiba	231
Yamaha	239

TIVO BRAND	CODE
Philips	133
Sony	136

# WOW! digital video recorder (dvr) information

## Controlling Live TV

### Control a Live Program You Are Watching

The PAUSE, REWIND, FAST-FORWARD, PLAY, INSTANT REPLAY, and LIVE keys on the remote control are used to control the live program in the Main screen (also known as full-screen TV). These same keys are known as the dedicated DVR keys. For example, when you are watching your favorite program and the telephone rings, press PAUSE to pause the program for up to 1 hour, and then press REWIND or FAST-FORWARD to reverse or advance one frame at a time. To resume watching your favorite program, press PLAY, and then press REWIND or FAST-FORWARD to cycle through three different speeds of rewind or fast-forward. To replay the last 8 seconds of a program, press INSTANT REPLAY. And to watch the live program currently in progress, press LIVE.

Note: Use these same dedicated DVR keys to control the reduced screen (also known as the quarter screen) in the program guide and in all DVR screens.

### Pause a Live Program

The paused status bar appears when you press PAUSE.

## Recording TV Programs

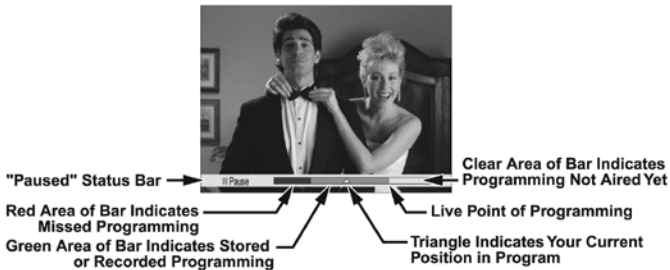

### Record a TV Program You Are Watching

- 1 Press RECORD.
- 2 While in the Confirm Recording screen, press SELECT to record your TV program.  
*Note: The Record Indicator is lit on the front panel of the DVR receiver*
- 3 To stop recording, press STOP and then follow the on-screen choices.

### Record a TV Program From the Program Guide

- 1 Press GUIDE.
- 2 Press the arrow keys to highlight a TV program, and then press RECORD.
- 3 In the Confirm Recording screen, press A to record the TV program. Note: The recording program is highlighted in the program guide.





## Record Episodes of a TV Program

- 1 To record a single episode or all episodes of a TV program, press GUIDE.
- 2 Highlight a TV program, and then press RECORD.
- 3 While in the Confirm Recording screen, press to select more recording options.
- 4 While in the Edit Recording screen, press the arrow keys to make your selections.  
*Note: The title of the fourth column will change based upon your selections of single episode or all episodes.*
- 5 Press the "A" button to save your selections.



## Using Picture-In-Picture (PIP)

### Activate PIP On Your TV

While watching a program, press the dedicated PIP ON key to activate the PIP screen.

*Notes:*

- You can only use the dedicated DVR keys to control the program shown in the Main screen.
- To change the channel in the PIP screen, use the dedicated PIP CH+ and CH- keys.
- To pause or record the video in the PIP screen, swap it to the Main screen.

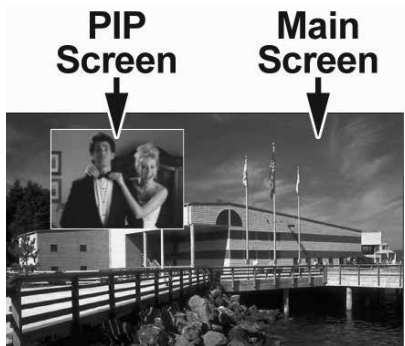

### Activate PIP From The Program Guide

From the program guide, press EXIT to close the program guide, and then press PIP ON.

### Swap The Main and PIP Screens

To swap the TV program that is in the PIP screen to the Main screen, press the dedicated PIP SWAP key.

*Note: You will only hear the audio for the program shown in the Main screen.*

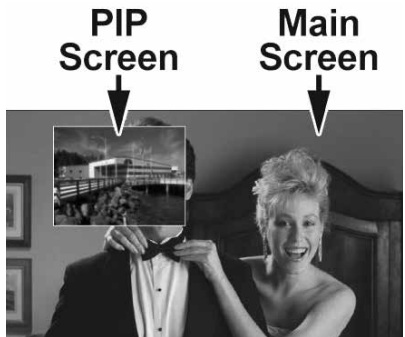

### Move The PIP Screen

To move the PIP screen to a different corner of the Main screen, press the dedicated PIP MOVE key. You can move the PIP screen to any of the four corners of the Main screen.



## Frequently Asked Questions

### **How far back can I rewind live TV?**

The length of time you can rewind live TV depends on how long you have been watching a single channel. Each time you change channels, a new copy is stored to the built-in recorder. If you have been watching the same channel for 15 minutes, you can rewind for 15 minutes.

### **Can I record the video in the PIP screen?**

Yes, but swap it into the Main screen first. After pressing RECORD and confirming the recording, you can swap it back into the PIP screen and it will continue recording. You can also press the dedicated PIP OFF key and the video will continue to record.

### **If I've been tuned to a program since it started, do I have to rewind to the beginning to record the entire program?**

No, if you have been tuned to the program since its beginning, just press RECORD from any point in the program to record the entire program.

### **How will I know the Digital Video Recorder is almost out of recording space?**

When you are viewing the list of your recorded programs, press the "B" (Preferences) button. This will show you how much recording space has been used.

### **Can you playback more than one recording?**

No, you cannot playback more than one recording at a time.

### **What happens if my Digital Video Recorder loses power temporarily?**

Everything you have recorded is saved, based on the save time selected in the Edit Recording screen. Your scheduled recordings during the time the Digital Video Recorder lost power are the only recordings you may miss.

### **Do my Program Guide Parental Controls carry over to DVR recordings?**

Yes, if you block programs by channel or rating in General Settings, those settings are carried over to DVR recordings. For example, if you decide to block all R-rated programs in General Settings, the R-rated programs will still be recorded, but you cannot play them back until you enter the correct PIN.

### **Do I need my remote control to set or playback a recording?**

No, you can use the front panel of the Digital Video Recorder to schedule a recording from the program guide, or press the LIST key to access and playback your recorded programs.

### **Can I copy recorded programs to a VCR?**

Yes. Simply choose Copy to VCR from the Recorded Program Options menu and follow the onscreen instructions to record to your VCR. (Note: WOW! does not provide the cables for this type of connection, please refer to your VCR manual for the correct cables to use with your VCR).

### **Can I record only new episodes of my favorite show?**

Yes. Just choose New first-run episodes on this channel from the Recording Options menu to record new episodes only.

### **Why do I have to power on my DVR each morning?**

The DVR has a power saving mode. Between 1:15 am and 6:00 am the DVR will enter a power saving mode if it is inactive. This will not affect the scheduled recordings that may be set.

### **Will the DVR automatically erase programs I have recorded?**

The DVR can be set to auto erase the oldest programs that are recorded if desired. To turn this feature on, access the Preferences menu and select Turn ON Auto-Erase.

# WOW! HD reference guide

## Welcome!

Congratulations on adding the WOW! HD Set-top to your television viewing experience!

WOW! HD Set-tops provide you the ability to view cable television programming for high-definition television (HDTV) as well as standard-definition television (SDTV).

## Before you Begin

- Read the IMPORTANT RULES FOR SAFE OPERATION below.
- If you plug the set-top into an outlet that is controlled by a wall switch, keep the switch in the ON position. The on-screen guide is updated nightly. If the wall switch is in the OFF position, your set-top will not receive the latest programming updates.
- Keep the top of the set-top free of all objects and electronic devices, including your TV.
- It is recommended that you connect a surge protector to your cable equipment and electronic devices.

## Important Rules for Safe Operation

### Read and Retain These Instructions

- Read all of the instructions before you operate the set-top. Give particular attention to all safety precautions. Retain the instructions for future reference.
- Comply with all warning and caution statements in the instructions. Observe all warning and caution symbols that are affixed to this set-top.
- Comply with all instructions that accompany the set-top.

### Placement

Place this set-top in a location that is close enough to an electrical outlet to accommodate the length of the power cord. Place set-top on a stable surface. The surface must support the size and weight of the set-top.

### Ventilation

This set-top has openings for ventilation that protect it from overheating. To ensure the reliability of the set-top, follow these guidelines to avoid obstruction the openings:

- Do not place other equipment, lamps, books, or any other object on the top of this set-top.
- Do not place this set-top in any of the following locations:
  - On a bed, sofa, rug or similar surface
  - Over a radiator or a heat register
  - In an enclosure, such as a bookcase or equipment rack, unless the installation provides proper ventilation.

## Cleaning the Set-Top

Before cleaning this set-top, unplug it from the electrical outlet. Use a damp cloth to clean. Do not use a liquid cleaner or an aerosol cleaner. Do not use a magnetic/static cleaning device (dust remover).

## Object and Liquid Entry

Never push objects of any kind into this product through openings as they may touch dangerous voltage points or short out parts that could result in a fire or electric shock. Do not expose this set-top to liquid or moisture. Do not place set-top on a wet surface. Do not spill liquids on or near set-top.

## Accessories

Do not use accessories with this set-top unless recommended by your cable service provider.

## Overloading

Do not overload electrical outlets, extension cords, or integral convenience receptacles, as this can result in a risk of fire or electric shock. For equipment that requires battery power or other sources to operate, refer to the operating instructions for that equipment.

## Lightning and Power Surges

Ground your cable system to provide some protection against voltage surges and built-up static charges. Plug your set-top into a surge protector to reduce the risk of damage from lightning strikes and power surges. If you have questions, call WOW! at 1-866-4WOW-NOW (1-866-496-9669).

## Power Cord Protection

Arrange all power cords so that people cannot walk on the cords, place objects on the cords, or place objects against the cords, which can damage the cords. Give particular attention to the cords at the point at which the cord connects to the plug, at electrical outlets, and at the places where the cords exit the set-top.

## Power Sources

A label on this set-top indicates the correct power source for this set-top. Operate this set-top only from an electrical outlet that has the voltage and frequency that the label indicates. If you are unsure of the type of power supply to your residence, consult your cable service provider or your local power company.

## Grounding

This set-top has a two-prong plug. Properly ground this set-top by inserting the plug into a grounded electrical, two-socket outlet. If this plug is polarized, it has one wide prong and one narrow prong. This plug fits only one way.



### **CAUTION:**

**To prevent electric shock, match wide blade of plug to the wide slot, and then fully insert.**

If you are unable to insert this plug fully into the outlet, contact an electrician to replace your obsolete outlet.

## Servicing

Do not open the cover of this set-top. If you open the cover, your warranty will be void. Refer all servicing to qualified personnel only. Contact us for instructions.

### Damage that Requires Service

For damage that requires service, unplug this set-top from the electrical outlet. Contact WOW! when any of the following occurs:

- There is damage to the power cord or plug
- Liquid enters the set-top
- There is exposure to rain or water
- Operation is not normal (the instructions in this guide describe the proper operation)
- Set-top is dropped or damaged
- Set-top exhibits a distinct change in performance



Upon completion of any service or repairs to this set-top, the WOW! service technician will perform safety checks to determine that the equipment is in proper operating condition.

### Screen Burn-In Warning

Please refer to the user's guide that came with your high-definition television (HDTV) for an important message regarding images being permanently "burned in" to your HDTV screen.

## Connecting the Set-Top

Follow these steps using the connection diagrams on the following pages to connect your HD Set-top box to your HDTV and other devices.



### WARNING:

**Electric Shock hazard! Unplug all electronic devices before connecting or disconnecting any device cables.**

- 1 Unplug all electronic devices before connecting the set-top.
- 2 Connect the set-top to your HDTV, VCR, and other devices as shown in the diagrams later in this guide.  
(The diagrams in this guide do not cover every possible wiring combination.)
- 3 Connect the set-top to the coaxial cable coming from the wall.
- 4 Plug the set-top and the TV into an AC power source, but do not turn on your set-top or HDTV yet.
- 5 Wait for the front of your set-top to display one of the following:
  - Current time
  - Four dashes(----)

*Important: It may take several minutes for the set-top to receive the latest software, programming and service information. When the front panel displays the time or four dashes, the update is complete.*

- 6 After the update is complete, press POWER to turn on your set-top.
- 7 Turn on the power to your HDTV.
- 8 Press the Input or TV/Video key on the HDTV remote or on the HDTV and scroll to the video input you chose for the connection. For example: Video 6.

## Wiring a HD Receiver

The following 2 diagrams display how a HD Receiver should be connected to a HDTV.

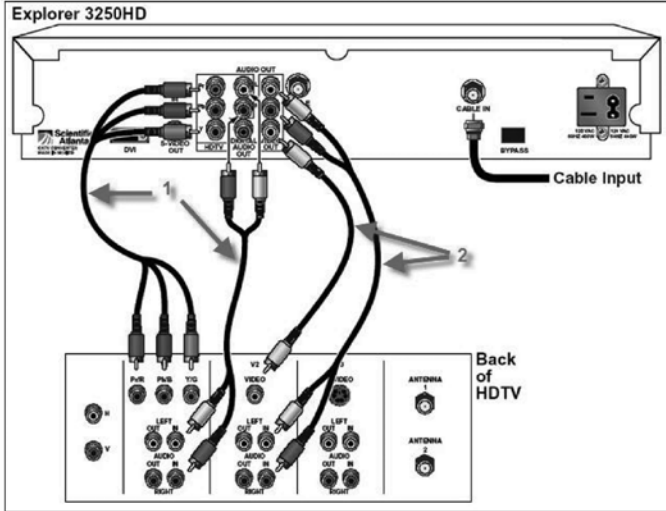

1. Component/Composite Stereo Cables - For HD picture.
2. Composite Cables - For SD picture.

## HDMI (High Definition Multimedia Interface)

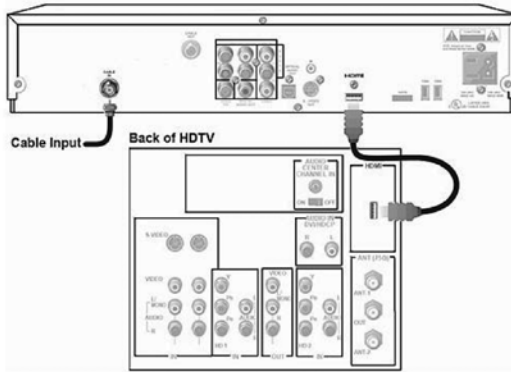

## HDTV Formats

Most HDTVs include YPbPr connectors for component video inputs, and your HD Set-Top includes a YPbPr cable for these inputs. However, some HDTVs only have RGB inputs. If you have one of these HDTVs, you may need an RGB adapter. Check with us for information about receiving an RGB adapter. Also, some SDRVs include YPbPr inputs. Your HD set-top will function correctly with these inputs only when outputting in 480i mode.

## Audio Output

To hear stereo sound, you must do one of the following:

- Connect stereo audio cables from the AUDIO OUT LEFT and RIGHT connectors on the set-top to the AUDIO IN LEFT and RIGHT connectors on your HDTV.
- Connect an RCA cable from the DIGITAL AUDIO OUT on your set-top to the DIGITAL AUDIO IN on your HDTV (if equipped) or stereo receiver.

In addition, you may also connect an S-Video cable from the S-VIDEO OUT connector on the set-top to the S-VIDEO connector on the HDTV or VCR. However, the S-VIDEO connection does not supply audio. You must also use audio cables with the S-Video cable.

If you connect the set-top to your HDTV using only the coaxial cable at the CABLE OUT connection, your HDTV will not receive stereo sound from your set-top.

*Note: S-Video and coaxial cables only deliver SDTV programming. They do not deliver HDTV programming.*

## Using the Set-Top







After you set up your HD Set-Top, and the front panel displays the current time, you can turn on the set-top and begin watching TV. Press the POWER button on the front of the set-top to turn it on. We will send nightly programming updates to your set-top (such as program guide information). You should leave your set-top on at all times so that it can receive these updates.

### Basic Remote Control Keys

- To turn the set-top on, press TV and then POWER.
- To change the channel, use CH+ and CH-.
- To adjust the volume, use VOL+ and VOL-.
- To view more information about the current program, press INFO.

### Interactive Program Guide

The Interactive Program Guide organizes programs and events into listing by channel, theme, or title. The current channel continues to display in the upper right corner of the guide. The upper left corner displays information about the highlighted program.

- To view or hide the guide, press Guide.
- To view information about a program, use the arrow keys on the remote control     to highlight program.
- To view more information about the highlighted program press INFO.
- To view the highlighted program, press SELECT.
- The    keys provide additional functions that vary, based on the current menu screen. The functions assigned to each of these keys is shown on the bottom of the screen.
- To format the picture size if you have WOW! HD, please refer to the gray box on page C-7.

## Setting Menu Options

### Set-Top Menu Settings

The HD Set-Top offers the following two menu settings that you can use to configure your set-top features, based on your preferences:

- The Quick Settings menu gives you quick access to the more commonly used settings such as parental control, favorite channel lists, and sleep times.
- The General Settings menu gives you access to all of the quick settings plus advanced settings, such as on-screen languages and Personal Identification Numbers (PINs)

### To Access the Menus:

- Press SETTINGS once to view the Quick Settings menu. Press SETTINGS again to view the General settings menu. Press SETTINGS a third time to hide both settings menus.
- Use the arrow keys to scroll through the settings options.
- Press SELECT to change the highlighted setting.
- Press INFO to learn more about the highlighted setting.

## Troubleshooting

If your set-top does not function as expected, read the following conditions and suggestions. If the situation persists, contact your cable service provider.

### Questions About the Set-Top

If your set-top does not perform as expected, check the following conditions:

- Verify that the power to your TV is turned on.
- If plugged into a wall switch, verify the switch is in the ON position.
- Verify that all cables are properly connected.
- Verify that your TV is connected to the proper TV input port.

If your set-top does not perform as expected after checking the power, the cables, and the output channel, check the following conditions:

### No picture

- If your system includes a VCR or stereo, verify that you have properly connected them to the set-top.
- Verify that the set-top Power light is on and the Bypass light is off.

### No color

- Verify that the current TV program is broadcast in color.
- Adjust the TV color controls.

### No sound

- If your setup includes a VCR or stereo, verify that you have properly connected them to the set-top
- Verify that the volume is turned up.
- Verify that the Bypass feature is disabled.

The TV Screen displays a message indicating that the set-top is automatically updating its software. Wait for the time to appear on the front panel of your set-top before continuing with the installation process. When the front panel displays the time, the update is complete.



## United States FCC Compliance

This equipment has been tested and found to comply with the applicable limits of Part 15 of FCC Rules. These limits are designed to provide reasonable protection against harmful interference in residential installation. This equipment generates, uses, and can radiate radio frequency energy and, if not installed and used in accordance with the instructions, may cause harmful interference to radio or TV reception, which can be determined by turning the equipment off and on. The user is encouraged to try to correct the interference by one or more of the following measures:

- Increase the distance between the equipment and receiver.
- Connect the equipment into an outlet on a circuit different from that to which the receiver is connected.
- Consult an experienced radio/TV technician or WOW! for help.

Any changes or modifications not expressly approved by Scientific-Atlanta could void the user's authority to operate the equipment.

*Important: The information shown in the FCC Declaration of Conformity paragraph below is a requirement of the FCC and is intended to supply you with information regarding the FCC approval of this device. The phone numbers listed are for FCC-related questions only and not intended for questions regarding the connection or operation for this device. Please contact WOW! for any questions you may have regarding the operations or installation of this device.*

## Software and Firmware Use

Scientific-Atlanta, Inc. owns copyrights to the software included in your set-top and furnishes the software to your cable service provider under a license agreement. You may only use or copy this software in accordance with the terms of your cable service provider.

Scientific-Atlanta, Inc. owns copyrights to the firmware in this equipment. You may only use the firmware in the equipment in which it is provided. Any reproduction or distribution of this firmware, or any portion of it, without the express written consent of Scientific-Atlanta, Inc. is prohibited.

## Trademarks

Explorer, Scientific-Atlanta, and the Scientific-Atlanta, Inc. VCR Commander and "Bringing the Interactive Experience Home" are trademarks of Scientific-Atlanta, Inc.

## FCC Declaration of Conformity

This device complies with Part 15 of FCC Rules. Operation is subject to the following two conditions:

- 1 the device may not cause harmful interference, and
- 2 the device must accept any interference received, including interference that may cause undesired operation.

Explorer® Digital Interactive Set-Top model: Model 3250HD  
 Manufactured by: Scientific-Atlanta, Inc.; • 5030 Sugarloaf Parkway; • Lawrenceville, Georgia 30042; USA  
 Telephone 770-236-1077 • (Terms and Conditions Revised as of September 2004)

# digital adapter – self-install instructions

It's simple to install the Digital Adapter. Just follow the five easy steps and you'll be on your way to enjoying the digital experience.

## Step A: Connect the Digital Adapter to the cable outlet

1. Find the coax cable that runs from the cable wall outlet to your TV.
2. Disconnect the coax cable from your TV.
3. Connect this cable to the “Cable In” port on the back of the Digital Adapter.
4. Leave the other end of this cable plugged into the cable wall outlet.

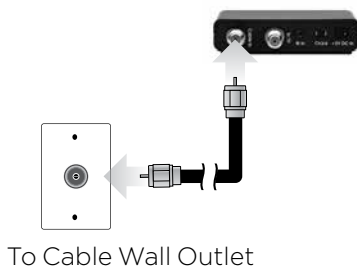

## Step B: Connect the coax cable from the Digital Adapter to the TV

1. Take the coax cable provided in your self-install kit.
2. Connect one end to the “To TV” port on your Digital Adapter and connect the other end to the “Cable In” or “RF In” port on your TV.

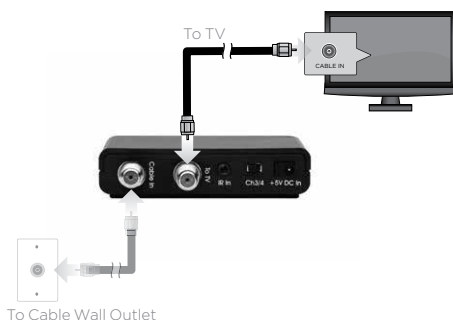

## Step C: Connect the power cord

1. Take the power cord provided in your self-install kit.
2. Connect the power cord to the electrical wall outlet and the “+5V DC In” port on the Digital Adapter.

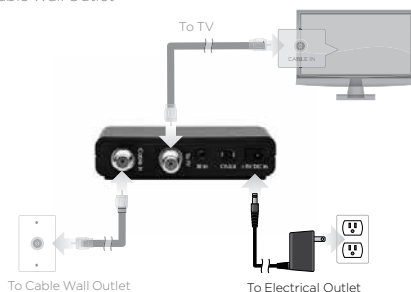

## Step D: Set the channel

1. Turn on your TV and tune it to channel 3 (Channel 4 in Cleveland area).
2. Make sure the channel “3/4” switch on the Digital Adapter is set to the same channel as your TV.

If you don't have a picture after completing the activation steps, you may need to switch your TV and Digital Adapter to channel 4.



## Step E: Activating your Digital Adapter

Once you have connected your Digital Adapter(s), they are ready to be activated, which will authorize your Digital Adapter(s) to begin receiving signals from WOW!'s network and send cable channels to your TV. Once your Digital Adapter(s) are activated you will be able to enjoy your WOW! Cable.

All Digital Adapter's must be connected prior to activation.

To activate your Digital Adapter(s), visit [www.wowdigitaladapter.com](http://www.wowdigitaladapter.com) or call 1-888-268-5872.

## Programming Your Remote

Program your remote to sync with your TV model.

1. Get remote instructions manual from self-install kit. Find the brand name and 3-digit device code number of your TV. For example, Panasonic TV: 005, 006, 007, 008.
2. Manually turn on the TV.
3. Confirm the batteries are correctly inserted in the remote.
4. Press and hold the "Set" button. Then, while holding down "Set", press the Power button. The LED light will turn red, indicating the remote is in program mode. Release both buttons.
5. Enter the 3-digit Device Code (for example: code 005 under Panasonic TV). The red LED light turns off if the code has been accepted by the remote control.
6. If the LED light flashes twice, it means the code entered is incorrect, and the remote control remains in program mode. Re-enter the correct code number again. The remote will exit program mode if the code is not entered within 10 seconds.
7. Point the remote towards the TV and press the Power button. If the TV turns off, the remote is now programmed to operate the TV.
8. If the TV fails to turn off, go back to Step 1 and enter the next code listed under the TV brand.

## Digital Adapter Troubleshooting

### How do I program my VCR to record using a WOW! Digital Adapter?

To record a program using your Digital Adapter and VCR:

1. Set your VCR to record channel 3 (4 in Cleveland) for the time the program is airing.
2. Tune the Digital Adapter to the channel you want to record.

The VCR can only record the channel that your Digital Adapter is tuned to. To record different programs at different times, you will need to change the channel on your Digital Adapter.

### My Digital Adapter takes too long to change the channels. What can you do about that?

We understand that the experience may be different from what you are used to. Unfortunately, there may be a slight delay when you are changing channels as the Adapter works to tune from one digital signal to the next.

### My Digital Adapter remote stopped working, loses its programming or won't power off/on.

If your remote loses its programmed codes, try replacing the batteries with high quality Alkaline batteries. When replacing the batteries, try not to push any buttons, and the codes should remain intact.

For a list of Frequently Asked Questions, visit [wowway.com](http://wowway.com).