

Pitched roof waterproofing



BMI Coverland

www.bmigroup.com/za

EasyFlash®

A simple and effective retrofit solution to ensure a home space that is comfortable and protects what you care about, no matter what the weather outside.

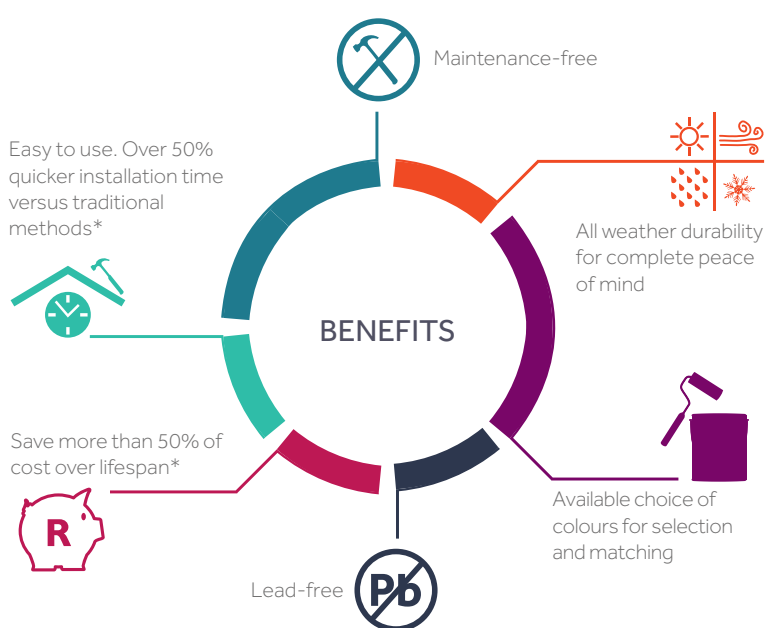

* Based on analysis with 50 merchants and truss manufacturers

EasyFlash® is an innovative, dry-fix waterproofing solution specifically designed to replace traditional metal flashing for abutments and junctions between walls and roof tiles. Manufactured with a butyl self-adhesive backing and a crêped, aluminium surface. The highly flexible (up to 50% stretch) structure enables neat, fast, effortless fitment. EasyFlash® is extremely durable, lasting for up to 15 years in all weather conditions, maintenance-free with Connection Strip applied.

The Connection Strip is screwed onto the EasyFlash® and the wall to provide additional sealing against water ingress due to paint peeling. The top end is then sealed with a suitable weather resistant silicon sealant.

APPLICATIONS ON TILED ROOFS

- Side and horizontal wall connections
- Dormers
- Chimneys**

**Not suitable for metal chimney applications due to rising temperatures of above 80°C and no surface area to apply Connection Strip.

COMPONENTS

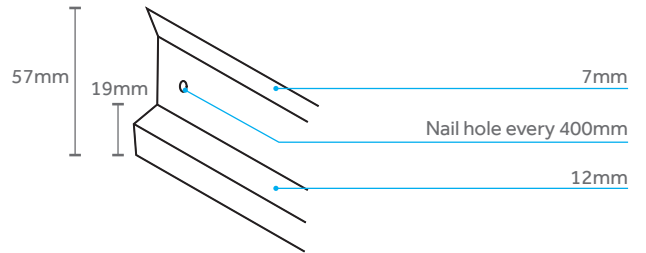
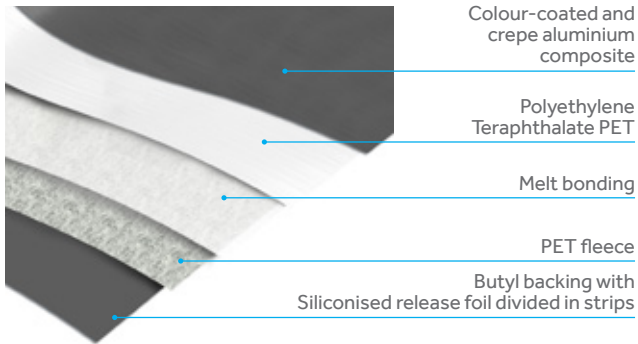

EASYFLASH®

Material Aluminium composite (Aluminium Foil, Polyethylene Teraphthalate PET, Melt bonding & PET fleece), Butyl backing & siliconised release foil.

Roll dimensions (m) 5 (L) x 0.25 (W)

Stretch factor up to 50%

Surface Colours Brown / Black / Terracotta

Recommended to seal with Connection Strip in accordance with application instructions

CONNECTION STRIP

Material Clean colourbond steel

Dimensions (m) 2.4 (L) x 0.6 (W)

Colour Double-sided brown & terracotta

APPLICATION

Preparation

Ensure that the tile surface is dry, free from dirt and dust. Plastered walls must first be primed and painted.

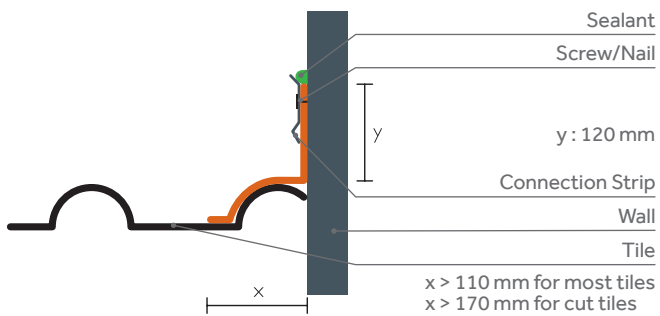



Coverland

BRANCHES

Bloemfontein	051 492 0210
Brits	010 492 8800
Cape Town	021 492 2230
Durban	031 565 3260
East London	043 492 0041
Germiston	010 492 8780
Nelspruit	013 492 1930
Polokwane	015 495 0070
Port Elizabeth	041 492 0130
Richards Bay	035 797 2160

BMI Coverland (Pty) Ltd

Block 6
Constantia View Office Estate
2 Hogsback Avenue
Quellerina
011 222 7300
info.sa@bmigroup.com

www.bmigroup.com/za

As of April 2017, Coverland forms part of the BMI Group. The BMI Group, a Standard Industries company, is the largest manufacturer of flat and pitched roofing and waterproofing solutions throughout Europe. With 128 production facilities and operations in Europe, parts of Asia and South Africa, the company brings more than 165 years of experience. For more information visit www.bmigroup.com

Our expertise and innovations are bringing advantages in sustainability, performance and architectural design to residential, commercial, and public sector projects. Our product offering integrates functionality, energy efficiency and aesthetics for the homeowner. As the largest concrete roof tile manufacturer in Southern Africa, our reach expands across 8 production facilities and 4 depots nationally.