

# Stainless steel slide H36" - simple (ASTM/CSA)

EP-SL-SS36-W1

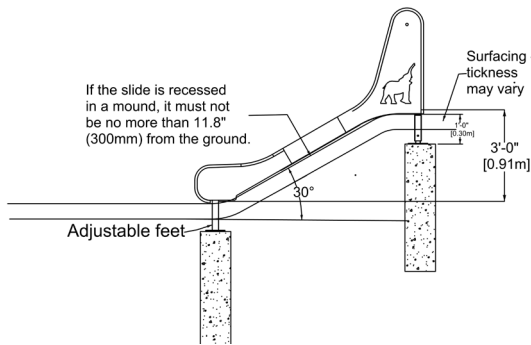
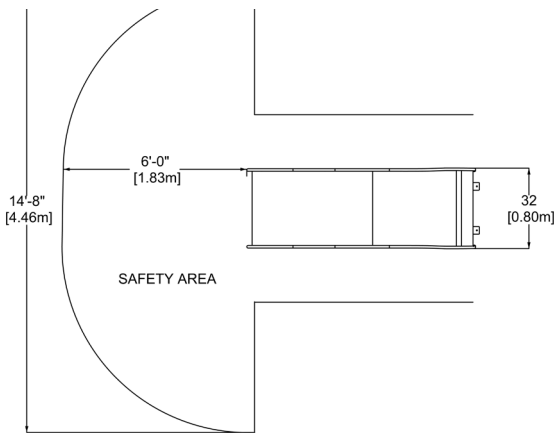

### CHARACTERISTICS

Stainless steel slide.  
Width: 32"  
Height (slide): 3'-0" (0.91m)  
Clearance area: 14'-8" x 6' (4.46m x 1.83m)

Safety zone to be validated if it is an embankment slide.

### MATERIALS

Polished stainless steel.

### INSTALLATION METHOD

Adjustable legs fix to 12" concrete sonotubes.

### PLAY VALUE

The slide promotes the proprioceptive system.

\* A stainless steel slide should **always face north** to avoid overheating the surface from the sun.

### INSTALLATION DETAILS

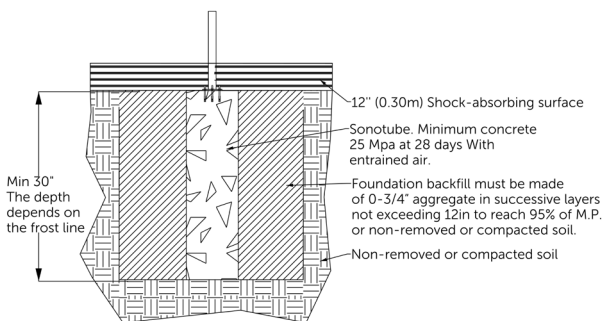

### AVAILABLE COLORS - PAINT

\* The structure can be painted but the price reflects bare stainless steel construction throughout the structure.

