

Bouncing Mat

EP-ES-EA4000 (ASTM & CSA)

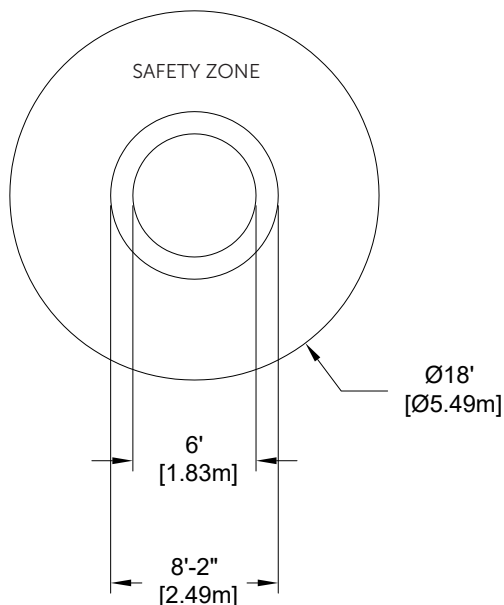
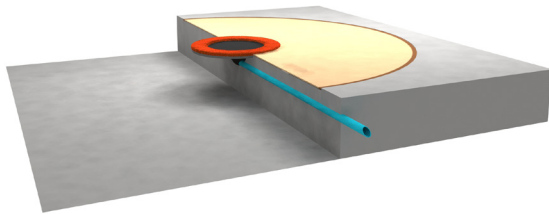
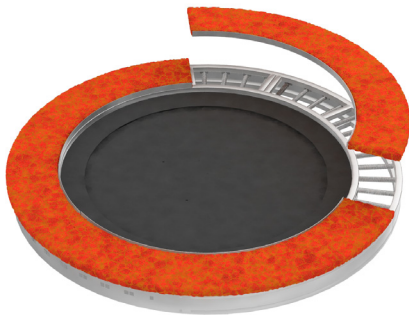
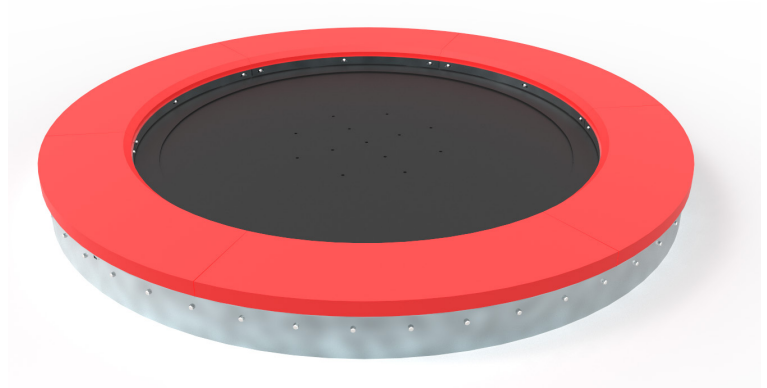

CHARACTERISTICS

Age Group: 2-5 years old

Fall Height: 0' (0m)

Capacity: 5

Safety Zone US (ASTM) and Canada (CSA): Ø18' (Ø5,49m)

MATERIALS

Inner Structure: Heavy-Duty Galvanized Steel;

Protection Ring: Galvanized Steel covered with poured-in-place EPDM rubber mat;

Central Mat: 1/2" (1.27cm) reinforced natural rubber.

ANCHORS TYPE

In-ground Galvanized Steel freestanding footings.

PLAY VALUE

The Bouncing Mat offers an opportunity to enhance general playful freedom of movement, enhance stability, coordination and global motricity skills. It creates high sensory stimulation thanks to the feeling given by each bounce. Challenge stimulates and develops the user's vestibular and proprioceptive systems by jumping or bouncing activity.

AVAILABLE COLORS - BORDER

