

# Seventy Bench configuration 3

EP-UFS-S70.C3

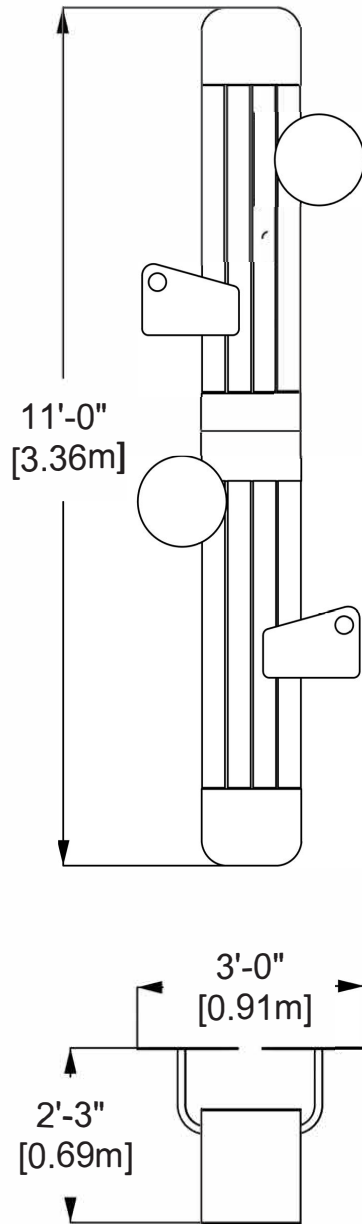
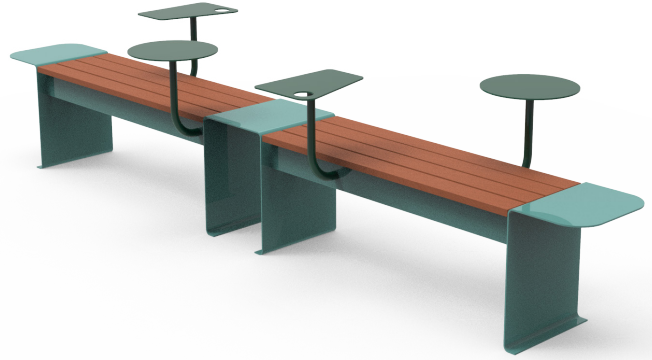

### CHARACTERISTICS

Assembly of 2 straight sections and 4 individual tables.

This assembly is designed to correspond to the aesthetics of the post-modern movement of which Charles Daudelin was a part. The shapes of the tables and the aesthetics of the whole are inspired by his work on the facade of the Leonard-de Vinci School, in Montreal.

Dimensions: 11' x 3' x 2'3" [3.36m x 0.91m x 0.69m]

### MATERIALS

Structure and tables: 0.5" thick bent zinc-plated steel and painted with baked-on electrostatic paint.

Seats: recycled plastic slats or wood. The price may vary depending on the material selected.

### ANCHORS TYPE

Four 1/2" diameter mechanical anchors in a concrete slab. An anchor-cover covers the anchors for a better finish.

### AVAILABLE COLORS - STRUCTURE

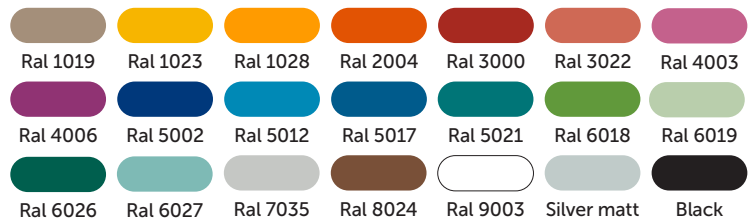

### AVAILABLE COLORS - SURFACES

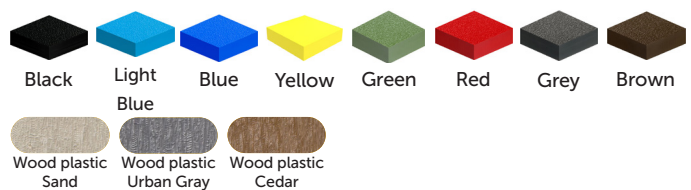

### AVAILABLE WOOD

