

# Seventy Bench configuration 4

EP-UFS-S70.C4

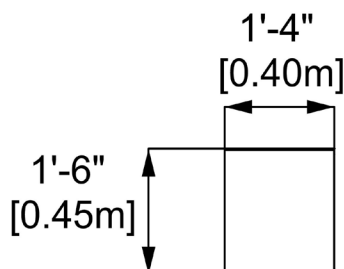
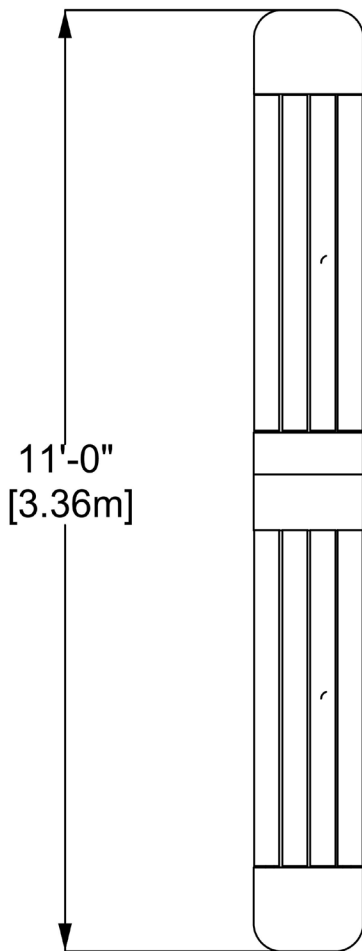

### CHARACTERISTICS

Assembly of 2 straight sections.

This assembly is designed to correspond to the aesthetics of the post-modern movement of which Charles Daudelin was a part. The shapes of the tables and the aesthetics of the whole are inspired by his work on the facade of the Leonard-de Vinci School, in Montreal.

**Dimensions:** 11' x 3' x 1'4" [3.36m x 0.45m x 0.40m]

### MATERIALS

**Structure:** 0.5" thick bent zinc-plated steel and painted with baked-on electrostatic paint.

**Seats:** recycled plastic slats or wood. The price may vary depending on the material selected.

### ANCHORS TYPE

Four 1/2" diameter mechanical anchors in a concrete slab. An anchor-cover covers the anchors for a better finish.

### AVAILABLE COLORS - STRUCTURE

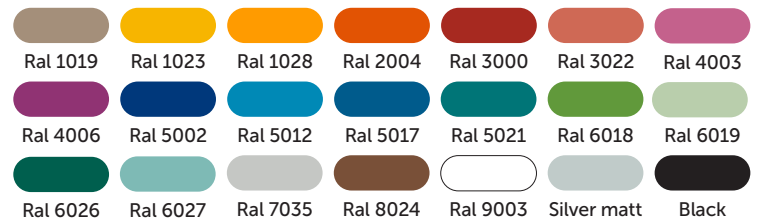

### AVAILABLE COLORS - SURFACES

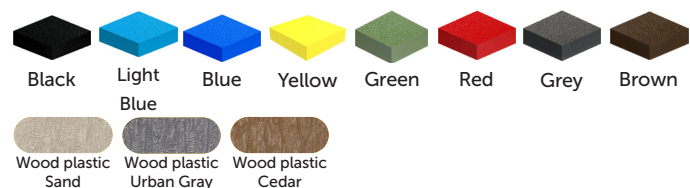

### AVAILABLE WOOD

