

# Triple Arch Swing

EP-ES-ES3000 (CSA)



To verify product certification, visit [www.ipema.ca](http://www.ipema.ca).



## CHARACTERISTICS

Age Group : 5-12 years old  
 Critical Height : 9'-2" (2,79m)  
 Fall Height : 6'-8" (2,02m)  
 Capacity : 12  
 Safety Zone : 42'-9" x 32'-6" (13,02m x 9,91m)

## MATERIALS

Structure : powder coated galvanized steel;  
 Cables : braided UV-resistant nylon over seven (7) galvanized steel cables; 0,8" (20mm) diameter;  
 Saucer Swing Seat : aluminum;  
 Bumper : resistant and shock absorbing rubber.

## ANCHORS TYPE

In-ground galvanized steel freestanding footings.

## PLAY VALUE

An opportunity to enhance playful freedom of movement. This swing admits multiple users, favorizing social development, enhancing its play value over traditional swings. This type of play equipment gives high sensory stimulation created by its range of motions. The challenge provided by the swing stimulates and develops the user vestibular system and proprioceptive system by following the equipment's unique movement.

## AVAILABLE COLORS - PAINT

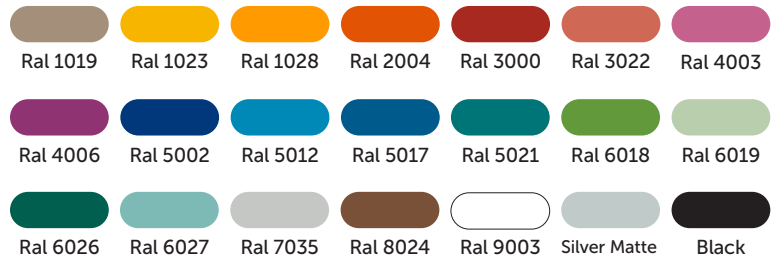

## AVAILABLE COLORS - CABLES



## AVAILABLE COLORS - BUMPER

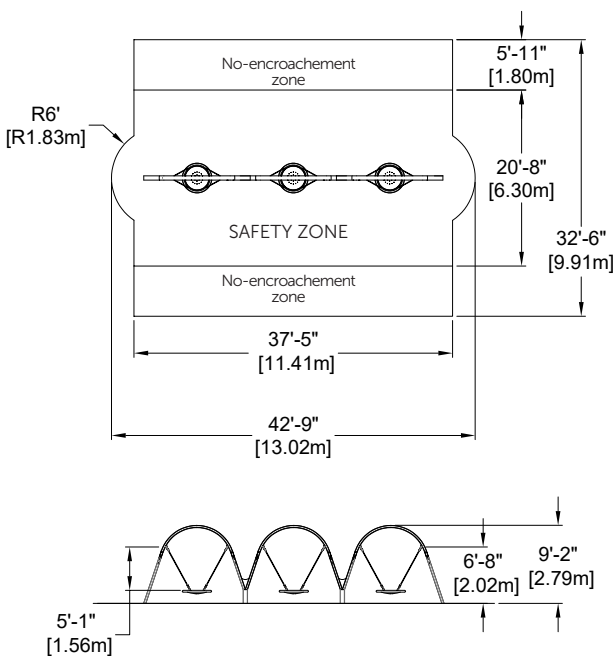
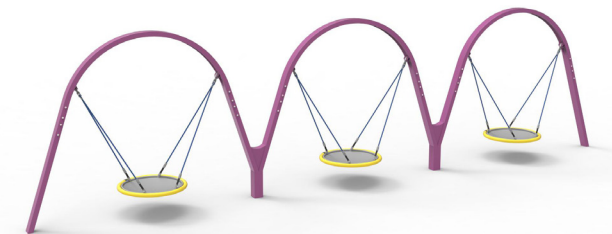

ELEPHANT PLAY

1-877-854-3319

info@elephantplay.com

elephantplay.com