







TEST REPORT IEC 60884-1 Plugs and socket-outlets for household and similar purposes Part 1: General requirements	
Report Number.....	: 201000070SHA-001
Date of issue.....	: 2020-11-12
Total number of pages	: 66
Name of Testing Laboratory	
preparing the Report	: Intertek Testing Services Shanghai
Applicant's name	
	: LUMI LEGEND ELECTRICAL CO., LTD.
Address.....	
	: No 18, Lane 239, Beihai Road, Jiangbei, Ningbo, 315032 CHINA
Test specification:	
Standard	: IEC 60884-1:2002, AMD1:2006, AMD2:2013
Test procedure	: S-mark
Non-standard test method	: N/A
Test Report Form No.	
	: IEC60884_1G
Test Report Form(s) Originator	
	: IMQ S.p.A.
Master TRF	
	: Dated 2019-05-07
Copyright © 2019 IEC System of Conformity Assessment Schemes for Electrotechnical Equipment and Components (IECEE System). All rights reserved. This publication may be reproduced in whole or in part for non-commercial purposes as long as the IECEE is acknowledged as copyright owner and source of the material. IECEE takes no responsibility for and will not assume liability for damages resulting from the reader's interpretation of the reproduced material due to its placement and context. If this Test Report Form is used by non-IECEE members, the IECEE/IEC logo and the reference to the CB Scheme procedure shall be removed. This report is not valid as a CB Test Report unless signed by an approved CB Testing Laboratory and appended to a CB Test Certificate issued by an NCB in accordance with IECEE 02.	
General disclaimer:	
The test results presented in this report relate only to the object tested. This report shall not be reproduced, except in full, without the written approval of the Issuing CB Testing Laboratory. The authenticity of this Test Report and its contents can be verified by contacting the NCB, responsible for this Test Report.	

Test item description :	Plug, rewirable	
Trade Mark :		
Manufacturer	Same as applicant	
Model/Type reference :	602247	
Ratings :	16A 250V~ IP44	
Responsible Testing Laboratory (as applicable), testing procedure and testing location(s):		
<input checked="" type="checkbox"/>	Testing Laboratory:	Intertek Testing Services Shanghai
	Testing location/ address :	Building No.86, 1198 Qinzhou Road (North), Shanghai 200233, China
	Tested by (name, function, signature) :	Jimmy Ma 
	Approved by (name, function, signature) :	Justin Zhang  justin.zhang
<input type="checkbox"/>	Testing procedure: CTF Stage 1:	
	Testing location/ address :	
	Tested by (name, function, signature) :	
	Approved by (name, function, signature) :	
<input type="checkbox"/>	Testing procedure: CTF Stage 2:	
	Testing location/ address :	
	Tested by (name + signature)	
	Witnessed by (name, function, signature) . :	
	Approved by (name, function, signature) :	
<input type="checkbox"/>	Testing procedure: CTF Stage 3:	
<input type="checkbox"/>	Testing procedure: CTF Stage 4:	
	Testing location/ address :	
	Tested by (name, function, signature) :	
	Witnessed by (name, function, signature) . :	
	Approved by (name, function, signature) :	
	Supervised by (name, function, signature) :	

List of Attachments (including a total number of pages in each attachment):	
N/A	
Summary of testing:	
We conclude that the products described in this test report comply with the standard according to the testing results on the submitted samples.	
Tests performed (name of test and test clause):	Testing location:
All clauses of IEC 60884-1:2002 (Third Edition) + A1:2006+A2:2013.	Intertek Testing Services Shanghai. Building No.86, 1198 Qinzhou Road (North), Shanghai 200233, China
Summary of compliance with National Differences (List of countries addressed):	
Sweden	
<input checked="" type="checkbox"/> The product fulfils the requirements of SS 428 08 34:2013+R1:2017+T1:2018	
Copy of marking plate:	
 	
602247	
16/250~ IP44	
Earthing terminal marked with: 	

Test item particulars.....:	
Standard Sheet	CEE 7 / VII + SS 4280834 / VIIb
Rated current (A) / Rated voltage (V)	16A/250V~
Degree of protection against access to hazardous parts and against harmful ingress of solid foreign objects	IP4X
Degree of protection against harmful ingress of water	IPX4
Provision for earthing	with earthing contact
Method of connecting the cable	rewirable
Type of cable	N/A
Nominal cross-sectional areas (mm²)	N/A
Type of terminals	Screw-type
Type of connections	N/A
Socket-outlets:	
Degree of protection against electric shock :	N/A
Existence of shutters	N/A
Method of application / mounting of the socket-outlet	N/A
Method of installation	N/A
Intended for circuits where	N/A
Plugs:	
Class of equipment	I
Possible test case verdicts:	
- test case does not apply to the test object.....	N/A
- test object does meet the requirement.....	P (Pass)
- test object does not meet the requirement.....	F (Fail)
Testing.....:	
Date of receipt of test item	2020-10-09
Date (s) of performance of tests	2020-10-09 ~2020-11-12
General remarks:	

"(See Enclosure #)" refers to additional information appended to the report.
 "(See appended table)" refers to a table appended to the report.

Throughout this report a comma / point is used as the decimal separator.

This report is for the exclusive use of Intertek's Client and is provided pursuant to the agreement between Intertek and its Client. Intertek's responsibility and liability are limited to the terms and conditions of the agreement. Intertek assumes no liability to any party, other than to the Client in accordance with the agreement, for any loss, expense or damage occasioned by the use of this report. Only the Client is authorized to permit copying or distribution of this report and then only in its entirety. Any use of the Intertek name or one of its marks for the sale or advertisement of the tested material, product or service must first be approved in writing by Intertek. The observations and test results in this report are relevant only to the sample tested. This report by itself does not imply that the material, product, or service is or has ever been under an Intertek certification program.

Determination of the test conclusion is based on IEC Guide 115 in consideration of measurement uncertainty.

Manufacturer's Declaration per sub-clause 4.2.5 of IEC 60335-1:

The application for obtaining a CB Test Certificate includes more than one factory location and a declaration from the Manufacturer stating that the sample(s) submitted for evaluation is (are) representative of the products from each factory has been provided

- Yes
- Not applicable

When differences exist; they shall be identified in the General product information section.

Name and address of factory (ies) : LUMI LEGEND ELECTRICAL CO., LTD.
 No 18, Lane 239, Beihai Road, Jiangbei, Ningbo, 315032, CHINA

General product information and other remarks:

16A 250V~, Class I, rewirable, IP44, comply with standard sheet CEE 7/VII+ SS 4280834/VIIb, with pillar-type terminals, with non-solid pins, with TPR enclosure, with longitudinal cord entry.

Remarks:

1. The samples for each group of testing were selected randomly from the samples provided by the manufacturer.
2. The test results reported in this test report shall refer only to the sample actually tested and shall not refer or be deemed to refer to bulk from which such a sample may be said to have been obtained.
3. We conclude that the product presented in this test report complies with the standard according to the test results on the submitted samples.
4. This report is based on original test report no. 151000029SHA-001 except Sweden deviation was updated in this test report. After the evaluation, only clauses 9, 14 & 27 and Sweden deviation should be conducted again.

List of insulating and critical components:

Object / part No.	Manufacturer/ trademark	Type / model	Technical data	Standard	Mark(s) of conformity
Enclosure	YUYAO XINGWANG PLATICS CHEMIC.CO.LTD	-	TPR	IEC 60884-1, SS 428 0834	Test with appliance
Insert	FORMOSA PLASTICS CORPORATION	-	PP 1080	IEC 60884-1, SS 428 0834	Test with appliance

IEC 60884-1			
Clause	Requirement + Test	Result - Remark	Verdict
8	MARKING		
8.1	Accessories marked as follows:		P
	- rated current (A)	16	P
	- rated voltage (V)	250	P
	- symbol for nature of supply	~	P
	- manufacturer's or responsible vendor's name	Refer to page 2	P
	- type reference	Refer to page 2	P
	- degree of protection (first characteristic numeral) if higher than 2	IP4X	P
	- degree of protection (second characteristic numeral) if higher than 0	IPX4	P
	- degree of protection (first characteristic numeral) higher than 4 for fixed socket outlet in which case the second characteristic numeral shall also be marked		N/A
	- degree of protection (second characteristic numeral) higher than 2 for fixed socket outlet in which case the first characteristic numeral shall also be marked		N/A
	Socket-outlets with screwless terminals marked with the following:		N/A
	- the length of insulation to be removed		N/A
	- an indication of the suitability to accept rigid conductors only (if any)		N/A
8.2	Symbols used: as required in the standard		P
	Marking for the nature of supply placed next to the marking for rated current and rated voltage		P
8.3	Marking of fixed socket-outlets placed on the main part:		N/A
	- rated current, rated voltage and nature of supply		N/A
	- identification mark of the manufacturer or of the responsible vendor		N/A
	- length of insulation to be removed, if any		N/A
	- indication of the suitability to accept rigid conductors only for screwless terminals for those socket-outlets having this restriction		N/A
	- type reference		N/A
	Cover plates necessary for safety purposes and intended to be sold separately: marked with the manufacturer's or responsible vendor's name and type reference		N/A

IEC 60884-1			
Clause	Requirement + Test	Result - Remark	Verdict
	IP code, if applicable: marked so as to be easily discernible		N/A
	Fixed socket-outlets classified according to item b) of 7.2.5: identified by a triangle visible after installation unless they have an interface configuration different from that used in normal circuits		N/A
8.4	Plugs and portable socket-outlets: marking specified in 8.1, other than the type reference, easily discernible		P
	Plugs and portable socket-outlets for equipment of class II not marked with the symbol for class II construction		N/A
8.5	Neutral terminals: N		N/A
	Earthing terminals: [earth symbol]		P
	Markings not placed on screws or other easily removable parts		P
	Terminals for conductors not forming part of the main function of the socket-outlet:		N/A
	- clearly identified unless their purpose is self-evident, or		N/A
	- indicated in a wiring diagram fixed to the accessory		N/A
	Identification of such terminals may be achieved by:		N/A
	- their being marked with graphical symbols according to IEC 60417-2 or colours and/or alphanumeric system, or		N/A
	- their being marked with their physical dimensions or relative location		N/A
8.6	Surface-type mounting boxes forming an integral part of socket-outlets having an IP code higher than IP4X, or higher than IPX2, the IP code marked on the outside of its associated enclosure so as to be easily discernible		N/A
8.7	Indication of which position or with which special provision the declared IP of flush-type and semi-flush-type fixed socket-outlets having IP>X0 is ensured		N/A
8.8	Marking durable and clearly legible with normal or corrected vision, without additional magnification. Test: 15 s with water and 15 s with petroleum spirit	moulding	P
9	CHECKING OF DIMENSIONS		

IEC 60884-1			
Clause	Requirement + Test	Result - Remark	Verdict
9.1	Accessories and surface-type mounting boxes comply with the appropriate standard sheets and corresponding gauges, if any	See Annex	P
	Insertion of plugs into fixed or portable socket-outlets ensured by their compliance with the relevant standard sheets		P
	Compliance checked by measurement and by means of gauges with manufacturing tolerances as shown in table 2	See Annex	P
9.2	It is not possible to engage a plug with:		P
	- a socket-outlet having a higher voltage rating or a lower current rating;		P
	- a socket-outlet with a different number of live poles (exception admitted provided that no dangerous situation can arise);		P
	- a socket-outlet with earthing contact, if the existing plug of the present national system is a plug for class 0 equipment;		N/A
	Engagement of an existing plugs on the present national system for equipment of class 0 or of class I with a socket-outlet exclusively designed to accept plugs for class II equipment		P
	Impossibility of insertion checked by applying a gauge, for 1 min, with a force of:		P
	- 150 N (rated current \leq 16A);		P
	- 250 N (rated current $>$ 16A)		N/A
	Accessories with elastomeric or thermoplastic material: test carried out at (35 ± 2) °C		P
9.3	Deviations from standard sheets made only if they provide technical advantage and do not affect the purpose and safety of accessories complying with standard sheet		N/A

10	PROTECTION AGAINST ELECTRIC SHOCK		
10.1	Live parts not accessible, even after removal of parts which can be removed without the use of a tool for:		P
	Fixed socket-outlets		N/A
	Plugs when the plug is in partial or complete engagement with a socket-outlet		P
	Test with test probe B of IEC 61032		P
	Accessories with elastomeric or thermoplastic material: additional test carried out at (35 ± 2) °C with test probe 11 of IEC 61032 (75 N for 1 min)		P

IEC 60884-1			
Clause	Requirement + Test	Result - Remark	Verdict
	During the test: accessories not deform and no live parts accessible		P
	Plugs and portable socket-outlets pressed with a force of 150 N for 5 min as shown in figure 8: specimens not show deformation		P
10.2	Accessible parts (with exception of small screws and the like for fixing main parts and covers or cover plates): made of insulating material		P
	Cover or cover plates of fixed socket-outlets and accessible parts of portable socket-outlets: made of metal if the requirements of 10.2.1 or 10.2.2 are fulfilled		N/A
10.2.1	Accessible metal parts or accessible metal parts protected by supplementary insulation made by insulating linings or insulating barriers		N/A
	Insulating linings or insulating barriers cannot be removed without being permanently damaged		N/A
	Insulating linings or insulating barriers cannot be replaced in an incorrect position and, if they are omitted, accessories are rendered inoperable or manifestly incomplete		N/A
	There is no risk of accidental contact between live parts and metal covers or cover plates		N/A
10.2.2	Accessible metal parts are reliably connected, through a low-resistance connection, to the earth during fixing		N/A
10.3	Contact between a pin of a plug and a live socket-contact of a socket-outlet not possible while any other pin is accessible		P
	Compliance checked by manual test and by means of gauges with tolerances as specified in table 2		P
	Accessories with elastomeric or thermoplastic material: test carried out at $(35 \pm 2) ^\circ\text{C}$		P
	Socket-outlets with enclosure or bodies of rubber or polyvinyl chloride: test carried out with a force of 75 N for 1 min		N/A
	Fixed socket-outlets provided with metal covers or cover plates: clearance of at least 2 mm required between a pin and a socket-contact when another pin(s) is(are) in contact with the metal covers or cover plates (mm)		N/A
10.4	External parts of plugs made of insulating material		P
	Overall dimensions of rings around pins not exceed 8 mm concentric with respect to the pin		N/A

IEC 60884-1			
Clause	Requirement + Test	Result - Remark	Verdict
10.5	Shuttered socket-outlets: live parts not accessible, without a plug in engagement, with the gauges shown in figure 9 and 10		N/A
	Live contacts automatically screened when the plug is withdrawn		N/A
	Shutters so designed that a plug is inserted with the same movement in a socket outlet with shutters as in a socket-outlet without shutters		N/A
	Means cannot easily be operated by anything other than a plug and not depend upon parts which are liable to be lost		N/A
	Gauge of figure 9, applied to the entry holes corresponding to live contacts with a force of 20 N, for approximately 5 s, successively in three directions, does not touch live parts		N/A
	Steel gauge of figure 10, applied to the entry holes corresponding to live contacts with a force of 1 N for approximately 5 s, in three directions, does not touch live parts		N/A
	Accessories with elastomeric or thermoplastic material: test carried out at $(35 \pm 2) ^\circ\text{C}$		N/A
10.6	Earthing contacts of a socket-outlet designed that they cannot be deformed by the insertion of a plug		N/A
	Test plug inserted into the socket-outlet with a force of 150 N for 1 min		N/A
10.6	Earthing contacts of a socket-outlet designed that they cannot be deformed by the insertion of a plug		N/A
	After this test: socket-outlet still comply with the requirements of clause 9		N/A
10.7	Socket-outlet with or without lid with increased protection: live parts not accessible		N/A
	Test wire of 1 mm diameter (figure 10) applied with a force of 1 N on all accessible surfaces does not touch live parts		N/A
	Accessories with elastomeric or thermoplastic material: test carried out at $(35 \pm 2) ^\circ\text{C}$		N/A
	Socket-outlet tested without a plug inserted with the lid, if any, open		N/A
11	PROVISION FOR EARTHING		
11.1	Earth connection made before the current-carrying contacts of the plug become live		P
	Current-carrying pins are separated before the earth connection is broken		P

IEC 60884-1			
Clause	Requirement + Test	Result - Remark	Verdict
11.2	Earthing terminals of rewirable accessories comply with clause 12		P
	Earthing terminals of the same size as the corresponding terminals for the supply conductors		P
	Earthing terminals of rewirable accessories: internal		P
	Earthing terminals of fixed socket-outlets: fixed to the base or to a part reliably fixed to the base		N/A
	Earthing contacts of fixed socket-outlets:		N/A
	- fixed to the base, or		N/A
	- fixed to the cover (reliably connected to the earthing terminals; contact pieces silver plated or with adequate protection)		N/A
	Parts of earthing circuit in one piece or reliably connected by riveting, welding, or the like	In one piece	P
11.3	Accessible metal parts of fixed socket-outlets: permanently and reliably connected to the earthing terminal		N/A
11.4	Socket-outlets, having an IP>X0, with enclosure of insulating material and more than one cable inlet, provided with:		N/A
	- an internal fixed earthing terminal, or		N/A
	- adequate space for a floating terminal (test connection using the type of terminal specified by the manufacturer), unless		N/A
	- earthing terminal of socket-outlet itself allows the connection of an incoming and an outgoing earthing conductor		N/A
11.5	Connection between earthing terminal and accessible metal parts: of low resistance		N/A
	Test current equal to 1,5 times the rated current or 25 A (A)		—
	Resistance not exceed 0,05 Ω (Ω)		N/A
11.6	Fixed socket-outlets according to item b) of 7.2.5: earthing socket contact and its terminal electrically separated from any metal mounting means or other exposed conductive parts which may be connected to the protective earthing circuit of the installation		N/A

12	TERMINALS AND TERMINATIONS		
	All the test on terminals, with the exception of the tests of 12.3 11 and 12.3.12, made after the test of clause 16		P
12.1	General		P

IEC 60884-1			
Clause	Requirement + Test	Result - Remark	Verdict
12.1.1	Rewirable fixed socket-outlets provided with screw-type terminals or with screwless terminals		N/A
	Rewirable plugs and portable socket-outlets provided with terminals with screw clamping	Screw terminal for earthing terminals and live terminals	P
	Pre-soldered flexible conductors used: pre-soldered area outside the clamp area of screw-type terminals		N/A
	Clamping means of terminals: not serve to fix any other components		P
12.1.2	Non-rewirable accessories provided with soldered, welded, crimped or equally effective permanent connections (termination)		N/A
	Screwed or Snap-On connections not used		N/A
	Connections made by crimping a pre-soldered flexible conductor not permitted		N/A
12.2	Terminals with screw clamping for external copper conductors		P
12.2.1	Accessories provided with terminals which allows the proper connection of copper conductors as shows in table 3		P
	Rated current (A); Type of accessories	16A; 2P+E	—
	Type of conductor (rigid / flexible)	flexible	—
	Smallest / largest cross-sectional area (mm ²)	0,75 / 1,5	—
	Diameter of the largest conductor (mm)	1,8 (Sweden deviation)	—
	Figure of terminal	Figure 2	—
	Minimum diameter D (minimum dimensions) of conductor space: required (mm); measured (mm) .:	required: 2,5mm; measured:2,91mm	P
12.2.2	Terminals allow the conductor to be connected without special preparation		P
12.2.3	Terminals have adequate mechanical strength		P
	Screws and nut for clamping the conductors have metric ISO thread or a comparable thread		P
	Screws not of soft metal such as zinc or aluminium		P
12.2.4	Terminals resistant to corrosion		P
12.2.5	Terminals clamp the conductor(s) without undue damage	See appended table 12.2.5	P
	During the test: conductor not slip out, no break near clamping unit and no damage		P
12.2.6	Terminals clamp the conductor reliably between metal surfaces	See appended table 12.2.6	P
	During the test: conductor not move noticeably		P

IEC 60884-1			
Clause	Requirement + Test	Result - Remark	Verdict
12.2.7	Terminals designed or placed that the conductor cannot slip out while the clamping screws or nuts are tightened	See appended table 12.2.7	P
	After the test: no wire of the conductor escaped from the clamping unit		P
12.2.8	Terminals not work loose from their fixing to accessories		P
	Torque test (screws and nuts tightened and loosened 5 times):		P
	- rated current (A)	16A	—
	- copper conductor of the largest cross-sectional area (mm ²) (table 3)	1,5	—
	- type of conductor (solid or stranded)	Solid	—
	- torque (Nm) (table 6 or appropriate figures 2, 3 or 4)	0,5	—
	During the test: terminals not work loose and show no damage		P
12.2.9	Clamping screws or nuts of earthing terminals: adequately locked against accidental loosening, not possible to loosen them without the aid of a tool		P
12.2.10	Earthing terminals: no risk of corrosion		P
	Body of brass or other metal no less resistant to corrosion		P
	The body is a part of a frame or enclosure of aluminium alloy: precautions are taken to avoid the risk of corrosion		P
12.2.11	Pillar terminals: distance <i>g</i> no less than the value specified in figure 2: required (mm); measured (mm)	Required: 1,5mm Measured: >2mm	P
	Mantle terminals: distance <i>g</i> no less than the value specified in figure 5: required (mm); measured (mm)		N/A
12.3	Screwless terminals for external copper conductors		N/A
12.3.1	Screwless terminals of the type suitable for:		N/A
	- for rigid copper conductors only, or		N/A
	- for both rigid and flexible copper conductors (tests carried out with rigid and then repeated with flexible conductors)		N/A
12.3.2	Screwless terminals provided with two clamping units each allowing the proper connection of rigid or of rigid and flexible conductors having nominal cross-sectional areas from 1,5 up to 2,5 mm ² (table 7)		N/A

IEC 60884-1			
Clause	Requirement + Test	Result - Remark	Verdict
	Two conductors to be connected: each conductor introduced in a separate clamping unit		N/A
12.3.3	Screwless terminals allow the conductor to be connected without special preparation		N/A
12.3.4	Parts of screwless terminals intended for carrying current of materials as specified in 26.5		N/A
12.3.5	Screwless terminals clamp specified conductors with sufficient contact pressure without undue damage to the conductor		N/A
	Conductor clamped between metal surfaces		N/A
12.3.6	It is clear how the connection and disconnection of the conductors is to be made		N/A
	Disconnection of a conductor require an operation, other than a pull, so that can be made manually with or without a general-purpose tool		N/A
	It is not possible to confuse the opening intended for the use of a tool with the opening intended for the conductor		N/A
12.3.7	Screwless terminals intended for the interconnection of two or more conductors:		N/A
	- the clamping of one of the conductors is independent of the clamping of the other conductor(s)		N/A
	- during the connection or disconnection the conductors can be connected or disconnected either at the same time or separately		N/A
	- each conductor introduced in a separate clamping unit.		N/A
	- it is possible to clamp securely any number of conductors up to the maximum as designed. Number of conductors; Nominal cross-sectional area (mm ²)		N/A
12.3.8	Screwless terminals of fixed socket-outlets: adequate insertion obvious and over-insertion prevented		N/A
12.3.9	Screwless terminals properly fixed to the socket-outlets		N/A
	Not work loose when conductors are connected or disconnected		N/A
	Self-hardening resins used to fix terminals not subject to mechanical stress		N/A
12.3.10	Screwless terminals withstand mechanical stresses occurring in normal use	See appended table 12.3.10	N/A

IEC 60884-1			
Clause	Requirement + Test	Result - Remark	Verdict
	During application of the pull conductor not come out of the terminal		N/A
	Additional test with apparatus shown in figure 11	See appended table 12.3.10	N/A
	During the test: conductors not moved noticeably in the clamping unit		N/A
	After these tests: neither terminals nor clamping means have worked loose and conductors show no deterioration		N/A
12.3.11	Screwless terminals withstand electrical and thermal stresses occurring in normal use	See appended table 12.3.11	N/A
	After the test: inspection show no changes		N/A
	Repetition of mechanical strength test according to 12.3.10	See appended table 12.3.11	N/A
	During application of the pull conductor not come out of the terminal		N/A
	Additional test with apparatus shown in figure 11	See appended table 12.3.11	N/A
	During the test: conductors not moved noticeably in the clamping unit		N/A
	After these tests: neither terminals nor clamping means have worked loose and conductors show no deterioration		N/A
12.3.12	Screwless terminals: connected rigid solid conductor remains clamped, even when deflected during normal installation	See appended table 12.3.12	N/A

13	CONSTRUCTION OF FIXED SOCKET-OUTLETS		
13.1	Socket-contact assembly have sufficient resilience to ensure adequate contact pressure on plug pins		N/A
	Part of socket-contact assembly ensure metallic opposing contacts at least on two sides of each pins		N/A
13.2	Socket-contact and pin(s) of socket-outlet which are made of copper or copper alloy, as specified in 26.5, are considered as complying with this requirement		N/A
	The pin(s) of socket-outlets so constructed in such a way that the mechanical strength of the pin(s) does not depend on the plastic material		N/A
	Compliance is checked by inspection and in case of doubt by the tests of 14.2 and Clause 21 on a new set of specimens without plastic		N/A
13.3	Insulating linings, barriers and the like: adequate mechanical strength		N/A
13.4	Socket-outlets constructed as to permit		N/A

IEC 60884-1			
Clause	Requirement + Test	Result - Remark	Verdict
	- easy introduction into the terminal and reliable connection of the conductors in the terminals, except for lead wires of pilot lights		N/A
	- easy fixing of the main part to a wall or in a mounting box		N/A
	- correct positioning of the conductors		N/A
	- adequate space between the underside of the main part and the surface on which the main part is mounted;		N/A
	- adequate space between the sides of the main part and the enclosure (cover or box);		N/A
	Socket-outlets having screwless terminals, constructed that the connecting and/or disconnecting means of the screwless terminals cannot be activated by the conductors during and after installation		N/A
	Compliance is checked by inspection and in case of doubt by the following test		N/A
	The test is carried out with a solid copper conductor having the smallest cross-sectional area, as specified in 12.3.2. (mm ²).....:		N/A
	If it is not possible to exert a force onto the connecting/disconnecting device, the product is deemed to comply with the requirements without further tests.		N/A
	During the application of the pull, the conductor do not come out of the screwless terminal		N/A
	In addition socket-outlets classified as design A: permit easy positioning and removal of the cover or cover plate, without displacing the conductors or activating the connecting and/or disconnecting means of screwless terminals.		N/A
	Compliance is checked by inspection and by an installation test with conductors of the largest nominal cross-sectional area specified in Table 3 (mm ²).....:		N/A
13.5	Socket-outlets designed that full engagement of associated plugs is not prevented by any projection from their engagement face		N/A
	Gap between the engagement face of the socket-outlet and the plug: not exceed 1 mm		N/A

IEC 60884-1			
Clause	Requirement + Test	Result - Remark	Verdict
13.6	Covers provided with bushings for the entry holes for the pins: not possible to remove them from the outside or for them to become detached inadvertently from the inside when the cover is removed		N/A
13.7	Covers, cover-plates or parts of them intended to ensure protection against electric shock:		N/A
	- held in place at two or more points by effective fixings		N/A
	- fixed by means of a single fixing, for example, by a screw, provided that they are located by another means (for example, by a shoulder)		N/A
	Fixings of covers or cover-plates of socket-outlets of design A serve to fix the main parts: there are means to maintain the base in position, even after removal of the covers or cover-plates		N/A
13.7.1	Covers or cover-plates whose fixings are of the screw-type:		N/A
	Compliance checked by inspection only		N/A
13.7.2	Covers or cover-plates whose fixing is not dependent on screws and whose removal is obtained by applying a force in a direction approximately perpendicular to the mounting/supporting surface:		N/A
	Compliance checked, when their removal may give access, with the standard test finger:		N/A
	to live parts: by the test of 24.14 (verification of the non-removal and the removal)		N/A
	to non-earthed metal parts separated from live parts in such a way that creepage distances and clearances have the values shown in table 23: by the test of 24.15 (verification of the non-removal and the removal)		N/A
	only to parts of insulating material, or earthed metal parts, or metal parts separated from live parts in such a way that creepage distances and clearances have twice the values shown in table 23, or live parts of SEL V circuits not greater than 25 V a.c.: by the test of 24.16 (verification of the non-removal and the removal)		N/A
13.7.3	Covers or cover-plates the fixing of which is not dependent on screws and whose removal is obtained by using a tool, in accordance with the manufacturer's instructions given in an instruction sheet or in other documentation:		N/A
	Compliance checked, when their removal may give access, with the standard test finger:		N/A
	to live parts: by the test of 24.14 (verification of the non-removal only)		N/A

IEC 60884-1			
Clause	Requirement + Test	Result - Remark	Verdict
	to non-earthed metal parts separated from live parts in such a way that creepage distances and clearances have the values shown in table 23: by the test of 24.15 (verification of the non-removal only)		N/A
	only to parts of insulating material, or earthed metal parts, or metal parts separated from live parts in such a way that creepage distances and clearances have twice the values shown in table 23, or live parts of SEL V circuits not greater than 25 V a.c.: by the test of 24.16 (verification of the non-removal only)		N/A
13.8	Cover-plate intended for a socket-outlet with earthing contact: not interchangeable with a cover-plate intended for a socket-outlet without earthing contact		N/A
13.9	Surface-type socket-outlets: no free openings in their enclosures		N/A
13.10	Screws or other means for mounting the socket-outlet on a surface in a box or enclosure: easily accessible from the front		N/A
	Fixing means not serve any other fixing purpose		N/A
13.11	Multiple socket-outlets with a common base: provided with fixed links for the interconnection of the contacts in parallel		N/A
	Fixing of the links independent from the connection of the supply wires		N/A
13.12	Multiple socket-outlets, comprising separate bases: correct position of each base ensured		N/A
	Fixing of each base independent of the fixing of the combination to the mounting surface		N/A
13.13	Mounting plate of surface-type socket-outlets: adequate mechanical strength		N/A
13.14	Socket-outlets withstand the lateral strain imposed by equipment likely to be introduced into them		N/A
	Socket-outlets 16A 250V: test made 4 times with the socket-outlet turned through 90°, 5 N for 1 min (device shown in fig. 13)		N/A
	During the test: device not become disengaged from the socket-outlet		N/A
	After the test:		N/A
	- no damage		N/A
	- socket-outlets comply with clause 22		N/A

IEC 60884-1			
Clause	Requirement + Test	Result - Remark	Verdict
13.15	Socket-outlets are not an integral part of lampholders		N/A
13.16	Surface-type socket-outlets having IP>20 are according to their IP classification when fitted with conduits or with sheathed cables and without a plug in engagement		N/A
	Surface-type socket-outlets having IPX4 and IPX6 have provision for opening a drain hole		N/A
	Socket-outlets with a drain hole: drain hole is not less than 5 mm in diameter, or 20 mm ² in area with a width and a length of not less than 3 mm		N/A
	Drain hole: effective		N/A
	Lid springs (if any): of corrosion-resistant material (bronze or stainless steel)		N/A
13.17	Earthing pins: adequate mechanical strength		N/A
	Not solid pins: compliance checked by inspection and by the test of 14.2 made after the tests of clause 21		N/A
13.18	Earthing contacts, phase contacts and neutral contacts :		N/A
	- locked against rotation;		N/A
	- when the product is ready for the wiring do not possible to be removed without the use of a tool		N/A
13.19	Metal strips of the earthing circuit: no burrs which might damage the insulation of the supply conductors		N/A
13.20	Socket-outlets to be installed in a box: designed that the conductor ends can be prepared after the box is mounted in position, but before the socket-outlet is fitted in the box		N/A
13.21	Inlet openings: allow the introduction of the conduit or the sheath of the cable		N/A
	Surface-type socket-outlets:		N/A
	the conduit or sheath of the cable can enter at least 1 mm into the enclosure		N/A
	inlet opening for conduit entries, or at least two of them if there are more than one, capable of accepting conduit sizes of 16, 20, 25 or 32 according to IEC 60423 or a combination of at least two of any of these sizes		N/A
	inlet opening for cable entries capable of accepting cables having the dimensions specified in table 14 or be as specified by the manufacturer: rated current (A); Limits of external dimensions of cable min/max (mm)		N/A

IEC 60884-1			
Clause	Requirement + Test	Result - Remark	Verdict
13.22	Membranes (grommets) in inlet openings: reliably fixed and not displaced by the mechanical and thermal stresses occurring in normal use		N/A
	Test on membranes subjected to the ageing treatment specified in 16.1 and assembled in the accessories		N/A
	Accessories placed at (40 ± 2) °C for 2 h. Force of 30 N applied for 5 s by test probe 11 of IEC 61032. During the test: no deformation		N/A
	Membranes likely to be subjected to an axial pull: axial pull of 30 N applied for 5 s. During the test: membranes not become detached		N/A
	After the test: no harmful deformation, cracks or similar damage		N/A
	Test repeated with membranes not subjected to any treatment		N/A
13.23	Membranes in inlet openings: introduction of the cables into the accessory permitted when the ambient temperature is low		N/A
	Test on membranes not subjected to the ageing treatment specified in 16.1 and assembled in the accessories		N/A
	Accessories kept at (-15 ± 2) °C for 2 h: possibility to introduce cables of the largest diameter through membranes		N/A
	After the test: no harmful deformation, cracks or similar damage		N/A

14	CONSTRUCTION OF PLUGS AND PORTABLE SOCKET-OUTLETS		
14.1	Non-rewirable portable accessories:		N/A
	flexible cable cannot be separated from the accessory without making it permanently useless		N/A
	Accessory cannot be opened by hand or by using a general purpose tool, for example a screwdriver used as such		N/A
14.2	Pins of portable accessories: adequate mechanical strength	Non-Solid pin	P
	Test for pins not solid (made after clause 21): force of 100 N exerted on the pin, according to figure 14, for 1 min by means of a steel rod \varnothing 4,8 mm		P
	During the application of the force: reduction of the dimension of the pin not exceed 0,15 mm	0,09mm	P
	After removal of the rod: dimensions of the pin not changed by more than 0,06 mm	0,02mm	P
14.3	Pin(s) and contacts of portable accessories:		P

IEC 60884-1			
Clause	Requirement + Test	Result - Remark	Verdict
	- locked against rotation;		P
	- not removable without dismantling the plug;		P
	- adequately fixed in the body of the plug		P
	Earthing or neutral pins or contacts of plugs: not possible to arrange in an incorrect position		P
	The pin(s) of portable accessories constructed in such a way that the mechanical strength of the pin(s) does not depend on the plastic material		P
	Compliance is checked by inspection and in case of doubt by the tests of 14.2 and Clause 21 on a new set of specimens without plastic		P
	Surfaces of plug pin(s) smooth and free from burrs or sharp edges and other irregularities which could cause damage or excessive wear to corresponding socket contacts or shutters		P
14.4	Earthing contacts, phase contacts and neutral contacts of portable socket-outlets:		N/A
	- locked against rotation		N/A
	- removable only with the aid of a tool, after dismantling the socket-outlet		N/A
	In addition, for single portable socket-outlets compliance is checked by the test of 24.2		N/A
14.5	Socket-contact assemblies: sufficient resilience	Earthing connect tube	P
	Parts of socket-contact assemblies:		P
	- are not of insulating material except ceramic, or other material with no less suitable characteristics		P
	- ensure metallic contacts at least on two opposing sides of each pin		P
	Contact pressure of the contact tube does not depend on soldered connection only		P
14.6	Pins and socket-contacts: resistant to corrosion and abrasion		P
	Socket contacts and pin(s) of socket-outlets, which are made of copper or copper alloy, as specified in 26.5, are considered as complying with this requirement.		N/A
14.7	Enclosures of rewirable portable accessories: completely enclose terminals and ends of flexible cable		P
	Construction is unlikely that:		P
	- cores not pressed against each other causing damage		P

IEC 60884-1			
Clause	Requirement + Test	Result - Remark	Verdict
	- cores of live conductor not pressed against accessible metal parts		P
	- core of earthing conductor not pressed against live parts		P
14.8	Rewirable portable accessories: terminal screws or nuts cannot become loose and fall out of position and establish an electrical connection between live parts and earthing terminal or metal parts		P
14.9	Rewirable portable accessories with earthing contact: ample space for slack of earthing (test)		P
	Non-rewirable non-moulded-on accessories with earthing contact: current-carrying conductors stressed before the earthing conductor if the flexible cable slips in its anchorage		N/A
14.10	Terminals of rewirable portable accessories and terminations of non-rewirable portable accessories: located and shielded that loose wires not present a risk of electric shock		P
	Non-rewirable moulded-on portable accessories: provided with means to prevent loose wires of a conductor from reducing the minimum isolation distance requirements		N/A
14.10.1	Rewirable accessories: test with 6 mm free wire		P
	free wire of a conductor connected to a live terminal not touch any accessible metal part or able to emerge from the enclosure		P
	free wire of a conductor connected to an earthing terminal not touch a live part		P
14.10.2	Non-rewirable, non-moulded-on accessories: test with a free wire of length equivalent to the maximum designed stripping length declared by the manufacturer plus 2 mm		N/A
	free wire of a conductor connected to a live termination not touch any accessible metal part or reduce creepage distance and clearance below 1,5 mm to the external surface		N/A
	free wire of a conductor connected to an earth termination not touch any live part		N/A
14.10.3	Non-rewirable, moulded-on accessories:		N/A
	Verification of means to prevent stray wires reducing the minimum distance through insulation to external accessible surface below 1,5 mm		N/A
14.11	Rewirable portable accessories:		P
	- clear how relief from strain and prevention of twisting is intended to be effected		P

IEC 60884-1			
Clause	Requirement + Test	Result - Remark	Verdict
	- cord anchorage, or at least part of it, integral with or securely fixed to one of the component parts of the plug or portable socket-outlet		P
	- makeshift methods not used		P
	- cord anchorage suitable for the different types of flexible cable which may be connected to it; screws, if any: not serve to fix any other component		P
	- cord anchorages: of insulating material or provided with an insulating lining fixed to the metal parts		P
	- metal parts of cord anchorages, including clamping screws: insulated from the earthing circuit		P
14.12	Rewirable portable accessories and non-rewirable non-moulded on portable accessories: it is not possible to remove covers, cover-plates or parts of them intended to ensure protection against electric shock without the use of a tool		P
14.13	Covers of portable socket-outlets: bushings for entry holes for the pins not removable from the outside or detachable inadvertently from the inside		N/A
14.14	Screws intended to allow access to interior of the accessory: captive		P
14.15	Engagement face of plugs: no projections		P
14.16	Engagement face of portable socket-outlets: no projection		N/A
14.17	Portable accessories of IP>20: enclosed according to their IP classification		P
	Plugs having IP>20: adequately enclosed with the exception of the engagement face		P
	Portable socket-outlets having IP>20: adequately enclosed without a plug in engagement		N/A
	Lid springs (if any): of corrosion-resistant material (bronze or stainless steel)		N/A
14.18	Portable socket-outlets: means for suspension from a wall or other mounting surfaces not allow access to live parts		N/A
	No free openings between space intended for suspension means by which the socket-outlet is fixed to the wall, or other mounting surface and live parts		N/A
14.19	Combinations of portable accessories and switches, circuit-breakers or other devices comply with relevant individual IEC standards, if relevant combined product standard does not exist		N/A

IEC 60884-1			
Clause	Requirement + Test	Result - Remark	Verdict
14.20	Portable accessories: not integral part of lampholders		P
14.21	Plugs for equipment of class II:		N/A
	- rewirable or non-rewirable		N/A
	- if part of a cord set: provided with a connector for equipment of class II		N/A
	- if part of a cord extension set: provided with a portable socket-outlet for equipment of class II		N/A
14.22	Components (switches and fuses) incorporated in accessories: comply with the relevant IEC standard as far as it applies		N/A
	Components incorporated in portable accessories so rated, or so protected, that overloading of either the component or the plug or the socket-outlet portion cannot occur in normal use		N/A
	Requirements for switches incorporated in portable accessories are detailed in Annex D	See appended table 14.22	N/A
	For portable socket-outlets and rewirable plugs the incorporated overcurrent protective device in the accessory shall have a rated current equal to or less than the rated current of the accessory		N/A
	Any other component(s), such as switches or control devices, have a rated current not less than (rated current referred to resistive load):		N/A
	- the rated current of the accessory or		N/A
	- the rated current of the incorporated overcurrent protective device, if any		N/A
	For non-rewirable plugs, any other incorporated component(s), such as switches or control devices, have a rated current not less than:		N/A
	- the test current for the combination of the accessory and the cable as indicated in Table 20, for Clause 21, or		N/A
	- the rated current of the incorporated overcurrent protective device, if any		N/A
	Any incorporated component(s) have a rated voltage not less than the rated voltage of the accessory		N/A
	Compliance is checked by inspection and, if necessary, by testing the component according to the relevant IEC standard		N/A
14.23	Plug-in equipment: not cause overheating of the pins or impose undue strain		N/A
	Plugs with rating above 16 A and 250 V: not integral part of other equipment		N/A

IEC 60884-1			
Clause	Requirement + Test	Result - Remark	Verdict
	Tests for two-pole plugs, with or without earthing contact, with rating up to and including 16 A and 250 V (plug of equipment inserted into a fixed socket-outlet complying with this standard):		N/A
14.23.1	Socket-outlet connected to a supply voltage equal to 1,1 times the highest rated voltage of the equipment (V)		—
	Temperature rise of the pins after 1 h not exceed 45 K (K)		N/A
14.23.2	Additional torque applied to the socket-outlet in order to maintain the engagement face in the vertical plane not exceed 0,25 Nm (Nm)		N/A
14.24	Plugs can easily be withdrawn by hand from the relevant socket-outlets		P
	Gripping surfaces are so designed that the plug can be withdrawn without having to pull the flexible cable		P
14.25	Membranes in inlet openings of portable accessories: meet the requirements of 13.22 and 13.23		N/A
14.26	Rewirable portable socket-outlets which can be assembled and wired for normal use after their rear part has been fixed onto a surface comply both with the requirements for portable socket-outlets and with the following additional requirements for surface fixed socket-outlets:		N/A
	- provision for earthing: 11.2, 11.3, 11.6;		N/A
	- terminals and terminations: 12.2.1;		N/A
	- construction of fixed socket-outlets: Clause 13;		N/A
	- resistance to ageing, protection provided by enclosures, and resistance to humidity: 16.2.1, 16.2.2;		N/A
	- temperature rise: Clause 19;		N/A
	- mechanical strength: Clause 24;		N/A
	- resistance to heat: Clause 25;		N/A
	- creepage distances, clearances and distances through sealing compound: Clause 27;		N/A
	- resistance of insulating material to abnormal heat, to fire and to tracking: 28.1.1, glow-wire test		N/A
15	INTERLOCKED SOCKET-OUTLETS		
	Socket-outlet interlocked with a switch:		N/A
	plug cannot be inserted into or completely withdrawn from the socket-outlet while the socket-contacts are live		N/A

IEC 60884-1			
Clause	Requirement + Test	Result - Remark	Verdict
	socket-contacts cannot be made live until a plug is almost completely in engagement		N/A
16	RESISTANCE TO AGEING, PROTECTION PROVIDED BY ENCLOSURES, AND RESISTANCE TO HUMIDITY		
16.1	Resistance to ageing		P
	Accessories are resistant to ageing		P
	For accessories having a lid, the lid is closed during the test		N/A
	Portable socket-outlets: the plug of the same system having the same rated current as the socket-outlet inserted into the socket-outlet during the test		N/A
	Accessories subjected to a test in a heating cabinet at $(70 \pm 2) ^\circ\text{C}$ for seven days (168 h)		P
	After the tests, the specimens show:		P
	- no crack visible with normal or corrected vision without additional magnification		P
	- no sticky or greasy material		P
	- no trace of cloth (forefinger pressed with 5 N)		P
	- no damage		P
	Portable socket-outlets: contact pressure of the contact assembly checked as specified in subclause 22.2 with the single-pin gauge		N/A
16.2	Protection provided by enclosures		P
	Enclosures provide a degree of protection in accordance with the IP designation of the accessory	IP44	P
16.2.1	Protection against access to hazardous parts and against harmful effects due to ingress of solid foreign objects		P
	Accessories and their enclosures provide a degree of protection against access to hazardous parts and against harmful effects due to ingress of solid foreign objects		P
	Fixed socket-outlets: mounted as in normal use on a vertical surface		N/A
	Flush-type and semi-flush type socket-outlets: mounted in an appropriate box according to the manufacturer's instructions		N/A
	Accessories with screwed glands or membranes fitted with flexible cables within the range specified in table 3:		N/A

IEC 60884-1			
Clause	Requirement + Test	Result - Remark	Verdict
	- largest cross-sectional area (mm ²); type of cable (table 17)		—
	- smallest cross-sectional area (mm ²); type of cable (table 17)		—
	Glands tightened with a torque equal to 2/3 of the torque applied during the test of 24.6 (Nm)		—
	Screws of the enclosure tightened with a torque equal to 2/3 of the torque given in table 6 (Nm) ...:		—
16.2.1.1	Protection against access to hazardous parts		P
	Appropriate test performed as specified in IEC 60529 (see also clause 10)	IP44	P
16.2.1.2	Protection against harmful effects due to ingress of solid foreign objects		P
	Appropriate test performed as specified in IEC 60529		P
	Test on accessories with IP5X (considered to be of category 2): dust not penetrated in a quantity to interfere with satisfactory operation or to impair safety		N/A
	Test on accessories with IP6X (considered to be of category 1): dust do not penetrate		N/A
16.2.2	Protection against harmful effects due to ingress of water		P
	Accessories and their enclosures provide a degree of protection against harmful effects due to ingress of water in accordance with their IP classification	IP44	P
	Appropriate test performed as specified in IEC 60529 under the following conditions:		P
	Flush-type and semi-flush type socket-outlets: fixed in a vertical test wall using an appropriate box according to the manufacturer's instructions		N/A
	Accessory suitable to be installed on a rough wall: test wall according to figure 15 is used		N/A
	Surface-type socket-outlets mounted as for normal use in a vertical position and fitted with cables (having conductors of the largest and smallest nominal cross-sectional area given in table 3) or conduits or both in accordance with the manufacturer's instructions:		N/A
	- largest cross-sectional area (mm ²); type of cable (table 17)	N/A	—
	- smallest cross-sectional area (mm ²); type of cable (table 17)	N/A	—
	Portable socket-outlets tested on a plain, horizontal surface in a position as in normal use and fitted with flexible cables (having conductors of the largest and smallest nominal cross-sectional area given in table 3) according to table 17:		N/A

IEC 60884-1			
Clause	Requirement + Test	Result - Remark	Verdict
	- largest cross-sectional area (mm ²); type of cable (table 17)	N/A	—
	- smallest cross-sectional area (mm ²); type of cable (table 17)	N/A	—
	Screws of enclosure tightened with a torque equal to 2/3 of the torque given in table 6 (Nm)	N/A	—
	Glands tightened with a torque equal to 2/3 of the torque applied during the test of 24.6 (Nm)	N/A	—
	Accessory with drain holes opened during the test: any accumulation of water proved by inspection		N/A
	Socket-outlets tested without a plug in engagement		N/A
	Plugs tested when in full engagement with:		N/A
	- a fixed socket-outlets		N/A
	- a portable socket-outlets		N/A
	of the same system and with the same degree of protection against harmful effects due to ingress of water		—
	Specimens withstand an electric strength test specified in 17.2 which is started within 5 min of completion of the IP test		N/A
16.3	Resistance to humidity		P
	Accessories proof against humidity which may occur in normal use		P
	Compliance checked by a humidity treatment carried out in a humidity cabinet containing air with relative humidity maintained between 91 % and 95 %	93%	P
	Specimens kept in the cabinet for:		P
	- two days (48 h) for accessories having IPX0		N/A
	- seven days (168 h) for accessories having IP>X0		P
	After this treatment the specimens show no damage		P

17	INSULATION RESISTANCE AND ELECTRIC STRENGTH		
17.1	Insulation resistance measured 1 min after application of 500 V d.c.	See appended table 17.1	P
17.2	Electric strength: a.c. test voltage applied for 1 min	See appended table 17.2	P

18	OPERATION OF EARTHING CONTACTS		
-----------	---------------------------------------	--	--

IEC 60884-1			
Clause	Requirement + Test	Result - Remark	Verdict
	Earthing contacts provide adequate contact pressure and not deteriorate in normal use		P
	Compliance checked by the tests of clauses 19 and 21		P

19	TEMPERATURE RISE		
	Accessories constructed that they comply with the following temperature rise test		P
	Non-rewirable accessories are tested as delivered		N/A
	In the case of multiple socket-outlets, the test is carried out on one socket-outlet of each type and current rating with the test current as specified in Table 20 passed through that one socket-outlet	See appended tables	N/A
	The temperature rise of the terminals, terminations and clamping units according to Figure 44 determined by means of thermocouples do not exceed 45 K	See appended tables	P
19.1	Socket-outlets and plugs are tested as follows:		P
	Socket-outlets tested using a test plug with brass pins having the minimum specified dimensions	See appended table 19.1	N/A
	For this test the temperature rise is measured on the terminals and terminations.		P
	Plugs tested with clamping units having dimensions specified in Figure 44 fitted on each live pin and earthing pin, if any	See appended table 19.1	N/A
	Plugs having lateral earthing contacts and resilient earthing contacts tested using a fixed socket-outlet complying with the standard and having as near to-average characteristics as can be selected, but with minimum size of the earthing pin, if any	See appended table 19.1	P
19.2	Fixed socket-outlets of a socket-outlet and fused plug system are tested as follows:		N/A
	a) For a single socket-outlet the plug is inserted into the socket-outlet and 70 % of the test current is passed through the plug	See appended table 19.2	N/A
	The balance of the total test current is passed, simultaneously through a looped connection, connected to the socket-outlet terminals		N/A
	The total nominal load on the supply cable is passed for 60 min	See appended table 19.2	N/A
	b) For a multiple socket-outlet a plug is inserted into one socket-outlet and 70 % of the test current is passed	See appended table 19.2	N/A

IEC 60884-1			
Clause	Requirement + Test	Result - Remark	Verdict
	A second plug is inserted into another socket-outlet and the balance of the total test current is passed simultaneously through this plug.....:	See appended table 19.2	N/A
	The total nominal load on the supply cable is passed for 60 min.	See appended table 19.2	N/A
19.3	Portable socket-outlets and rewirable plugs with incorporated components are tested by the following two tests:		N/A
	– with a current which is equal to the test current as indicated in Table 20, for Clause 19	See appended table 19.3	N/A
	– with a current which is equal to the rated current of the portable accessory or the rated current of the component(s), whichever is the lower	See appended table 19.3	N/A
	Non-rewirable plugs with incorporated components are tested by the following two tests:		N/A
	– with a current which is equal to the test current for the combination of the plug and the cable as indicated in Table 20, for Clause 19	See appended table 19.3	N/A
	– with a current which is equal to the test current for the combination of the plug and the cable as indicated in Table 20, for Clause 21, or the rated current of the component(s), whichever is the lower	See appended table 19.3	N/A
20	BREAKING CAPACITY		
	Accessories have adequate breaking capacity		P
	Compliance checked by testing:		P
	- socket-outlets;	See appended table 20	N/A
	- plugs with pins which are not solid	See appended table 20	P
	Multiple socket-outlets: test carried out on one socket-outlet of each type and current rating		N/A
	During the test: no sustained arcing occur		P
	After the test:		P
	- specimens show no damage impairing their further use;		P
	- entry holes for the pins not show any damage which may impair the safety		P
21	NORMAL OPERATION		
	Accessories withstand without excessive wear or other harmful effect, the mechanical, electrical and thermal stresses occurring in normal use		P
	Compliance checked by testing:		P

IEC 60884-1			
Clause	Requirement + Test	Result - Remark	Verdict
	- socket-outlets;	See appended table 21	N/A
	- plugs with resilient earthing socket-contacts;	See appended table 21	P
	- plugs with pins which are not solid	See appended table 21	P
	Test performed according to the procedure specified in Figure 43; point of Figure 43 at which the test program has begun (1, 2, 3)	N/A	—
	Test current passed:		P
	- during each insertion and withdrawal of the plug ($I_n \leq 16A$)		P
	- during alternate insertion and withdrawal, the other insertion and withdrawal being made without current flowing ($I_n > 16A$)		N/A
	Multiple socket-outlets: test carried out on one socket-outlet of each type and current rating		N/A
	During the test: no sustained arcing occur		P
	After the test the specimens do not show:		P
	- wear impairing their further use;		P
	- deterioration of enclosures, insulating lining or barriers;		P
	- damage to the entry holes for the pins, that might impair proper working;		P
	- loosening of electrical or mechanical connections;		P
	- seepage of sealing compound		N/A
	Shuttered socket-outlets: gauges of figure 9 and 10 applied to the entry holes corresponding to live contacts do not touch live parts when they remain under the relevant forces	See appended table 21	N/A
	Temperature-rise test (requirements of clause 19)	See appended table 21	P
	Electric strength (sub-clause 17.2)	See appended table 21	P
	Pins which are not solid: test according to 14.2		P

22	FORCE NECESSARY TO WITHDRAW THE PLUG		
	Construction of accessory does allow the easy insertion and withdrawal of the plug, and prevent the plug from working out of the socket-outlet in normal use		P
22.1	Verification of the maximum withdrawal force	See appended table 22	P
22.2	Verification of the minimum withdrawal force	See appended table 22	P

IEC 60884-1			
Clause	Requirement + Test	Result - Remark	Verdict

23	FLEXIBLE CABLES AND THEIR CONNECTIONS		
23.1	Rewirable plugs and rewirable portable socket-outlets are provided with a cord anchorage		P
	Sheath of flexible cable is clamped within the cord anchorage		P
	In non-rewirable plugs and non-rewirable portable socket-outlets the cable is maintained in position and the terminations are relieved from strain and twisting		N/A
	Sheath of flexible cable is maintained inside the accessory		N/A
23.2	Pull and torque test		P
	Non-rewirable accessories:		N/A
	After the test: displacement ≤ 2 mm	See appended table 23.2	N/A
	No break in the electrical connections		N/A
	Rewirable accessories:		P
	After the test: displacement ≤ 2 mm	See appended table 23.2	P
	End of conductors not have moved noticeably in the terminals		P
	Rewirable accessories having rated current up to and including 16 A:		P
	Suitable for fitting with the appropriate cable as shown in table 19		P
	Type of flexible cable; number of conductors and nominal cross-sectional area (mm ²)	H05RR-F 3x1,5	—
23.3	Non-rewirable plugs and non-rewirable portable socket-outlets are provided with a flexible cable complying with IEC 60227 or IEC 60245		N/A
	Flexible cables have the same number of conductors as there are poles in the plug or socket-outlet		N/A
	Conductor connected to the earthing contact is identified by the colour combination green/yellow		N/A
23.4	Non-rewirable plugs and non-rewirable portable socket-outlets: designed that the flexible cable is protected against excessive bending		N/A
	Guards of insulating material and fixed in reliable manner		N/A
	Flexing test (10.000 flexings)		N/A

IEC 60884-1			
Clause	Requirement + Test	Result - Remark	Verdict
	During the test: no interruption of the test current and no short-circuit between conductors	See appended table 23.4	N/A
	After the test: guard no separated from the body, insulation shows no sign of abrasion or wear, broken strands become no accessible	See appended table 23.4	N/A

24	MECHANICAL STRENGTH		
	Accessories, surface mounting boxes, screwed glands and shrouds have adequate mechanical strength		P
24.1	Fixed socket-outlets, portable multiple socket-outlets and surface-type mounting boxes: hammer test described in IEC 60068-2-75 (test EHA), equivalent mass of 250 g	See appended table 24.4	N/A
	After the test: no damage, live parts no become accessible		N/A
24.2	Portable single socket-outlets and plugs: subjected to test Ec: Rough handling shocks, primarily for equipment-type specimens, procedure 2 of IEC 60068-2-31 (tumbling barrel); number of falls.....: 1000		P
	After the test:		P
	- no part become detached or loosened;		P
	- pins no become so deformed that the plug cannot be introduced into a socket-outlet and also fails to comply with the requirements of 9.1 and 10.3;		P
	- pins no turn when a torque of 0,4 Nm is applied for 1 min in each direction		P
	The shutters of socket-outlets tested again according to Clause 21, from paragraph 19 up to paragraph 24 (only the tests of shutters)		N/A
24.3	Main parts of surface-type socket-outlets: first fixed to a cylinder of rigid steel sheet and then fixed to a flat steel sheet		N/A
	During and after the tests: no damage		N/A
24.4	Portable single socket-outlets, multiple socket-outlets and plugs (elastomeric or thermoplastic material): impact test, weight (1000 ± 2) g, height 100 mm (apparatus shown in fig. 27)		P
	Specimens placed in a freezer at (-15 °C ± 2) °C for at least 16 h. After the test: no damage		P
24.5	Portable single socket-outlets and plugs (elastomeric or thermoplastic material): compression test, 300 N for 1 min, position a) and b) (apparatus shown in fig. 8)		P
	After the test: no damage		P
24.6	Screwed glands of accessories having IP>20: torque test (1 min)		N/A

IEC 60884-1			
Clause	Requirement + Test	Result - Remark	Verdict
	- diameter of test rod (mm)		—
	- type of material (metal / moulded)		—
	- torque (Nm)		—
	After the test: no damage of glands and enclosures of the specimens		N/A
24.7	Plug pins provided with insulating sleeves: 20000 movements, 4 N (apparatus shown in fig. 28)		N/A
	After the test: no damage of pins, insulating sleeve not have punctured or rucked up		N/A
24.8	Shuttered socket-outlets: mechanical test carried out on specimens submitted to the normal operation test according to clause 21		N/A
	Force (40 N / 75 N) applied for 1 min against the shutter of an entry hole by means of one pin (N) .:		—
	Pin did not come in contact with live parts		N/A
	After the test: no damage		N/A
24.9	Mechanical test for multiple portable socket-outlet: 8 falls on concrete floor with the specimens arranged as shown in figure 29		N/A
	Rewirable multiple socket-outlets: flexible cable of the smallest cross-sectional area specified in table 3		—
	After the test: no damage, no part have become detached or loosened		N/A
	Accessories having IP>X0 submitted again to the tests as specified in 16.2		N/A
	The shutters of multiple socket-outlets tested again according to Clause 21, from paragraph 19 up to paragraph 24 (only the tests of shutters)		N/A
24.10	Plugs: pull test to verify the fixation of pins in the body of the plug (new specimens)		P
	Maximum withdrawal force (table 16) applied for 1 min on each pin in turn, after the specimen has been placed at $(70 \pm 2) ^\circ\text{C}$ for 1 h (N)	54N	—
	After the test: displacement of pins in the body of the plug ≤ 1 mm (mm)	Max.0,2mm	P
24.11	Barriers of portable socket-outlets having means for suspension on a mounting surface:		N/A
	Force applied for 10 s against the barrier by means of a cylindrical steel rod (1,5 times the maximum plug withdrawal force in 22.1, table 16) (N)		—
	Rod did not pierce the barrier		N/A
24.12	Portable socket-outlets having means for suspension on a mounting surface (pull test):		N/A

IEC 60884-1			
Clause	Requirement + Test	Result - Remark	Verdict
	Pull applied to the supply flexible cable for 10 s (force prescribed in 23.2 for checking the flexible cable anchorage) (N)		—
	During the test: no break of the means for suspension on a mounting surface		N/A
24.13	Portable socket-outlets having means for suspension on a mounting surface (pull test):		N/A
	Pull applied to the engagement face of the socket-outlet for 10 s (maximum withdrawal force specified, for the corresponding plug, in table 16) (N)		—
	During the test: no break of the means for suspension on a mounting surface		N/A
24.14	Forces necessary to retain or remove covers, cover-plates or parts of them (accessibility with the test finger to live parts)		N/A
24.14.1	Verification of the retention of covers or cover-plates (fixed socket-outlets)		N/A
	Force (40 N / 80 N) applied for 1 min perpendicular to the mounting surface (N)		—
	Covers or cover-plates did not come off		N/A
	Test repeated on new specimens with a sheet of hard material, (1 ± 0,1) mm thick, fitted around the supporting frame (fig. 31): covers or cover-plates did not come off		N/A
	After the test: no damage		N/A
24.14.2	Verification of the removal of covers or cover-plates (fixed socket-outlets)		N/A
	Force not exceeding 120 N applied 10 times perpendicular to the mounting / supporting surface: covers or cover-plates came off		N/A
	Test repeated on new specimens with a sheet of hard material, (1 ± 0,1) mm thick, fitted around the supporting frame (fig. 31): covers or cover-plates came off		N/A
	After the test: no damage		N/A
24.14.3	Verification of the retention of covers or cover-plates (plugs and portable socket-outlets)		N/A
	Force 80 N applied for 1 min perpendicular to the mounting surface: covers, cover-plates or parts of them did not come off		N/A
	Test repeated with a force of 120 N:		N/A
	Rewirable plugs and rewirable portable socket-outlets: covers, cover-plates or parts of them came off but the specimen showed no damage		N/A

IEC 60884-1			
Clause	Requirement + Test	Result - Remark	Verdict
	Non-rewirable, non-moulded-on accessories: covers, cover-plates or parts of them came off but the accessories were permanently useless according to 14.1		N/A
24.15	Force necessary for covers or cover-plates to come off or not to come off (accessibility with the test finger to non-earthed metal parts separated from live parts by creepage distances and clearances according to table 23)		N/A
24.14.1	Verification of the non-removal of covers or cover-plates		N/A
	Force (10 N / 20 N) applied for 1 min in direction perpendicular to the mounting surface (N)		—
	Covers or cover-plates did not come off		N/A
	Test repeated on new specimens with a sheet of hard material, 1 mm ± 0,1 mm thick, fitted around the supporting frame (fig. 31): covers or cover-plates did not come off		N/A
	After the test: no damage		N/A
24.14.2	Verification of the removal of covers or cover-plates		N/A
	Force not exceeding 120 N applied 10 times in direction perpendicular to the mounting / supporting surface: covers or cover-plates came off		N/A
	Test repeated on new specimens with a sheet of hard material, 1 mm ± 0,1 mm thick, fitted around the supporting frame (fig. 31): covers or cover-plates came off		N/A
	After the test: no damage		N/A
24.16	Force necessary for covers or cover-plates to come off or not to come off (accessibility to insulating parts, earthed metal parts, live parts of SELV ≤ 25 V a.c. or metal parts separated from live parts by creepage distances twice those according to table 23)		N/A
24.14.1	Verification of the non-removal of covers or cover-plates		N/A
	Force 10 N applied for 1 min in direction perpendicular to the mounting surface: covers or cover-plates did not come off		N/A
	Test repeated on new specimens with a sheet of hard material, 1 mm ± 0,1 mm thick, fitted around the supporting frame (fig. 31): covers or cover-plates did not come off		N/A
	After the test: no damage		N/A
24.14.2	Verification of the removal of covers or cover-plates		N/A
	Force not exceeding 120 N applied 10 times in direction perpendicular to the mounting / supporting surface: covers or cover-plates came off		N/A

IEC 60884-1			
Clause	Requirement + Test	Result - Remark	Verdict
	Test repeated on new specimens with a sheet of hard material, 1 mm ± 0,1 mm thick, fitted around the supporting frame (fig. 31): covers or cover-plates came off		N/A
	After the test: no damage		N/A
24.17	Test with gauge of figure 7 applied according to figure 9 for verification of the outline of covers or cover-plates: distances between face C of gauge and outline of side under test, not decrease	complying / not complying	—
24.18	Test with gauge according to figure 5 applied as shown in figure 11 (1 N): gauge not enter more than 1mm	complying / not complying	—
24.19	Shroud of portable socket-outlets: compression test (20 ± 2) N at (25 ± 5) °C by means of the apparatus shown in figure 38		N/A
	After 1 min and while the shrouds are still under pressure the dimensions did comply with the appropriate standard sheet		N/A
	Test repeated with the specimen rotated 90 °		N/A

25	RESISTANCE TO HEAT		
25.1	Specimens kept for 1 h in a heating cabinet at (100 ± 2) °C for 1 h		P
	During the test: no change impairing their further use and sealing compound, if any, not flow		P
	After the test:		P
	- no access to live parts with probe B of IEC 61032 applied with a force not exceeding 5 N		P
	- markings still legible		P
25.2	Parts of insulating material necessary to retain current-carrying parts and parts of the earthing circuit in position, as well as parts of the front surface zone, 2 mm wide, surrounding the phase and neutral pin entry holes: ball-pressure test at (125 ± 2)°C for 1 h	See appended table 25.2	P
25.3	Parts of insulating material not necessary to retain current-carrying parts and parts of the earthing circuit in position, even though in contact with them: ball-pressure test (1 h)	See appended table 25.3	N/A
25.4	Portable accessories: compression test (20 N) at (80 ± 2)°C for 1 h by means of the apparatus shown in figure 38		P
	After the test: no damage		P

26	SCREWS, CURRENT-CARRYING PARTS AND CONNECTIONS		
----	--	--	--

IEC 60884-1			
Clause	Requirement + Test	Result - Remark	Verdict
26.1	Connections withstand mechanical stresses		P
	Thread-forming or thread-cutting screws used only if supplied together with the piece in which they are intended to be inserted		N/A
	Thread-cutting screws intended to be used during installation: captive		N/A
	Screws or nuts which transmit contact pressure made of metal and in engagement with a metal thread		N/A
	Threaded part torque test	See appended table 26.1	P
26.2	Screws in engagement with a thread of insulating material: correct introduction into the screw hole or nut ensured		P
26.3	Contact pressure: not transmitted through insulating material other than ceramic, pure mica or other material no less suitable unless there is sufficient resiliency in metallic parts		P
	Connections made by insulation piercing of tinsel cord reliable		N/A
26.4	Screws and rivets locked against loosening and/or turning		P
26.5	Current-carrying parts (including earthing terminals) have mechanical strength, electrical conductivity and resistance to corrosion adequate:		P
	- copper;		N/A
	- alloy with at least 58 % copper for parts made from cold-rolled sheet or with at least 50 % copper for other parts;	>58%	P
	- stainless steel with at least 13 % chromium and not more than 0,09 % carbon		N/A
	- steel with electroplated coating of zinc (ISO 2081): service condition ISO no. (1/2/3); IP (X0/X4/X5); thickness (µm)		N/A
	- steel with electroplated coating of nickel and chromium (ISO 1456): service condition ISO no. (2/3/4); IP (X0/X4/X5); thickness (µm)		N/A
	- steel with electroplated coating of tin (ISO 2093): service condition ISO no. (2/3/4); IP (X0/X4/X5); thickness (µm)		N/A
	Current-carrying parts subjected to mechanical wear: not of steel with electroplated coating		P
	Metals having a great difference of electrochemical potential: not used in contact with each other		N/A

IEC 60884-1			
Clause	Requirement + Test	Result - Remark	Verdict
26.6	Contacts subjected to a sliding action are of metal resistant to corrosion		P
26.7	Thread-forming screws and thread-cutting screws are not used for the connection of current-carrying parts		P
	Thread-forming screws and thread-cutting screws used to provide earthing connection: it is not necessary to disturb the connection and at least two screws are used for each connection		N/A

27	CREEPAGE DISTANCES, CLEARANCES AND DISTANCES THROUGH SEALING COMPOUND		
27.1	Creepage distances, clearances and distances through sealing compound are not less than the values shown in table 23	See appended table 27.1	P
27.2	Insulating sealing compound does not protrude above the edge of the cavity in which it is contained		N/A
27.3	Surface-type socket-outlets do not have bare current-carrying strips at the back		N/A

28	RESISTANCE OF INSULATING MATERIAL TO ABNORMAL HEAT, TO FIRE AND TO TRACKING		
28.1	Resistance to abnormal heat and to fire		P
28.1.1	Glow-wire test according to IEC 60695-2-10 and IEC 60695-2-11	See appended table 28.1.1	P
28.1.2	Plugs with pins provided with insulating sleeves:		N/A
	Test temperature maintained for 3 h by means of the apparatus shown in figure 40 at $(120 \pm 5) ^\circ\text{C}$ / $(180 \pm 5) ^\circ\text{C}$		—
	Impact test according to sub-clause 30.4 (mass 100 g, height 100 mm, 4 impacts): no cracks of the insulating sleeves		N/A
28.2	Resistance to tracking		P
	Parts of insulating material retaining live parts in position of accessories having IP>X0: of material resistant to tracking		P
	Tracking test at 175 V with solution A of IEC 60112	See appended table 28.2	P

29	RESISTANCE TO RUSTING		
	Ferrous parts protected against rusting		P

IEC 60884-1			
Clause	Requirement + Test	Result - Remark	Verdict
	Test made after having removed all grease using a suitable degreasing agent: 10 min 10 % solution of ammonium chloride, 10 min in a box with air saturated with moisture and 10 min at (100 ± 5) °C:		P
	No signs of rust		P
30	ADDITIONAL TESTS ON PINS PROVIDED WITH INSULATING SLEEVES		
30.1	Pressure test at high temperature		N/A
	Apparatus shown in figure 41, with the test specimen in position, maintained for 2 h at (200 ± 5) °C. Force applied through the blade: 2,5 N		N/A
	Thickness of the insulation measured: before the test (mm); after the test (mm)		—
	Thickness remaining at the point of impression is not reduced by more than 50 % of its original value measured at the start of the test: percentage value (%)		N/A
30.2	Static damp heat test		N/A
	Set of 3 specimens submitted to two damp heat cycles in accordance with IEC 60068-2-30 (variant 2 with a temperature of 40 °C).		N/A
	After the test:		N/A
	- insulation resistance and electric strength test (clause 17)		N/A
	- abrasion test (sub-clause 24.7)		N/A
30.3	Test at low temperature		N/A
	Set of 3 specimens maintained at (-15 °C ± 2) °C for 24 h		N/A
	After the test:		N/A
	- insulation resistance and electric strength test (clause 17)		N/A
	- abrasion test (sub-clause 24.7)		N/A
30.4	Impact test at low temperature		N/A
	Specimens maintained at (-15 °C ± 2) °C for 24 h subjected to 4 impacts (mass 100 g, height 100 mm) by means of the apparatus shown in figure 42 rotating the specimen through 90 ° between impacts		N/A
	After the test: no crack of the insulating sleeves		N/A

IEC 60884-1			
Clause	Requirement + Test	Result - Remark	Verdict

12.2.5	TABLE: test with apparatus shown in figure 11 (screw-type terminals)			P
	rated current (A)	:		—
	type of conductors	:	rigid solid / rigid stranded / flexible	—
	smallest/largest cross-sectional area per table 3 (mm ²)	:	0,75 / 1,5	—
	number of conductors	:	1	—
	nominal diameter of thread (mm); torque per table 6 (Nm)	:	2,84mm; 0,5Nm	—
Cross-sectional area (mm ²)	Diameter of bushing hole per table 9 (mm)	Height H per table 9 (mm)	Mass (kg)	Remarks
0,75	6,5	260	0,4	P
1,5	6.5	260	0,4	P
supplementary information:				

12.2.6	TABLE: pull test (screw-type terminals)			P
	rated current (A)	:	16A	—
	smallest/largest cross-sectional area per table 3 (mm ²)	:	0,75 / 1,5	—
	nominal diameter of thread (mm); torque 2/3 per table 6 (Nm)	:	2,84mm; 0,33Nm	—
Cross-sectional area (mm ²)	Number of conductors	Type of conductors (rigid solid / rigid stranded / flexible)	Pull per table 4 applied for 1 min (N)	Remarks
0,75	1	Flexible	40	P
1,5	1	Flexible	40	P
supplementary information:				

IEC 60884-1			
Clause	Requirement + Test	Result - Remark	Verdict

12.2.7	TABLE: tightening test (screw-type terminals)			P
	rated current (A)	16A		—
	nominal diameter of thread (mm); torque 2/3 per table 6 (Nm)	2,84mm; 0,33Nm		—
Largest cross-sectional area per table 3 (mm ²)	Permissible number of conductors ⁽¹⁾	Type of conductors (rigid solid / rigid stranded / flexible)	Number of wires and nominal diameter of wires per table 5	Remarks
1,5	1	Flexible	30 x 0,25	P
supplementary information: ⁽¹⁾ terminals intended for looping-in 2 or 3 conductors				

12.3.10	TABLE: mechanical strength test (screwless-type terminals)			N/A	
	rated current (A)			—	
	largest/smallest cross-sectional area per table 7 (mm ²)			—	
Number of connection (after that conductor subjected to a pull of 30 N for 1 min) / disconnection	Type of conductor (solid / rigid stranded / flexible)	Cross-sectional area (mm ²)	Remarks		
TABLE: test with apparatus shown in figure 11					
Cross-sectional area (mm ²)	Type of conductor (solid / rigid stranded / flexible)	Diameter of bushing hole per table 9 (mm)	Height H per table 9 (mm)	Mass (kg)	Remarks
supplementary information:					

12.3.11	TABLE: electrical and thermal strength test (screwless-type terminals)			N/A
Test a)	Test carried out for 1 h connecting rigid solid conductors:			N/A
	test current per table 10 (A)			—
	nominal cross-sectional area (mm ²)			—
Screwless terminal number	Voltage drop (mV)		Required voltage drop (mV)	
1			≤ 15	
2			≤ 15	

IEC 60884-1						
Clause	Requirement + Test				Result - Remark	Verdict
3					≤ 15	
4					≤ 15	
5					≤ 15	
Test b)	Temperature cycles test carried out on terminals subjected to Test a):					N/A
	test current per table 10 (A)					—
	nominal cross-sectional area (mm ²)					—
	allowed voltage drop (mV)				≤ 22,5 mV or 2 times 24 th cycle value (mV)	—
Screwless terminal number	1	2	3	4	5	Remarks
voltage drop after 24 th cycle						
voltage drop after 48 th cycle						
voltage drop after 72 nd cycle						
voltage drop after 96 th cycle						
voltage drop after 120 th cycle						
voltage drop after 144 th cycle						
voltage drop after 168 th cycle						
voltage drop after 192 nd cycle						
12.3.10	TABLE: mechanical strength test (screwless-type terminals)					N/A
	rated current (A)					—
	largest/smallest cross-sectional area per table 7 (mm ²)					—
Number of connection (after that conductor subjected to a pull of 30 N for 1 min) / disconnection		Type of conductor (solid / rigid stranded / flexible)		Cross-sectional area (mm ²)		Remarks
TABLE: test with apparatus shown in figure 11						N/A
Cross-sectional area (mm ²)	Type of conductor (solid / rigid stranded / flexible)	Diameter of bushing hole per table 9 (mm)	Height H per table 9 (mm)	Mass (kg)	Remarks	
supplementary information:						
12.3.12	TABLE: deflection test (principle of test apparatus shown in figure 12a)					N/A

IEC 60884-1							
Clause	Requirement + Test			Result - Remark			Verdict
	Test carried out connecting rigid solid copper conductors:						N/A
	test current (A) (equal rated current)						—
	required voltage drop (mV)			≤ 25 mV			—
Type of conductor	Smallest			Largest			Remarks
cross-sectional area per table 11 (mm ²)							
force per table 12 (N)							
screwless terminal number	1	2	3	1	2	3	
starting point (X = deflection original point)	X	X+10°	X+20°	X	X+10°	X+20°	
voltage drop 1 st deflection (mV)							
voltage drop 2 nd deflection (mV)							
voltage drop 3 rd deflection (mV)							
voltage drop 4 th deflection (mV)							
voltage drop 5 th deflection (mV)							
voltage drop 6 th deflection (mV)							
voltage drop 7 th deflection (mV)							
voltage drop 8 th deflection (mV)							
voltage drop 9 th deflection (mV)							
voltage drop 10 th deflection (mV)							
voltage drop 11 th deflection (mV)							
voltage drop 12 th deflection (mV)							
supplementary information:							

14.22	TABLE: Components					N/A
Object / part No.	Manufacturer/ trademark	Type / model	Technical data	Standard	Mark(s) of conformity ¹⁾	
Supplementary information: ¹⁾ Provided evidence ensures the agreed level of compliance. See OD-CB2039.						

17.1	TABLE: insulation resistance			P
Item per 17.1	test voltage applied between:	measured (MΩ)	required (MΩ)	
a	between all poles connected together and the body, the measurement being made with a plug in engagement;	199	≥5	

IEC 60884-1			
Clause	Requirement + Test	Result - Remark	Verdict
b	between each pole in turn and all others, these being connected to the body with a plug in engagement;	199	≥5
d	Between any metal part of the cord anchorage , including clamping screws, and earthing terminals or earthing contacts	199	≥5
e	Between any metal part of the cord anchorage and a metal rod of the maximum diameter of the flexible cable inserted in its place	199	≥5
supplementary information:			

17.2	TABLE: electric strength			P
	rated voltage (V)	250V~		—
item per 17.1	test voltage applied between:	test voltage (V)	flashover / breakdown (Yes/No)	
a	between all poles connected together and the body, the measurement being made with a plug in engagement;	2000	No	
b	between each pole in turn and all others, these being connected to the body with a plug in engagement;	2000	No	
d	Between any metal part of the cord anchorage , including clamping screws, and earthing terminals or earthing contacts	2000	No	
e	Between any metal part of the cord anchorage and a metal rod of the maximum diameter of the flexible cable inserted in its place	2000	No	
supplementary information:				

19.1	TABLE: temperature rise test for socket-outlets and plugs							P
	rated current of accessory (A)		16A					—
	type of accessory (non-rewirable / rewirable)		rewirable					—
	nominal cross-sectional area per table 15 (mm ²) :		1,5					—
	type of conductors (rigid solid / rigid stranded / flexible)		Flexible					—
	nominal diameter of thread (mm); torque 2/3 of that specified in 12.2.8 (Nm		2,84mm; 0,33Nm					—
specimen	type of flexible cable ⁽¹⁾	number of conductors and nominal cross-sectional area (mm ²) ⁽¹⁾	test circuit (L-L/L-N/L-E)	test current (table 20) for 1 h (A)	measured ΔT (K)	allowed ΔT (K)	ΔT of external parts of insulating material (25.3) (K)	
	H05VV-F	3x1,5mm ²	L-N/L-E	20	Max.25	45	Max.5	
supplementary information:								
⁽¹⁾ Non-rewirable accessories								

IEC 60884-1									
Clause	Requirement + Test							Result - Remark	Verdict
19.2	TABLE: temperature rise test for fixed socket-outlets of a socket-outlet and fused plug system								N/A
	rated current of accessory (A)								—
	type of accessory (non-rewirable / rewirable)								—
	nominal cross-sectional area per table 15 (mm ²) :								—
	type of conductors (rigid solid / rigid stranded / flexible)								—
	nominal diameter of thread (mm); torque 2/3 of that specified in 12.2.8 (Nm								—
	Test a) single socket-outlet								N/A
specimen	type of flexible cable (1)	number of conductors and nominal cross-sectional area (mm ²) (1)	test circuit (L-L/L-N/L-E)	70% of test current (table 20) for 1 h (socket-outlet) (A)	30% of test current (table 20) for 1 h (looped) (A)	test current (table 20) for 1 h (supply cable) (A)	measured ΔT (K)	allowed ΔT (K)	ΔT of external parts of insulating material (25.3)(K)
supplementary information: (1) Non-rewirable accessories									
	Test b) multiple socket-outlet								N/A
specimen	type of flexible cable (1)	number of conductors and nominal cross-sectional area (mm ²) (1)	test circuit (L-L/L-N/L-E)	70% of test current (table 20) for 1 h (1 st socket-outlet) (A)	30% of test current (table 20) for 1 h (2 nd socket) (A)	test current (table 20) for 1 h (supply cable) (A)	measured ΔT (K)	allowed ΔT (K)	ΔT of external parts of insulating material (25.3)(K)
supplementary information: (1) Non-rewirable accessories									
19.3	TABLE: temperature rise test for plugs and portable socket-outlets with incorporated components								N/A
	rated current of accessory (A)								—
	type of accessory (non-rewirable / rewirable)								—
	nominal cross-sectional area per table 15 (mm ²) :								—
	type of conductors (rigid solid / rigid stranded / flexible).....								—

IEC 60884-1								
Clause	Requirement + Test					Result - Remark	Verdict	
	nominal diameter of thread (mm); torque 2/3 of that specified in 12.2.8 (Nm :)						—	
	Test for Portable socket-outlets and rewirable plugs with incorporated components							N/A
specimen	type of flexible cable ⁽¹⁾	number of conductors and nominal cross-sectional area (mm ²) ⁽¹⁾	test circuit (L-L/L-N/L-E)	Test current (table 20), Clause 19 for 1 h (components short circuited) (A)	Test current is rated current of the portable accessory or the rated current of the component (s), whichever is the lower (A)	measured ΔT (K)	allowed ΔT (K)	ΔT of external parts (25.3)(K) ⁽²⁾
supplementary information: (1) Non-rewirable accessories ; (2) Metal parts 30 K ; non-metallic parts 40 K								
	Test for non-rewirable plugs with incorporated components							N/A
specimen	type of flexible cable (1)	number of conductors and nominal cross-sectional area (mm ²) (1)	test circuit (L-L/L-N/L-E)	Test current is equal to the test current for the combination of the plug and the cable as indicated in Table 20, for Clause 19. (components short circuited) (A)	Test current is equal to the test current for the combination of the plug and the cable as indicated in Table 20, for Clause 21 or the rated current of the component (s), whichever is the lower (A)	measured ΔT (K)	allowed ΔT (K)	ΔT of external parts (25.3)(K) ⁽²⁾
supplementary information: (1) Non-rewirable accessories; (2) Metal parts 30 K ; non-metallic parts 40 K								

20	TABLE: breaking capacity					P
	rating of accessory (A/V)	16A/ 250V			—	
	type of accessory (non-rewirable / rewirable)	rewirable			—	
	type of flexible cable (non-rewirable accessories)	N/A			—	
	number of conductors and nominal cross-sectional area (mm ²) (non-rewirable accessories)	N/A			—	
	nominal cross-sectional area per table 15 (mm ²) :	1,5mm ²			—	
	type of conductors (rigid solid / rigid stranded / flexible).....	Flexible			—	

IEC 60884-1										
Clause	Requirement + Test						Result - Remark		Verdict	
	nominal diameter of thread (mm); torque 2/3 of that specified in 12.2.8 (Nm)..... :						2,84mm; 0,33Nm		—	
	rate of operation (strokes per minute)						30		—	
specimen	test plug (for each type and current rating of socket-outlet)		test voltage (1,1 Vn) (V)	test current (1,25 In) cos φ 0,6 (A)	number of strokes (plugs only)	number of strokes, with shutters – with current ⁽¹⁾	number of strokes, without shutters – with current ⁽²⁾	remarks		
	pin dimensions (mm)	pin spacing (mm)								
-	-	-	275V	20A	100	-	-	-	P	
supplementary information: ⁽¹⁾ starting point 1 or 3 of Figure 43 ⁽²⁾ starting point 2 of Figure 43										

21	TABLE: normal operation								P
	rating of accessory (A/V)						16A/250V~		—
	type of accessory (non-rewirable / rewirable) :						rewirable		—
	type of flexible cable (non-rewirable accessories)						N/A		—
	number of conductors and nominal cross-sectional area (mm ²) (non-rewirable accessories)						N/A		—
	nominal cross-sectional area per table 15 (mm ²) :						1,5mm ²		—
	type of conductors (rigid solid / rigid stranded / flexible)..... :						Flexible		—
	nominal diameter of thread (mm); torque 2/3 of that specified in 12.2.8 (Nm)..... :						2,84mm; 0,33Nm		—
	rate of operation (strokes per minute)						30		—
specimen	test plug (for each type and current rating of socket-outlet)		test voltage (Vn) (V)	test current (table 20), cos φ 0,8 (A)	number of strokes (plugs only)	number of strokes, with shutters – with current ⁽¹⁾	number of strokes, without shutters – with current ⁽²⁾	number of strokes, with shutters – without current ⁽³⁾	
	pin dimensions (mm)	pin spacing (mm)							
-	-	-	-	-	10000	-	-	-	P
	TABLE: test for shuttered socket-outlets								N/A
specimen	Gauge of figure 9, applied with a force of 20 N, for approximately 5 s, successively in three directions				Steel gauge of figure 10, applied with a force of 1 N for approximately 5 s, in three directions				

IEC 60884-1					
Clause	Requirement + Test			Result - Remark	Verdict
19	TABLE: temperature rise test				P
specimen	test circuit (L-L/L-N/L-E)	test current (table 20 for clause 21) for 1 h (A)	measured dT (K)	allowed dT (K)	
-	L-L/L-N/L-E	16A	Max.25	≤45	P
17.2	TABLE: electric strength				P
specimen	item per 17.1	test voltage applied between:	test voltage (V)	flashover / breakdown (Yes/No)	
-	a)	all poles connected together and the body	2000	No	
-	b)	each pole in turn and all others, these being connected to the body	2000	No	
-	d)	any metal part of the cord anchorage and earthing terminal or earthing contact	2000	No	
-	e)	any metal part of the cord anchorage and a metal rod of the maximum diameter	2000	No	
supplementary information:					
⁽¹⁾ starting point 1 or 3 of Figure 43					
⁽²⁾ starting point 2 of Figure 43					
⁽³⁾ starting point 1 or 2 of Figure 43					
22	TABLE: force necessary to withdraw the plug				P
	Rated current (A)		16A		—
	Number of poles		2P+E		—
22.1	Verification of the maximum withdrawal force				P
specimen	socket-outlets (multi-pin gauge)		plugs with resilient earthing contact assemblies (single-pin gauge)		
	maximum withdrawal force (N)	the test plug did not remain in the socket- outlet (Y/N)	maximum withdrawal force (N)	the test pin gauge did not remain in the contact assembly	
-	-	-	18	N(not remain)	P
22.2	Verification of the minimum withdrawal force				P
specimen	socket-outlets (single-pin gauge)		plugs with resilient earthing contact assemblies (single-pin gauge)		

IEC 60884-1					
Clause	Requirement + Test			Result - Remark	Verdict
	minimum withdrawal force (N)	the test pin gauge did not fall from each individual contact-assembly within 30 s (Y/N)	minimum withdrawal force (N)	the test pin gauge did not fall from each individual earthing contact-assembly within 30 s (Y/N)	
-	-	-	2	N(not fall)	P
supplementary information:					

23.2	TABLE: pull and torque test					P
	rating of accessory (A)		16A 250V~			—
	type of accessory (non-rewirable / rewirable)		rewirable			—
	smallest/largest cross-sectional area per table 17 (mm ²) (rewirable accessories)		0,75 / 1,5			—
	nominal diameter of thread (mm); torque 2/3 per table 6 (Nm) (rewirable accessories)		2,84mm; 0,33Nm			—
specimen	type of flexible cable	number of conductors and nominal cross-sectional area (mm ²)	pull (100 times) (N)	torque (1 min) as specified in table 18 (Nm)	displacement (mm)	
	H05VV-F	3x0,75	60	0,25	MAX.1,2mm	P
	H05VV-F	3x1,5	60	0,25	MAX.1,3mm	P
supplementary information:						

23.4	TABLE: flexing test					N/A
	rated current (A)					—
specimen	type of flexible cable	number of conductors and nominal cross-sectional area (mm ²)	test current (A)	mass (N)		

supplementary information:					
TABLE: impact test					N/A
part of enclosure tested per table 21 (A, B, C, D)	blows per part	height of fall (mm)	comments		

25.2	TABLE: ball pressure test of insulating materials				P
	allowed impression diameter (mm)		≤ 2 mm		—
part under test	test temperature (°C)		impression diameter (mm)		

IEC 60884-1			
Clause	Requirement + Test	Result - Remark	Verdict

Insert	125	Max.1,7mm	
supplementary information:			

25.3	TABLE: ball pressure test of insulating materials		N/A
	allowed impression diameter (mm)	≤ 2 mm	—
part under test	test temperature (°C) ⁽¹⁾	impression diameter (mm)	
supplementary information: ⁽¹⁾ (70 ± 2) °C / (40 ± 2) °C + highest temperature rise determined during the test of clause 19			

26.1	TABLE: threaded part torque test					P
threaded part identification	diameter of thread (mm)	column number (1, 2 or 3)	applied torque (Nm)	times (5/10)	no damage	
Terminal screws	2,84	2	0,5	5	P	
Cord anchorage screws	2,84	2	0,5	10	P	
Assembly screws	2,85	2	0,5	10	P	
supplementary information:						

27.1	TABLE: creepage distances, clearances and distances through sealing compound							P
	rated voltage (V)	250V~					—	
item per table 23	creepage distance dcr, clearance cl and distance through sealing compound dtsc at/of:	require d cl (mm)	cl (mm)	require d dcr (mm)	dcr (mm)	require d dtsc (mm)	dtsc (mm)	
1), 6)	between live parts of different polarity	≥ 3	>4 (by gauge)	≥ 3	>4 (by gauge)	≥	-	
2), 7)	between live parts and accessible surface of parts of insulating material	≥ 3	>4 (by gauge)	≥ 3	>4 (by gauge)	≥	-	
2); 7)	between live parts and parts of earthing circuit	≥ 3	> 4 (by gauge)	≥ 3	> 4 (by gauge)	≥	-	
2); 7)	-external assembly screws, other than screws which are on the engagement face of plugs and are isolated from the earthing circuit	≥ 3	> 4 (by gauge)	≥ 3	> 4 (by gauge)	≥	-	
supplementary information:								

28.1.1	TABLE: glow-wire test	P
---------------	------------------------------	---

IEC 60884-1					
Clause	Requirement + Test			Result - Remark	Verdict
part under test	material designation	test temperature (°C)	visible flame and sustained glowing (Y/N)	flame and glowing extinction time	ignition of the tissue paper (Y/N)
Insert	PP	750	N	-	N
Enclosure	TPR	650	N	-	N
supplementary information:					

28.2	TABLE: resistance to tracking				P
	number of drops	:	50		—
part under test	material designation		test voltage (V)	flashover / breakdown (Yes/No)	
Insert	PP		175	No	
supplementary information:					

Annex A: Additional requirements and test according to CEE 7

Additional requirements and test according to standard CEE 7 / VII
 The clause No in brackets refers to standard sheet CEE 7 / VII

<p>9 (8a)</p>	<p>DIMENSIONS Compliance with appropriate Standard Sheet checked by means of gauges and by measurement, see below</p>	<p>P</p>
<p>The technical drawing shows a circular electrical plug with the following dimensions and tolerances:</p> <ul style="list-style-type: none"> Outer diameter: $\phi 36.5 \pm 0.51$ Distance between contact centers: 19 ± 0.2 (C10) Contact diameter: $\phi 4.8 \pm 0.06$ Contact length: 3.5 ± 0.3 Distance from top edge to contact center: 10 ± 0.1 Distance from bottom edge to contact center: 32 ± 0.5 Distance between contact tips: 32 ± 0.5 Minimum distance from contact tip to bottom edge: 3 MIN Minimum distance from contact tip to side edge: 6 MIN Minimum distance from contact tip to top edge: 15.5 MIN Minimum distance from contact tip to bottom edge: 19 ± 0.5 Minimum distance from contact tip to side edge: 17.5 MIN Minimum distance from contact tip to bottom edge: 14.5 MIN Minimum distance from contact tip to bottom edge: 16.5 MIN Minimum distance from contact tip to bottom edge: 20 ± 0.5 Minimum distance from contact tip to bottom edge: 1 ± 0.1 Minimum distance from contact tip to bottom edge: 0 ± 0.5 Maximum angle: 90 MAX Maximum diameter of contact tip: $\phi 2.5 \text{ MAX}$ Maximum distance from contact tip to bottom edge: 3 MAX 		

Clause	Gauges and Figures CEE7	Test of / Test	Verdict
9.1 (8a)	C1	Socket-outlets / <i>Size of the entry holes for the plug pin.</i>	N/A
	C2A	Socket-outlets / <i>Minimum opening of contact tubes.</i>	N/A
	C2B	Plugs / <i>Minimum opening of earthing contact tubes.</i>	P
	C3	Socket-outlets / <i>Acceptance of two pole plugs.</i>	N/A
	C4	Socket- outlets with side earthing contacts / <i>Acceptance of two pole plugs with side earthing contacts.</i>	N/A
	C6	Fixed socket outlet of surface type. If applicable	N/A
	C7	Socket-outlets / <i>Distance to point of first contact</i>	N/A
	C9	Plugs and for socket outlets with pin type earthing contact / <i>Pin diameter</i>	P
	C10	Plugs / <i>Pin space.</i>	P
	C11	Socket-outlets and plugs with pin type earthing contact / <i>Max. opening of contact tubes</i>	P
	C12	Plug with side earthing contacts / <i>Interchangeability</i>	P
	Fig.13	2,5A plugs according to Standard sheet XVI / <i>Interchangeability</i>	N/A
9.2 (8b)	Fig. 15	2p plugs without earthing contacts / <i>non- interchangeability with two-pole plugs with earthing contact</i>	N/A
	Fig. 16	2p socket-outlets with side earthing contacts/ <i>non-acceptance of two-pole plugs without earthing contact</i>	N/A
10.3 (9b)	Fig. 18	16 A socket-outlets / <i>impossibility of single-pole insertion of plugs</i>	N/A
	Fig. 19	Plugs / <i>Checking impossibility of single pole insertion</i>	P
10.6 (9d)	Fig. 19a	Checking deformation of side earthing contact for socket outlets / <i>150N 1min</i>	N/A
13.4 (8a)	C8	Fixed socket outlet of surface type. / <i>Wiring channel if applicable</i>	N/A
18 (18)	Socket outlets with side earthing. Measuring the force exerted by the earthing contacts by means of the device CEE7/Figure 23		
	Test by measuring the force exerted by the earthing contacts (min 5N)		N/A
	After the tests of 19, 20 and 21 the contacts are separated to the maximum distance possible, max 35 mm for 48 h. After this treatment, the socket outlet is subjected to the test of Temperature Rise		
	The force exerted measured in side earthing contacts. Not less than 60% or 5 N		N/A
	For other accessories, compliance is checked by the tests of Temperature Rise and Normal Operation		

Annex B:

Additional requirements and test according to standard sheet VIIb of SS 4280834:2013+ R1:2017 + T1:2018

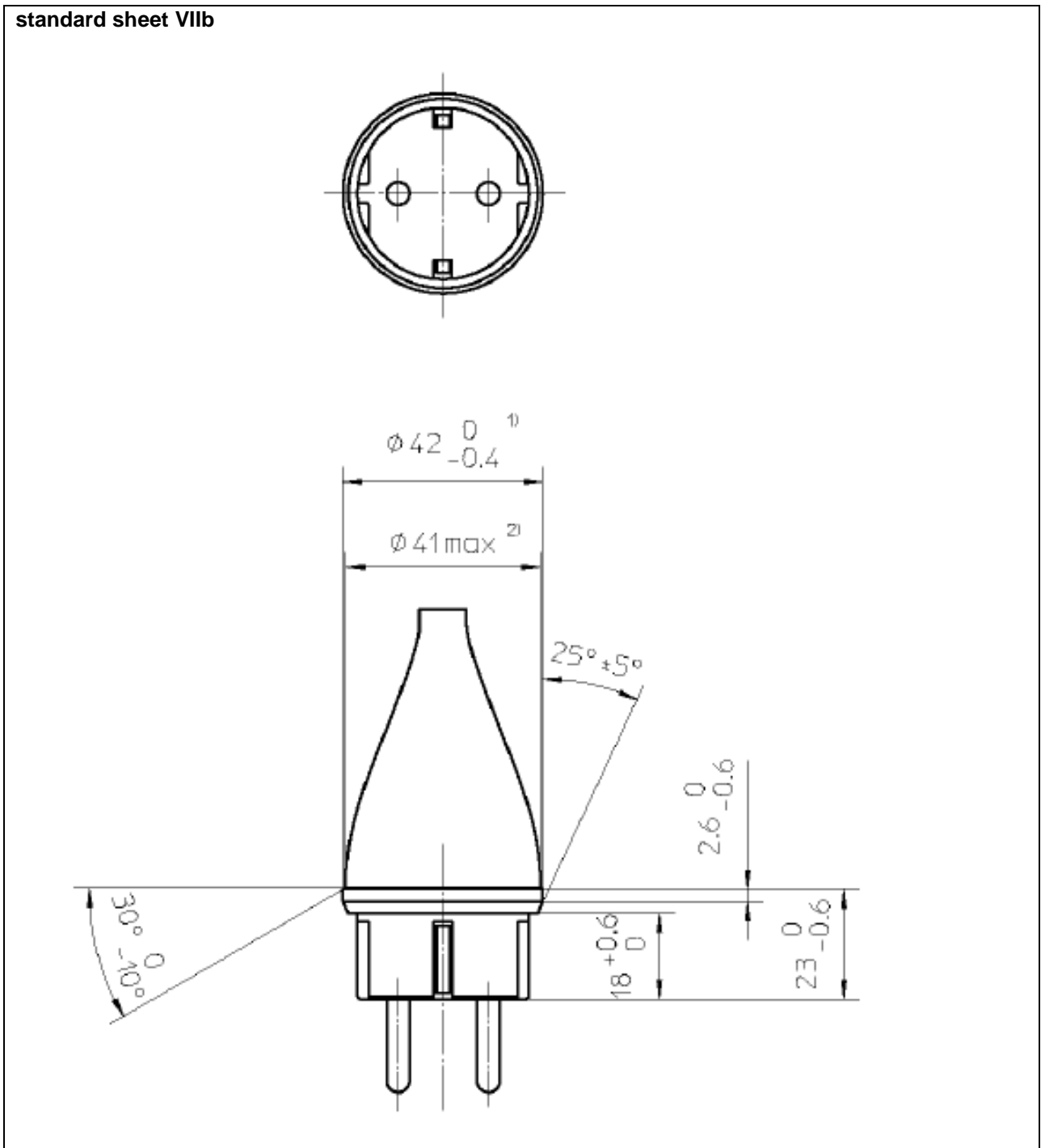

Annex C: Nordic ed3 (FI, NO, and SE)

Additional requirements and tests for plugs and socket-outlets according Nordic agreement.

Following national standards are considered.

~~Finland: SFS 5610:2015 + A11:2016~~

~~Norway: NEK 502:2016~~

Sweden: SS 4280834:2013 + R1:2017 + T1:2018

Tests according to IEC 61884-1:2002+A1:2006+A2:2013 and CEE 7 (Annex CEE/7) with below Nordic additions to IEC 60884-1:2002+A1:2006+A2:2013 and CEE 7

7.2.3 NO	Rail-mounting		N/A
7.2.4 SE/NO/FI	Design B is not used		N/A
7.3 FI	Plugs for class 0 equipment are allowed		N/A
8	The rated current for class II socket-outlets (2,5A/250V) for fixed installation shall be marked 16A/2,5A.		N/A
8.1 NO	6 th dash: replace "higher than 4" with "4 or higher" 7 th dash: replace "higher than 2" with "4 or higher"		N/A
8.7 NO	Indication of which position or with which special provisions the declared IP degree of flush-type and semi-flush-type fixed socket-outlets having IP >X0 is ensured.		N/A
8.101 SE/FI	Socket-outlets and plugs according to standard sheets VIII and IX, the poles (terminals) shall be marked with L ₁ , L ₂ , L ₃ and N and be positioned as indicated in the standard sheets.		
	- socket-outlet is allowed to be installed only into a box including the PE-conductor		N/A
	- there shall be at least one class I socket-outlet in that room where class II socket-outlet (2,5A/250V) is to be installed.		N/A
8.102	Socket-outlets and plugs according to standard sheets VIII and IX, the poles (terminals) shall be marked with L, N and PE and be positioned as indicated in the standard sheets.		N/A
9.1	Standardsheets if applicable	Standardsheet:	CEE 7 / VII
	Add standard sheet if different from Annex CEE 7		standard sheet VIIb of SS 4280834
9.1	Socket outlets for 16A 250V.		
	C2A (400G) FI	Socket-outlets / <i>Minimum opening of contact tubes.</i>	N/A
	C2A (2N) SE, NO	Socket-outlets / <i>Minimum opening of contact tubes.</i>	N/A
9.1 SE/NO/FI	Socket outlets for 2,5A 250V. SS 428 08 34/ X and Xa , SFS5610/ XVIA , NEK 502/XVIA Test with gauges		
	C1/C1A	Socket-outlets / <i>Size of the entry holes for the plug pin</i>	N/A
	C2/C2A	Socket-outlets / <i>Minimum opening of contact tubes.</i>	N/A
	C3/C3A	Socket-outlets / <i>Acceptance of two pole plugs.</i>	N/A
	C4/C7A	Socket-outlets / <i>Distance to point of first contact</i>	N/A
9.101 SE/NO	Standard sheet IIIa	Socket-outlets / <i>impossible to insert a plug (A pin with a diameter of 3,85 ± 0,05 mm) according to EN 50075 to a socket outlet (sheet III a.)</i>	
	Test with 75N, 1min. Ambient temperature 35°C		N/A

National deviation			
Clause	Requirement + Test	Result - Remark	Verdict

Annex C: Nordic ed3 (FI, NO, and SE)

Additional requirements and tests for plugs and socket-outlets according Nordic agreement.

9.102 NO	For 25A 250V 2P+E plugs and socket-outlets compliance with Standard Sheets X and XI			
	- are checked by measurements only			N/A
9.102 SE	For 25A 250V 2P+E plugs and socket-outlets compliance with Standard Sheets VIII and IX			
	- are checked by measurements only			N/A
10.1 SE/ NO / FI	Socket outlets for 2,5A 250V. Single pole insertion gauge fig 6			
	- not possible to touch live part trough the space intended for suspension means			N/A
10.2 SE	Fixed socket-outlets with covers or cover plates of metal,			
	- requirements given in 10.2.1 or 10.2.2 are full-filled			N/A
	Portable socket-outlets and plugs with accessible parts of metal,			
	- the requirements given in 10.2.1 are full-filled			N/A
10.2.2 SE/ FI / NO	This subclause is applicable only for fixed socket outlets			N/A
10.3 SE/ NO / FI	SS 428 08 34 / SE18 / 18a	2,5A / 16A socket-outlets / impossibility of single-pole insertion of plugs.		N/A
10.5 NO	Shutters are mandatory according to national wiring rules for all areas where children can be present.			N/A
12.1.101	Socket-outlets for appliance shall be provided with		<input type="checkbox"/> screw-type terminals, <input type="checkbox"/> screwless terminals, <input type="checkbox"/> male tab of flat quick-connect terminations <input type="checkbox"/> soldered connections <input type="checkbox"/> welded connections (terminations).	N/A
12.2.1 Table. 3	Current and type of the accessory	Rigid (solid or stranded) copper conductors	Flexible copper conductor	
		Cross-sectional area mm ²	Cross-sectional area mm ²	
	16 A 2P + ⊕ (fixed accessory)	From 1,5 up to 2 x 2,5 inclusive (Ø 2,2 mm HD 383)		N/A
	16 A 2P + ⊕ (fixed accessory)		From 1,5 up to 2 x 2,5 inclusive if applicable (Ø 2,2 mm HD 383)	N/A
SE	16 A 2P + ⊕ (portable socket-outlets)		From 1 up to 1,5 inclusive (Ø 1,8 mm HD 383)	N/A
SE	16 A 2P + ⊕ (plugs)		From 0,75 up to 1,5 inclusive (Ø 1,8 mm HD 383)	P
SE	2.5 A 2P Socket-outlets integrated in appliances or equipment	From 0.5 up to 1.0 inclusive (Ø 1,4 mm HD 383)	From 0.5 up to 1 inclusive (Ø 1,5 mm HD 383)	N/A
SE	2.5 A 2P Portable socket-outlets		From 0.5 up to 1 inclusive (Ø 1,5 mm HD 383)	N/A
SE	25A 2P + (portable accessory)		From 2,5 up to 6 inclusive (Ø 3,05 mm)	N/A
NO	25A (fixed accessories)	From 4 up to 6 inclusive (Ø 3,3 mm HD 383)		N/A
NO	25A (plugs)		From 2.5 up to 4 inclusive (Ø 3,2 mm HD 383)	N/A

National deviation			
Clause	Requirement + Test	Result - Remark	Verdict

Annex C: Nordic ed3 (FI, NO, and SE)

Additional requirements and tests for plugs and socket-outlets according Nordic agreement.

12.2.6 SE/FI/NO	For fixed socket-outlets an additional test with one rigid solid conductor and one rigid stranded conductor with the same cross-sectional area connected at the same time is required for terminals allowing the connection of two conductors.		N/A
12.2.7 FI	For fixed socket-outlets an additional test with one rigid solid conductor and one rigid stranded conductor with the same cross-sectional area connected at the same time is required for terminals allowing the connection of two conductors.		N/A
13.1 SE/NO	Parts of socket-contact assemblies, which will be in contact with the portion of the pin intended to make electrical contact when the plug is fully inserted in the socket-outlet:		
	- shall not be of insulating material, except ceramic, or other material with no less suitable characteristics, and		N/A
	- shall ensure metallic opposing contacts at least on two sides of each pin		N/A
13.4 FI	Design B is not accepted in fixed installation due to installation practice.		N/A
13.8 SE	For socket-outlets according to standard sheet VIII,		
	- it must not be possible to mount the cover or cover plate in the wrong position e.g. turned 180°		N/A
13.8.101 SE	It shall not be possible to fix the cover or cover plate of class I socket-outlet to class II socket-outlet of the same manufacturer.		N/A
13.9	Socket outlets for surface mounting with degree of protections of IP 20 or higher		
NO/FI/SE	- shall be provided with a protective plate to provide insulation against the mounting surface		N/A
13.10 NO	Claw fixing is not permitted		N/A
13.10 FI	Claw fixing is allowed in special cases provided that suitable boxes are used.		N/A
13.14 SE	Socket-outlets with rating up to and including 16 A and 250 V shall withstand lateral strain imposed by equipment likely to be introduced into them.		
	Compliance is checked by means of the device shown in Fig. 13		N/A
	Test performed with 15 N.		N/A
13.14 NO	Replace "Figure 13" with "Figure NO 21"		N/A
13.20 NO	After all the conductors are terminated the socket outlet shall fit easily into the gauge according to Figure NO 24a		N/A
13.23	Test is performed at -15°C		N/A
14.21 NO/SE	Plugs for class II equipments shall be non-rewirable		N/A
14.21 FI	Rewirable cord set is allowed,		
	- except cord set exclusively intended for the connection of an electrical appliances of class II to the electrical supply		N/A
14.22 NO	Requirements for the components except switches incorporated in portable socket-outlets are given in Annex NO-3.		N/A

National deviation			
Clause	Requirement + Test	Result - Remark	Verdict

Annex C: Nordic ed3 (FI, NO, and SE)

Additional requirements and tests for plugs and socket-outlets according Nordic agreement.

14.101	For plugs according to standard sheet IX,			
	- the pins shall be floating (self-adjusting)			N/A
14.102	For plugs according to standard sheet IX, with side cable entry hole,			
	- the cable entry hole shall be affixed to the side of the connector body, opposite the (7 mm wide) tab			N/A
17.1 SE	Add: The insulation resistance between live parts and SELV-circuits shall not be less than 7 MΩ.			N/A
17.2 SE	Add to second paragraph: - 3750 V between live parts and SELV-circuits.			N/A
18.1 SE/NO/FI	Socket outlets with side earthing.			
	Measuring the force exerted by the earthing contacts by means of the device CEE7/Figure 23.			N/A
	Test by measuring the force exerted by the earthing contacts (min 5N)			N/A
	After the tests of 19, 20 and 21 the contacts are separated to the maximum distance possible, max 35 mm for 48 h.			N/A
	After this treatment, the socket outlet is subjected to the test of Temperature Rise.			N/A
	The force exerted measured in side earthing contacts. Not less than 60% or 5 N			N/A
	For other accessories, compliance is checked by the tests of Temperature Rise and Normal Operation			N/A
18.2 SE/NO	Plugs with side earthing contacts. Test equipment according to Fig. 25 (SS 428 08 34)			
	Contact pressure of side earthing contacts in a plug, 168h with 50 N at 35°C, max deformation 1 mm	Measured:	MAX.0,2mm	P
19 SE/NO	Temperature rise test for non rewirable portable socket outlets. The test current for 1,0 and 1,5 mm ² shall be 16A for socket outlets with rated current 16A and 4A for socket outlet with rated current 2,5A.			
	Cross section of the cable:		mm ²	
	Rated current:	A	Test current:	A
	Rated current:	A	Test current:	A
19 NO	Additional temperature rise 14 days (336h) test for fixed socket outlets with screwless terminals. • Three new specimens are used. • The specimens are connected in series by interconnecting conductors and shall not passed through the socket outlets.			
	<input type="checkbox"/> surface mounted	Rigid solid conductors:	mm ²	N/A
	<input type="checkbox"/> flush mounted	Rigid stranded conductors:	mm ²	N/A
	Test current	1,125 x rated current:	A	N/A
	Temperature rise	Measured after 14 days (max 45 K):	K	N/A
20 SE/NO	Breaking capacity for 2,5A socket outlets 50 times with 3A / 275VAC cos φ= 0.6			N/A

National deviation			
Clause	Requirement + Test	Result - Remark	Verdict

Annex C: Nordic ed3 (FI, NO, and SE)

Additional requirements and tests for plugs and socket-outlets according Nordic agreement.

21 SE/ NO	Normal operation test for non rewirable portable socket outlets The test current for 1,0 and 1,5 mm ² shall be 16A for socket outlets with rated current 16A and 2,5A for socket outlet with rated current 2,5A			
	Cross section of the cable:		mm ²	
	Rated current:	A	Test current:	A
	Rated current:	A	Test current:	A
22.1	Maximum withdrawal force for 16 A socket outlets. Gauge SE 26 (SS 428 08 34) / NA24 (SFS5610) / NO26 (NEK502)			N/A
	Maximum withdrawal force for 2,5 A socket outlets. Gauge SE 26 (SS 428 08 34) / NO27 (NEK502)			N/A
22.2 SE/ FI	Minimum force for 16 A and 2,5A socket outlets. (Pin diameter: 3.8±0,05, Mass: 200 g)			
	Gauge Fig SE2/C2A (SS 428 08 34) / NA2/C2A (SFS5610)			N/A
22.2 NO	Minimum force for 16 A and 2,5A socket outlets. (Pin diameter: 3.8±0,05, Mass: 200 g) For portable multiple socket outlets and adaptors the rails are removed from the socket outlets.			
	Gauge NO2/C2A.			N/A
23 SE	See Table 17 – External dimensions of flexible cables to be accommodated by cord anchorages.			P
	See Table 20 – Relationship between rating of accessories, nominal cross-sectional areas of test conductors and test currents for the tests of temperature rise (Clause 19) and normal operation (Clause 21).			P
	In addition, for rewirable accessories having a rated current up to and including 25 A, it shall be checked by a manual test that they are suitable for fitting with the appropriate cable, as shown in table 19.			N/A
23.3 SE/ NO	For none rewirable portable socket outlets with rating above 10A up to and incl 16A a cross sectional area of 1,0 mm ² are only allowed in flexible lengths up to 2 m. Table 20.			
	Cable length: < 2m; Cross sectional area:		mm ²	
24.101 SE	Blows applied with a spring hammer to all accessible surfaces			N/A
26.7 FI	Thread cutting screws are not allowed as screws that are operated during installation.			N/A
27 SE	Socket-outlets for appliances are tested with the metal frame, if any, placed in the most unfavourable positions if this frame, acting as a support, is movable.			N/A
	For fixed socket outlets of flush type the box according to CEE7 / Standard sheet XIII is used when measured the distances.			N/A
	Clearances and creepage distances between live parts of different polarity			
	- are reduced to 1 mm between the lead wires in the pinch of an indicator lamp with external resistor			N/A
	For socket outlets the max. ring diameter 8 mm of the pin of the plug according to 10.4 is considered.			N/A
28 SE	For the purpose of this test, socket-outlets for appliances are tested as fixed socket-outlets.			N/A

National deviation			
Clause	Requirement + Test	Result - Remark	Verdict

Annex C: Nordic ed3 (FI, NO, and SE)

Additional requirements and tests for plugs and socket-outlets according Nordic agreement.

SE/NO	Switches incorporated in portable socket outlets (additions in Annex D of SS 4280834:2013 + R1:2017 + T1:2018 and NEK 502:2016)		
SE	Stand-by switches shall be marked "stand-by" or with the symbol 		N/A
	Table D1 Minimum switch ratings:		
	Resistive & motorload	A	N/A
	Inductive load	A	N/A
	Capactive load	A	N/A

SE/ FI	Cord extension sets (additions in Annex NB of SS 4280834:2013 + R1:2017 + T1:2018 & SFS 5993:2012)		
SE	Cord extension sets shall comply with SS-IEC 60884-2-7 (IEC 60884-2-7:2011+ A1:2013)		N/A
FI	Cord extension sets shall comply with IEC 60884-2:2011		N/A
8 SE	Cord extension sets exclusively for use in industrial application, construction sites or other locations where children are not present		
	- shall be accompanied by an information of the limited area of use		N/A
10.2 SE	Cord extension sets shall be so designed and constructed that after they are wired and assembled as for normal use, live parts are not accessible, even after removal of parts which can be removed without the use of a tool		N/A
	Compliance is checked by inspection and by applying with a test wire of 1,0 mm diameter (see Figure 10 of Part 1) a force of 1 N in every possible position		N/A
	During this test, it shall not be possible to touch live parts with the gauge		N/A
14.1 SE	Socket-outlets in cord extension sets for general use shall have shutters		N/A
	Flexible cables shall comply with the SS-EN 50525-series		N/A
14.1 FI	Socket-outlets to be used in cord extension sets shall have shutters.		N/A
14.1 FI	If the enclosure of a cord extension set are at least IPX4, there is no need shutter.		N/A
	Plugs and sockets shall be designed in accordance with standard sheet SFS 5610 Annex NA.		N/A
14.2 FI	The conductors must be at least 1.0mm ² for class 0 and II cord extension set, and the conductors must be at least 1.5mm ² for class I cord extension sets.		N/A
14.21 SE	Cord extension sets exclusively for class II equipment shall be non-rewirable.		N/A

Photos:



Overall view



Side view

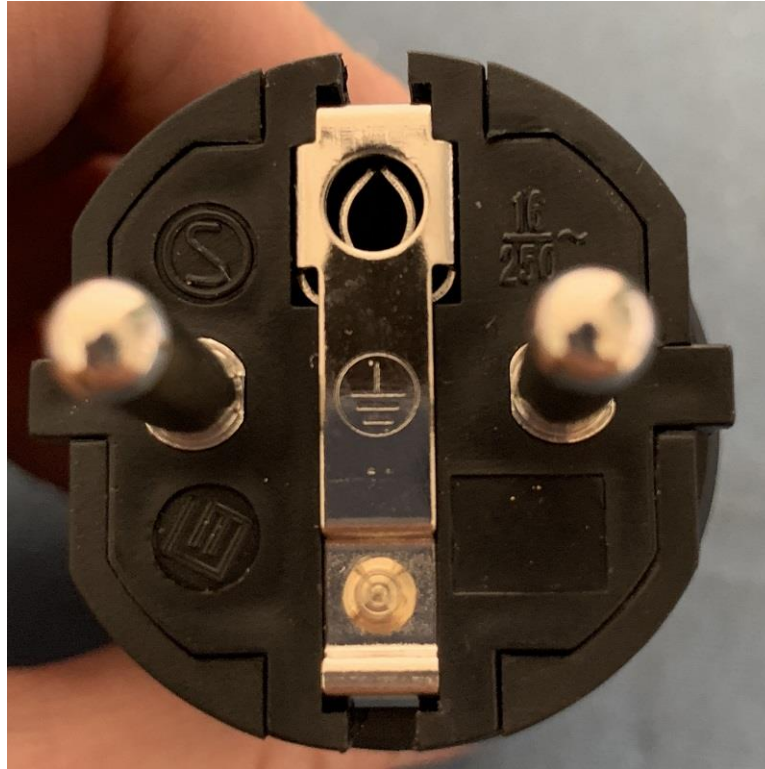

Engagement view



Internal view

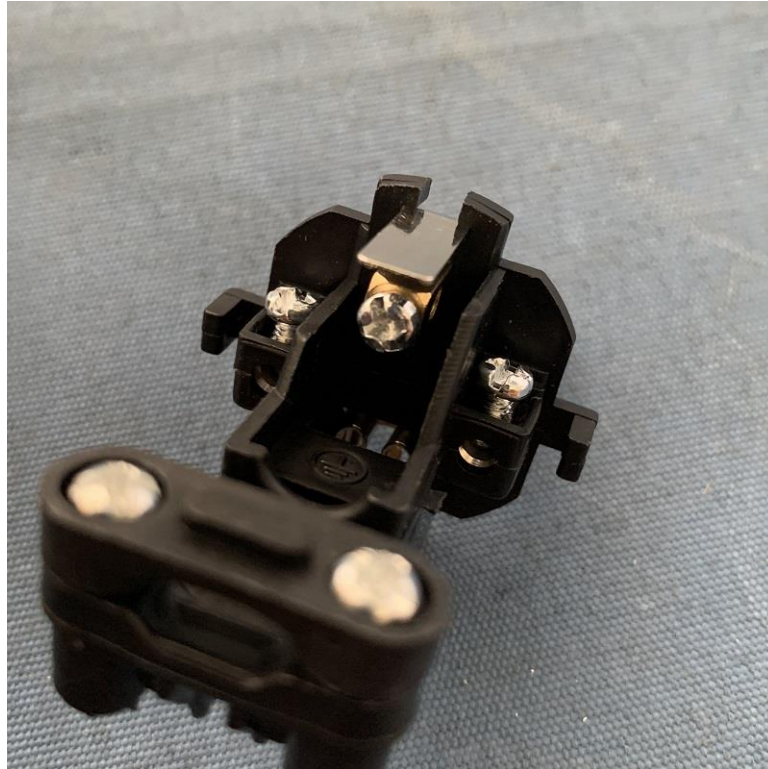

Screw-type of terminal view



Internal view



Cord entry hole