

# PBD250

1000V level DC to DC solar charge controller, used together with ATESS PCS and Bypass for large scale solar projects.

## Features

-  Multiple units parallelable
-  Modular design
-  Up to 5 MPPTs
-  Transformerless design



## Block Diagram

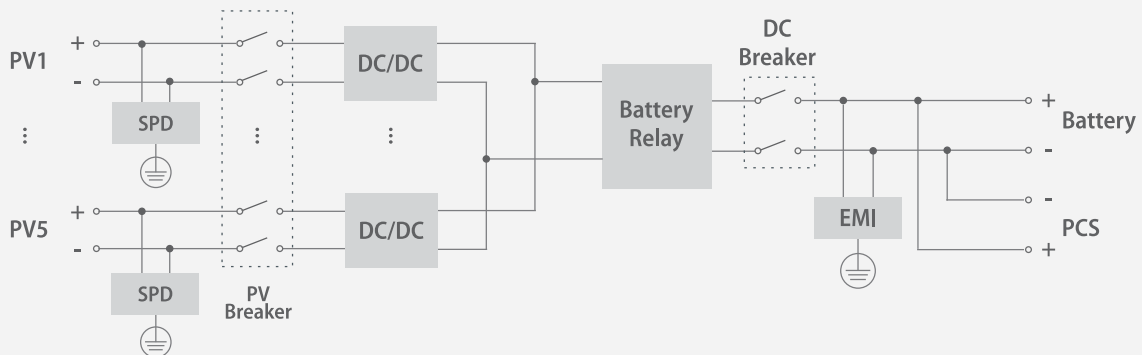

## PBD250

### Input (PV)

Max. PV power	250kW
MPPT voltage range	350V-850V
Full load MPPT voltage range	480V-850V
Max. input current	575A(115A*5)
Number of MPPT	5

---

### Output (Battery and PCS)

Output voltage	600V-900V
Max. charge power	250kW
Max. charge current	416A
Max. charge efficiency	99%

---

### Protection

Input & output OV/UV protection	Yes
Input & output OC protection	Yes
Short circuit protection	Yes
Over temperature protection	Yes
Lightning protection	Type II
DC breaker	Yes
Emergency stop	Yes

---

### General Information

Protection degree	IP20
Noise emission	<65dB(A)@1m
Operating temperature	-25 °C~+55 °C
Cooling method	Forced-air
Relative humidity	0-95% non-condensing
Max. altitude	6000m (derate over 3000m)
Dimension (W/H/D)	800/1900/650mm
Weight	289kg
Topology	Transformerless
Standby power	<100W

---

### Communication

Display	Touch screen
Communication	RS485/CAN

---