



The Global Language of Business

# Scan4Transport Pilot Report

*Release 1.1, Published, November 2021*



## Document Summary

Document Item	Current Value
Document Name	Scan4Transport Pilot Report
Document Date	November 2021
Document Version	1.1
Document Status	Published

## Contributors

Name	Company	Role
Alexiou Koumaras	Leopard Systems	Solution Provider
Agata Witkowska	GS1 Poland	Standards Organisation
Anthony Tanner	VT Freight Express	Logistic Service Provider
Ben Woodward	SmartFreight	Solution Provider
Bonnie Ryan	GS1 Australia	Standards Organisation
Chris Liesenkoetter	DHL New Zealand	Logistic Service Provider
Dan Mullen	GS1 Global Office	Standards Organisation
David Greening	VT Freight Express	Logistic Service Provider
David Pollard	New Zealand Post	Logistic Service Provider
Ed Jesus	Chep	Shipper
Eugen Sehorz	GS1 Austria	Standards Organisation
Gary Hartley	GS1 New Zealand	Standards Organisation
Gavin Looi	DHL Supply Chain	Logistic Service Provider
Heide Buhl	GS1 Germany	Standards Organisation
Jaco Voorspuij	GS1 Global Office	Standards Organisation
James Best	Australia Postal Corporation	Logistic Service Provider
Jeanne Duckett	Avery Dennison	Solution Provider
Jeff Shillington	Avery Dennison	Solution Provider
Jennifer Gordon	GS1 Global Office	Standards Organisation
Jeroen Van Weperen	GS1 Australia	Standards Organisation
John Butera	SICK	Solution Provider
John Ryu	GS1 Global Office	Standards Organisation

Name	Company	Role
Karl Brooks	DHL Supply Chain Australia	Logistic Service Provider
Mark Chaston	Border Express	Logistic Service Provider
Mark Harrison	GS1 Global Office	Standards Organisation
Matthew Mahoney	New Zealand Post	Logistic Service Provider
Michael Toolan	SmartFreight	Solution Provider
Michiel Ruighaver	GS1 Australia	Standards Organisation
Nuno Bento	MIXMOVE	Solution Provider
Odarci Roque de Maia Junior	Correios (Brazil Post)	Logistic Service Provider
Sandra Wagner	GS1 Germany	Standards Organisation
Simon Waugh	DHL Supply Chain New Zealand	Logistic Service Provider
Thierry Grumiaux	GS1 France	Standards Organisation

## Log of Changes

Release	Date of Change	Changed By	Summary of Change
1.0	Sep 2021	Michiel Ruighaver	Posted for S4T MSWG Review 27 Sep – 15 Oct
1.1	November 2021	Michiel Ruighaver	Minor changes following Work Group review

## Disclaimer

GS1®, under its IP Policy, seeks to avoid uncertainty regarding intellectual property claims by requiring the participants in the Work Group that developed this **Scan4Transport Pilot Report GS1 Document Type** to agree to grant to GS1 members a royalty-free licence or a RAND licence to Necessary Claims, as that term is defined in the GS1 IP Policy. Furthermore, attention is drawn to the possibility that an implementation of one or more features of this Specification may be the subject of a patent or other intellectual property right that does not involve a Necessary Claim. Any such patent or other intellectual property right is not subject to the licencing obligations of GS1. Moreover, the agreement to grant licences provided under the GS1 IP Policy does not include IP rights and any claims of third parties who were not participants in the Work Group.

Accordingly, GS1 recommends that any organisation developing an implementation designed to be in conformance with this Specification should determine whether there are any patents that may encompass a specific implementation that the organisation is developing in compliance with the Specification and whether a licence under a patent or other intellectual property right is needed. Such a determination of a need for licencing should be made in view of the details of the specific system designed by the organisation in consultation with their own patent counsel.

THIS DOCUMENT IS PROVIDED "AS IS" WITH NO WARRANTIES WHATSOEVER, INCLUDING ANY WARRANTY OF MERCHANTABILITY, NONINFRINGEMENT, FITNESS FOR PARTICULAR PURPOSE, OR ANY WARRANTY OTHERWISE ARISING OUT OF THIS SPECIFICATION. GS1 disclaims all liability for any damages arising from use or misuse of this document, whether special, indirect, consequential, or compensatory damages, and including liability for infringement of any intellectual property rights, relating to use of information in or reliance upon this document.

GS1 retains the right to make changes to this document at any time, without notice. GS1 makes no warranty for the use of this document and assumes no responsibility for any errors which may appear in the document, nor does it make a commitment to update the information contained herein.

GS1 and the GS1 logo are registered trademarks of GS1 AISBL.

# Table of Contents

<b>1</b>	<b>Executive Summary .....</b>	<b>6</b>
<b>2</b>	<b>Background .....</b>	<b>7</b>
2.1	Transport Industry Challenges .....	7
<b>3</b>	<b>About Scan4Transport Standards .....</b>	<b>9</b>
3.1	Scan4Transport Benefits .....	9
3.1.1	Interoperability.....	9
3.1.2	Efficiency .....	10
3.1.3	Resilience .....	10
3.1.4	Visibility .....	10
3.1.5	Agility .....	11
<b>4</b>	<b>GS1 keys and AIs used in Scan4Transport solution .....</b>	<b>12</b>
4.1	Expressing data using GS1 Application Identifiers.....	12
4.2	GS1 keys and AIs used in Scan4Transport solution.....	12
4.3	Ship-to AIs used in Scan4Transport solution.....	13
4.4	Return-to AIs used in Transport solution .....	13
4.5	Handling AIs used in Scan4Transport solution.....	13
4.6	Handling of percent encoding in programming. ....	14
<b>5</b>	<b>Scan4Transport Pilot .....</b>	<b>15</b>
5.1	Concatenated GS1 Element String Approach.....	15
5.2	GS1 Digital Link URI AI Approach.....	15
5.3	Scan4Transport 2D Symbologies.....	16
<b>6</b>	<b>Using GS1 Digital Link based approach.....</b>	<b>18</b>
6.1	GS1 Digital Link data .....	18
6.2	Recommended data carriers .....	18
6.3	Example GS1 Digital Link URI with S4T data in URI query string .....	18
6.4	Example XML translation .....	19
6.5	Example JSON translation .....	19
6.6	Example JSON-LD translation and RDF Turtle .....	20
6.7	Example HTML Table .....	21
6.8	Example S4T Logistic Label (GS1 Digital Link approach).....	21
6.9	Recommendations for constructing a GS1 Digital Link URI.....	22
<b>7</b>	<b>Sample Labels.....</b>	<b>24</b>
7.1	Concatenated AI label.....	24
7.2	GS1 Digital Link label .....	24
<b>8</b>	<b>Scan4Transport Pilots.....</b>	<b>25</b>
8.1	Pilot scope.....	25
8.2	Pilot participants .....	25
8.3	Pilot Streams .....	25
8.3.1	Desktop Pilot.....	25
8.3.2	Lab/Small Pilot .....	26

8.3.3	Physical/full pilot .....	26
8.4	Test Cases .....	26
8.5	Learnings .....	28
<b>9</b>	<b>Quotes from Industry .....</b>	<b>30</b>
<b>10</b>	<b>Deployment kit .....</b>	<b>32</b>
<b>11</b>	<b>Recommendations .....</b>	<b>33</b>
11.1	Promote S4T standards and pilot results within industry .....	33
11.2	Develop Deployment Kit including promotional assets for MO's and industry .....	33
11.3	Migration plan.....	33
11.4	Encourage additional companies/individuals to participate in Scan4Transport Work Group/User Group and/or T&L Centre of Excellence .....	33
11.5	Recruit additional pilots and encourage industry adoption .....	33
11.6	Profile implementations.....	33
11.7	Promote compliant solutions .....	33
11.8	Submit S4T standards for additional Industry Awards .....	34
11.9	Grow and maintain the Scan4Transport website ( <a href="http://www.gs1.org/industries/transport-and-logistics/scan4transport">www.gs1.org/industries/transport-and-logistics/scan4transport</a> ) .....	34
11.10	Track industry awareness (e.g. # downloads of S4T implementation guideline) .....	34
<b>12</b>	<b>Feedback &amp; Questions .....</b>	<b>35</b>
<b>13</b>	<b>Appendix .....</b>	<b>36</b>
13.1	Typographical conventions used in this document .....	36
13.2	References .....	36

# 1 Executive Summary

This report is a deliverable from the global Scan4Transport pilots run in early 2021 involving major companies from Europe, the United States, Australia and New Zealand. It provides an overview of the standards piloted along with the learnings and recommendations from the Scan4Transport Global Working Group for consideration by industry. The pilots aimed to validate the new standards meet industry requirements and supported improvements in efficiency, interoperability, connectivity and visibility across the Freight & Logistics process. The pilots also included forward looking GS1 Digital Link URI syntax methods and were used to refine the [Scan4Transport implementation guideline](#).

The freight transport industry is fragmented with 40,000 Logistic Service Providers in Australia alone and millions around the world to support the delivery of different types of freight (e.g. bulk, satchels, parcels, pallets, ugly freight, etc), to different locations (e.g. metro, regional, interstate, international), via different service levels (e.g. standard, overnight, same day express, etc). Most of the businesses across the supply chain use different systems, each with their own proprietary standard ("language") for encoding data into barcodes on the Transport Label and sharing information (e.g. transport instructions and status notifications). Subsequently, connecting the different systems ("learning and translating the different languages") and automating the processes to capture data across supply chains is not always cost effective. This causes manual processes, duplicated effort, cost and freight visibility delays/gaps for companies across the supply chain as freight is often handled by multiple logistic service providers in the journey from A to B.

To simplify communication between people and ensure our messages are not lost in translation, we define and speak a common language within the society we live. Similarly, to effectively digitise, it is time for shippers and logistic service providers across the supply chain to agree on which 'language' computer systems are going to use to exchange information across the supply chain.

The new Scan4Transport standards developed and piloted are a "global language" for encoding the minimum data required by parties into a 2D barcode to support the supply chain and enable the freight transport process. This information includes:

- A globally unique freight unit identifier (Serial Shipping Container Code – SSCC),
- Ship-to information (e.g. company, contact, address, phone number, etc),
- Handling information (e.g. routing codes, service descriptions, authority to leave the freight at the delivery point if no one is available to receipt the goods, etc) and
- Return-to information (e.g. company, contact, address, phone number, etc).

As the Scan4Transport standards are technology agnostic, they can be incorporated into existing systems across the supply chain to enable everyone to "talk a common language." This makes it easier and more cost effective for businesses to adopt technology and connect with each other.

## 2 Background

Following feedback from Shippers and Logistic Service Providers seeking a more standardised approach to encode key transport information in a 2D barcode on the logistics label, GS1 Australia initiated a Work Request in 2018 to have GS1 Supply Chain Standards developed.





The Scan4Transport global working group was subsequently established in January 2019, chaired by Michiel Ruighaver from GS1 Australia. The group has representatives from Logistic Service Providers, Shippers, Solution Providers and GS1 Member Organizations from around the world and is focused on enabling improved efficiency, interoperability, connectivity and visibility challenges across the Freight & Logistics process due to the fragmented nature of the industry,

The Scan4Transport Standards developed were ratified August 2020.

### 2.1 Transport Industry Challenges

The Freight Transport Industry is extremely fragmented with 40,000 Logistic Service Providers in Australia alone and millions around the world to support the delivery of different types of freight (e.g. bulk, satchels, parcels, pallets, ugly freight, etc), to different locations (e.g. metro, regional, interstate, international), via different service levels (e.g. standard, overnight, same day express, etc). Most of the businesses across the supply chain use different systems, each with their own proprietary standard ("language") for encoding data into barcodes on the Transport Label and sharing information (e.g. transport instructions and status notifications). Subsequently, connecting the different systems ("learning and translating the different languages") and automating processes to capture data across supply chains is not always cost effective. This causes manual processes, duplicated effort, cost and freight visibility delays/gaps for companies across the supply chain as freight is often handled by multiple logistic service providers in the journey from A to B.

The Scan4Transport Work Group surveyed industry participants to determine the key transport challenges they were aiming to solve with the new Scan4Transport Standards:

	<p><b>Lack of interoperability</b> – Many parties in the supply chain have different systems with their own proprietary format ("language") for encoding transport data into barcodes on the Transport Label and sharing information (e.g. transport instructions and status notifications).</p>
	<p><b>Inefficiency</b> – Each party in the supply chain needs to develop and maintain the different barcode formats found across the supply chain within their systems. Relabelling and manual processes resulting from the different formats are other consequences impacting the efficiency of these businesses.</p>
	<p><b>Poor resilience</b> – When electronic transport instructions have not been exchanged prior to the freight being handled, the movement of freight is often impacted until the instructions have been sourced or manually processed.</p>
	<p><b>Freight visibility challenges</b> – There are often visibility gaps or delays when Supply Chains rely on information being passed in a daisy-chain style from party to party along the supply chain or not all systems in the supply chain are connected.</p>

	<p><b>Lack of Agility</b> – When parties in the Supply Chain can only follow the transport instructions on the label, agility is impacted. There are many reasons the transport instructions may change while the freight is travelling though the supply chain (e.g. the receiver will not be at home when the freight is expected to arrive). If all of the systems across the fragmented supply chain are not integrated/connected electronically, the updated instructions may not be received, resulting in a futile delivery when the updated requirements may have provided authority to leave the goods.</p>
---	--

Note: Percentages in the table above are based on data obtained from 21 qualitative survey responses.



### 3 About Scan4Transport Standards

To address the challenges across the freight transport process, the new Scan4Transport Standards developed and piloted are a “global language” for encoding the minimum data required by parties across the supply chain to enable the freight transport process, into a 2D barcode. This information includes a globally unique freight unit identifier (Serial Shipping Container Code – SSCC), and can include:

- Ship-to information (e.g. company, contact, address, phone number, etc),
- Handling information (e.g. routing codes, service descriptions, authority to leave the freight at the delivery point if no one is available to receipt the goods, etc) and
- Return-to information (e.g. company, contact, address, phone number, etc).

As the Scan4Transport standards are technology agnostic, they can be incorporated into existing systems across the supply chain to enable everyone to “talk a common language.” This makes it easier and more cost effective for businesses to adopt technology and connect with each other.

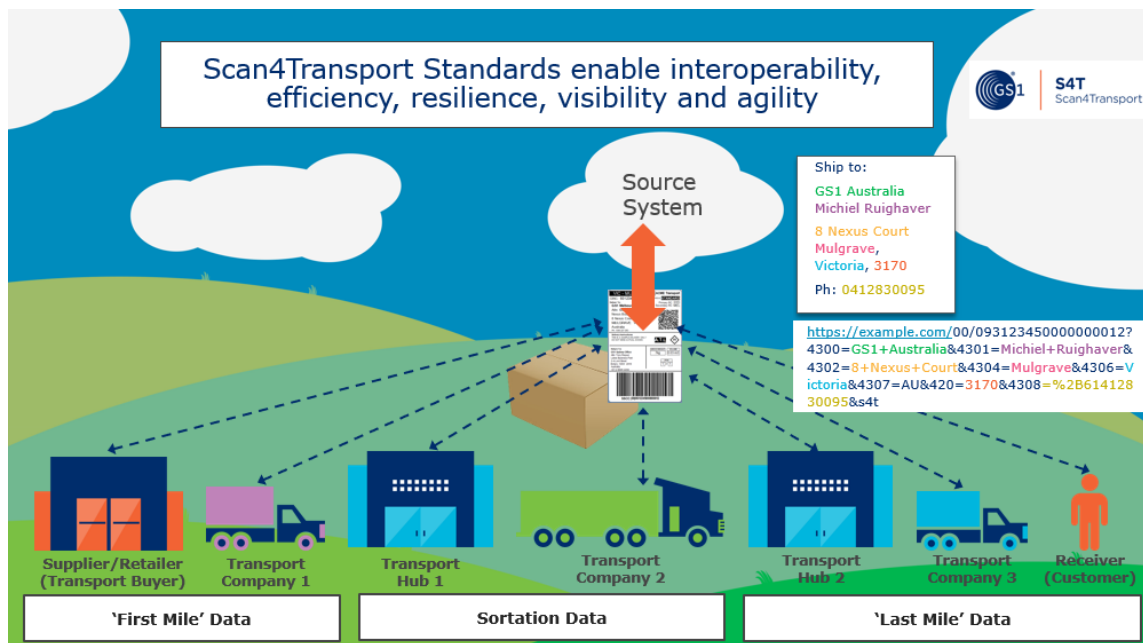

#### 3.1 Scan4Transport Benefits

##### 3.1.1 Interoperability

Interoperability was a key challenge highlighted by the Scan4Transport Work Group and pilot participants. While shippers commonly use 5 or more Logistic Service Providers, larger shippers rely on 50-100 Logistic Service Providers to meet their transport needs. The number of Logistic Service Providers explodes significantly when the subcontractors involved in the movement of freight are included. As each party has their own proprietary transport label format, interoperability suffers. Pilot participants indicated that the Scan4Transport standards enable them to promote/use a transport labelling format that is platform and trading partner independent. Over time, this standard will enable them to start reducing the number of labelling formats they need to support within their business and across the supply chain, improving interoperability.

### 3.1.2 Efficiency

Efficiency challenges highlighted by work group and pilot participants included manually capturing freight requirements into systems when the information was not available (e.g. not received, not accessible, or not encoded in the barcode). The barcodes on the transport label in some of the supply chains contained little more than a reference key, resulting in parties (especially those involved in the last mile process) manually manifesting the freight/recording the freight requirements, manually planning routes and manually creating delivery reports. Being able to capture the data via the barcode was seen as a significant improvement to efficiency.

The effort to create, interpret and manage the many 100's of proprietary labelling/barcoding formats specified by the shipper and Logistic Service Providers (transport partners) created inefficiencies within businesses and unnecessarily complicated the process to connect with new shippers and logistic service providers across the supply chain. In some cases participants specified their proprietary requirements on downstream partners, resulting in downstream inefficiencies. The adoption of a standardised Scan4Transport label, meant additional data could be captured, while reducing manual processes and providing a consistent approach for supply chain partners.

In addition to the proprietary structure of the data in the barcode, other factors such as where human readable data is located on the label presented challenges for pilot participants, especially when manually trying to sort the freight as it is travelling along a conveyer belt. A standard approach to labelling the freight would also improve these activities.

### 3.1.3 Resilience

Work Group and pilot participants indicated that up to 10% of freight could be going through their network before they had received an electronic manifest. For some companies and freight profiles, this could increase to 20% of freight. For micro (mum and dad) logistic service providers this can jump to 40-50% of freight. An example scenario when freight can be handled before the electronic manifest is received are scheduled pickups, where the Logistic service provider has one or more pickups at a particular site in a day but does not receive the batch of manifests till the end of the day. Other examples are drop-in pickups and some of the transport companies in remote/rural areas.

Currently, the Logistic Service providers used the freight ID in the barcode to create a temporary consignment in their systems so that they can link event data when the electronic consignment is received (sometimes they are never received). Being able to capture more detailed information (e.g. address, service details, etc) from the Scan4Transport 2D barcode, enables the Logistic Service Providers to be more resilient by creating a comprehensive temporary consignment which enables automation (i.e. routing processes and final mile execution).

### 3.1.4 Visibility

Freight visibility is a challenge for both shippers, logistic service providers and the recipient.

Shippers - Freight visibility can be delayed or challenging when relying on the systems of all Logistic Service Providers in a journey to be connected or waiting for manual processes to be completed. The GS1 Digital Link in the Scan4Transport label can address this challenge by enabling all parties across the supply chain to locate the source system and potentially update the status of the freight. The ability to electronically capture relevant transport data from the barcode can also automate manual processes and provide more timely reporting on the status of the freight.

Logistic Service Providers - Freight visibility can be impacted when a driver has picked up freight before the manifest has been received. By enabling core information (e.g. ship-to address) to be captured from the Scan4Transport label, the freight can be instantly manifested enabling relevant parties to have better visibility of the freight before they receive it (e.g. the depot are able to plan the freight for the linehaul truck as soon as the first mile driver picks up the freight).

Recipient - Similar to shippers, freight visibility can be delayed or challenging when relying on the systems of all Logistic Service Providers in a journey to be connected or waiting for manual processes to be completed. The GS1 Digital Link in the Scan4Transport label can address this challenge by enabling all parties across the supply chain to locate the source system and potentially update the status of the freight. The ability to encode contact information (e.g. ship-to phone

number) in the Scan4Transport barcode could also improve freight visibility through notifications by the Logistic Service Provider's system that their freight has been picked up or is on route to be delivered.

### **3.1.5 Agility**

The Scan4Transport standards enable access to a digital twin of the transport unit, which is vendor and platform independent. Access to the valuable freight data, without traditional system integration and little impact to existing systems, was seen as a major step forward for last mile execution. The ability of the "freight to talk" created opportunities for pilot logistic service providers to pivot if required (e.g. if the recipient is not expecting to be home). Subsequently, instead of a failed delivery, the logistic service provider would be able to route the transport unit to a parcel locker or receive authority to leave the goods. This was seen as a great opportunity to enhance the quality of service they offered their customers.

## 4 GS1 keys and AIs used in Scan4Transport solution

### 4.1 Expressing data using GS1 Application Identifiers

GS1 Application Identifiers enable a set of attribute:value pairs of data to be encoded in a data carrier. Each attribute within a pair is a GS1 Application Identifier (AI) expressed as a numeric string, e.g. '00' is the AI corresponding to the SSCC, '420' is the AI for the ship-to / deliver-to postal code. The value is the corresponding value for each GS1 Application Identifier. For example, '106141412345678908' is an example value for the SSCC where the attribute AI is '00'.

### 4.2 GS1 keys and AIs used in Scan4Transport solution

Application Identifier	Data Content	Format
<b>00</b>	Serial Shipping Container Code (SSCC)	N2+N18
<b>330n</b>	Logistic weight, kilograms	N4+N6
<b>331n</b>	Length of first dimension, metres	N4+N6
<b>332n</b>	Width, diameter, or second dimension, metres	N4+N6
<b>333n</b>	Depth, thickness height, or third dimension, metres	N4+N6
<b>336n</b>	Logistic volume, cubic metres	N4+N6
<b>401</b>	Global Identification Number for Consignment (GINC)	N3+X..30
<b>402</b>	Global Shipment Identification Number (GSIN)	N3+N17
<b>403</b>	Routing Code	N3+X..30
<b>410</b>	Ship to – Deliver to Global Location Number (GLN)	N3+N13
<b>413</b>	Ship for - Deliver for - Forward to Global Location Number	N3+N13
<b>420</b>	Ship to – Deliver to postal code within a single postal authority	N3+X..20
<b>8003</b>	Global Returnable Asset Identifier	N4+N14+X..16

### 4.3 Ship-to AIs used in Scan4Transport solution

Application Identifier	Data Content	Format	Example
4300	Ship-to / Deliver-to Company Name	N4+X..35	Transport LAMBOLLEY
4301	Ship-to / Deliver-to Contact	N4+X..35	Jeanne d'Arc
4302	Ship-to / Deliver-to Address line 1	N4+X..70	Zone Industrielle des feuilles, Zone A
4303	Ship-to / Deliver-to Address line 2	N4+X..70	21 Rue des entrepôts
4304	Ship-to / Deliver-to Suburb	N4+X..70	SEYSSUEL
4305	Ship-to / Deliver-to Locality	N4+X..70	Isère
4306	Ship-to / Deliver-to Region	N4+X..70	Auvergne-Rhône-Alpes
4307	Ship-to / Deliver-to Country Code	N4+X1X2	FR
4308	Ship-to / Deliver-to telephone number	N4+X..30	611300227263

### 4.4 Return-to AIs used in Transport solution

Application Identifier	Data Content	Format	Example
4310	Return-to Company Name	N4+X..35	GS1 Sydney
4311	Return-to Contact	N4+X..35	John Smith
4312	Return-to Address line 1	N4+X..70	Lakes Business Park
4313	Return-to Address line 2	N4+X..70	2-4 Lord St
4314	Return-to Suburb	N4+X..70	Botany
4315	Return-to Locality	N4+X..70	Sydney
4316	Return-to Region	N4+X..70	NSW
4317	Return-to Country Code	N4+X1X2	AU
4318	Return-to Postal Code	N4+X..20	2019
4319	Return-to telephone number	N4+X..30	611300227263

### 4.5 Handling AIs used in Scan4Transport solution

Application Identifier	Data Content	Format	Description	Example
4320	Service code description	N4+X..35	Freight service code specifies if it is a standard, express, overnight, same day service, etc. This will be unique text from the shipper.	Express
4321	Dangerous Goods Flag	N4+N1	A flag to indicate if the freight unit contains Dangerous Goods 0 (indicates not a dangerous good) 1 (indicates a dangerous good)	0
4322	Authority to leave	N4+N1	This indicates to the operator that they may leave the transport unit at the destination location if required without handing it to a person 0 (meaning "no") 1 (meaning "yes")	1

Application Identifier	Data Content	Format	Description	Example
4323	Signature Required Flag	N4+N1	This indicates to the operator that they must get a signature from the recipient for having delivered the transport unit to the intended destination. 0 (meaning "no") 1 (meaning "yes")	0
4324	Not before Delivery Date Time	N10	In transportation, it is a common business requirement to not deliver before a set date.	YYMMDDHHMM
4325	Not after Delivery Date Time	N10	In transportation, it is a common business requirement to deliver before a set date.	YYMMDDHHMM
4326	Release date	N6	Transport service providers may be required to "hold" transport units for a while before they are allowed to be sent out to recipients.	YYMMDD

#### 4.6 Handling of percent encoding in programming.

The Scan4Transport approach supports the encoding of key information relating to the transport approach for languages using Latin and non-Latin characters. The non-Latin characters are encoded using percent-encoding.

Many programming languages provide built-in functions for percent-encoding and percent-decoding, as indicated in the table below:

Programming language	Function for percent-encoding	Function for percent-decoding
JavaScript	<code>encodeURIComponent(str)</code>	<code>decodeURIComponent(str)</code>
Java	<code>java.net.URLEncoder.encode(str, StandardCharsets.UTF_8)</code>	<code>java.net.URLDecoder.decode(str, StandardCharsets.UTF_8)</code>
Python	<code>urllib.parse.quote(str)</code>	<code>urllib.parse.unquote(str)</code>
.Net	<code>Uri.EscapeDataString(str)</code> OR <code>HttpUtility.UrlEncode(str)</code>	<code>Uri.UnescapeDataString(str)</code> OR <code>HttpUtility.UrlDecode(str)</code>

## 5 Scan4Transport Pilot

There were two approaches piloted. The GS1 element string approach was seen as a transitional step for companies with existing GS1 compliant implementations. This approach uses the GS1 DataMatrix or GS1 QR code symbols. The work group recommends that new implementations should use GS1 Digital Link URI encoded in Data Matrix or QR Code symbols.

### GS1 Application Identifiers and their values

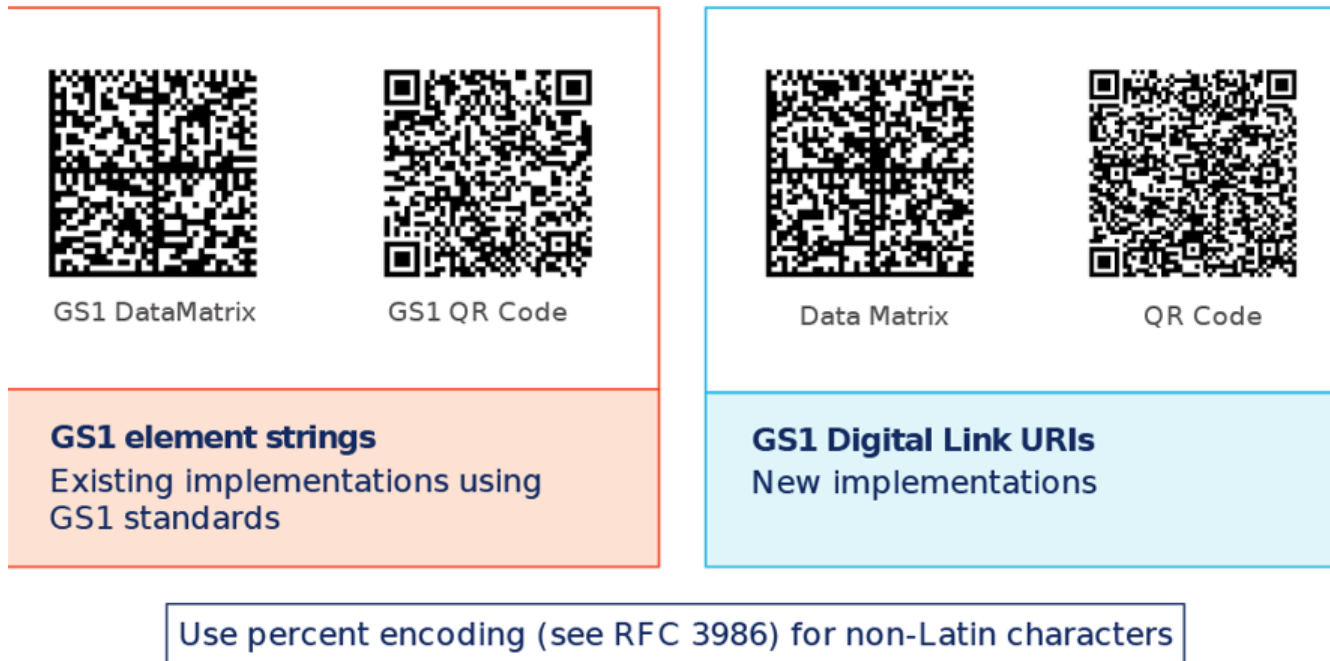

#### 5.1 Concatenated GS1 Element String Approach

In GS1 barcodes such as GS1 DataMatrix and GS1 QR Code, such attribute:value pairs are expressed as element strings that are concatenated according to rules defined in sections 7.8 and 7.8.5 of the *GS1 General Specifications*.

For more information on this approach please see the [Scan4Transport Implementation Guideline](#) ratified August 2021.

#### 5.2 GS1 Digital Link URI AI Approach

GS1 Digital Link URI provides an alternative syntax for expressing such attribute :value pairs as a Web URI that can directly link to information and services on the Web. GS1 Digital Link URI can be encoded in data carriers that support the encoding of URLs or Web URIs. These include QR Codes, NFC tags or DataMatrix symbols. Note that NFC tags, along with QR Code and DataMatrix symbols encoded with a GS1 Digital Link URI based on an SSCC are not yet approved as a GS1 data carrier.

GS1 Digital Link is a method by which a range of specific business objectives may be achieved. For the purposes of transport, GS1 Digital Link provides a means to encode standardized transport process information within a 2D barcode traveling with a transport unit. This information can be used to support transport business processes in the absence of a connection to a remote database. Conversely, GS1 Digital Link can be used to support other applications when an Internet connection is available.

When GS1 Digital Link URI syntax is used within Scan4Transport applications, the SSCC and its value are always encoded within the URI path information, while all other GS1 Application Identifiers are expressed via the URI query string.

The following diagram illustrates the equivalence between the element string notation used in GS1 data carriers such as GS1 DataMatrix and GS1 QR Code and the corresponding GS1 Digital Link URI syntax that could be used within a QR Code or DataMatrix symbol.

**GS1 Digital Link URI**

`https://example.com/00/195212342345678909?4300=Caf%C3%A9+Ni%C3%A7oise&4302=Avenue+Louise+326&4305=Bruxelles&4307=BE&420=1050&4323=1`

encoded in regular QR Code



Data field	Attribute (GS1 AI)	Encoded value	Decoded value
SSCC	00	195212342345678909	195212342345678909
Ship-to Company name	4300	Caf%C3%A9+Ni%C3%A7oise	Café Niçoise
Ship-to address line 1	4302	Avenue+Louise+326	Avenue Louise 326
Ship-to locality	4305	Bruxelles	Bruxelles
Ship-to country code	4307	BE	BE
Ship-to postal code	420	1050	1050
Signature required	4323	1	Yes

**GS1 element string**

`(00)195212342345678909 (4300)Caf%C3%A9+Ni%C3%A7oise(4302)Avenue+Louise+326 (4305)Bruxelles (4307)BE (420)1050 (4323)1`

encoded in GS1 DataMatrix



or GS1 QR code



### 5.3 Scan4Transport 2D Symbologies

DataMatrix ECC 200 and QR Code are 2D symbologies that are not reserved exclusively for GS1 use. They are used by the wider community beyond GS1 and can support native encoding of a URL or Web URI, including a GS1 Digital Link URI. Symbology identifier ]d1 indicates DataMatrix ECC 200. Symbology identifier ]Q1 indicates QR Code. Throughout this document, these are referred to as 'regular' DataMatrix and 'regular' QR Code, to distinguish them from GS1 DataMatrix and GS1 QR Code described below, which are exclusively used for encoding element string syntax, NOT GS1 Digital Link URI syntax.

Additionally, GS1 approves a specific encoding within DataMatrix and QR Code symbologies, which it uses exclusively for encoding element string syntax. GS1 refers to this practice as GS1 DataMatrix and GS1 QR Code. Symbology identifier ]d2 indicates GS1 DataMatrix, while symbology identifier ]Q3 indicates GS1 QR Code.



Symbology	Symbology Identifier	Use
'regular' DataMatrix ECC 200	]d1	Encode Web URIs or URLs, including GS1 Digital Link URIs Not reserved for exclusive use by GS1.
'regular' QR Code	]Q1	
GS1 DataMatrix	]d2	Encode GS1 element string syntax. Reserved for exclusive use by GS1
GS1 QR Code	]Q3	

## 6 Using GS1 Digital Link based approach

### 6.1 GS1 Digital Link data

GS1 Digital Link is a method by which a range of specific business objectives may be achieved. For the purposes of transport, GS1 Digital Link provides a means to encode standardized transport process information within a 2D barcode traveling with a transport unit. This information can be used to support transport business processes in the absence of a connection to a remote database. Conversely, GS1 Digital Link can be used to support other applications when an Internet connection is available. Note that the GS1 General Specifications currently only recognise GS1 Digital Link for use in consumer-facing applications for extended packaging for products. Prototyping for wider use of GS1 Digital Link in other applications/sectors is underway.

### 6.2 Recommended data carriers

When using GS1 Digital Link syntax, the Scan4Transport compliant transport label should encode relevant transport-process data elements using the GS1 Digital Link syntax (<https://www.gs1.org/standards/gs1-digital-link>) within a QR Code (ISO/IEC 18004) or Data Matrix (ISO/IEC 16022). The pilot participants used QR Code.

### 6.3 Example GS1 Digital Link URI with S4T data in URI query string

<https://TransportUnit.Seller.com/00/3952110010013000121?4300=GS1+AISBL&4302=Avenue+Lo uise+326&4305=Bruxelles&4307=BE&420=1050&403=123%2B1021JK%2B0320%2B12%0B&s4t>



This could be translated offline to XML or JSON or an HTML table, as shown in the examples of sections 6.4, 6.5 and 6.6. Note that GS1 Application Identifiers only support a flat list of attribute:value pairs in which the attribute is a GS1 Application Identifier such as (4302), whereas GS1 data models such as the [GS1 Web vocabulary](#) or GDSN data model would typically use a more hierarchical data structure

In these examples, instead of defining two separate XML elements <shipToStreetAddress1> and <returnToStreetAddress1> or properties such as "shipToStreetAddress1" and "returnToStreetAddress1", it is sufficient to define a single XML element <streetAddress> or JSON/JSON-LD property/attribute "streetAddress" and to re-use this within nested parent elements <shipTo><address> or <returnTo><address> in order to distinguish between the ship-to street address line 1 (4302) and the return-to street address line 1 (4312).

The following diagram illustrates this hierarchical data modelling in the GS1 Web vocabulary.

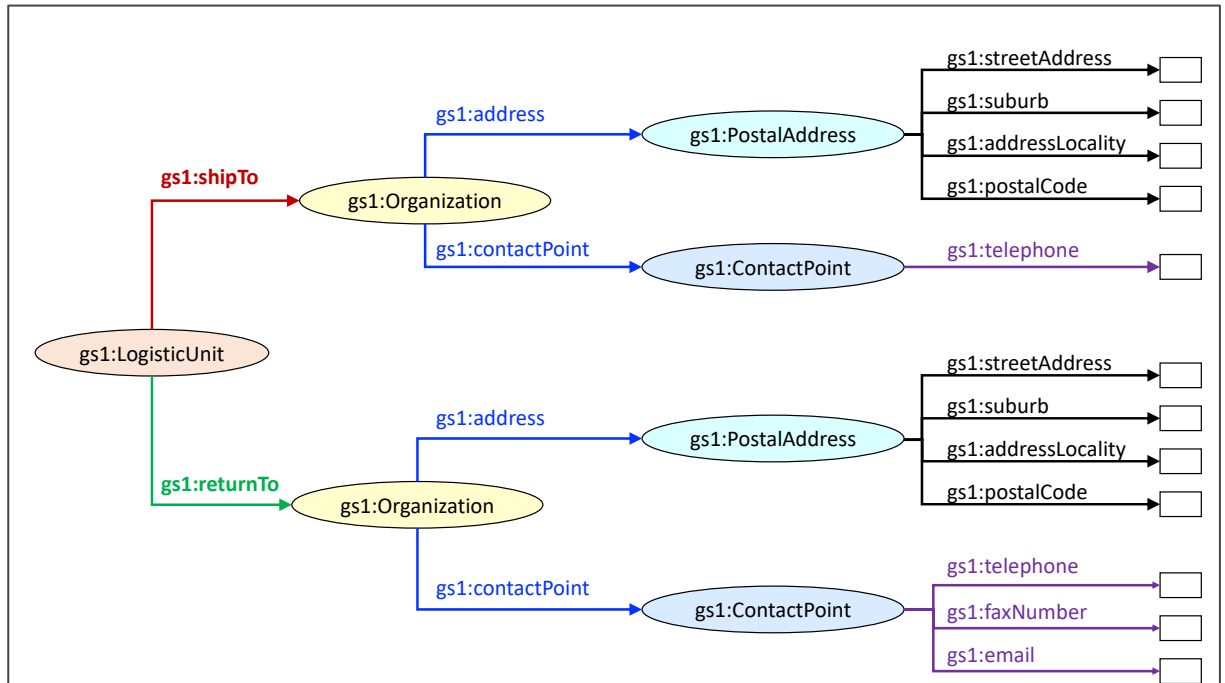

To align with schema.org, the GS1 Web vocabulary models its property / attribute for contact telephone number within a `gs1:ContactPoint` class, not within the `gs1:PostalAddress` class. New properties within the GS1 Web vocabulary (expected to be `gs1:shipTo` and `gs1:returnTo`) will link a `gs1:LogisticUnit` to a `gs1:Organization`. Existing property `gs1:address` links a `gs1:Organization` to a `gs1:PostalAddress` class, while existing property `gs1:contactPoint` links a `gs1:Organization` to a `gs1:ContactPoint` class that includes properties such as `gs1:email`, `gs1:telephoneNumber` and `gs1:faxNumber`. By aligning with this hierarchical approach, there is no need to define two properties for each address data field / attribute, one for the ship-to / deliver-to address, the other for the return-to address.

## 6.4 Example XML translation

Below is an illustrative example of how the data contained within the Scan4Transport identifiers could be expressed as an XML data structure.

```
<sscc>3952110010013000121</sscc>
<shipTo>
  <address>
    <companyName>GS1 AISBL</companyName>
    <streetAddress1>Avenue Louise 326</streetAddress1>
    <addressLocality>Bruxelles</addressLocality>
    <postCode>1050</postCode>
    <countryCode>BE</countryCode>
  </address>
</shipTo>
```

## 6.5 Example JSON translation

Below is an equivalent example of the same hierarchical data structure, expressed in JavaScript Object Notation (JSON). This is slightly more compact than XML and may be easier to use in modern programming/scripting languages. The [GS1 S4T Digital Link toolkit](#) will be capable of translating an element string or GS1 Digital Link URI to such a JSON data structure.

```

{
  "id": "https://TransportUnit.Seller.com/00/3952110010013000121" ,
  "isA": "LogisticUnit",
  "sscc": "3952110010013000121",
  "shipTo": {
    "isA": "Organization",
    "address": {
      "isA": "PostalAddress",
      "organizationName": "GS1 AISBL",
      "streetAddress": "Avenue Louise 326",
      "addressLocality": "Bruxelles",
      "postalCode": "1050",
      "addressCountry": { "countryCode": "BE" }
    }
  }
}

```

## 6.6 Example JSON-LD translation and RDF Turtle

Below is an equivalent example of the same hierarchical data structure, expressed in JavaScript Object Notation for Linked Data format (JSON-LD). The [GS1 S4T Digital Link toolkit](#) will be capable of translating an element string or GS1 Digital Link URI to such a JSON-LD data structure.

```

{
  "@context": {
    "gs1": "https://gs1.org/voc/",
    "rdf": "http://www.w3.org/1999/02/22-rdf-syntax-ns#",
    "rdfs": "http://www.w3.org/2000/01/rdf-schema#",
    "xsd": "http://www.w3.org/2001/XMLSchema#",
    "@vocab": "https://gs1.org/voc/",
    "id": "@id",
    "isA": "@type"
  },
  "id": "https://TransportUnit.Seller.com/00/3952110010013000121" ,
  "isA": "LogisticUnit",
  "sscc": "3952110010013000121",
  "shipTo": {
    "isA": "Organization",
    "address": {
      "isA": "PostalAddress",
      "organizationName": "GS1 AISBL",
      "streetAddress": "Avenue Louise 326",
      "addressLocality": "Bruxelles",
      "postalCode": "1050",
      "addressCountry": { "countryCode": "BE" }
    }
  }
}

```

RDF Turtle is another Linked Data format complementary to JSON-LD. The above example would probably look like this in RDF Turtle:

```

@prefix gs1: <https://gs1.org/voc/> .
@prefix rdf: <http://www.w3.org/1999/02/22-rdf-syntax-ns#> .
<https://TransportUnit.Seller.com/00/3952110010013000121> rdf:type
gs1:LogisticUnit .

```

```

<https://TransportUnit.Seller.com/00/3952110010013000121> gs1:shipTo _:b0 .
<https://TransportUnit.Seller.com/00/3952110010013000121> gs1:sscc
"3952110010013000121" .
_:b0 rdf:type gs1:Organization .
_:b0 gs1:address _:b1 .
_:b1 rdf:type gs1:PostalAddress .
_:b1 gs1:organizationName "GS1 AISBL" .
_:b1 gs1:streetAddress "Avenue Louise 326" .
_:b1 gs1:addressLocality "Bruxelles" .
_:b1 gs1:postalCode "1050" .
_:b1 gs1:addressCountry _:b2 .
_:b2 gs1:countryCode "BE" .
  
```

### 6.7 Example HTML Table

A Web page might display the decoded information as a table, as shown below – or even formatted to resemble the layout of a shipping label as shown in the diagram of section 6.8.

Element	Description	Example
00	SSCC	3952110010013000121
4300	Ship-to Company Name	GS1 AISBL
4302	Ship-to Street Address 1	Avenue Louise 326
4304	Ship-to Suburb	Bruxelles
420	Ship-to Postal Code	1050
4307	Ship-to Country Code	BE (Belgium)

### 6.8 Example S4T Logistic Label (GS1 Digital Link approach)

The image on the right shows a Logistic Label using the GS1 Digital Link approach to implement Scan4Transport.

The label still shows the SSCC in the GS1-128 linear barcode format as mandated by GS1 General Specifications and the Logistic Label Guideline. This means more traditional stakeholders in the supply chain may still use the linear barcode to access information regarding the transport unit.

The label also includes a regular QR code encoding the following information (See next paragraph for more details on the structure of the barcode content):

1. A URI path to Web resource  
"https://example.com/00/3952110010013000121"
2. AI 00 – SSCC  
3952110010013000121  
appears as part of the URI path to the Web resource shown above
3. AI 4307 – Ship-to/Deliver-to Country Code  
NL

**FJP CARRIERS**

**FROM** GS1  
Avenue Louise 326  
1050 BE BRUXELLES  
BE – Belgique  
GLN: 95211001100011

**TO** Hr. F. van den Bos  
Poincaréstraat 319  
1500 KM Wormerveer  
NL – Nederland

+32 123456789

---

SSCC 3952110010013000121  
ROUTE 123+1021JK+0320+12  
SHIP TO POST 1500 KM



---



(00) 3 95211001 00130012 1

4. AI 420 – Ship-to/Deliver-to Postal Code  
"1500 KM"  
(encoded as 1500+KM)
5. AI 403 – Routing Code  
"123+1021JK+320+12"  
(encoded as 123%2B1021JK%2B320%2B12)
6. An indicator that the QR code contents have been constructed according to the rules for Scan4Transport. This indicator always appears at the end of the URI.  
"&s4T"

Stakeholders able to process the S4T barcode may suffice with scanning the 2D barcode only. They would be able to access additional information regarding the transport unit based on the SSCC and the URI path to the Web resource. Alternatively, they may use the other data elements in the S4T barcode for handling the transport unit correctly (e.g. during sorting using automated systems).

### 6.9 Recommendations for constructing a GS1 Digital Link URI

The GS1 Digital Link standard requires that the content of the URI starts with `http://` or `https://` followed by the hostname and any URI path information. For a GS1 Digital Link URI based on an SSCC identifier, the URI path information consists of `/00/` followed by the 18-digit SSCC value.

Within the context of GS1 Scan4Transport, any GS1 Application Identifiers other than SSCC (00) should be expressed in the URI query string, which follows after a `?` delimiter after the URI path information.

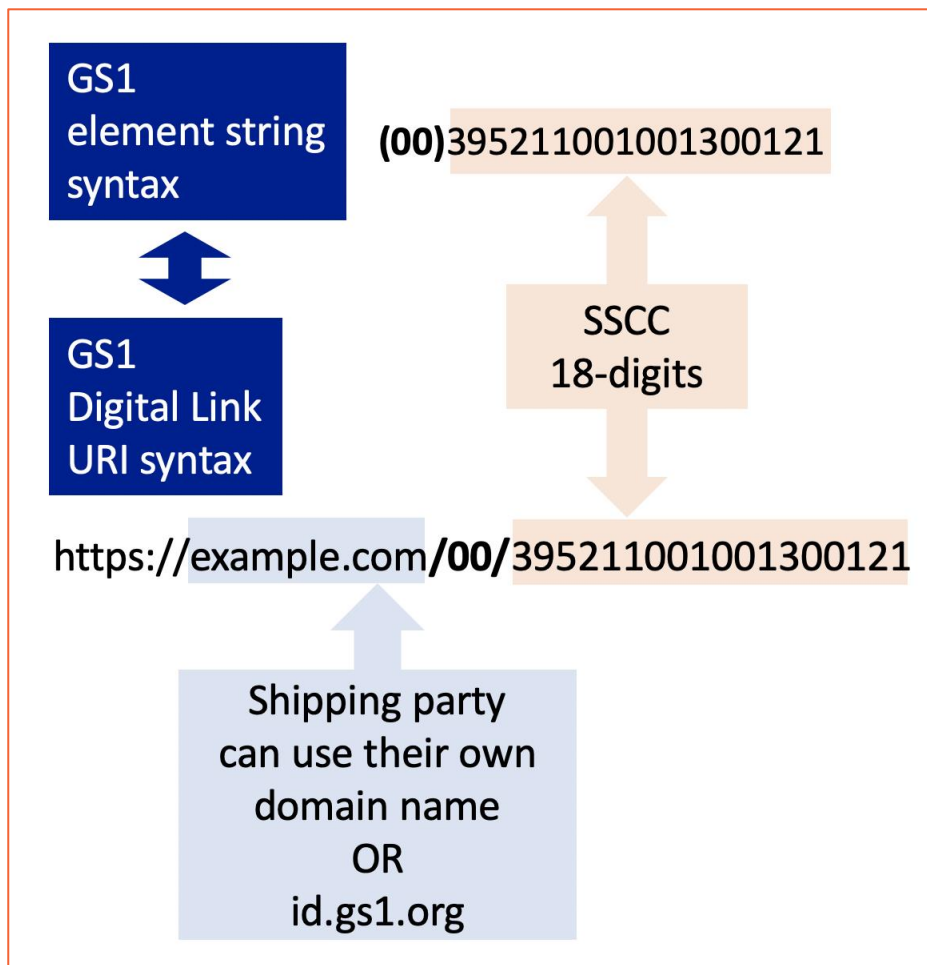

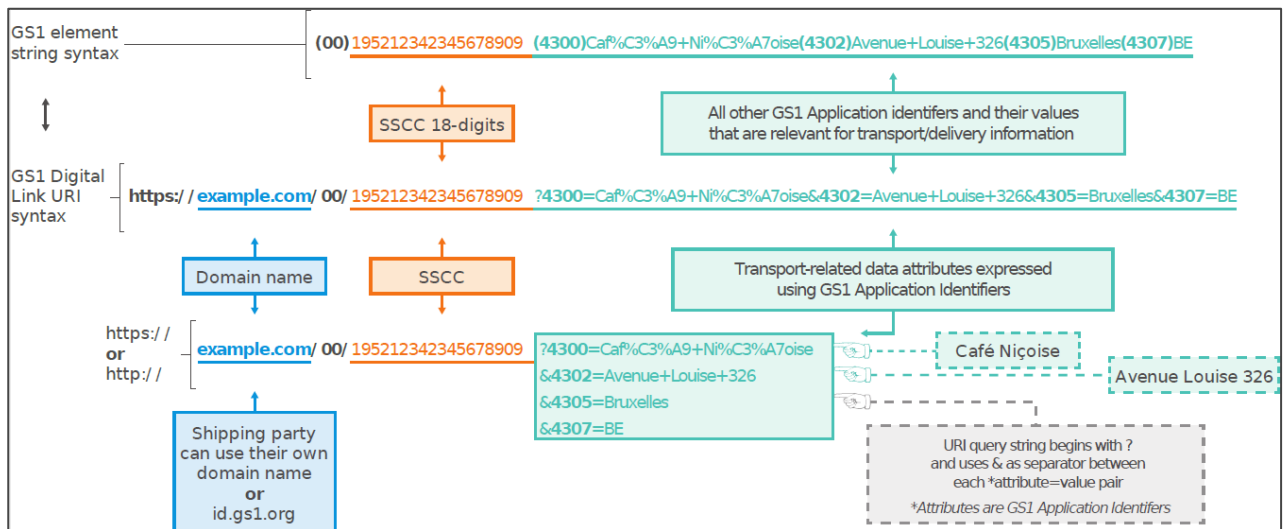

In the above examples, we used the URL `https://TransportUnit.Seller.com/00/{sscc}`

This is best explained processing the URL from right to left.

- `{sscc}` provides the unique and unambiguous Transport Unit ID. This ID Key may be used to find the records with the latest information for the Transport Unit;
- `/00/` indicates that the value provided in the `{sscc}` should be interpreted as a GS1 Serial Shipping Container Code (SSCC)
- [TransportUnit.Seller.com](https://TransportUnit.Seller.com) is the domain name used to access the online/Web service that the Seller of the Products transported within the Transport Unit offers (if any) to provide the latest information to handlers of the transport unit (as well as to other parties involved).

The Scan 4 Transport approach does not require that the URL points to an actual live/operational online/ Web service. The Scan 4 Transport approach delivers many benefits to transport operations based on the other components of the GS1 Digital Link URI.

However, as indicated in various places in this document, the information available on the Transport Unit Label may no longer be up to date by the time the handler of the Transport Unit processes the Unit.

In case that handler had access to an online/Web service (using the URL), the handler could avoid processing the transport unit "incorrectly". Imagine a customer who wants to change the Delivery location from his home address to his office address (maybe in the same city and the same handler could make the delivery).

The customer could inform the seller. The seller could simply post the latest information on the Web services that the Seller provides. The handler would immediately see on the mobile device that he/she must now deliver this transport unit to the office address rather than the home address (which is still included in the data on the transport unit label).

By implementing a Web service to provide handlers of the transport unit access to the latest information, the seller has the opportunity to improve the customer experience (avoiding deliveries that do not satisfy the customer).

The shipping company that issues SSCCs may construct GS1 Digital Link URIs using its own domain name or hostname and may operate its own resolver infrastructure or URL rewriting rules within its website to ensure that appropriate data is returned in response to a Web request for a GS1 Digital Link URI containing a specific SSCC.

GS1 makes an open source implementation of a GS1 Digital Link resolver freely available at [https://github.com/gs1/GS1\\_DigitalLink\\_Resolver\\_CE](https://github.com/gs1/GS1_DigitalLink_Resolver_CE)

## 7 Sample Labels

### 7.1 Concatenated AI label

Minimum Data Set	Maximum Data Set
<p>Service: <b>STANDARD</b> <b>ACME Transport</b>            Primary RC: TOK            Secondary RC: SYD</p> <p>Deliver To:  <b>GS1 Japan</b>            ヨッシー            9F, Shin Aoyama Bldg., East            1-1-1, Minami Aoyama            Minato-ku            TOKYO 107-0052            Japan            PH: 1300 227 263</p> <p>Delivery Instructions:            THIS IS A SAMPLE DELIVERY ONLY            DO NOT SEND ACTUAL GOODS</p> <p><b>A.T.L</b> <b>DG</b></p> <p>Return To:  <b>GS1 Sydney Office</b>            Attn: Tony Repaci            Lakes Business Park            2-4 Lord Street            Botany NSW 2019            Australia            +61 2 9695 2200</p> <p>GROSS WEIGHT: 7kg   VOLUME: 0.03 m3            ITEM: 1 of 1</p> <p>(00) 0 9528765 400000001 5</p>	<p>Service: <b>STANDARD</b> <b>ACME Transport</b>            Primary RC: TOK            Secondary RC: SPA</p> <p>Deliver To:  <b>GS1 Japan</b>            ヨッシー            9F, Shin Aoyama Bldg., East            1-1-1, Minami Aoyama            Minato-ku            TOKYO 107-0052            Japan            PH: 1300 227 263</p> <p>Delivery Instructions:            THIS IS A SAMPLE DELIVERY ONLY            DO NOT SEND ACTUAL GOODS</p> <p><b>A.T.L</b> <b>DG</b></p> <p>Return To:  <b>GS1 Brasil</b>            Av. 9 de Julho, 3183            Apt 125            Jardim Paulista            CEP 01407-000 São Paulo SP            Brazil            +55 11 1234 5678</p> <p>GROSS WEIGHT: 7kg   VOLUME: 0.03 m3            ITEM: 1 of 1</p> <p>(00) 0 9528765 400000003 9</p>

### 7.2 GS1 Digital Link label

Minimum Data Set	Maximum Data Set
<p>Service: <b>STANDARD</b> <b>ACME Transport</b>            Primary RC: TOK            Secondary RC: SYD</p> <p>Deliver To:  <b>GS1 Japan</b>            ヨッシー            9F, Shin Aoyama Bldg., East            1-1-1, Minami Aoyama            Minato-ku            TOKYO 107-0062            Japan            PH: 1300 227 263</p> <p>Delivery Instructions:            THIS IS A SAMPLE DELIVERY ONLY            DO NOT SEND ACTUAL GOODS</p> <p><b>A.T.L</b> <b>DG</b></p> <p>Return To:  <b>GS1 Sydney Office</b>            Attn: Tony Repaci            Lakes Business Park            2-4 Lord Street            Botany NSW 2019            Australia            +61 2 9695 2200</p> <p>GROSS WEIGHT: 7kg   VOLUME: 0.03 m3            ITEM: 1 of 1</p> <p>(00) 0 9528765 400000002 2</p>	<p>Service: <b>STANDARD</b> <b>ACME Transport</b>            Primary RC: TOK            Secondary RC: SPA</p> <p>Deliver To:  <b>GS1 Japan</b>            Place Canada            7-3-37 Akasaka            Minato-ku            TOKYO 107-0052            Japan            PH: 1300 227 263</p> <p>Delivery Instructions:            THIS IS A SAMPLE DELIVERY ONLY            DO NOT SEND ACTUAL GOODS</p> <p><b>A.T.L</b> <b>DG</b></p> <p>Return To:  <b>GS1 Brasil</b>            Av. 9 de Julho, 3183            Apt 125            Jardim Paulista            CEP 01407-000 São Paulo SP            Brazil            +55 11 1234 5678</p> <p>GROSS WEIGHT: 7kg   VOLUME: 0.03 m3            ITEM: 1 of 1</p> <p>(00) 1 9521234 000000004 1</p>



## 8 Scan4Transport Pilots

### 8.1 Pilot scope

The pilot scope included:

- New 4300 series identifiers and existing GS1 identifiers relevant to the freight transport process
- Concatenated AI and GS1 Digital Link approaches for encoding data into the 2D barcode
- Both GS1 QR and GS1 DataMatrix barcode symbologies and regular QR and DataMatrix barcode symbologies

The items out-of-scope were:

- Application identifiers not relevant to the freight transport process
- Encoding of data attributes specific to the billing/administration process

### 8.2 Pilot participants



### 8.3 Pilot Streams

Pilot participants were involved in a mix of 3 types of pilots.

#### 8.3.1 Desktop Pilot

The Desktop Pilot involved:

- Analysing and documenting the impact to the pilot participants business if a freight unit using the Scan4Transport standard were to enter their day-to-day operations
- Investigating and documenting the benefits of the new Scan4Transport standards to the pilot participant's business/supply chain

- Identifying and documenting any challenges/barriers for the pilot participant’s business/supply chain to implement the Scan4Transport standards.
- Estimate effort/cost for the pilot participant’s business to implement the scan4Transport standards

### 8.3.2 Lab/Small Pilot

The Lab/Small Pilot involved:

- Physically testing the new Scan4Transport standards inhouse/lab
- Reviewing the scan4transport process from shipper to receiver, across a selected supply chain (which may or may not include a sub-contractor) and evaluating the benefits, challenges, and effort to implement the Scan4Transport Standards

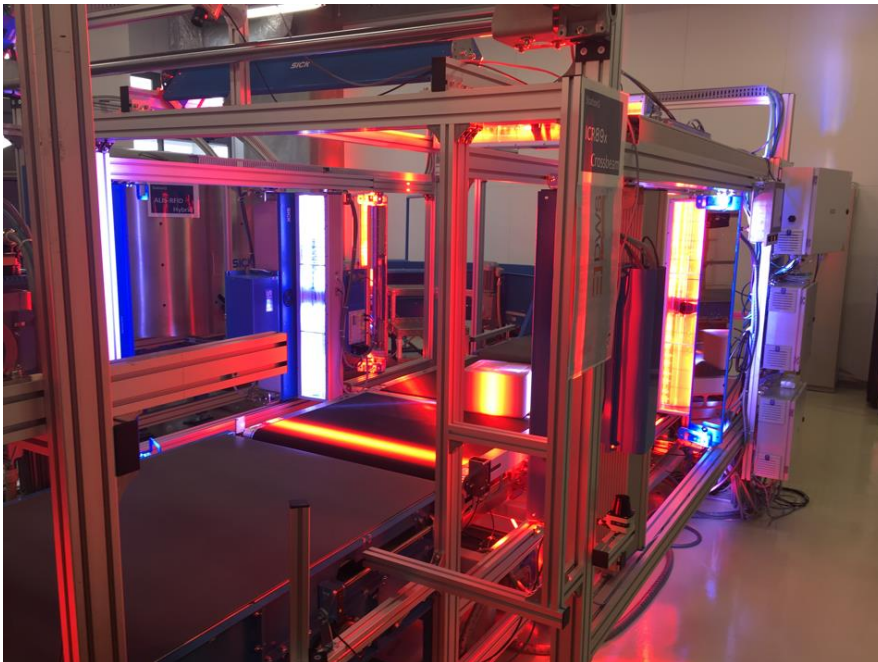

### 8.3.3 Physical/full pilot

The Physical/Full Pilot involved:

- Developing the Scan4Transport standards into existing solutions
- Documenting the benefits of the new Scan4Transport standards to the pilot participant’s business/supply chain
- Capturing the challenges and effort to implement

## 8.4 Test Cases

Pilot testing focused on the following objectives:

1. Validating that the new 4300 series Application Identifiers
2. Confirm that the GS1 standards enable industry to encode the minimum data required to support the transport process into a 2D barcode
3. Testing the GS1 Element String approach
4. Testing the GS1 Digital Link approach

5. Identifying the impact and benefits of the Scan4Transport standards across the transport process, including first mile, sortation and last mile
6. Testing the encoding of non-latin characters to support use across global supply chains
7. Reviewing the inclusion of a Global Returnable Asset Identifier (GRAI) within the scan4transport barcode to support the pallet transfer process
8. Confirming that the large amount of data encoded in the 2D scan4transport barcode does not compromise the performance of automated sortation systems
9. Determine the impact of the 2D scan4transport barcode on common scan technology used within industry
10. Validating that the GS1-128 provides redundancy for participants in the supply chain who are not able to capture the data in the 2D symbol

## 8.5 Learnings

The learnings from the pilots include:

- The new 4300 series Application Identifiers supported industry requirements for encoding key data required to support the transport process
- GS1 Identification keys, new 4300 series and existing AIs enabled the minimum data required to support the transport process to be encoded within the Scan4Transport 2D barcode
- The initial implementation of the rich Scan4Transport standards can be more complex than some proprietary formats. However, as industry adoption of the Scan4Transport approach increases, the cost for shippers and LSPs to setup new trading relationships and run the related IT solutions is expected to decrease
- The rich data in the Scan4Transport approach enables more efficient processes (e.g. reduced admin) for LSPs outweighing the effort to implement
- The Scan4Transport approach enabled resilience and efficiency by eliminating the dependency on EDI to keep the freight transport processes moving and reducing manual data entry
- The rich data in the Scan4Transport barcode and ability to locate the source system, decreases reliance on system integration between parties involved in a supply chain
- The ability for all parties in the supply chain to locate the source system using the GS1 Digital Link standard and rich data within with the Scan4Transport barcode enables increased visibility within and across businesses in the supply chain
- The rich data and processes enabled by the Scan4transport barcode enable LSPs enhance the reporting and customer service they provide to their customers
- The Scan4Transport approach enables both large and small logistic service providers, including agents and subcontractors, to benefit from reduce overhead and more efficient processes
- The comprehensive data available via the Scan4Transport approach has created opportunities for new innovation with solution providers' solutions
- There is no consistent structure for addresses across the globe. Some addresses include only a street and postcode, while others contain suburbs, localities and regions. The Scan4Transport approach enables all combinations of address formats to be encoded using both Latin and non-Latin (e.g. Japanese) characters, making it a truly global solution
- The Scan4Transport barcodes tested had a 100% scan rate on conveyers running at 1-2 metres per second
- The enhanced data in the 2D S4T barcode provides industry with many benefits without slowing down the running speed of auto sortation systems. The timeframe to process S4T barcodes ranged from 101 to 174 milliseconds, providing more than ample time within the typical 500-

600 millisecond window sortation systems have to process the freight

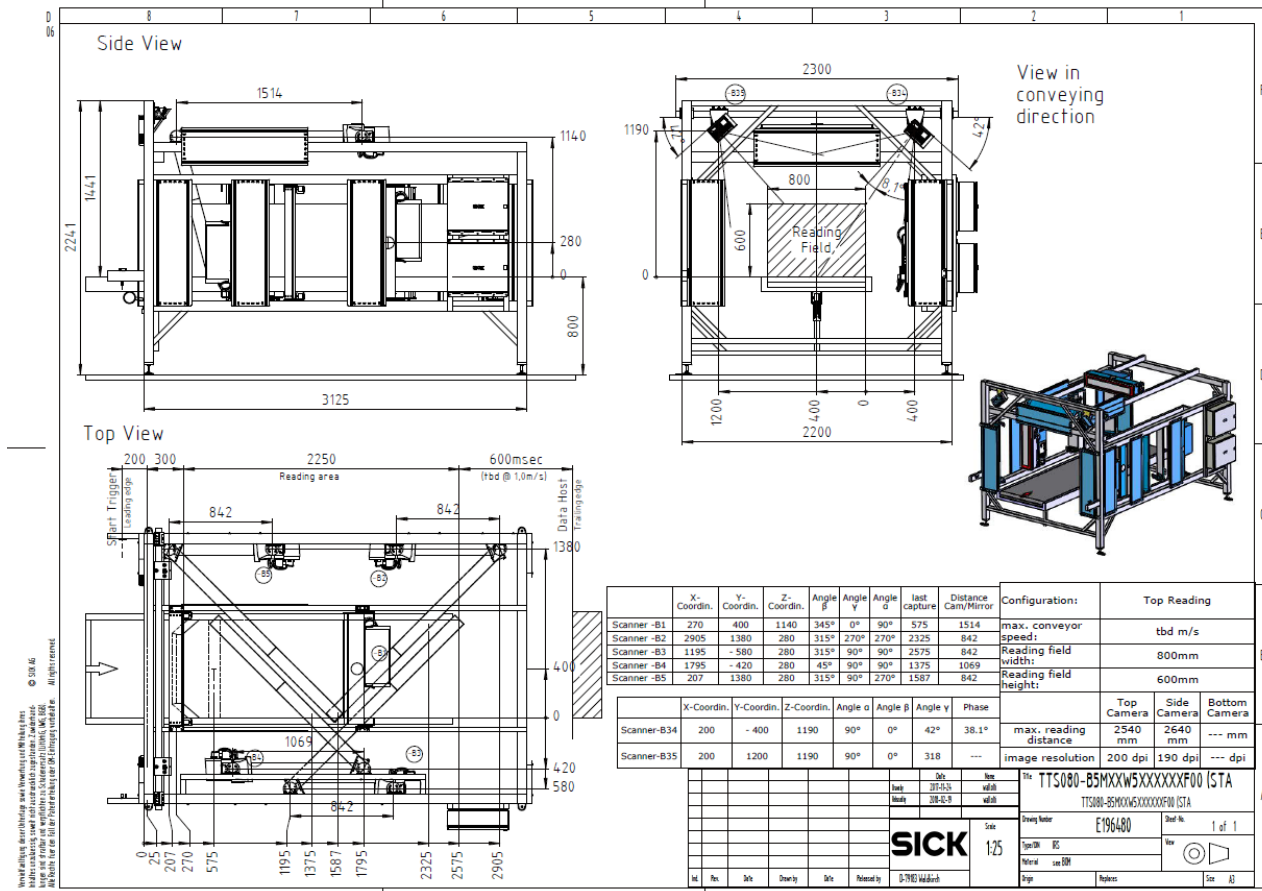

- The Scan4Transport GS1 Digital Link approach was 9.8ms to 12.8ms faster than the AI string approach when decoding the minimum and maximum dataset tested
- The Scan4Transport 2D barcodes were able to be decoded by the typical sortation cameras manufactured in the last 10 years.
- The Global Returnable Asset Identifier (GRAI) was able to be encoded within the scan4transport barcode to support the pallet transfer process
- The Scan4Transport approach provided efficiency, interoperability, resilience and agility right across the transport process, including first mile, sortation and list mile
- The SSCC encoded in the GS1-128 symbol on the Scan4Transport label provided adequate redundancy for participants in the supply chain are not able to capture the data in the 2D symbol
- The Scan4Transport Element String approach will provide industry with migration path to GS1 Digital Link

## 9 Quotes from Industry

"We plan to deploy the SSCC solution for our customers in June/July 2021. The SSCC will replace our current bespoke item identifier which does not have a check digit and can lead to mis reads. We are also planning to go live with the Scan4Transport digital link standard encoded into a 2D barcode in August/September 2021."

**David Pollard – Manager Transport & Logistics Design  
New Zealand Post – Logistic Service Provider**

"The Scan4Transport standards will provide additional resilience at times when electronic transport instructions have not been received. This includes through our automated sortation and routing processes, as well as first and final mile execution. Scan4Transport will also enhance the partner carriers processes we work with in the same way. End result will be enhancing the quality of service for our customers throughout their supply chain."

**Karl Brooks – IT Solutions Architect  
DHL Supply Chain (Australia) – Logistics Service Provider**

"Scan4Transport 'makes freight talk'. The rich information that can be embedded in the labels enables the freight to travel through a logistic network with a high level of both efficiency and redundancy. GS1 Digital Link adds to that by enabling it to 'talk real-time information'."

**Mark Chaston – National Innovation Manager  
Border Express – Logistic Service Provider**

"The Scan4Transport standards will provide benefit to VT Freight Express, its network partners and customers via a standard that supports the provision of uniform and consistent data and physical labelling associated with despatch, in transit and final delivery processes. The many supply chains our business supports all operate bespoke solutions that require specific controls and resource to support, Scan4Transport standards enable interoperability across networks and supply chains and will allow our business and network to be more agile in the provision of the delivery services we offer whilst providing visibility to our customers. "

**Anthony Tanner – CEO  
VT Freight Express – Logistic Service Provider**

"The Scan4Transport standards represent the possibility of using market standardized and interoperable technology. Its use in the future will certainly allow the company to properly operate its processes, providing adequate logistics services to its customers, even in unfavourable technical conditions, such as remote locations (e.g. rural areas) where there is poor coverage of cellular telephony signals and/or data communication, or in contingency situations (e.g. loss of connectivity or communications)"

**Odarci Roque de Maia Junior – RFID Project Manager  
Brazilian Post – Logistic Service Provider**

"The Scan4Transport standard will provide immediate benefit to our customers through interoperability. Very few logistic service providers service the end to end journey of freight. By working together utilising Scan4Transport they are able to immediately exchange valuable freight data with little impact to their existing systems which will provide for efficiency gains and increased customer satisfaction."

**Alex Koumaras – Managing Director  
Leopard Systems – Solution Provider**

"The scan4transport standards will benefit not only our customers, but everyone who participates in the supply chain. Carriers, solution providers, shippers and end customers will all have increased efficiency and visibility of standard transport information."

**Ben Woodward – Global Marketing & Channel Manager  
SmartFreight (Wisetech Global Group) – Solution Provider**

"Scan4Transport standards developed are a highly valuable asset for MIXMOVE. The ability to link the digital twin to the physical object retaining vendor and platform independence is a major step towards building our vision of the physical internet."

**Nuno Bento – Chief Technical Officer  
MIXMOVE – Solution Provider**

## 10 Deployment kit

A Scan4Transport deployment kit was developed for the pilots to support industry and GS1 Member Organisations to promote and implement the new standards. It is recommended that the kit is further developed and made available at <https://www.gs1.org/industries/transport-and-logistics/scan4transport>:

- [Scan4Transport Flyer](#)
- [S4T implementation guideline](#)
- Link to join the [Scan4Transport Work Group](#)
- [GS1 Transport standards animation](#)
- [Scan4Transport Pilot Report video](#)
- Scan4Transport [demo tool](#) for encoding and decoding barcodes
- [ASCLA 2020 International Supply Chain Award](#)
- [2021 Victorian iAWARD Not For Profit and Community Solution of the Year](#)





## 11 Recommendations

The recommendations from the Scan4Transport pilots and work group include:

### 11.1 Promote S4T standards and pilot results within industry

To maximize the benefit of the Scan4Transport standards, pilot participants are looking forward to wider adoption of the standards. Subsequently, the group has recommended GS1 Member Organisations and industry actively promote the standards and pilot report to create awareness of the benefits and encourage adoption.

### 11.2 Develop Deployment Kit including promotional assets for MO's and industry

To help GS1 Member Organisations and Industry promote and adopt the Scan4Transport standards, the group recommended the development of a resource kit containing standards and promotional documents, videos, demo tools, source code, etc.

### 11.3 Migration plan

As the Freight Transport Industry is extremely large and fragmented, it will take time to migrate participants to the standard based Scan4Transport approach. Subsequently, it is important to provide industry with a migration strategy enabling them to transition from proprietary freight identifiers to standard identifiers, proprietary encoding of data to a standards based approach and support for both AI string and GS1 Digital Link approaches.

### 11.4 Encourage additional companies/individuals to participate in [Scan4Transport Work Group/User Group](#) and/or T&L Centre of Excellence

One of the approached suggested to drive awareness and adoption of the standards, is to grow participation in the Scan4Transport Work Group and other user groups to enable industry to share learnings, challenges and strategies. Similarly, it is important for GS1 Member Organisations to leverage the Scan4Transport Centre of Excellence for knowledge and resources.

### 11.5 Recruit additional pilots and encourage industry adoption

To encourage industry to migrate from current proprietary approaches to the standards based Scan4Transport approach, it is important for government, industry associations, GS1 Member Organisations and industry to drive adoption and facilitate additional pilots if required.

### 11.6 Profile implementations

To drive adoption of the Scan4Transport standards, it is important to profile Logistic Service Providers and Shippers that have adopted the standards. In addition to increasing awareness, profiling Logistic Solution Providers that support the standards can encourage Shippers to use the standards with them. Similarly, influential shippers that have adopted the standards can drive Logistic Service Providers to take action adopting the standards.

### 11.7 Promote compliant solutions

In addition to increasing awareness of the Scan4Transport standards, profiling Solution Providers that support the standards can encourage users of the solution (i.e. Shippers and/or Logistic Service Providers) to pilot and/or adopt the standards.

### **11.8 Submit S4T standards for additional Industry Awards**

Awards can and has been a great tool for creating awareness of the Scan4Transport standards. Subsequently, GS1 Member Organisations, Logistic Solution Providers, Shippers and Solution Providers should consider entering awards in their region.

### **11.9 Grow and maintain the Scan4Transport website ([www.gs1.org/industries/transport-and-logistics/scan4transport](http://www.gs1.org/industries/transport-and-logistics/scan4transport))**

To support Industry and GS1 Member Organisations to promote, pilot, adopt the Scan4Transport standards, it is important to provide a central resource everyone can access for the latest information and to provide feedback.

### **11.10 Track industry awareness (e.g. # downloads of [S4T implementation guideline](#))**

It is important to measure and communicate Industry awareness of the Scan4Transport standards. This should include (but is not be limited to) views of the Scan4Transport implementation guideline, pilot report, pilot report video, etc.

## 12 Feedback & Questions

Please let us know if you are implementing the Scan4Transport approach outlined in this document. We welcome feedback and learnings from other pilots and implementations across the globe and encourage you to forward your questions and feedback to:

Michiel Ruighaver

T&L Sector Manager – Scan4Transport Centre of Excellence

GS1 Australia

E: [Michiel.ruighaver@gs1au.org](mailto:Michiel.ruighaver@gs1au.org)

## 13 Appendix

### 13.1 Typographical conventions used in this document

This document includes examples of GS1 Digital Link URIs such as:

```
https://example.com/sscc/{sscc} and
https://example.org/00/{sscc}
```

The use of the monospace font indicates that the text has meaning for computers. Further, these examples follow the convention used in [RFC 6570]. The places where the values of variables should be inserted are written in braces, so, for example, {sscc} means "insert the SSCC value here". All other text in the URI is a literal string to be used as written. As explained in [RFC 2606] and [RFC 6761], the domains example.com, example.org and example.net are second-level domain names reserved by the Internet Assigned Numbers Authority (IANA) for use in documentation. These should be understood as a placeholder for any registered second-level domain name.

### 13.2 References

Reference name	Location
Scan4Transport Implementation Guideline	<a href="https://www.gs1au.org/s4t-guideline">https://www.gs1au.org/s4t-guideline</a>
GS1 General Specifications	<a href="https://www.gs1.org/standards/barcodes-epcrfid-id-keys/gs1-general-specifications">https://www.gs1.org/standards/barcodes-epcrfid-id-keys/gs1-general-specifications</a>
GS1 S4T Digital Link toolkit  Online resources providing the ability to generate a GS1 Digital Link URI and encode it in a QR Code	<a href="https://gs1.github.io/S4T/">https://gs1.github.io/S4T/</a>
GS1 S4T Source Code	<a href="https://github.com/gs1/S4T">https://github.com/gs1/S4T</a>