

Future Stories Test Book

Levels 4–6



Name:

Contents Page

You will complete three interim tests throughout this course. Interim tests will be completed at home and will then be marked and reviewed with your tutor the following week.

Test	Content Covered	Page no.
Interim Test 1 Maths	Place Value, Factors & Multiples, Function Machines, Decimals, Conversion & Measurement, Fractions	6–10
Interim Test 1 English	Comprehension, Commas, Hyphens, Parentheses & Dashes, Nouns, Verbs & Tenses, Plurals, Missing Letters	11–16
Interim Test 1 Writing	Creative Writing	17–20
Answer Sheets	Interim Test 1 Perforated Answer Sheets	21–22
Interim Test 2 Maths	Perimeter & Area, Number Squares, Percentages, Interpreting Data, Mean, Median, Mode & Range, Problem Solving, 3D Shapes	24–29
Interim Test 2 English	Comprehension, Homophones, Colons, Semicolons & Apostrophes, Spelling Tricky Words, Missing Letters	30–35
Interim Test 2 Writing	Creative Writing	36–39
Answer Sheets	Interim Test 2 Perforated Answer Sheets	41–42
Interim Test 3 Maths	Volume & Capacity, Probability, Ratio, Sequences, Special Numbers, Symmetry, 2D Shapes, Transformations, Equations & Algebra	44–49
Interim Test 3 English	Comprehension, Silent Letters, Metaphors & Personification, Subject & Object, Sentences, Phrases & Clauses, Pronouns, Prepositions & Conjunctions, Adverbs, Adverbials & Modal Verbs, Missing Letters, Missing Sentences	50–57
Interim Test 3 Writing	Creative Writing	58–61
Answer Sheets	Interim Test 3 Perforated Answer Sheets	63–65
Mock A Paper 1	English Test	67–85
Mock A Paper 2	Creative Writing Test	87–92
Mock A Paper 3	Maths Test	93–111
Mock B Paper 1	English Test	113–131
Mock B Paper 2	Creative Writing Test	133–138
Mock B Paper 3	Maths Test	139–155

Information for Tests

Interim papers have been scheduled in to the year-long 11 Plus course planner and should be completed only when they appear in the course planner.

Each interim test is broken down into maths, English and creative writing.

ALL TESTS WILL BE COMPLETED AT HOME. Please make sure you bring your book to your lesson the week after a test has been completed, for marking and review.

Your tutor will inform you when a test should be completed.

Marking and Feedback

Once you have completed an 'interim test' you will mark it alongside your tutor. Add your score next to each test on the score sheet on Page 5.

Reflecting helps you to develop your skills and review their effectiveness. To be self-aware is to be able to realistically assess your strengths, areas for development and set goals, while maintaining a positive mindset. You will get some time after each test for self-reflection and an opportunity to use Compass to work on any tricky topics from the test.

There is dedicated time within each course planner to mark and review each test. **If you would like access to the answers for each of the tests within this book, please scan the QR code below.**

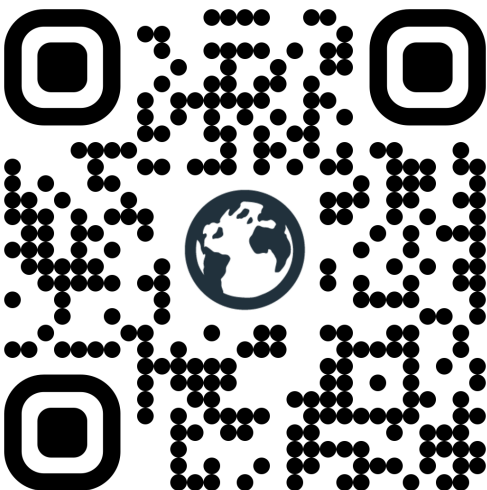

Information for Tests

At the end of each set of tests there will be a perforated answer sheet per subject to mark the correct answer. These pages can be torn out and placed alongside the test paper to mark answers as you are working.

Some of the questions are **multiple choice**. You will need to select your answer by shading one oval on the answer sheet for each question.

You must shade your answers like this:

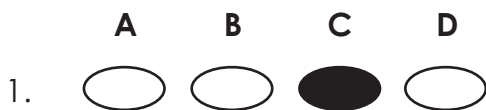

If you need to change your answer, put a cross through the incorrect answer and shade the correct one like this:

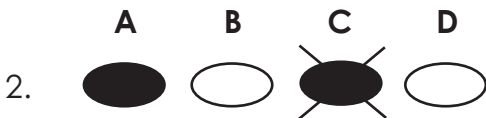

Please do **NOT** use a horizontal line or vertical line. The oval needs to be shaded.

Some of the questions are **free response**. For these questions you will need to write your answer in special answer boxes. Be careful to make sure that you write clearly and inside the boxes.

Maths questions

For maths, you will need to write only ONE number in each box like this:



If you make a mistake and need to change your answer, put a cross through the incorrect answer and write the correct answer above like this:

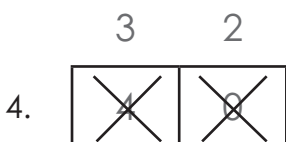

English questions

For English, you will need to write only ONE letter in each box. If there are three empty answer boxes, this means that there are three missing letters. You need to put a letter in each box. You must write clearly in capital letters like this:



Information for Tests

At the start of each section, you will be given instructions that explain what you need to do. Mark your answers carefully, using a black pen.

You must answer the questions on the separate answer sheet.

DO NOT WRITE YOUR ANSWERS IN THE QUESTION BOOKLET.

Test Instructions

In the real test, the instructions before, during and after all parts of the test will be given via a voice recording. Before you begin, you will be asked to check that you can hear the voice recording clearly. Many of the instructions are also written on the question paper. You should raise your hand if you have any questions at any point.

When you are completing a section of the test, you **can**:

- Look back at instructions.
- Go back to any questions within that section.
- Change your answer on the answer sheet within the section you are working.
- Use any spare time to check your answers in the section you are working.

When you are completing a section, you **cannot**:

- Look at any other section.
- Go back to answer or correct answers from another section.
- Look at any future sections.

Exam 'Top Tips'

- **Listen carefully** – to any explanations or instructions you are given.
- **Work accurately** – you may have optional answers, so choose the most reasonable answer if you don't know for sure.
- **Move on if stuck** – if you are stuck on a question, move on. Remember, you need to complete enough questions to score well.
- **Read questions carefully** – including instructions on how to answer questions.
- **Work speedily** – often the biggest challenge in the exam is completing enough questions to gain top marks.
- **Don't stop!** – use all the time you are given. If you finish before the time is up, use this time to check your answers are accurate.

Results Page

After completing and marking each interim test or mock paper, record your score in the table below.

Test	Content Covered	Score
Interim Test 1 Maths	Place Value, Factors & Multiples, Function Machines, Decimals, Conversion & Measurement, Fractions	
Interim Test 1 English	Comprehension, Commas, Hyphens, Parentheses & Dashes, Nouns, Verbs & Tenses, Plurals, Missing Letters	
Interim Test 1 Writing	Creative Writing	
Interim Test 2 Maths	Perimeter & Area, Number Squares, Percentages, Interpreting Data, Mean, Median, Mode & Range, Problem Solving, 3D Shapes	
Interim Test 2 English	Comprehension, Homophones, Colons, Semicolons & Apostrophes, Spelling Tricky Words, Missing Letters	
Interim Test 2 Writing	Creative Writing	
Interim Test 3 Maths	Volume & Capacity, Probability, Ratio, Sequences, Special Numbers, Symmetry, 2D Shapes, Transformations, Equations & Algebra	
Interim Test 3 English	Comprehension, Silent Letters, Metaphors & Personification, Subject & Object, Sentences, Phrases & Clauses, Pronouns, Prepositions & Conjunctions, Adverbs, Adverbials & Modal Verbs, Missing Letters, Missing Sentences	
Interim Test 3 Writing	Creative Writing	
Mock A Paper 1	English Test	
Mock A Paper 2	Creative Writing Test	
Mock A Paper 3	Maths Test	
Mock B Paper 1	English Test	
Mock B Paper 2	Creative Writing Test	
Mock B Paper 3	Maths Test	



INTERIM TEST 1 – MATHS

Section 1: Multiple Choice

Instructions

Read each question carefully.

Answer by shading one of the ovals **A–D** on your answer sheet.

There is only **one** correct answer.

Shade only **one** oval for each question.

You have **20 minutes** to complete this test.

Section 1: Multiple Choice

1. What is the numeral for twenty-two thousand, six hundred and fifty-four?

- A 2,654
- B 220,654
- C 22,654
- D 226,054

2. What is the value of 8 in 78,321?

- A 8
- B 800
- C 8,000
- D 80,000

Section 1: Multiple Choice

3. What is $\frac{28}{84}$ in its simplest form?

- A $\frac{1}{3}$
- B $\frac{4}{12}$
- C $\frac{7}{28}$
- D $1\frac{1}{4}$

4. What is $3\frac{1}{7}$ as a mixed number?

- A $4\frac{2}{7}$
- B $3\frac{6}{7}$
- C $5\frac{1}{7}$
- D $4\frac{3}{7}$

5. A pair of trainers costs £56. A special offer means you can buy a second pair of trainers for $\frac{3}{7}$ of the original cost. How much does the second pair of trainers cost?

- A £48
- B £24
- C £32
- D £16

6. Choose the correct number to make the subtraction work.

$$3\frac{1}{2} - \boxed{} = 2\frac{1}{4}$$

- A $1\frac{1}{4}$
- B $1\frac{1}{2}$
- C $\frac{4}{16}$
- D $\frac{8}{12}$

Section 1: Multiple Choice

7. Choose the correct number to make the subtraction work.

$$4 \frac{7}{8} - \boxed{} = 3 \frac{2}{3}$$

- A $\frac{7}{9}$
 - B $1 \frac{3}{12}$
 - C $1 \frac{1}{12}$
 - D $1 \frac{5}{24}$
-

8. Which decimal has the lowest value?

- A 0.078
 - B 0.378
 - C 3.078
 - D 0.387
-

9. Calculate: $2.31 \times 7 =$

- A 1.617
 - B 161.7
 - C 16.17
 - D 1.17
-

10. I have two bags of sweets. One bag weighs 63.28g and the other bag weighs 52.65g. What is the difference in weight of the two bags of sweets?

- A 10.36g
 - B 10.58g
 - C 10.65g
 - D 10.63g
-

Section 2: Free Response

Instructions

Read each question carefully.

Write your answers on your answer sheet by writing **one** number in each box.

Section 2: Free Response

11. Convert 2,549 grams into kilograms.

12. Alex ran 890cm. How far did they run in metres?

13. Complete the function machine below.

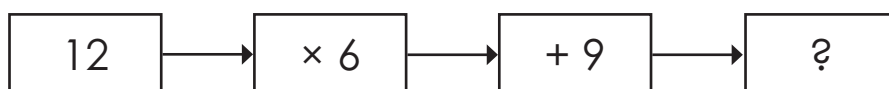

14. Complete the function machine below.

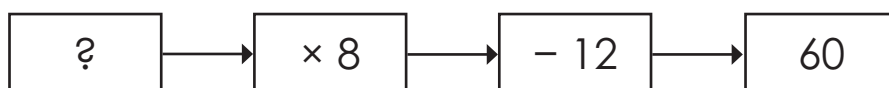

Section 2: Free Response

15. Find an input number to give the required output.

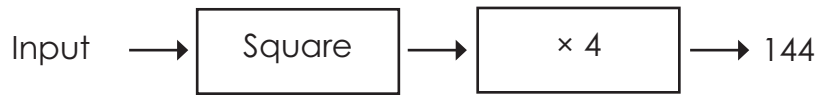

16. Find an input number to give the required output.

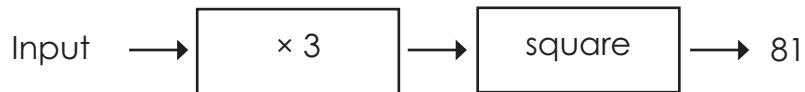

17. Here is a list of factors of 24: 1, 2, 4, 6, 8, 12, 24.
Which factor is missing?

18. What is the lowest common multiple of 6 and 9?

19. What is the highest common factor of 12 and 18?

20. Tom and Emma have been collecting stickers, and they now each have the same number of stickers. Tom has sorted his into packs of 8, and Emma has sorted hers into packs of 12. What is the smallest number of stickers they could each have?



INTERIM TEST 1 – ENGLISH

Instructions

Read each question carefully.

Shade only **one** oval for each question.

You have **20 minutes** to complete this test.

The Old Gentleman

Here in the deep silence of the sleeping country the only things that went by were the trains. They seemed to be all that was left to link the children to the old life that had once been theirs.

5 Straight down the hill in front of Three Chimneys the daily passage of their six feet began to mark a path across the crisp, short turf. They began to know the hours when certain trains passed, and they gave names to them. The 9.15 up was called the Green Dragon. The 10.7 down was the Worm of Wantley. The midnight town express, whose shrieking rush they sometimes woke from their dreams to hear, was the Fearsome Fly-by-night. Peter got up once, in chill starshine, and, peeping at it through his curtains, named it on the spot.

10 It was by the Green Dragon that the old gentleman travelled. He was a very nice looking old gentleman, and he looked as if he were nice, too, which is not at all the same thing. He had a fresh-coloured, clean-shaven face and white hair, and he wore rather oddshaped collars and a top-hat that wasn't exactly the same kind as other people's. Of course the children didn't see all this at first. In fact the first thing they noticed about the old gentleman was his hand.

15 It was one morning as they sat on the fence waiting for the Green Dragon, which was three and a quarter minutes late by Peter's Waterbury watch that had been given him on his last birthday.

"The Green Dragon's going where Father is," said Phyllis; "if it were a really real dragon, we could stop it and ask it to take our love to Father."
"Dragons don't carry people's love," said Peter; "they'd be above it."
20 "Yes, they do, if you tame them thoroughly first. They fetch and carry like pet spaniels," said Phyllis, "and feed out of your hand. I wonder why Father never writes to us."

"Mother says he's been too busy," said Bobbie; "but he'll write soon, she says." "I say," Phyllis suggested, "let's all wave to the Green Dragon as it goes by. If it's a magic dragon, it'll understand and take our love to Father. And if it isn't, three waves aren't much. We shall never miss them."

25 So when the Green Dragon tore shrieking out of the mouth of its dark lair, which was the tunnel, all three children stood on the railing and waved their pocket-handkerchiefs without stopping to think whether they were clean handkerchiefs or the reverse. They were, as a matter of fact, very much the reverse.

And out of a first-class carriage a hand waved back. A quite clean hand. It held a newspaper. It was the old gentleman's hand.

Comprehension

1. What does the author suggest is the only link left to the children's old life?

- A countryside
 - B trains
 - C the old gentleman
 - D Green Dragon
-

2. What is the main subject of the second paragraph?

- A It is about the arrival and departure times of the trains.
 - B It is about the noise of the trains passing.
 - C It is about the names the children gave the trains.
 - D It is about the number of trains that visit the station.
-

3. Where did the children stand to watch the trains arrive and leave the station?

- A On the fence at the side of the railway tracks.
 - B At the top of the hill.
 - C On the platform next to the waiting room.
 - D From a window.
-

4. What was the first thing the children noticed about the old gentleman in the third paragraph? (Line 13)

- A His hand.
- B He travelled on the Green Dragon.
- C He looked as if he were nice.
- D He wore odd-shaped collars and a top hat.

5.

'It was one morning as they sat on the fence' (Line 14).

In the sentence above, which word is the verb?

- A was
- B one
- C morning
- D sat

6.

Why do the children seem most interested in the Green Dragon?

- A It makes a fantastic noise as it leaves the tunnel.
- B It is the train that the old gentleman travels on.
- C It travels to where their father is.
- D The passengers wave to them as it leaves the station.

7.

Which word is closest in meaning to 'reverse' in line 27?

- A Go backward
- B Opposite
- C Upturn
- D Change

Spelling, Grammar & Punctuation

8.

Choose the correct plural for the word in brackets.

The friends visited six _____ (**country**) as they travelled through Europe.

- A countrys
- B countryes
- C country
- D countries

9.

Choose the correct plural for the word in brackets.

The _____ (**child**) explored the museum on their school trip.

- A childron
- B childs
- C children
- D child

10.

Choose the correct plural for the word in brackets.

The long-dormant _____ (**volcano**) have recently shown signs of erupting.

- A volcano
- B volcanoes
- C volcanos
- D volcanes

11. Look for a punctuation mistake in the sentence. Select the group of words with the mistake.

Thomas (the man who worked at the station hadn't seen the missing ticket.

A	B	C	D
----------	----------	----------	----------

12. Look for a punctuation mistake in the sentence. Select the group of words with the mistake.

Quick we must set off for the airport immediately.

A	B	C	D
----------	----------	----------	----------

13. Look for a punctuation mistake in the sentence. Select the group of words with the mistake.

Mum asked us to buy eggs, milk, bread tomatoes and chicken.

A	B	C	D
----------	----------	----------	----------

14. Choose the most appropriate word to complete the passage.

The Sydney Opera House is a world-renowned building found in Sydney, Australia. It is a place where famous shows and concerts take place. It is _____ on Bennelong Point directly next to the harbour, so it boasts fantastic views.

- A** location
- B** locater
- C** locate
- D** located

15. Choose the most appropriate word to complete the passage.

Maggie Aderin-Pocock is a British space scientist and science _____. Her acclaimed work has ranged from making novel, bespoke, scientific instruments including hand-held land mine detectors and optical sub-systems for spacecraft, to co-hosting the BBC mainstay astronomy programme, The Sky at Night.

- A educator
- B teaches
- C education
- D teach

Missing Letters

16. A hospital is a place where people go to get medical **tr--tm--t**.

17. The **m--nt--n** range was covered in snow.

18. He was known for his polite and **c---t--us** manner.

19. She wore a **b---t-ful** bracelet on her wrist.

20. The old house had an eerie and mysterious **atmos-----**.



INTERIM TEST 1 – WRITING

Creative Writing

Instructions

You should spend **10 minutes** planning your answer.

Use the space in this question booklet to make rough notes and plan your answer. This will **NOT** be marked.

You must **NOT** write on your answer sheet during this planning time.

You will be told when your planning time has finished and you can start writing your answer.

You should spend **30 minutes** writing your answer.

Write your answer on the separate answer sheet.

There is no additional paper, so please keep your answer to two sides only.

ONLY the answer sheet will be marked.

Creative Writing

Question

Write a story about a memorable trip.

You could consider:

- making sure you write an exciting story.
- having a beginning, middle and end.
- describing the trip that was taken and why it was memorable.
- introducing some characters.
- how the characters interact.
- how are the characters feeling.
- what the characters learn on the trip.

You may use the space below and on the next page to plan your answer.

You must **NOT** write on your answer sheet during this planning time.

Use this section to plan your story

Answer Page

A series of 20 horizontal dotted lines providing space for writing answers.

Answer Page

A series of 20 horizontal dotted lines for writing answers.

INTERIM 1 ANSWER SHEET

Maths – Multiple Choice

Questions

A B C D

- 1.
- 2.
- 3.
- 4.
- 5.
- 6.
- 7.
- 8.
- 9.
- 10.

Maths – Free Response

Questions

- 11.

	.			
--	---	--	--	--

 kg
- 12.

	.	
--	---	--

 m
- 13.

--	--
- 14.

--
- 15.

--
- 16.

--
- 17.

--
- 18.

--	--
- 19.

--
- 20.

--	--

INTERIM 1 ANSWER SHEET – ENGLISH

Questions

A B C D

- 1.
- 2.
- 3.
- 4.
- 5.
- 6.
- 7.
- 8.

Questions

A B C D

- 9.
- 10.
- 11.
- 12.
- 13.
- 14.
- 15.

16.

T	R			T	M			T
---	---	--	--	---	---	--	--	---

17.

M			N	T			N
---	--	--	---	---	--	--	---

18.

C				T			U	S
---	--	--	--	---	--	--	---	---

19.

B				T		F	U	L
---	--	--	--	---	--	---	---	---

20.

A	T	M	O	S					
---	---	---	---	---	--	--	--	--	--



SELF REFLECTION

Take some time to reflect on your review test experience. Although they may sometimes feel stressful, exams can also be valuable learning opportunities.

Your preparation

How confident did you feel going into the exam?



Did you prepare / revise for the test in any way?

Your performance

Did you understand and follow the instructions given for the exam?

<input type="checkbox"/>	<input type="checkbox"/>
yes	no

Did you have enough time to answer all the questions in the exam?

<input type="checkbox"/>	<input type="checkbox"/>
yes	no

Which topics were you most confident answering?

Which topics were you least confident answering?

What emotions did you feel during the exam?

What might you do differently next time?

In preparation for your next exam, write down one thing you will keep doing and one thing you will change for next time.

Keep	Change



INTERIM TEST 2 – MATHS

Section 1: Multiple Choice

Instructions

Read each question carefully.

Answer by shading one of the ovals **A–D** on your answer sheet.

There is only **one** correct answer.

Shade only **one** oval for each question.

You have **20 minutes** to complete this test.

Section 1: Multiple Choice

1. What is 0.47 as a percentage?

- A 0.47%
- B 47%
- C 4.7%
- D 470%

2. What is 30% of 340?

- A 34
- B 68
- C 102
- D 98

Section 1: Multiple Choice

3.

A clothes shop has a mid-season sale. A coat costing £45 has a 20% discount. What is the discounted price of the coat in £?

- A £36
- B £9
- C £38.50
- D £4.50

4.

In a number square, each row, column and diagonal must add up to the same total. Which number should be in place of the question mark?

?		7
13	9	5
	1	

- A 9
- B 15
- C 5
- D 3

5.

In a number square, each row, column and diagonal must add up to the same total. Which number should be in place of the question mark?

26	5	
	17	23
?		8

- A 20
- B 14
- C 11
- D 19

Section 1: Multiple Choice

6.

In a number square, each row, column and diagonal must add up to the same total. Which number should be in place of the question mark?

6	27	
21	?	
18		

- A 36
- B 15
- C 20
- D 30

7.

A school asked all their students to vote for their favourite sport. The bar chart below shows the results.

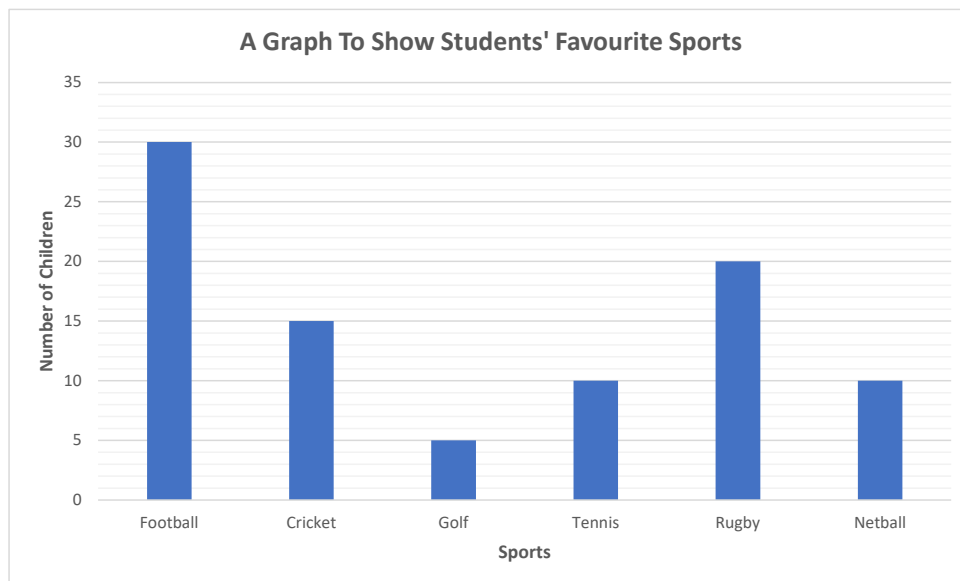

How many students are in the school?

- A 105
- B 70
- C 98
- D 90

Section 1: Multiple Choice

8. How many more children voted for rugby than tennis?

- A 5
 - B 20
 - C 10
 - D 25
-

9. Which two sports received the same number of votes?

- A football & rugby
 - B cricket & tennis
 - C tennis & netball
 - D cricket & netball
-

10. What is the mean of the data below?

14, 8, 7, 18, 23

- A 14
 - B 70
 - C 17
 - D 47
-

Section 2: Free Response

Instructions

Read each question carefully.

Write your answers on your answer sheet by writing **one** number in each box.

Section 2: Free Response

11. What is the range of the data below?

50, 45, 39, 52, 65, 48, 33, 58, 52

12. Anisa has recorded how long she spent revising for her exams each day after school. Here is a record of time spent revising:

Monday	Tuesday	Wednesday	Thursday	Friday
80 minutes	120 minutes	45 minutes	100 minutes	95 minutes

What is the median amount of time she spent revising in minutes?

13. Fence panels are 1.5 metres wide. The perimeter of the garden is 45 metres. How many panels are needed to put a fence around the garden?

14. Jessica needs to send 15 letters. A stamp costs £0.75. She only has £6. How many letters is she unable to send?

15. Each luggage compartment on the train takes 12 suitcases. Today there are 80 suitcases on the train. How many compartments will be full?

Section 2: Free Response

16. Sally has 48 stickers. She gives $\frac{1}{4}$ of her stickers to her friend Tom and then divides the remaining stickers equally among her three younger siblings. How many stickers does each sibling receive?

17. In a school competition, there are 80 students participating. Each student is either on the Red Team or the Blue Team. The Red Team has 12 more members than the Blue Team. How many students are on the Red Team?

18. How many edges does a square-based pyramid have?

19. How many vertices does a square-based pyramid have?

20. How many faces does a cylinder have?



INTERIM TEST 2 – ENGLISH

Instructions

Read each question carefully.

Shade only **one** oval for each question.

You have **20 minutes** to complete this test.

I Wandered Lonely as a Cloud by William Wordsworth

I wandered lonely as a cloud
That floats on high o'er vales and hills,
When all at once I saw a crowd,
A host, of golden daffodils;

- 5 Beside the lake, beneath the trees,
Fluttering and dancing in the breeze.

Continuous as the stars that shine
And twinkle on the milky way,
They stretched in never-ending line

- 10 Along the margin of a bay:
Ten thousand saw I at a glance,
Tossing their heads in sprightly dance.

The waves beside them danced; but they
Out-did the sparkling waves in glee:

- 15 A poet could not but be gay,
In such a jocund company:
I gazed – and gazed – but little thought
What wealth the show to me had brought:

For oft, when on my couch I lie

- 20 In vacant or in pensive mood,
They flash upon that inward eye
Which is the bliss of solitude;
And then my heart with pleasure fills,

Section 1: Comprehension

1. What word in the first stanza tells you there are a lot of daffodils?

- A floats
- B high
- C vales
- D host

2. Why does the speaker compare himself to a cloud in the first line?

- A Because he is lost.
- B Because he is happy.
- C Because he is lonely.
- D Because he is sad.

3. Choose the word that is a synonym of 'wandered'.

- A thought
- B strolled
- C remain
- D settle

4. What is being compared to the stars in the sky in stanza 2?

- A the milky way
- B the never-ending line
- C the bay
- D the daffodils

5.

'Tossing their heads in sprightly dance' (line 12)

What literary device is this an example of?

- A simile
- B metaphor
- C personification
- D hyperbole

6.

Using the context of the poem, choose the word that best defines the word 'jocund'. (Line 16)

- A cheerful
- B pensive
- C curious
- D admiration

7.

What is the significance of the phrase 'inward eye' in the fourth stanza?

- A It refers to the speaker's imagination.
- B It refers to the daffodils' beauty.
- C It refers to the speaker's physical eyes.
- D It refers to the speaker analysing a daffodil.

Spelling, Grammar & Punctuation

8. Find the group of words with the spelling mistake in it.

I guarante that you'll love this product or you'll get your money back!

A	B	C	D
----------	----------	----------	----------

9. Find the group of words with the spelling mistake in it.

We tried to get tickets, but unfortunatley they were already sold out.

A	B	C	D
----------	----------	----------	----------

10. Find the group of words with the spelling mistake in it.

You will receive a discount if you spend over £50.

A	B	C	D
----------	----------	----------	----------

11. Look for a punctuation mistake in the sentence. Select the group of words with the mistake.

The two brothers toy cars were lost in the garden.

A	B	C	D
----------	----------	----------	----------

12. Look for a punctuation mistake in the sentence. Select the group of words with the mistake.

I have lived in a range of places Madrid, Rome and Manchester.

A	B	C	D
----------	----------	----------	----------

13.

Choose the correct homophone to complete the sentence.

I stood in _____ of their courage and determination.

- A or
- B awe
- C oar
- D oare

14.

Choose the correct homophone to complete the sentence.

The _____ of the flowers was very strong and made me sneeze.

- A scent
- B sent
- C cent
- D sente

15.

Choose the correct homophone to complete the sentence.

The doctor advised rest to give the injury time to _____.

- A he'll
- B heel
- C heal
- D heale

Missing Letters

16. In **an---nt** times, people used clay tools to make pottery.

17. I visited the **li----y** to borrow my favourite book.

18. The **s----tist** made an important and exciting discovery.

19. The **expl--at--n** was very helpful for understanding the concept.

20. The **--em--al** reaction created bubbles and steam.



INTERIM TEST 2 – WRITING

Creative Writing

Instructions

You should spend **10 minutes** planning your answer.

Use the space in this question booklet to make rough notes and plan your answer. This will **NOT** be marked.

You must **NOT** write on your answer sheet during this planning time.

You will be told when your planning time has finished and you can start writing your answer.

You should spend **30 minutes** writing your answer.

Write your answer on the separate answer sheet.

There is no additional paper, so please keep your answer to two sides only.

ONLY the answer sheet will be marked.

Creative Writing

Question

Write a story about perseverance. Your title should be: 'Perseverance'.

You could consider:

- making sure you write an exciting story.
- having a beginning, middle and end.
- describing who showed perseverance and why it is important to your story.
- introducing some characters.
- how the characters interact.
- how are the characters feeling.
- what the characters learn from persevering.

You may use the space below and on the next page to plan your answer.

You must **NOT** write on your answer sheet during this planning time.

Use this section to plan your story

Answer Page

A series of 25 horizontal dotted lines for writing answers.

Maths – Multiple Choice

Questions

	A	B	C	D
1.	<input type="radio"/>	<input type="radio"/>	<input type="radio"/>	<input type="radio"/>
2.	<input type="radio"/>	<input type="radio"/>	<input type="radio"/>	<input type="radio"/>
3.	<input type="radio"/>	<input type="radio"/>	<input type="radio"/>	<input type="radio"/>
4.	<input type="radio"/>	<input type="radio"/>	<input type="radio"/>	<input type="radio"/>
5.	<input type="radio"/>	<input type="radio"/>	<input type="radio"/>	<input type="radio"/>
6.	<input type="radio"/>	<input type="radio"/>	<input type="radio"/>	<input type="radio"/>
7.	<input type="radio"/>	<input type="radio"/>	<input type="radio"/>	<input type="radio"/>
8.	<input type="radio"/>	<input type="radio"/>	<input type="radio"/>	<input type="radio"/>
9.	<input type="radio"/>	<input type="radio"/>	<input type="radio"/>	<input type="radio"/>
10.	<input type="radio"/>	<input type="radio"/>	<input type="radio"/>	<input type="radio"/>

Maths – Free Response

Questions

11.	<input type="text"/>	<input type="text"/>
12.	<input type="text"/>	<input type="text"/>
13.	<input type="text"/>	<input type="text"/>
14.	<input type="text"/>	
15.	<input type="text"/>	
16.	<input type="text"/>	<input type="text"/>
17.	<input type="text"/>	<input type="text"/>
18.	<input type="text"/>	
19.	<input type="text"/>	
20.	<input type="text"/>	

INTERIM 2 ANSWER SHEET – ENGLISH

Questions

A B C D

- 1.
- 2.
- 3.
- 4.
- 5.
- 6.
- 7.
- 8.

Questions

A B C D

- 9.
- 10.
- 11.
- 12.
- 13.
- 14.
- 15.

16.

A	N				N	T
----------	----------	--	--	--	----------	----------

17.

L	I					Y
----------	----------	--	--	--	--	----------

18.

S					T	I	S	T
----------	--	--	--	--	----------	----------	----------	----------

19.

E	X	P	L			A	T			N
----------	----------	----------	----------	--	--	----------	----------	--	--	----------

20.

		E	M			A	L
--	--	----------	----------	--	--	----------	----------



SELF REFLECTION

Take some time to reflect on your review test experience. Although they may sometimes feel stressful, exams can also be valuable learning opportunities.

Your preparation

How confident did you feel going into the exam?



Did you prepare / revise for the test in any way?

Your performance

Did you understand and follow the instructions given for the exam?

<input type="checkbox"/>	<input type="checkbox"/>
yes	no

Did you have enough time to answer all the questions in the exam?

<input type="checkbox"/>	<input type="checkbox"/>
yes	no

Which topics were you most confident answering?

Which topics were you least confident answering?

What emotions did you feel during the exam?

What might you do differently next time?

In preparation for your next exam, write down one thing you will keep doing and one thing you will change for next time.

Keep	Change



INTERIM TEST 3 – MATHS

Section 1: Multiple Choice

Instructions

Read each question carefully.

Answer by shading one of the ovals **A–D** on your answer sheet.

There is only **one** correct answer.

Shade only **one** oval for each question.

You have **20 minutes** to complete this test.

Section 1: Multiple Choice

1. A jug contains 1.5 litres of juice. If you pour out 650 millilitres, how much juice is left in the jug?

- A 1.15 litres
- B 1 litre
- C 0.65 litres
- D 0.85 litres

2. The volume of a rectangular box is 240 cm^3 . Its length is 8cm and its width is 5cm. What is the height of the box?

- A 5cm
- B 6cm
- C 7cm
- D 8cm

Section 1: Multiple Choice

3. What is the volume of the cuboid below?

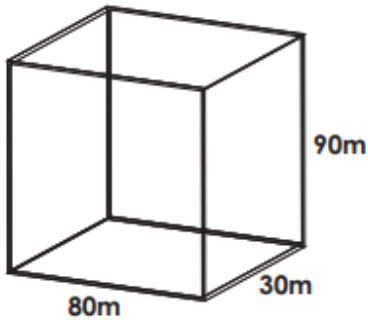

- A 216,000m³
- B 22,600m³
- C 162,000m³
- D 218,000m³
-
4. The ratio of red balls to blue balls in a ball pit is 9:4. If there are 20 blue balls, how many red balls will there be?

- A 36
- B 80
- C 50
- D 45

5. Imagine a classroom in which each student either completely believes or does not believe at all in the existence of a teapot orbiting around the Sun between Mars and Jupiter, and where the proportion of believers is $\frac{3}{7}$. Write the ratio of teapot believers to teapot non-believers in this classroom.

- A 4:3
- B 2:4
- C 3:4
- D 3:7

Section 1: Multiple Choice

6. What is the probability you will pick a hearts card from a deck of 52 cards, in its simplest form?

- A $\frac{1}{8}$
 - B $\frac{1}{4}$
 - C $\frac{39}{52}$
 - D $\frac{2}{4}$
-

7. There are 30 people in a cafe. 10 are children and the others are adults. One person is going to receive a free drink. What is the probability of an adult receiving the free drink?

- A $\frac{2}{3}$
 - B $\frac{1}{4}$
 - C $\frac{5}{6}$
 - D $\frac{2}{10}$
-

8. Which of these is the next triangular number: **1, 3, 6, 10, 15, 21, ?**

- A 28
 - B 26
 - C 36
 - D 40
-

9. What is the next number in this sequence: **4, 9, 19, 39, 79, ?**

- A 157
 - B 159
 - C 162
 - D 164
-

10. What is the next number in this sequence: $1 \frac{1}{2}$, $2 \frac{1}{4}$, 3 , $3 \frac{3}{4}$, $4 \frac{1}{2}$, ?

A $5 \frac{1}{4}$

B $5 \frac{1}{2}$

C $5 \frac{3}{4}$

D 6

Section 2: Free Response

Instructions

Read each question carefully.

Write your answers on your answer sheet by writing **one** number in each box.

Section 2: Free Response

11. The radius of this circle is 46mm. What is the length of AB in mm?

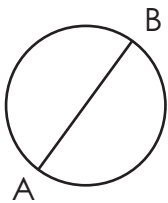

12. One of the angles in a right-angled triangle is 64° . What is the size of the smallest angle in degrees?

13. What is the order of rotational symmetry of the shape below?

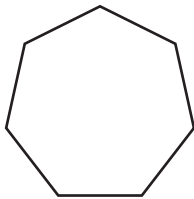

14. What is 9^2 ?

15. What is 4^3 ?

Section 2: Free Response

16. Triangle ABC is translated three squares down and two squares left. What are the coordinates of the new position of A?

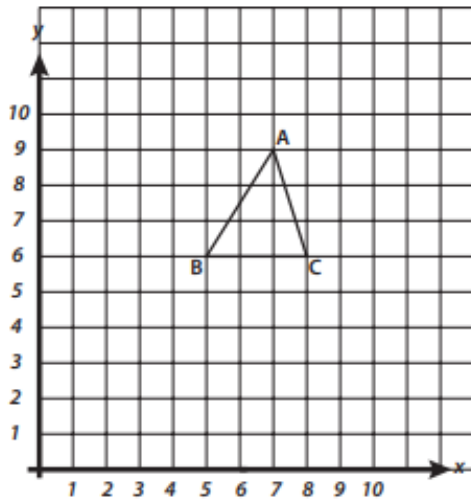

17. If $a = 6$, $b = 5$ and $c = 2$
 $(4a - 3b) + 7c =$

18. If $a = 9$, $b = 4$ and $c = 3$
 $(b^3 + 8c) - 3a =$

19. If $a = 13$, $b = 18$ and $c = 8$
 $(8a - c^2) + 5b =$

20. If $a = 3$, $b = 2$ and $c = 8$
 $(12a \times 3b) - 8c =$



INTERIM TEST 3 – ENGLISH

Instructions

Read each question carefully.

Shade only **one** oval for each question.

You have **20 minutes** to complete this test.

The Incredible Machine

Everyone has a favourite attraction at an amusement park, and I am no different. However, unlike most people, who seem to prefer roller coasters, my favourite ride is a little more gentle. Every time I go to an amusement park, I absolutely have to ride the Ferris wheel.

5 The Ferris wheel is simple and yet also quite complex. That is, riding it is easy, but how it works is complicated. A series of carts are attached to a wheel, which is attached to a rim. That rim rotates vertically around an axis, and gravity keeps the carts upright. As simple as the ride seems, only advanced engineers can make Ferris wheels that are both safe and fun.

What it Lacks in Thrills...

10 While the Ferris wheel is not as thrilling as a roller coaster, it is still very exciting. The fact of being high in the air makes it so much more entertaining than a lot of rides. I mean, how often do you hang that high up in daily life?

Nevertheless, I have to admit, I don't seek Ferris wheels out because of their excitement. Rather, I find them very relaxing. At the top of the Ferris wheel you get beautiful sights of the park. You also get a sense of calm that you don't get in the hustle and bustle of the park below.

It Happened at the World's Fair

15 The first Ferris wheel was made by and named after George Washington Gale Ferris, Jr. He designed it for the Chicago World's Fair in 1893. It was the tallest attraction there, standing 264 feet high.

20 However, visitors to the fair were impressed by the size of the ride, as well as the mechanics of it. In 1893, anything that was not turned by hand was considered a sight to see. And the wheel, which was a machine, was truly incredible to see. Furthermore, as one visitor put it, the wheel was amazing because it seemed to be missing support. That is, it did not look like it could stand on its own. And yet it did and even rotated!

They Keep Reaching Higher and Higher

Ferris wheel technology has only improved since then. Most of today's Ferris wheels are much larger than that first one. The largest in the world is the Singapore Flyer, which stands slightly more than twice as tall as George Ferris's wheel.

25 Today, the Ferris wheel is the most common amusement park ride. But that does not mean you should take them for granted. Instead, be thankful for Ferris's invention. The next time you're at an amusement park, don't just look up at the impressive wheel in the sky on your way to a newer attraction, take it for a spin!

Section 1: Comprehension

1. Choose a synonym for the word 'attraction'. (Line 1)

- A sense
 - B park
 - C ride
 - D vision
-

2. Choose the best antonym for the word 'complex'. (Line 4)

- A impressive
 - B intricate
 - C beautiful
 - D simple
-

3. What does the author like best about Ferris wheels?

- A The impressive engineering and beauty of them.
 - B The excitement and thrills they guarantee.
 - C The beautiful sights and relaxation they allow.
 - D They were designed as much to be seen as to be ridden.
-

4. The passage was most likely written to:

- A Explain the history of Ferris wheels and why the author likes them.
- B Describe the author's favourite amusement park rides.
- C Explain the original design of Ferris wheels and how they work today.
- D Describe the history of Ferris wheels and why they are so popular.

5. Using the information in the passage, the tallest Ferris wheel in the world is:

- A Under 250 feet tall.
- B Between 250 and 400 feet tall.
- C Between 250 and 500 feet tall.
- D Between 500 and 750 feet tall.

6. What does the heading: '**They Keep Reaching Higher and Higher**' suggest?

- A That Ferris wheels have technology within them to make them grow.
- B That Ferris wheels may be even taller in the future as technology improves.
- C That Ferris wheels are the tallest structures in the world.
- D That children can now reach the top of Ferris wheels.

7. What does the author advise you to do at the end of the passage?

- A Ride the Ferris wheel next time you visit an amusement park.
- B Invest in technology to improve Ferris wheels.
- C Visit the tallest Ferris wheel in the world.
- D Avoid amusement parks that have a Ferris wheel.

Spelling, Grammar & Punctuation

8. The word below has a silent letter in it. Choose the silent letter.

scenery

A s

B c

C e

D r

9. The word below has a silent letter in it. Choose the silent letter.

design

A e

B s

C i

D g

10. Which literary device is used in the sentence below?

He is a shining star.

A simile

B metaphor

C personification

D idiom

11. Which literary device is used in the sentence below?

The light danced on the surface of the water.

- A simile
- B metaphor
- C personification
- D idiom

12. Which literary device is used in the sentence below?

The sky was as dark as coal.

- A simile
- B metaphor
- C personification
- D idiom

13. Identify the part of the sentence that contains the **object**.

Joe played his first game of rugby since breaking his arm.

A	B	C	D
---	---	---	---

14. Identify the part of the sentence that contains the **subordinate clause**.

On sports day Freddie won a medal for the race although he didn't win.

A	B	C	D
---	---	---	---

15. Identify the part of the sentence that contains the **adverbial**.

Bobbi eats toast and jam for their breakfast every day.

A	B	C	D
----------	----------	----------	----------

16. Identify the part of the sentence that contains the **relative pronoun**.

Can you take me to gymnastics, which is in the next village?

A	B	C	D
----------	----------	----------	----------

Missing Sentences

17. Select the correct sentence to complete the short text so that it makes sense.

Jackson was excited about his school play.

MISSING SENTENCE

As he stood backstage, his heart was racing with excitement and some nerves. The stage curtain lifted, and Jackson lept onto the stage.

- A** He decided to stay at home and watch television instead.
- B** He packed his script and costume in his rucksack.
- C** He slept through his alarm and woke up late.
- D** Jackson decided to play basketball for two hours.

18. Select the correct sentence to complete the short text so that it makes sense.

The market was always the highlight of the Christmas season.

MISSING SENTENCE

Families ran from stall to stall, browsing the gifts and delicious food.

As night fell, everyone gathered to watch the firework display.

- A** Heavy snow spoiled the event and it was cancelled.
- B** The market was cancelled due to a power cut.
- C** This year the market square was used as a car park instead.
- D** Colourful lights, and the smell of hot dogs filled the streets of the town.

19. Select the correct sentence to complete the short text so that it makes sense.

The school trip to the zoo was eagerly anticipated.

There was a buzz of excitement as children boarded the bus for the trip.

MISSING SENTENCE

They couldn't stop talking about the way the funny penguins waddled on the ice.

- A** The students gazed in wonder as the big cats stretched lazily in the sun.
- B** The bus broke down on the way to the zoo.
- C** The zoo was closed because an animal had escaped.
- D** All the children were locked outside.

20. Select the correct sentence to complete the short text so that it makes sense.

Mr Louca's garden pond was a haven for wildlife.

MISSING SENTENCE

Small fish darted beneath the surface, their quick movements rippling the water.

It was his favourite spot to enjoy a peaceful and relaxing morning coffee.

- A** The pond had dried up in the hot summer.
- B** Lily pads floated gently on the water, their round leaves creating tiny islands.
- C** The pond was heavily polluted with household waste.
- D** Mr Louca filled his pond to build a pizza oven.

Missing Letters

21. Her mum encouraged her to **p---e---e** even though the task was difficult.

22. The **s--n--y** from the mountain was breathtaking and worth the long hike.

23. He felt a sense of **re-----** after finishing his challenging homework.

24. The weather **f----ast** predicted rain for the whole week.

25. She was grateful for all the help she **re-----ed** with her charity work.



INTERIM TEST 3 – WRITING

Creative Writing

Instructions

You should spend **10 minutes** planning your answer.

Use the space in this question booklet to make rough notes and plan your answer. This will **NOT** be marked.

You must **NOT** write on your answer sheet during this planning time.

You will be told when your planning time has finished and you can start writing your answer.

You should spend **30 minutes** writing your answer.

Write your answer on the separate answer sheet.

There is no additional paper, so please keep your answer to two sides only.

ONLY the answer sheet will be marked.

Creative Writing

Question

Write a story based on this picture below.



You could consider:

- making sure you write an exciting story.
- having a beginning, middle and end.
- introducing some characters.
- how the characters interact.
- how are the characters feeling.

You may use the space below and on the next page to plan your answer.

You must **NOT** write on your answer sheet during this planning time.

Use this section to plan your story

Answer Page

A series of 21 horizontal dotted lines for writing answers.

Answer Page

A series of 25 horizontal dotted lines for writing answers.

INTERIM 3 ANSWER SHEET

Maths – Multiple Choice

Questions

A **B** **C** **D**

1.
2.
3.
4.
5.
6.
7.
8.
9.
10.

Maths – Free Response

Questions

11. mm
12. °
13.
14.
15.
16. (,)
17.
18.
19.
20.

INTERIM 3 ANSWER SHEET – ENGLISH

Questions

A B C D

- 1.
- 2.
- 3.
- 4.
- 5.
- 6.
- 7.
- 8.
- 9.
- 10.

Questions

A B C D

- 11.
- 12.
- 13.
- 14.
- 15.
- 16.
- 17.
- 18.
- 19.
- 20.

INTERIM 3 ANSWER SHEET – ENGLISH

21.

P				E				E
---	--	--	--	---	--	--	--	---

22.

S			N			Y
---	--	--	---	--	--	---

23.

R	E				
---	---	--	--	--	--

24.

F					A	S	T
---	--	--	--	--	---	---	---

25.

R	E					E	D
---	---	--	--	--	--	---	---



SELF REFLECTION

Take some time to reflect on your review test experience. Although they may sometimes feel stressful, exams can also be valuable learning opportunities.

Your preparation

How confident did you feel going into the exam?



Did you prepare / revise for the test in any way?

Your performance

Did you understand and follow the instructions given for the exam?

<input type="checkbox"/>	<input type="checkbox"/>
yes	no

Did you have enough time to answer all the questions in the exam?

<input type="checkbox"/>	<input type="checkbox"/>
yes	no

Which topics were you most confident answering?

Which topics were you least confident answering?

What emotions did you feel during the exam?

What might you do differently next time?

In preparation for your next exam, write down one thing you will keep doing and one thing you will change for next time.

Keep	Change

**FSCE STYLE
Entrance Test
for Entry into Year 7
MOCK A PAPER 1**

YEAR 7 MOCK ENTRANCE TEST FOR SCHOOLS

Name:

Primary School:

Test Date:

40 minutes

Each section is timed separately.

Read the instructions at the start of each section.

You must NOT open this booklet until you are told to do so.

Section 1: Comprehension

Instructions

Carefully read the text, then answer the questions that follow.

Select the **best** answer by shading one of the ovals **A–D** on your answer sheet.

There is only **one** correct answer for each question.

Shade only **one** oval for each question.

Example

The forest was alive with the sounds of birds chirping and leaves rustling in the gentle breeze. Sunlight streamed through the canopy, casting dappled shadows on the ground below. Mya walked quietly along the narrow path, careful not to disturb the peace. She was on the lookout for rare butterflies to add to her collection, hoping that today she might spot the elusive blue morpho, a butterfly known for its shimmering, blue wings. As she ventured deeper into the forest, she felt a thrill of excitement mixed with a touch of nervousness.

i Why was Mia walking quietly along the path?

- A** She was trying to catch birds.
- B** She wanted to avoid getting lost.
- C** She didn't want to disturb the peace.
- D** She was scared of other animals.

The correct answer is **C**. C has been marked on your answer sheet.

ii What was special about the butterfly Mia hoped to find?

- A** It had bright red wings.
- B** It was very small.
- C** It could make sounds.
- D** It had shimmering blue wings.

The correct answer is **D**. D has been marked on your answer sheet.

You have 20 minutes for this section. There are 20 questions to answer.

Schools' Step-By-Step Guide to Fairtrade

Fairtrade is a way of buying and selling products that help make the world a better place. It is a system that ensures that the people who produce the products we buy are treated fairly. It started in the 1960s when people became concerned about the way farmers and workers were being treated in developing countries. Fairtrade helps these farmers and workers get a fair price for their products, so they can have better working conditions and a better life for themselves and their families. When a product is labelled as 'Fairtrade', it means that the farmers or workers who produced it were paid a fair price for their work. This price is determined by the Fairtrade organisation, and it takes into account the cost of living in that country. Fairtrade also ensures that the workers have safe working conditions and that they are not being exploited. According to the Fairtrade Foundation's annual report for 2019–2020, sales of Fairtrade products in the UK reached £1.7 billion, representing a 20% increase from the previous year. We've made a great start towards a better trade system for farmers in the developing world. But we've still got a long way to go, and we need more people to come with us in making the small steps towards a fairer world.

The World's Biggest Fairtrade Breakfast

Did you know that your breakfast has travelled a long way before it reaches your plate? Every year, people all over the world come together to celebrate Fairtrade by participating in the 'World's Biggest Fairtrade Breakfast'. This event is a way for people to enjoy a delicious breakfast while supporting Fairtrade products. By participating in this event, people can show their support for Fairtrade and help raise awareness about the importance of fair trade practices. World Fair Trade Day is the annual celebration for the whole Fairtrade movement internationally and is held on the second Saturday in May every year. We will be taking part in the World's Biggest Fairtrade Breakfast and we hope you will too! Start your day of Fairtrade as soon as you get up, with as many Fairtrade products as possible for breakfast! You could include products such as Fairtrade certified coffee, tea, sugar, juice, jams, chocolate spread and honey.

Fairtrade in School

Fairtrade is not only important for farmers and workers in developing countries but also for students like you! Many schools across the world have become Fairtrade schools, which means they have made a commitment to support Fairtrade products. By supporting Fairtrade in schools, students can help promote fairness, social responsibility and sustainable farming practices. School uniforms are a requirement for many students around the world, but have you ever thought about where they come from? By choosing to buy Fairtrade school uniforms, we can ensure that the cotton used to make them was produced in a fair and sustainable way. Cotton is one of the most widely traded commodities in the world, but cotton farmers often face challenges in getting a fair price for their products. Many cotton farmers live in developing countries and approximately 75% live in poverty. Fairtrade helps cotton farmers to reduce their environmental impact and increase their yields. Due to the high demand for Fairtrade cotton, its cultivation uses about 50% of all chemical pesticides used in agriculture.

Some schools have even made a commitment to use Fairtrade uniforms, helping to create a more socially responsible and sustainable learning environment for students. School uniforms with Fairtrade cotton are now in many stores. But we can do more:

- Make a display about the difference Fairtrade makes to the lives of producers. Put it somewhere prominent so students, staff, parents / carers and visitors can see it.
- Ask your local uniform shop or retailer to stock Fairtrade cotton uniforms.
- Show them your school is interested in Fairtrade. You could do this with letters, a visit or even a presentation, to explain to them what Fairtrade means and how important it is to you.

Now answer these questions.

Section 1: Comprehension

1. What is Fairtrade?

- A A type of clothing brand.
 - B A sustainable farming practice.
 - C A movement promoting ethical trade.
 - D A type of coffee.
-

2. From what you have read, who does Fairtrade benefit?

- A Shopkeepers
 - B Farmers in poor countries
 - C Factory owners
 - D Schools
-

3. When did Fairtrade start?

- A 1940s
 - B 1950s
 - C 1960s
 - D 1970s
-

4. According to the text, what does the Fairtrade organisation take into account when determining price?

- A Cost of living in that country.
- B How many farmers produce in that country.
- C How ethical farmers' processes have been.
- D The demand for the product they are pricing.

5.

According to the Fairtrade Foundation's annual report for 2019–2020, sales of Fairtrade products in the UK reached £1.7 billion. What percentage increase was this on the previous year?

- A 5%
- B 10%
- C 15%
- D 20%

6.

What is meant by 'your breakfast has travelled a long way before it reached your plate'? (Line 14)

- A You live a long way from the supermarket.
- B Your dining room is a long way from the fridge.
- C The food is produced by farmers in developing countries miles away.
- D Your supermarket home delivery takes a long time to arrive.

7.

When is World Fair Trade Day?

- A The second Saturday in May every year.
- B Every Tuesday in May.
- C The 5th of every month.
- D The third Monday in March every year.

8.

Which of these products is not listed in the text as being available under the Fairtrade mark?

- A coffee
- B tea
- C sugar
- D flour

9.

Which material is described as 'one of the most widely traded commodities in the world'?

- A silk
 - B cotton
 - C chocolate
 - D coffee
-

10.

How does Fairtrade help cotton farmers?

- A By ensuring they have enough chemical pesticides.
 - B By ensuring they receive a fair price for their cotton.
 - C By ensuring they can participate in World Fairtrade Day.
 - D By ensuring they can continue to increase the price of cotton.
-

11.

Use the context of the text to choose the most suitable definition for 'commodity'? (Line 31)

- A material
 - B cotton
 - C farmer
 - D production
-

12.

What percentage of cotton farmers live in poverty?

- A 50%
- B 75%
- C 25%
- D 10%

-
- 13.** What does the term 'sustainable farming practices' mean?
- A** Farming practices that are harmful to the environment.
 - B** Farming practices that are not economically viable.
 - C** Farming practices that meet the needs of the present without compromising the ability of future generations to meet their own needs.
 - D** Farming practices that are not compatible with modern technology.
-

- 14.** Which of these is not a step the article recommends that schools take to encourage buying Fairtrade cotton?
- A** Make a display about Fairtrade.
 - B** Force all parents / carers to buy only Fairtrade uniforms.
 - C** Give a presentation on Fairtrade.
 - D** Ask local uniform shops to stock Fairtrade cotton uniforms.
-

- 15.** What type of writing is this extract?
- A** Fiction
 - B** Autobiography
 - C** Fairy tale
 - D** Informative text
-

- 16.** Which of these words is a synonym for 'annual'? (Line 19)
- A** yearly
 - B** weekly
 - C** daily
 - D** monthly

17. Use the context of the text to choose the best definition for 'yields'. (Line 34)

- A revenue
- B crops
- C produce
- D money

18. In the context of the extract, which of the words below is the closest synonym for 'cultivate'?

- A grow
- B picked
- C consumed
- D sold

19. What is meant by 'put it somewhere prominent'? (Line 40)

- A Put it somewhere high up.
- B Make the font large.
- C Make it brightly coloured.
- D Put it somewhere lots of people will see.

20. Who is the text written for?

- A businesses
- B schools
- C after-school clubs
- D adults

Section 2: Vocabulary

Instructions

Read the word in the question box. What does it mean? Which one of the answer options A–E means the same, or nearly the same, as the word in the question?

Answer by shading one of the ovals A–E on your answer sheet.

Find the best answer for each question.

There is only one correct answer. Shade only one oval for each question.

Example

i

abundant

A	B	C	D	E
rare	plentiful	empty	insufficient	scarce

The correct answer is **B**, plentiful.

B has been shaded on your answer sheet.

You have **5 minutes** for this section.

There are **15 questions** to answer.

Section 2: Vocabulary

1 **conceal**

A	B	C	D	E
hide	show	reveal	expose	illuminate

2 **glimpse**

A	B	C	D	E
stare	ignore	peak	gaze	glance

3 **fragile**

A	B	C	D	E
sturdy	weak	rough	soft	durable

4 **reluctant**

A	B	C	D	E
keen	eager	hesitant	determined	willing

5 **adjacent**

A	B	C	D	E
nearby	opposite	far	remote	detached

6 **commence**

A	B	C	D	E
pause	end	begin	cease	stop

7 seldom

A	B	C	D	E
often	never	rarely	sometimes	constantly

8 vivid

A	B	C	D	E
dull	faint	bright	pale	subdued

9 precise

A	B	C	D	E
vague	exact	loose	rough	inaccurate

10 sustain

A	B	C	D	E
weaken	break	support	abandon	ruin

11 blissful

A	B	C	D	E
sad	anxious	indifferent	joyful	angry

12 imitate

A	B	C	D	E
create	mimic	ignore	forget	abandon

13 eliminate

A	B	C	D	E
remove	add	save	grow	include

14 generous

A	B	C	D	E
giving	abrupt	greedy	envious	selfish

15 impartial

A	B	C	D	E
biased	unfair	favourable	neutral	prejudiced

Section 3: Missing Letters

Instructions

Carefully read the sentences below. Some words have missing letters.

Fill in the missing letters to complete the words so that each sentence makes sense.

Choose the **best** answer to complete each word. There is only **one** correct answer for each question.

Complete the words on your answer sheet by writing **one** letter in each box.

Answer using CAPITAL LETTERS.

Example

i

An **astro-----** studies the stars and planets.

The correct word is astronomer.

The missing letters NOMER have been written on your answer sheet.

You have **10 minutes** for this section.

There are **20 questions** to answer.

Section 3: Missing Letters

1 The gardener watered the **b---ue-** of roses on the patio.

2 With great determination, she **pra-----ed** the piano every day.

3 His kindness and **-ene-----ty** were admired by everyone who knew him.

4 The family enjoyed the **l----rely** walk through the park on Sunday.

5 The cake was so **de--c-----** that everyone asked for a second piece.

6 The student worked hard to **mem-----** the vocabulary list.

7 She felt a little **a--w--d** during her first day at the new school.

8 The fireworks display was a truly **sp--t---lar** sight in the night sky.

9 The crowd watched as the **a--l---** sprinted to the finish line.

10 The artist used **v-b---t** colors to bring her painting to life.

11 She looked around the museum with a sense of **CU---s--y** and wonder.

12 The meal at the restaurant was **e---is--e** but very expensive.

13 The teacher asked the class to be **a---n--ve** during the lesson.

14 The explorer needed a **CO-----** to find his way through the forest.

15 The noisy **comm-----** in the hallway made it hard to concentrate.

16 She felt a **SU---** of excitement as her team scored the winning goal.

17 The puppy was **ex----ted** after a day of running in the garden.

18 She found the long story **int----ing** and couldn't put the book down.

19 It was **ne--s--ry** for them to pack extra clothes for the camping trip.

20 The knight wore **ar---r** to protect himself in battle.

ANSWER SHEET – Mock A Paper 1

English – Comprehension

Questions

	A	B	C	D
1.	<input type="radio"/>	<input type="radio"/>	<input type="radio"/>	<input type="radio"/>
2.	<input type="radio"/>	<input type="radio"/>	<input type="radio"/>	<input type="radio"/>
3.	<input type="radio"/>	<input type="radio"/>	<input type="radio"/>	<input type="radio"/>
4.	<input type="radio"/>	<input type="radio"/>	<input type="radio"/>	<input type="radio"/>
5.	<input type="radio"/>	<input type="radio"/>	<input type="radio"/>	<input type="radio"/>
6.	<input type="radio"/>	<input type="radio"/>	<input type="radio"/>	<input type="radio"/>
7.	<input type="radio"/>	<input type="radio"/>	<input type="radio"/>	<input type="radio"/>
8.	<input type="radio"/>	<input type="radio"/>	<input type="radio"/>	<input type="radio"/>
9.	<input type="radio"/>	<input type="radio"/>	<input type="radio"/>	<input type="radio"/>
10.	<input type="radio"/>	<input type="radio"/>	<input type="radio"/>	<input type="radio"/>

Questions

	A	B	C	D
11.	<input type="radio"/>	<input type="radio"/>	<input type="radio"/>	<input type="radio"/>
12.	<input type="radio"/>	<input type="radio"/>	<input type="radio"/>	<input type="radio"/>
13.	<input type="radio"/>	<input type="radio"/>	<input type="radio"/>	<input type="radio"/>
14.	<input type="radio"/>	<input type="radio"/>	<input type="radio"/>	<input type="radio"/>
15.	<input type="radio"/>	<input type="radio"/>	<input type="radio"/>	<input type="radio"/>
16.	<input type="radio"/>	<input type="radio"/>	<input type="radio"/>	<input type="radio"/>
17.	<input type="radio"/>	<input type="radio"/>	<input type="radio"/>	<input type="radio"/>
18.	<input type="radio"/>	<input type="radio"/>	<input type="radio"/>	<input type="radio"/>
19.	<input type="radio"/>	<input type="radio"/>	<input type="radio"/>	<input type="radio"/>
20.	<input type="radio"/>	<input type="radio"/>	<input type="radio"/>	<input type="radio"/>

English – Vocabulary

Questions

	A	B	C	D	E
1.	<input type="radio"/>	<input type="radio"/>	<input type="radio"/>	<input type="radio"/>	<input type="radio"/>
2.	<input type="radio"/>	<input type="radio"/>	<input type="radio"/>	<input type="radio"/>	<input type="radio"/>
3.	<input type="radio"/>	<input type="radio"/>	<input type="radio"/>	<input type="radio"/>	<input type="radio"/>
4.	<input type="radio"/>	<input type="radio"/>	<input type="radio"/>	<input type="radio"/>	<input type="radio"/>
5.	<input type="radio"/>	<input type="radio"/>	<input type="radio"/>	<input type="radio"/>	<input type="radio"/>
6.	<input type="radio"/>	<input type="radio"/>	<input type="radio"/>	<input type="radio"/>	<input type="radio"/>
7.	<input type="radio"/>	<input type="radio"/>	<input type="radio"/>	<input type="radio"/>	<input type="radio"/>
8.	<input type="radio"/>	<input type="radio"/>	<input type="radio"/>	<input type="radio"/>	<input type="radio"/>

Questions

	A	B	C	D	E
9.	<input type="radio"/>	<input type="radio"/>	<input type="radio"/>	<input type="radio"/>	<input type="radio"/>
10.	<input type="radio"/>	<input type="radio"/>	<input type="radio"/>	<input type="radio"/>	<input type="radio"/>
11.	<input type="radio"/>	<input type="radio"/>	<input type="radio"/>	<input type="radio"/>	<input type="radio"/>
12.	<input type="radio"/>	<input type="radio"/>	<input type="radio"/>	<input type="radio"/>	<input type="radio"/>
13.	<input type="radio"/>	<input type="radio"/>	<input type="radio"/>	<input type="radio"/>	<input type="radio"/>
14.	<input type="radio"/>	<input type="radio"/>	<input type="radio"/>	<input type="radio"/>	<input type="radio"/>
15.	<input type="radio"/>	<input type="radio"/>	<input type="radio"/>	<input type="radio"/>	<input type="radio"/>

ANSWER SHEET – Mock A Paper 1

English – Missing Letters

1.

B				U	E	
---	--	--	--	---	---	--

2.

P	R	A					E	D
---	---	---	--	--	--	--	---	---

3.

	E	N	E					T	Y
--	---	---	---	--	--	--	--	---	---

4.

L					R	E	L	Y
---	--	--	--	--	---	---	---	---

5.

D	E			C				
---	---	--	--	---	--	--	--	--

6.

M	E	M					
---	---	---	--	--	--	--	--

7.

A			W			D
---	--	--	---	--	--	---

8.

S			C	T				L	A	R
---	--	--	---	---	--	--	--	---	---	---

9.

A			L			
---	--	--	---	--	--	--

10.

V		B				T
---	--	---	--	--	--	---

ANSWER SHEET – Mock A Paper 1

11.

C	U				S			Y
---	---	--	--	--	---	--	--	---

12.

E				I	S			E
---	--	--	--	---	---	--	--	---

13.

A				N			V	E
---	--	--	--	---	--	--	---	---

14.

C	O					
---	---	--	--	--	--	--

15.

C	O	M	M					
---	---	---	---	--	--	--	--	--

16.

S	U			
---	---	--	--	--

17.

E	X					T	E	D
---	---	--	--	--	--	---	---	---

18.

I	N	T					I	N	G
---	---	---	--	--	--	--	---	---	---

19.

N	E			S			R	Y
---	---	--	--	---	--	--	---	---

20.

A	R				R
---	---	--	--	--	---

**FSCE STYLE
Entrance Test
for Entry into Year 7**

MOCK A PAPER 2

YEAR 7 MOCK ENTRANCE TEST FOR SCHOOLS

Name:

Primary School:

Test Date:

40 minutes

You must NOT open this booklet until you are told to do so.

Creative Writing

Instructions

You should spend **10 minutes** planning your answer.

Use the space in this question booklet to make rough notes and plan your answer. This will **NOT** be marked.

You must **NOT** write on your answer sheet during this planning time.

You will be told when your planning time has finished and you can start writing your answer.

You should spend **30 minutes** writing your answer.

Write your answer on the separate answer sheet.

There is no additional paper, so please keep your answer to two sides only.

ONLY the answer sheet will be marked.

Creative Writing

Question

Write a story based on the theme of discovery. Your title should be: 'Discovery'.

You could consider:

- making sure you write an exciting story.
- having a beginning, middle and end.
- describing what was discovered and why it is important to your story.
- introducing some characters.
- how the characters interact.
- how are the characters feeling.
- what the characters learn from the discovery.

You may use the space below and on the next page to plan your answer.

You must **NOT** write on your answer sheet during this planning time.

Use this section to plan your story

Creative Writing

FSCE STYLE
Entrance Test
for Entry into Year 7

MOCK A PAPER 3

YEAR 7 MOCK ENTRANCE TEST FOR SCHOOLS

Name:

Primary School:

Test Date:

40 minutes

Each section is timed separately.
Read the instructions at the start of each section.

You must NOT open this booklet until you are told to do so.

Section 1: Multiple Choice

Instructions

Read each question carefully.

You can use the space after each question for working out, but you will not get any marks for your working out.

Answer by shading one of the ovals **A–D** on your answer sheet.

There is only **one** correct answer.

Shade only **one** oval for each question.

Example

i

What is the value of 8 in 8,739?

- A 8
- B 80
- C 800
- D 8,000

The correct answer is **D**.

D has been shaded on your answer sheet.

You have **20 minutes** for this section.

There are **25 questions** to answer.

Section 1: Multiple Choice

1. Mr Wiggin's supermarket bill is £22.38. At the checkout the bill is reduced by £1.77 by using a voucher. What is the new amount he has to pay?

- A £24.15
- B £22.16
- C £20.61
- D £24.51

2. Which number is divisible by both 6 and 9?

- A 6
- B 16
- C 18
- D 24

3. Look at this thermometer. What temperature does the arrow point to in Celsius?

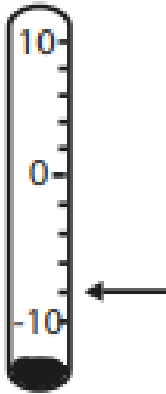

- A 12°
- B -8°
- C 9°
- D -9°

Section 1: Multiple Choice

4. On Tuesday night at 7pm there were 167 people in the Olympiad Sports Hall. 102 people came by car. The rest walked or got the bus. How many walked or got the bus in total?

- A 270
 - B 67
 - C 102
 - D 65
-

5. Light bulbs cost 79p each. How much will 6 light bulbs cost?

- A 69p
 - B £4.74
 - C £2.37
 - D £4.47
-

6. Which of the letters below has 2 lines of symmetry?

- A S
 - B A
 - C T
 - D X
-

7. Laura is decorating cupcakes. She needs 36 chocolate sprinkles per cupcake. How many sprinkles does she need for 100 cupcakes?

- A 3,600
 - B 36,000
 - C 360
 - D 7,200
-

Section 1: Multiple Choice

8. The local library is moving into a new building. Each packing box holds 80 books. They have 780 books in the non-fiction section. How many boxes will they need?

- A 9
 - B 10
 - C 11
 - D 70
-

9. Chandni has one £2 coin, two £1 coins, three 50 pence coins, four 5 pence coins and three pennies. How much money does she have altogether?

- A £5.73
 - B £7.73
 - C £6.20
 - D £5.93
-

10. What is the numeral for eight hundred and seventy-two thousand?

- A 872,000
 - B 87,200
 - C 8,720
 - D 8,720,000
-

11. What is 4^3 equivalent to?

- A 4×3
- B $3 \times 3 \times 3 \times 3$
- C $4 \times 4 \times 4$
- D $4 \times 3 \times 3$

Section 1: Multiple Choice

12. At a pie-eating contest, each of the 9 contestants ate $\frac{1}{3}$ of a huge pie each. How many pies were eaten in total?

- A 1
- B 2
- C 3
- D 5

13. Complete the sequence: 12, 24, ____, 48, 60, 72.

- A 28
- B 30
- C 34
- D 36

14. As part of a school's safety campaign, children in a class were asked how they got to school.

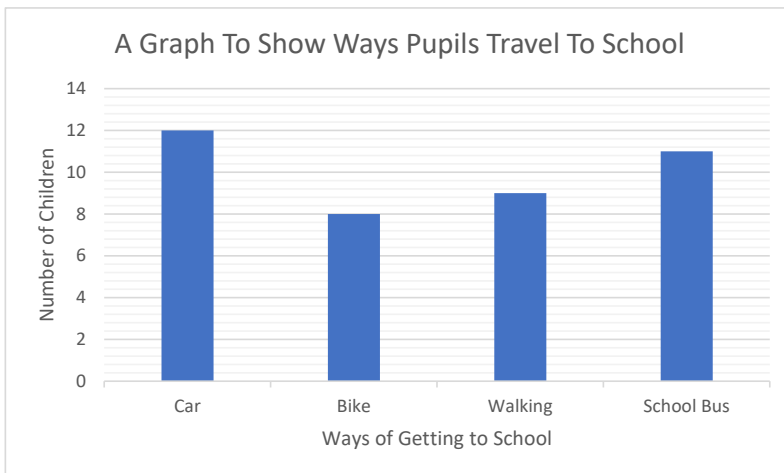

How many children got the school bus?

- A 12
- B 8
- C 11
- D 9

Section 1: Multiple Choice

15. What was the total number of children surveyed?

- A 40
- B 32
- C 38
- D 43

16. When surveyed the following year, double the amount of children walked to school. How many children is that?

- A 16
- B 18
- C 19
- D 15

17. When every box is filled in on this grid, each row, each column and each diagonal adds up to 15. Which number should be in the box with the question mark?

2	9	4
	1	?

- A 5
- B 8
- C 7
- D 11

Section 1: Multiple Choice

18. Give the coordinates of point A on the grid below

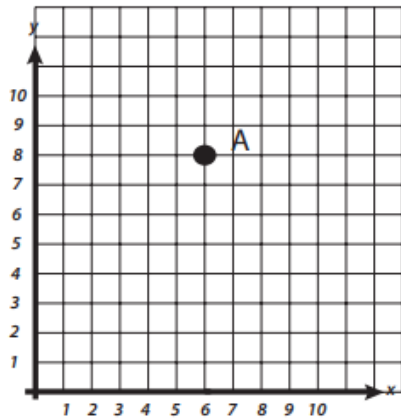

- A (5,7)
- B (6,6)
- C (6,8)
- D (8,6)
19. What number is shown on the number line below?

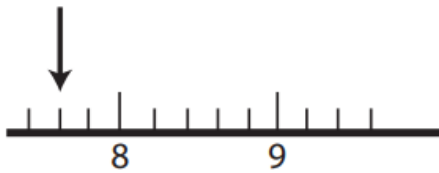

- A 7.8
- B 7.3
- C 8.6
- D 7.6

Section 1: Multiple Choice

20. These are the months of the year:

January

February

March

April

May

June

July

August

September

October

November

December

What fraction of the months end with the letter Y?

A $\frac{1}{3}$

B $\frac{1}{2}$

C $\frac{1}{5}$

D $\frac{1}{6}$

21. What is 24,472 rounded to the nearest hundred?

A 24500

B 24000

C 25000

D 24400

22. Calculate:

$$16 + (9 \times 12) \div 4$$

A 24

B 32.5

C 31

D 28

Section 1: Multiple Choice

23. 200 families visit an adventure park. $\frac{2}{5}$ of them pay by card. How many families is that?

- A 120
- B 40
- C 100
- D 80

24. What is the perimeter of the shape below?

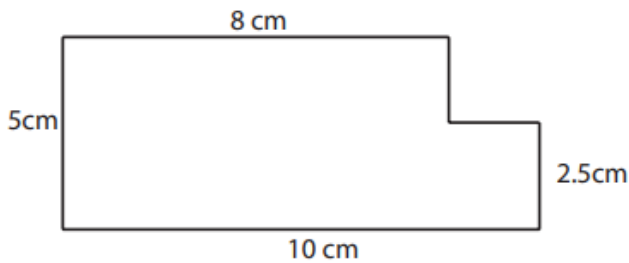

- A 25.5cm
- B 28cm
- C 30cm
- D 36cm

25. What is the area of the shape above?

- A 45cm^2
- B 30cm^2
- C 40cm^2
- D 45cm^2

Section 2: Free Response

Instructions

Read each question carefully.

You can use the space after each question for working out, but you will not get any marks for your working out.

Write your answers on your answer sheet by writing **one** number in each box.

Example

i

How many minutes are there in two days?

The correct answer is **2,880 minutes**.

This has been marked on your answer sheet.

You have **20 minutes** for this section.

There are **20 questions** to answer.

Section 2: Free Response

1. Complete the function machine below.

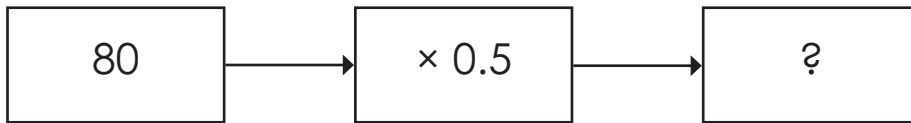

2. How many edges does a cube have?

3. Find an input number to give the required output.

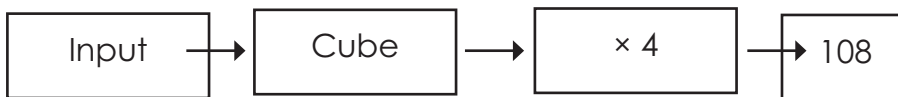

4. Solve the equation: $5x + y = z$ $z = 110$ $y = 10$ $x = ?$

5. Solve the equation: $5x + y = z$ $z = 110$ $y = 10$ $x = ?$

6. What is the area of the whole shape below?

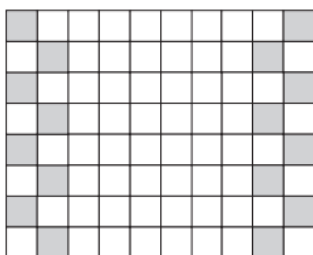

Section 2: Free Response

7. What percentage of the shape in question 6 is shaded grey?

8. The product of two numbers is 44. The difference between the two numbers is 20. What are the two numbers?

9. The table below shows the number of miles covered each day on a walking tour of the Scottish Highlands.

Day	Number of miles
Mon	?
Tues	6
Wed	6
Thurs	5
Fri	6
Sat	4
Sun	3

The mean is 5. The mode is 6. How many miles did they walk on Monday?

10. Complete the following equation.

$$25 \times 5 - 20 = 10 \times y + 5 \quad y =$$

11. Below are the results of a group in a science test.

77%	45%	66%	75%	90%	81%	69%	88%
-----	-----	-----	-----	-----	-----	-----	-----

What is the range of the results shown?

Section 2: Free Response

12. If the pass mark for the group above is 70%, what fraction of the group passed the test?

13. Cups cost £2.25 and spoons cost £0.50. How much will Jasleen need to pay altogether to get 8 of each?

14. The temperature yesterday lunchtime was 4°C . Last night at its coldest point the temperature had fallen by 11°C . What was the lowest temperature last night?

15. There are 640 scouts in the town of Gwentle. $\frac{5}{8}$ of the scouts have camped out at night. How many of the scouts haven't?

16. A bus due to arrive at 10:20a.m. is 14 minutes late on Monday. The bus arrives a further 14 minutes late per day. What time does the bus arrive on Friday?

17. If you are facing NE and you turn 90° clockwise, in which direction are you facing now?

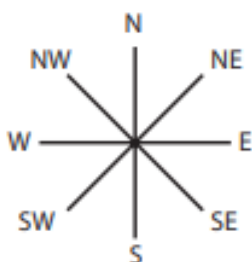

18. What is the square root of 64?

Section 2: Free Response

19.

The parallelogram below has two angles marked. If x measures 125° , what is the size of angle y ?

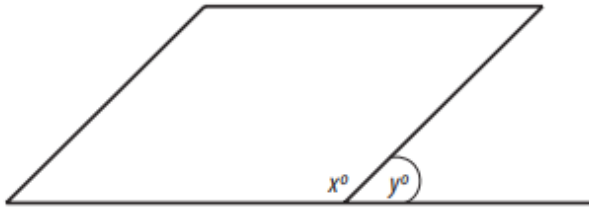

20.

Calculate

$$48.6 \div 3.6 =$$

ANSWER SHEET – Mock A Paper 3

Maths – Multiple Choice

Questions

A B C D

- 1.
- 2.
- 3.
- 4.
- 5.
- 6.
- 7.
- 8.
- 9.
- 10.
- 11.
- 12.
- 13.
- 14.
- 15.

Questions

A B C D

- 16.
- 17.
- 18.
- 19.
- 20.
- 21.
- 22.
- 23.
- 24.
- 25.

ANSWER SHEET – Mock A Paper 3

Maths – Free Response

1.

--	--

2.

--	--

 edges

3.

--	--

4.

--

5.

--	--

6.

--	--

 cm²

7.

--	--

 %

8.

--

 and

--	--

9.

--

10.

--	--

ANSWER SHEET – Mock A Paper 3

11.

12. /

13. £

14. – °C

15.

16. : am

17.

18.

19. °

20. .



SELF REFLECTION

Take some time to reflect on your review test experience. Although they may sometimes feel stressful, exams can also be valuable learning opportunities.

Your preparation

How confident did you feel going into the exam?



Did you prepare / revise for the test in any way?

Your performance

Did you understand and follow the instructions given for the exam?

<input type="checkbox"/>	<input type="checkbox"/>
yes	no

Did you have enough time to answer all the questions in the exam?

<input type="checkbox"/>	<input type="checkbox"/>
yes	no

Which topics were you most confident answering?

Which topics were you least confident answering?

What emotions did you feel during the exam?

What might you do differently next time?

In preparation for your next exam, write down one thing you will keep doing and one thing you will change for next time.

Keep	Change

**FSCE STYLE
Entrance Test
for Entry into Year 7
MOCK B PAPER 1**

YEAR 7 MOCK ENTRANCE TEST FOR SCHOOLS

Name:

Primary School:

Test Date:

40 minutes

Each section is timed separately.
Read the instructions at the start of each section.

You must NOT open this booklet until you are told to do so.

Section 1: Comprehension

Instructions

Carefully read the text, then answer the questions that follow.

Select the **best** answer by shading one of the ovals **A–D** on your answer sheet.

There is only **one** correct answer for each question.

Shade only **one** oval for each question.

Example

The small boat rocked gently on the lake as Sam cast his fishing line into the water. The early morning mist hung over the surface, giving the lake an eerie, magical quality. Sam loved these quiet moments, watching as the first rays of sunlight peeked over the mountains in the distance. Suddenly, he felt a tug on his line and his heart skipped a beat. He pulled, carefully reeling in what he hoped would be the biggest fish he had ever caught.

i What time of day is it in the story, and how do we know?

- A** It's midday, as suggested by the bright sunlight.
- B** It's afternoon, as suggested by the golden glow on the lake.
- C** It's nighttime, as suggested by the dark, quiet lake.
- D** It's early morning, as suggested by the mist and first rays of sunlight.

The correct answer is **D**. D has been marked on your answer sheet.

ii Why does Sam's heart 'skip a beat'?

- A** He hears a strange noise in the distance.
- B** He feels a tug on his fishing line, hoping it's a big fish.
- C** He sees a bird flying over the lake.
- D** He remembers he forgot his fishing net at home.

The correct answer is **B**. B has been marked on your answer sheet.

You have 20 minutes for this section. There are 20 questions to answer.

Read the extract from *Jo's Boys* by Louisa M. Alcott then answer the questions that follow.

This was the beginning of the summer holiday, and it was curious to see what a pleasant little stir Dan's and Emil's coming made in the quiet life of the studious community; for they seemed to bring a fresh breeze with them that enlivened everyone. Many of the collegians remained during vacation; and Plumfield and Parnassus did their best to make these days
5 pleasant for them, since most came from distant States, were poor, and had few opportunities but this for culture or amusement. Emil was hail-fellow-well-met with men and maids, and went rollicking about in true sailor fashion; but Dan stood rather in awe of the 'fair girl-graduates', and was silent when among them, eyeing them as an eagle might a flock of doves. He got on better with the young men, and was their hero at once. Their
10 admiration for his manly accomplishments did him good; because he felt his educational defects keenly, and often wondered if he could find anything in books to satisfy him as thoroughly as did the lessons he was learning from Nature's splendidly illustrated volume. In spite of his silence, the girls found out his good qualities, and regarded 'the Spaniard', as they named him, with great favour; for his black eyes were more eloquent than his tongue,
15 and the kind creatures tried to show their friendly interests in many charming ways.

He saw this, and endeavoured to be worthy of it—curbing his free speech, toning down his rough manners, and watching the effect of all he said and did, anxious to make a good impression. The social atmosphere warmed his lonely heart, the culture excited him to do his best, and the changes which had taken place during his absence, both in himself and
20 others, made the old home seem like a new world. After the life in California, it was sweet and restful to be here, with these familiar faces round him, helping him to forget much that he regretted, and to resolve to deserve more entirely the confidence of these good fellows, the respect of these innocent girls.

So there was riding, rowing, and picnicking by day, music, dancing, and plays by night;
25 and everyone said there had not been so gay a vacation for years. Bess kept her promise, and let the dust gather on her beloved clay while she went pleasuring with her mates or studied music with her father, who rejoiced over the fresh roses in her cheeks and the laughter which chased away the dreamy look she used to wear. Josie quarrelled less with Ted; for Dan had a way of looking at her which quelled her instantly, and had
30 almost as good an effect upon her rebellious cousin. But Octoo did even more for the lively youth, who found that her charms entirely eclipsed those of the bicycle which had been his heart's delight before. Early and late he rode this untiring beast, and began to gain flesh—to the great joy of his mother, who feared that her beanstalk was growing too fast for health.

35 Demi, finding business dull, solaced his leisure by photographing everybody he could induce to sit or stand to him, producing some excellent pictures among many failures; for he had a pretty taste in grouping, and endless patience. He might be said to view the world through the lens of his camera, and seemed to enjoy himself very much squinting at his fellow beings from under a bit of black cambric. Dan was a treasure to him; for he took
40 well, and willingly posed in his Mexican costume, with horse and hound, and all wanted copies of these effective photographs. Bess, also, was a favourite sitter; and Demi received a prize at the Amateur Photographic Exhibition for one of his cousin with all her hair about her face, which rose from the cloud of white lace draping the shoulders. These were freely handed round by the proud artist; and one copy had a tender little history yet to be told.

Section 1: Comprehension

1. What was the impact of Dan's and Emil's arrival on the community during summer vacation?

- A They brought a sense of calm and tranquillity.
 - B They caused disruption and chaos.
 - C They brought a fresh and lively atmosphere.
 - D They were largely ignored by the community.
-

2. Choose one alternative word for the word 'rejoiced', as used in the context of the text.

- A cried
 - B loving
 - C delighted
 - D devastation
-

3. How did Emil behave among the students during the vacation?

- A He was reserved and silent.
 - B He was rollicking and sociable.
 - C He kept to himself and avoided interactions.
 - D He was indifferent to the others.
-

4. How did Dan feel about the 'fair girl-graduates'?

- A He felt comfortable and chatty among them.
- B He admired them and was silent in their presence.
- C He was dismissive of their presence.
- D He was uncomfortable and shy among them.

5. Why did Dan try to curb his free speech and tone down his rough manners?

- A He was asked to do so by the community.
- B He wanted to make a good impression on the others.
- C He was trying to avoid attention.
- D He was imitating Emil's behaviour.

6. How did the social atmosphere affect Dan?

- A It made him more reserved and distant.
- B It warmed his lonely heart and excited him to do his best.
- C It had no effect on him.
- D It made him regret being there.

7. What hobby did Demi take up during the vacation?

- A painting landscapes
- B playing musical instruments
- C photography
- D horseback riding

8. What is the below quote an example of?

'Plumfield and Parnassus did their best'

- A alliteration
- B an idiom
- C personification
- D a rhetorical question

9. From paragraph three, choose one thing that is said to be done in the day?

- A swimming
- B dancing
- C playing
- D rowing

10. Choose one alternative word for the word 'rebellious', as used in the context of the text.

- A docile
- B submissive
- C defiant
- D pretentious

11. What time of year is this passage set?

- A spring
- B summer
- C autumn
- D winter

12. In the below quote, which word is a proper noun?

'After the life in California, it was sweet and restful to be here...'

- A sweet
- B California
- C here
- D be

-
- 13.** Choose one alternative word for the word 'eclipsed', as used in the context of the text.
- A** outshone
 - B** inshined
 - C** created
 - D** forgotten
-

- 14.** Select the correct meaning of the word 'patience'.
- A** An act of resigning from a job or office.
 - B** Allow oneself to enjoy the pleasure of.
 - C** Having or showing a friendly, generous, and considerate nature.
 - D** The ability to accept delay, suffering, or annoyance without complaining or becoming angry.
-

- 15.** How did the girls view Dan, and what nickname did they give him?
- A** They disliked him, and they called him 'The Outsider'.
 - B** They regarded him with favour, and they named him 'The Spaniard'.
 - C** They found him arrogant, and they called him 'The Lone Wolf'.
 - D** They were indifferent and did not give him a nickname.
-

- 16.** Select the correct meaning of the word 'defects'.
- A** A shortcoming, imperfection or lack.
 - B** A narrow space between two surfaces that have broken or been moved apart.
 - C** An allotted place in an arrangement or scheme.
 - D** Cause (someone) to deviate from an intended purpose.
-

17. For what did Demi receive a prize for at the Amateur Photographic Exhibition?

- A A picture of landscapes.
- B A picture of Josie.
- C A picture of Dan.
- D A picture of Bess.

18. Why was Octoo important to Ted during the vacation?

- A Octoo was Ted's favourite pet.
- B Octoo had a calming influence on Ted.
- C Octoo's charms eclipsed Ted's bicycle.
- D Ted disliked Octoo.

19. What did Josie and Ted quarrel less about during the vacation?

- A Study habits.
- B Dan's arrival.
- C Josie's rebellious nature.
- D Octoo's influence on Ted.

20. Select the correct meaning of the word '**quelled**'.

- A Subdue or silence (someone).
- B Resolve or reach an agreement about (an argument or problem).
- C Fasten (something) securely in a particular place or position.
- D Bring together or into contact so that a real or notional link is established.

Section 2: Vocabulary

Instructions

Read the word in the question box. What does it mean? Which one of the answer options A–E means the same, or nearly the same, as the word in the question?

Answer by shading one of the ovals A–E on your answer sheet.

Find the best answer for each question.

There is only one correct answer. Shade only one oval for each question.

Example

i ancient

A	B	C	D	E
new	broken	old	shiny	beautiful

The correct answer is **C**, old.

C has been shaded on your answer sheet.

You have **5 minutes** for this section.

There are **15 questions** to answer.

Section 2: Vocabulary

1 **brief**

A	B	C	D	E
lengthy	short	dull	strong	slow

2 **diligent**

A	B	C	D	E
lazy	careful	distracted	calm	fast

3 **vivid**

A	B	C	D	E
bright	vague	quiet	strong	dull

4 **cautious**

A	B	C	D	E
careful	curious	confused	quiet	sleepy

5 **sanctimonious**

A	B	C	D	E
silent	sincere	flexible	deviate	smug

6 **tentative**

A	B	C	D	E
talkative	spacious	provisional	experienced	indicate

7 odious

A	B	C	D	E
repulsive	smelly	pleasant	silent	sluggish

8 hostile

A	B	C	D	E
hospitable	kind	unfriendly	generous	selfish

9 delicate

A	B	C	D	E
tough	fragile	distant	noisy	plain

10 apparent

A	B	C	D	E
unclear	invisible	obvious	silent	forgetful

11 commotion

A	B	C	D	E
silence	noise	calm	emptiness	slowness

12 reluctant

A	B	C	D	E
eager	willing	hesitant	cheerful	speedy

13 diligent

A	B	C	D	E
dependable	lazy	distant	conscientious	fortunate

14 risible

A	B	C	D	E
rising	dramatic	useless	washable	laughable

15 pragmatic

A	B	C	D	E
practical	awesome	irresponsible	brave	disorganised

Section 3: Missing Letters

Instructions

Carefully read the sentences below. Some words have missing letters.

Fill in the missing letters to complete the words so that each sentence makes sense.

Choose the **best** answer to complete each word. There is only **one** correct answer for each question.

Complete the words on your answer sheet by writing **one** letter in each box.

Answer using CAPITAL LETTERS.

Example

i

The children watched as the ice melted and turned to **li---d**.

The correct word is liquid.

The missing letters QUI have been written on your answer sheet.

You have **10 minutes** for this section.

There are **20 questions** to answer.

Section 3: Missing Letters

1 The artist used a **u---ue** shade of blue that made the painting stand out.

2 The final answer on the test required careful **-a-c-lat--n**.

3 She wanted to **a--n-wl--ge** the effort he made to help her.

4 Her dancing was **-l-g--t** and graceful.

5 The **d-c--ent--y** about space was both interesting and educational.

6 The writer's work was **-n--i--d** by her travels around the world.

7 The children watched with **f--c--a---n** as the caterpillar became a butterfly.

8 The artist chose a **p--a--e** type of clay, allowing her to mold it easily.

9

The storm caused **d---s---ion** in the coastal village, leaving homes damaged.

10

He showed great **-es---en-e** by bouncing back quickly after his operation.

11

The police officer observed every **s---le** clue left at the crime scene.

12

Her voice was barely **a---ble** over the loud music at the party.

13

The abandoned castle had an **-m--o-s** feeling, especially at dusk.

14

He solved the puzzle with **r--ar--bl-** speed.

15

The children listened **in----ly** to the storyteller, eager to know what happened.

16

The athlete's **s--m--a** allowed her to run long distances without tiring.

17 He felt a sense of **n--t---ia** as he walked through his old neighbourhood.

18 The final performance was **-em---bl-**, leaving the audience in awe.

19 The little girl was fascinated by the colourful fish in the **-q---iu-**.

20 Her idea was **i---v---ve** and inspired others to think creatively.

ANSWER SHEET – Mock B Paper 1

English – Comprehension

Questions

	A	B	C	D
1.	<input type="radio"/>	<input type="radio"/>	<input type="radio"/>	<input type="radio"/>
2.	<input type="radio"/>	<input type="radio"/>	<input type="radio"/>	<input type="radio"/>
3.	<input type="radio"/>	<input type="radio"/>	<input type="radio"/>	<input type="radio"/>
4.	<input type="radio"/>	<input type="radio"/>	<input type="radio"/>	<input type="radio"/>
5.	<input type="radio"/>	<input type="radio"/>	<input type="radio"/>	<input type="radio"/>
6.	<input type="radio"/>	<input type="radio"/>	<input type="radio"/>	<input type="radio"/>
7.	<input type="radio"/>	<input type="radio"/>	<input type="radio"/>	<input type="radio"/>
8.	<input type="radio"/>	<input type="radio"/>	<input type="radio"/>	<input type="radio"/>
9.	<input type="radio"/>	<input type="radio"/>	<input type="radio"/>	<input type="radio"/>
10.	<input type="radio"/>	<input type="radio"/>	<input type="radio"/>	<input type="radio"/>

Questions

	A	B	C	D
11.	<input type="radio"/>	<input type="radio"/>	<input type="radio"/>	<input type="radio"/>
12.	<input type="radio"/>	<input type="radio"/>	<input type="radio"/>	<input type="radio"/>
13.	<input type="radio"/>	<input type="radio"/>	<input type="radio"/>	<input type="radio"/>
14.	<input type="radio"/>	<input type="radio"/>	<input type="radio"/>	<input type="radio"/>
15.	<input type="radio"/>	<input type="radio"/>	<input type="radio"/>	<input type="radio"/>
16.	<input type="radio"/>	<input type="radio"/>	<input type="radio"/>	<input type="radio"/>
17.	<input type="radio"/>	<input type="radio"/>	<input type="radio"/>	<input type="radio"/>
18.	<input type="radio"/>	<input type="radio"/>	<input type="radio"/>	<input type="radio"/>
19.	<input type="radio"/>	<input type="radio"/>	<input type="radio"/>	<input type="radio"/>
20.	<input type="radio"/>	<input type="radio"/>	<input type="radio"/>	<input type="radio"/>

English – Vocabulary

Questions

	A	B	C	D	E
1.	<input type="radio"/>	<input type="radio"/>	<input type="radio"/>	<input type="radio"/>	<input type="radio"/>
2.	<input type="radio"/>	<input type="radio"/>	<input type="radio"/>	<input type="radio"/>	<input type="radio"/>
3.	<input type="radio"/>	<input type="radio"/>	<input type="radio"/>	<input type="radio"/>	<input type="radio"/>
4.	<input type="radio"/>	<input type="radio"/>	<input type="radio"/>	<input type="radio"/>	<input type="radio"/>
5.	<input type="radio"/>	<input type="radio"/>	<input type="radio"/>	<input type="radio"/>	<input type="radio"/>
6.	<input type="radio"/>	<input type="radio"/>	<input type="radio"/>	<input type="radio"/>	<input type="radio"/>
7.	<input type="radio"/>	<input type="radio"/>	<input type="radio"/>	<input type="radio"/>	<input type="radio"/>
8.	<input type="radio"/>	<input type="radio"/>	<input type="radio"/>	<input type="radio"/>	<input type="radio"/>

Questions

	A	B	C	D	E
9.	<input type="radio"/>	<input type="radio"/>	<input type="radio"/>	<input type="radio"/>	<input type="radio"/>
10.	<input type="radio"/>	<input type="radio"/>	<input type="radio"/>	<input type="radio"/>	<input type="radio"/>
11.	<input type="radio"/>	<input type="radio"/>	<input type="radio"/>	<input type="radio"/>	<input type="radio"/>
12.	<input type="radio"/>	<input type="radio"/>	<input type="radio"/>	<input type="radio"/>	<input type="radio"/>
13.	<input type="radio"/>	<input type="radio"/>	<input type="radio"/>	<input type="radio"/>	<input type="radio"/>
14.	<input type="radio"/>	<input type="radio"/>	<input type="radio"/>	<input type="radio"/>	<input type="radio"/>
15.	<input type="radio"/>	<input type="radio"/>	<input type="radio"/>	<input type="radio"/>	<input type="radio"/>

ANSWER SHEET – Mock B Paper 1

English – Missing Letters

1.

U				U	E
---	--	--	--	---	---
2.

	A		C		L	A	T			N
--	---	--	---	--	---	---	---	--	--	---
3.

A			N		W	L			G	E
---	--	--	---	--	---	---	--	--	---	---
4.

	L		G			T
--	---	--	---	--	--	---
5.

D		C			E	N	T			Y
---	--	---	--	--	---	---	---	--	--	---
6.

	N			I			D
--	---	--	--	---	--	--	---
7.

F			C			A				N
---	--	--	---	--	--	---	--	--	--	---
8.

P			A			E
---	--	--	---	--	--	---
9.

D				S				I	O	N
---	--	--	--	---	--	--	--	---	---	---
10.

	E	S				E	N		E
--	---	---	--	--	--	---	---	--	---

ANSWER SHEET – Mock B Paper 1

11.

S				L	E
---	--	--	--	---	---

12.

A				B	L	E
---	--	--	--	---	---	---

13.

	M			O		S
--	---	--	--	---	--	---

14.

R			A	R			B	L	
---	--	--	---	---	--	--	---	---	--

15.

I	N					L	Y
---	---	--	--	--	--	---	---

16.

S			M			A
---	--	--	---	--	--	---

17.

N			T				I	A
---	--	--	---	--	--	--	---	---

18.

	E	M				B	L	
--	---	---	--	--	--	---	---	--

19.

	Q				I	U	
--	---	--	--	--	---	---	--

20.

I				V				V	E
---	--	--	--	---	--	--	--	---	---

**FSCE STYLE
Entrance Test
for Entry into Year 7**

MOCK B PAPER 2

YEAR 7 MOCK ENTRANCE TEST FOR SCHOOLS

Name:

Primary School:

Test Date:

40 minutes

You must NOT open this booklet until you are told to do so.

Creative Writing

Instructions

You should spend **10 minutes** planning your answer.

Use the space in this question booklet to make rough notes and plan your answer. This will **NOT** be marked.

You must **NOT** write on your answer sheet during this planning time.

You will be told when your planning time has finished and you can start writing your answer.

You should spend **30 minutes** writing your answer.

Write your answer on the separate answer sheet.

There is no additional paper, so please keep your answer to two sides only.

ONLY the answer sheet will be marked.

Creative Writing

Question

Write a story about an unexpected hero.

You could consider:

- making sure you write an exciting story.
- having a beginning, middle and end.
- describing who is the hero of the story and why.
- introducing some characters.
- how the characters interact.
- how are the characters feeling.
- what the characters learn from the hero.

You may use the space below and on the next page to plan your answer.

You must **NOT** write on your answer sheet during this planning time.

Use this section to plan your story

Creative Writing

Answer Page

A series of 20 horizontal dotted lines for writing answers.

**FSCE STYLE
Entrance Test
for Entry into Year 7
MOCK B PAPER 3**

YEAR 7 MOCK ENTRANCE TEST FOR SCHOOLS

Name:

Primary School:

Test Date:

40 minutes

Each section is timed separately.
Read the instructions at the start of each section.

You must NOT open this booklet until you are told to do so.

Section 1: Multiple Choice

Instructions

Read each question carefully.

You can use the space after each question for working out, but you will not get any marks for your working out.

Answer by shading one of the ovals **A–D** on your answer sheet.

There is only **one** correct answer.

Shade only **one** oval for each question.

Example

i

How many vertices does a cube have?

A 5

B 6

C 7

D 8

The correct answer is **D**.

D has been shaded on your answer sheet.

You have **20 minutes** for this section.

There are **25 questions** to answer.

Section 1: Multiple Choice

1. What is the value of 3 in 3,285,421?

- A 3,000,000
 - B 300
 - C 30,000
 - D 300,000
-

2. What is the highest common factor (HCF) of 30 and 40?

- A 20
 - B 10
 - C 30
 - D 40
-

3. Which shows $4\frac{2}{5}$ as a mixed number?

- A $8\frac{1}{5}$
 - B $8\frac{3}{5}$
 - C $7\frac{2}{5}$
 - D $8\frac{2}{5}$
-

4. Which of these fractions has the lowest value?

- A $\frac{1}{8}$
- B $\frac{7}{8}$
- C $\frac{3}{4}$
- D $\frac{1}{4}$

Section 1: Multiple Choice

5. 32 pints = ? gallons

- A 16 gallons
- B 2 gallons
- C 4 gallons
- D 8 gallons

6. Using the conversion table, convert the distance between the two houses from miles to km.



- A 64 km
- B 60 km
- C 40 km
- D 25 km

7. What is 1.3 l – 1 l?

- A 3l
- B 300l
- C 300ml
- D 30ml

Section 1: Multiple Choice

8.

Round this number to the nearest whole number.

2.812

A 2

B 3

C 4

D 5

9.

If a coin is thrown 56 times, how many times is it likely to land on heads?

A 28

B 56

C 30

D 14

10.

What is $\frac{45}{75}$ as a percentage?

A 60%

B 75%

C 45%

D 30%

11.

What is 28% as a fraction in its simplest form?

A $\frac{1}{4}$

B $\frac{7}{25}$

C $\frac{14}{100}$

D $\frac{2}{8}$

Section 1: Multiple Choice

12.

What is the missing prime factor of 40?

$$2 \times 2 \times 2 \times ?$$

A 3

B 5

C 6

D 4

13.

There are 400 books in the school library and 160 of them are non-fiction. What percentage are fiction?

A 60%

B 40%

C 30%

D 70%

14.

This tally chart shows the results of a poll in a magazine for dog lovers. It asked people to vote for their favourite breed.

What is the difference in the number of votes between Labrador and Alsatian?

Type of Dog	Number of people
Spaniel	
Poodle	
Labrador	
Alsatian	
Yorkshire Terrier	

A 24

B 37

C 9

D 52

Section 1: Multiple Choice

15.

Here are the number of shells Darcey collected from the beach over a week.
What is the median?

8, 9, 13, 8, 12, 13, 12

- A 11
 - B 9
 - C 12
 - D 8
-

16.

What is the lowest common multiple of 6 and 9?

- A 18
 - B 6
 - C 3
 - D 54
-

17.

Multiply 0.2 by 24.

- A 4.8
 - B 4.08
 - C 0.048
 - D 48
-

18.

At a GP clinic two doctors can see eight patients in an hour. How many patients can four doctors see in 30 minutes?

- A 8
 - B 10
 - C 12
 - D 16
-

Section 1: Multiple Choice

19. Paul bought a book from the book shop, which cost £6.23. How much change did Paul get back if he paid with a £20 note?

- A £13.07
 - B £12.77
 - C £6.17
 - D £13.77
-

20. A box contains 2 red pens, 3 blue pens and 4 black pens. A pen is picked at random. What is the probability of picking a black pen?

- A $\frac{2}{9}$
 - B 0
 - C $\frac{4}{9}$
 - D $\frac{7}{9}$
-

21. Ottoline threw a ball into the air three times. The first time she threw the ball 1.798 metres into the air. The second time she threw it 2.005 metres in the air and then the third time she threw it 1.998 metres into the air. What was the difference between her highest and lowest throw?

- A 0.207 metres
 - B 0.270 metres
 - C 0.203 metres
 - D 0.204 metres
-

22. Find 28% of 200.

- A 55
 - B 56
 - C 57
 - D 58
-

Section 1: Multiple Choice

23. What is the difference between the highest and lowest number of delays?

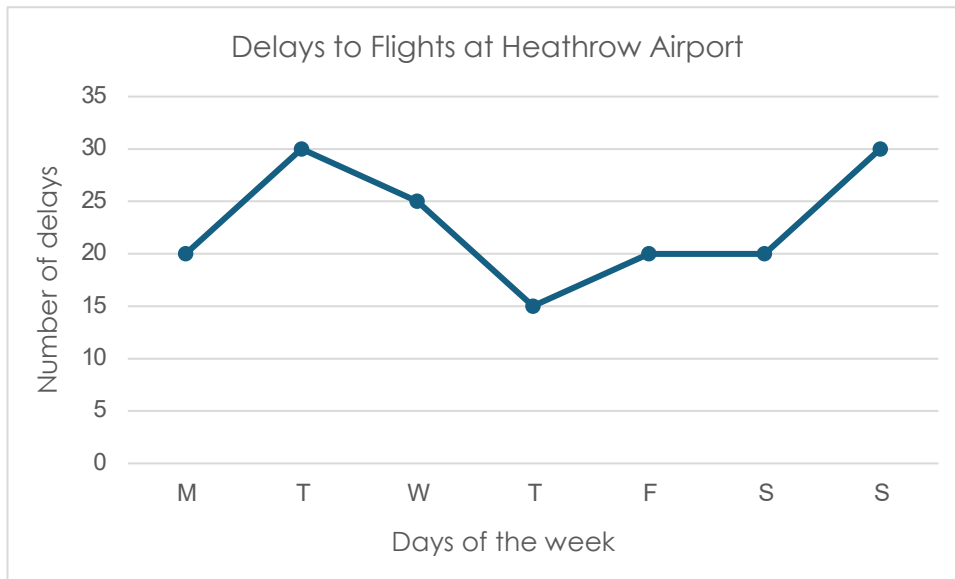

- A 20
B 15
C 30
D 25

Some adults were asked which countries they have visited.

24. Here is a Venn diagram showing the situation. How many adults visited France?

G = Germany and F = France

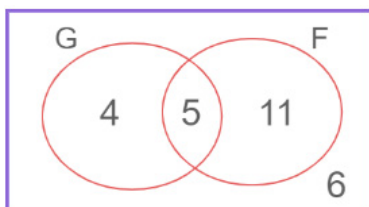

- A 11
B 4
C 16
D 7

Section 1: Multiple Choice

25. A class of thirty students take a test. If five sixths of the class pass, how many students need to retake the test?

A 30

B 10

C 15

D 5

Section 2: Free Response

Instructions

Read each question carefully.

You can use the space after each question for working out, but you will not get any marks for your working out.

Write your answers on your answer sheet by writing **one** number in each box.

Example

i

A rectangle has a length of 5cm and a width of 3cm. What is the perimeter?

The correct answer is **16cm**.

This has been marked on your answer sheet.

You have **20 minutes** for this section.

There are **20 questions** to answer.

Section 2: Free Response

1. If Fiona gets a full book of stickers for good behaviour from school, she will get a treat from her Mum. There are eight pages in a book and 20 stickers per page. If Fiona can earn a maximum of four stickers a day at school, what is the shortest amount of days at school before she can get her treat?

2. The ratio of blue and black pens in the pen box is 3:4. There are 60 blue pens. How many black pens are there?

3. Find the number that continues the sequence in the most sensible way.
222, ?, 112, 72, 42, 22

4. Suzie is 12 and Angela is 8. Their aunt gives them £60 to be shared in the ratio of their ages. How much will Angela get?

5. What is the numeral for five million, four hundred thousand and one?

6. If a rectangle was drawn on the graph below and three of its vertices were (3,4), (8,4) and (3,7). What are the coordinates of the missing vertex?

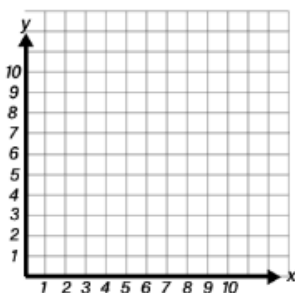

Section 2: Free Response

7. What are the coordinates of the HSS Minor?

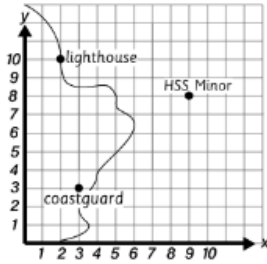

8. Find the number that continues the series in the most sensible way.
13, 15, 18, 22, 27, ?

9. $a = 4$, $b = 2$ and $c = 8$
 $3a + 5b - c = ?$

10. A plastic container holds 1.7 litres and a bottle holds 1150ml. What is the difference in the capacity of the plastic container and the bottle?

11. One small cube has a volume of 3cm^3 . If a larger cube is made up of 16 of the smaller cubes, what will the volume of the larger cube be?

12. Find the number that continues the sequence in the most sensible way.
2, 4, 12, 48, 240, ?

13. Round 18,621 to the nearest 100.

Section 2: Free Response

14. Round 18,621 to the nearest 10.

15. What is the square root of 144?

16. A toy store is having a sale. A toy car originally costs £30, but there is a 15% discount. What is the sale price of the toy car?

17. A rectangular swimming pool is being filled with water. If the pool is filled at a rate of 1.5 cubic metres per hour, how many hours will it take to fill the pool?

18. What is the mean of this set of numbers?

22, 43, 17, 10, 9, 35, 11

19. Let $A = 6$ and $C = 10$.

If $A^2 + B^2 = C^2$, what is the value of B ?

20. What number replaces the question mark to make the calculation correct?

$10^2 - (24 + ?) = (25 + 17) \div 3$

ANSWER SHEET – Mock B Paper 3

Maths – Multiple Choice

Questions

- | | A | B | C | D |
|-----|-----------------------|-----------------------|-----------------------|-----------------------|
| 1. | <input type="radio"/> | <input type="radio"/> | <input type="radio"/> | <input type="radio"/> |
| 2. | <input type="radio"/> | <input type="radio"/> | <input type="radio"/> | <input type="radio"/> |
| 3. | <input type="radio"/> | <input type="radio"/> | <input type="radio"/> | <input type="radio"/> |
| 4. | <input type="radio"/> | <input type="radio"/> | <input type="radio"/> | <input type="radio"/> |
| 5. | <input type="radio"/> | <input type="radio"/> | <input type="radio"/> | <input type="radio"/> |
| 6. | <input type="radio"/> | <input type="radio"/> | <input type="radio"/> | <input type="radio"/> |
| 7. | <input type="radio"/> | <input type="radio"/> | <input type="radio"/> | <input type="radio"/> |
| 8. | <input type="radio"/> | <input type="radio"/> | <input type="radio"/> | <input type="radio"/> |
| 9. | <input type="radio"/> | <input type="radio"/> | <input type="radio"/> | <input type="radio"/> |
| 10. | <input type="radio"/> | <input type="radio"/> | <input type="radio"/> | <input type="radio"/> |
| 11. | <input type="radio"/> | <input type="radio"/> | <input type="radio"/> | <input type="radio"/> |
| 12. | <input type="radio"/> | <input type="radio"/> | <input type="radio"/> | <input type="radio"/> |
| 13. | <input type="radio"/> | <input type="radio"/> | <input type="radio"/> | <input type="radio"/> |
| 14. | <input type="radio"/> | <input type="radio"/> | <input type="radio"/> | <input type="radio"/> |
| 15. | <input type="radio"/> | <input type="radio"/> | <input type="radio"/> | <input type="radio"/> |

Questions

- | | A | B | C | D |
|-----|-----------------------|-----------------------|-----------------------|-----------------------|
| 16. | <input type="radio"/> | <input type="radio"/> | <input type="radio"/> | <input type="radio"/> |
| 17. | <input type="radio"/> | <input type="radio"/> | <input type="radio"/> | <input type="radio"/> |
| 18. | <input type="radio"/> | <input type="radio"/> | <input type="radio"/> | <input type="radio"/> |
| 19. | <input type="radio"/> | <input type="radio"/> | <input type="radio"/> | <input type="radio"/> |
| 20. | <input type="radio"/> | <input type="radio"/> | <input type="radio"/> | <input type="radio"/> |
| 21. | <input type="radio"/> | <input type="radio"/> | <input type="radio"/> | <input type="radio"/> |
| 22. | <input type="radio"/> | <input type="radio"/> | <input type="radio"/> | <input type="radio"/> |
| 23. | <input type="radio"/> | <input type="radio"/> | <input type="radio"/> | <input type="radio"/> |
| 24. | <input type="radio"/> | <input type="radio"/> | <input type="radio"/> | <input type="radio"/> |
| 25. | <input type="radio"/> | <input type="radio"/> | <input type="radio"/> | <input type="radio"/> |

ANSWER SHEET – Mock B Paper 3

Maths – Free Response

1.

--	--

 days

2.

--	--

3.

--	--	--

4. £

--	--

5.

	,				,			
--	---	--	--	--	---	--	--	--

6. (

	,	
--	---	--

)

7. (

	,	
--	---	--

)

8.

--	--

9.

--	--

10.

--	--	--

 ml

ANSWER SHEET – Mock B Paper 3

11.

--	--

 cm³

12.

	,			
--	---	--	--	--

13.

		,			
--	--	---	--	--	--

14.

		,			
--	--	---	--	--	--

15.

--	--

16. £

		.		
--	--	---	--	--

17.

--	--

 hours

18.

--	--

19.

--

20.

--	--



SPELLING LOG

Record any new spellings that you wish to practise in the table below.

Word	Sentence (word in context)

Explore

LEARNING

