

# Standard Format Test Book

Levels 4–6



**Name:**



# Contents Page

Your child will complete interim tests throughout this course. Interim tests will be completed at home and will then be marked and reviewed with their tutor the following week.

**The interim tests are designed to:**

- Check for learning of concepts covered.
- Highlight areas of strength and areas for additional practice.
- Practise exam techniques learnt in lessons under exam conditions.

Test	Content Covered	Page no.
Interim Test 1 Maths	Place Value, Fractions, Decimals, Conversion & Measurement, Factors & Multiples, Function Machines	5–6
Interim Test 1 English	Comprehension, Spelling: Plurals, Nouns Verbs & Tenses, Commas, Hyphens, Parentheses & Dashes	7–11
Interim Test 1 VR	Move a Letter, Missing Word, Opposite Meaning, Word Connection, Number Series, Reading for Information	12–15
Interim Test 1 NVR	Series, Odd One Out, Similarities, Codes, Analogies, Matrices	16–23
Interim Test 2 Maths	Interpreting Data, Mean, Median, Mode & Range, Problem Solving, Perimeter & Area, Percentages, Number Squares	25–28
Interim Test 2 English	Comprehension, Tricky Spellings, Colons, Semicolons & Apostrophes, Homophones	29–32
Interim Test 2 VR	Letter Connections, Compound Words, Coded Maths, Insert a Letter, Closest Meaning, Rhyming Synonyms	33–36
Interim Test 2 NVR	Odd Shaped Matrices, Hidden Shapes, Merge Shapes, 2D Composite Shapes, 3D Plan Views, 3D Cube Nets	37–42
Interim Test 3 Maths	Volume & Capacity, Ratio, Probability, 2D Shapes, Symmetry, 3D Shapes, Transformations, Equations & Algebra, Sequences, Special Numbers	44–47
Interim Test 3 English	Comprehension, Silent Letters, Similes, Metaphors & Personification, Subject & Object, Sentences, Phrases & Clauses, Pronouns, Prepositions & Conjunctions	48–51
Interim Test 3 VR	Word Rules, Hidden Word, Make a Word, Complete the Sum, Number Logic, Same Meaning, Jumbled Sentences, Anagrams, Letter Series, Related Words, Word Letter Codes, Word Number Codes	52–54
Interim Test 3 NVR	Folded Paper, Identical Shapes, Corresponding Shapes, Triangle Series, Triangle Matrices	55–61
Maths Mock Paper A		63–72
English Mock Paper A		74–85
VR Mock Paper A		87–98
NVR Mock Paper A		100–123
Maths Mock Paper B		125–133
English Mock Paper B		134–146
VR Mock Paper B		147–158
NVR Mock Paper B		159–178

# Information for Interim Tests

Interim papers have been scheduled in to the year-long 11Plus / Entrance Exam course planner and should be completed only when they appear in the course planner.

Each interim test is broken down into maths, English, verbal reasoning and non-verbal reasoning papers. Each paper includes a sample of questions from the topics taught in previous weeks.

**ALL TESTS WILL BE COMPLETED AT HOME.** Please make sure you bring your book to your lesson the week after a test has been completed, for marking and review.

**Your tutor will inform you when a test should be completed.**

## Which tests should I complete?

Your tutor will direct you to **complete the relevant sections** depending on the course planner you are following and the exam you are preparing for.

Some children will complete all sections of each interim test if they cover maths, English, verbal-reasoning and non-verbal reasoning in their 'course planner sessions'. If one or more of these subjects has been omitted from your course planner, then you will not be required to complete the interim tests associated with these topics.

Just like in any exam, you may be faced with questions that you have not yet been taught. Have a good go at these questions and use the '**topic practice**' area of Compass for **further practice** if needed.

## Exam 'Top Tips'

- **Listen carefully** – to any explanations or instructions you are given.
- **Work accurately** – you may have optional answers, so choose the most reasonable answer if you don't know for sure.
- **Move on if stuck** – if you are stuck on a question, move on. Remember, you need to complete enough questions to score well.
- **Read questions carefully** – including instructions on how to answer questions.
- **Work speedily** – often the biggest challenge in the exam is completing enough questions to gain top marks.
- **Don't stop!** – Use all the time you are given. If you finish before the time is up, use this time to check your answers are accurate.

# Information for Interim Tests

Maths and English questions are a mix of free response and multiple-choice questions. In free response questions, you will be asked to write a number, word, sentence or short paragraph on the lines provided. For multiple-choice questions you'll be asked to circle the correct answer.

All verbal reasoning and non-verbal reasoning questions are multiple choice. Circle the correct answer from the options provided. An example is shown below, showing that 'C. u' is the chosen answer for this question.

1.   pound                      moth

A. p

B. o

C. u

D. n

E. d

## Marking and Feedback

Once you have completed an 'interim test' you will mark it alongside your tutor. Add your score next to each test on the score sheet on Page 4.

Reflecting helps you to develop your skills and review their effectiveness. To be self-aware is to be able to realistically assess your strengths, areas for development and set goals, while maintaining a positive mindset. You will get some time after each test for self-reflection and an opportunity to use Compass to work on any tricky topics from the test.

There is dedicated time within each course planner to mark and review each test. **If you would like access to the answers for each of the tests within this book, please scan the QR code below.**



# Results Page

After completing and marking each interim test or mock paper, record your score in the table below.

Test	Content Covered	Score
Interim Test 1 Maths	Place Value, Fractions, Decimals, Conversion & Measurement, Factors & Multiples, Function Machines	
Interim Test 1 English	Comprehension, Spelling: Plurals, Nouns Verbs & Tenses, Commas, Hyphens, Parentheses & Dashes	
Interim Test 1 VR	Move a Letter, Missing Word, Opposite Meaning, Word Connection, Number Series, Reading for Information	
Interim Test 1 NVR	Series, Odd One Out, Similarities, Codes, Analogies, Matrices	
Interim Test 2 Maths	Interpreting Data, Mean, Median, Mode & Range, Problem Solving, Perimeter & Area, Percentages, Number Squares	
Interim Test 2 English	Comprehension, Tricky Spellings, Colons, Semicolons & Apostrophes, Homophones	
Interim Test 2 VR	Letter Connections, Compound Words, Coded Maths, Insert a Letter, Closest Meaning, Rhyming Synonyms	
Interim Test 2 NVR	Odd Shaped Matrices, Hidden Shapes, Merge Shapes, 2D Composite Shapes, 3D Plan Views, 3D Cube Nets	
Interim Test 3 Maths	Volume & Capacity, Ratio, Probability, 2D Shapes, Symmetry, 3D Shapes, Transformations, Equations & Algebra, Sequences, Special Numbers	
Interim Test 3 English	Comprehension, Silent Letters, Similes, Metaphors & Personification, Subject & Object, Sentences, Phrases & Clauses, Pronouns, Prepositions & Conjunctions	
Interim Test 3 VR	Word Rules, Hidden Word, Make a Word, Complete the Sum, Number Logic, Same Meaning, Jumbled Sentences, Anagrams, Letter Series, Related Words, Word Letter Codes, Word Number Codes	
Interim Test 3 NVR	, Folded Paper, Identical Shapes, Corresponding Shapes, Triangle Series, Triangle Matrices	
Maths Mock Paper A		
English Mock Paper A		
VR Mock Paper A		
NVR Mock Paper A		
Maths Mock Paper B		
English Mock Paper B		
VR Mock Paper B		
NVR Mock Paper B		



## INTERIM TEST 1 – MATHS

- Interim Test 1 – Maths includes 15 questions.
- You have **15 minutes** to complete this test.
- Write your answers on the lines provided or circle the correct answer on your test paper.

1. Write the numeral for twenty-two thousand, six hundred and fifty-four?

**Answer:** \_\_\_\_\_

2. What is the value of 8 in 78,321?

**Answer:** \_\_\_\_\_

3. Show  $\frac{28}{84}$  in its simplest form?

**Answer:** \_\_\_\_\_

4. Write  $3\frac{1}{7}$  as a mixed number?

**Answer:** \_\_\_\_\_

5. A pair of trainers costs £56. A special offer means you can buy a second pair of trainers for  $\frac{3}{7}$  of the original cost. How much does the second pair of trainers cost?

**Answer:** \_\_\_\_\_

6. Which decimal has the lowest value?

A. 0.378

B. 3.078

C. 0.873

D. 0.078

E. 0.387

7.  $2.31 \times 7 =$

**Answer:** \_\_\_\_\_

8. I have two bags of sweets. One bag weighs 63.28g and the other bag weighs 52.65g. What is the difference in weight of the two bags of sweets?

**Answer:** \_\_\_\_\_g

9. Convert 2,549 grams into kilograms.

**Answer:** \_\_\_\_\_kg

10. Alex ran 890cm. How far did they run in metres?

**Answer:** \_\_\_\_\_m

11. Complete the function machine below.

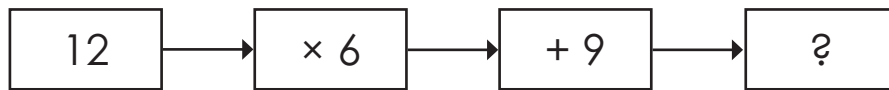

**Answer:** \_\_\_\_\_

12. Complete the function machine below.

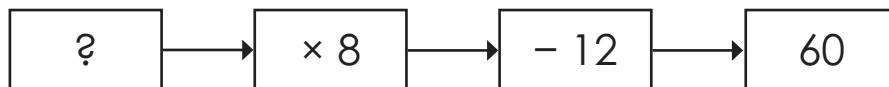

**Answer:** \_\_\_\_\_

13. Here is a list of factors of 24: 1, 2, 4, 6, 8, 12, 24.  
Which factor is missing?

**Answer:** \_\_\_\_\_

14. What is the lowest common multiple of 6 and 9?

**Answer:** \_\_\_\_\_

15. What is the highest common factor of 12 and 18?

**Answer:** \_\_\_\_\_

### END OF INTERIM PAPER 1 MATHS





## INTERIM TEST 1 – ENGLISH

- Interim Test 1 – English test includes 20 questions.
- You have **20 minutes** to complete this test.
- Write your answers on the lines provided or circle the correct answer on your test paper.

**Read the extract then answer the questions that follow.**

### The Old Gentleman

Here in the deep silence of the sleeping country the only things that went by were the trains. They seemed to be all that was left to link the children to the old life that had once been theirs.

Straight down the hill in front of Three Chimneys the daily passage of their six feet began to mark a path across the crisp, short turf. They began to know the hours when certain trains passed, and they gave names to them. The 9.15 up was called the Green Dragon. The 10.7 down was the Worm of Wantley. The midnight town express, whose shrieking rush they sometimes woke from their dreams to hear, was the Fearsome Fly-by-night. Peter got up once, in chill starshine, and, peeping at it through his curtains, named it on the spot.

It was by the Green Dragon that the old gentleman travelled. He was a very nice looking old gentleman, and he looked as if he were nice, too, which is not at all the same thing. He had a fresh-coloured, clean-shaven face and white hair, and he wore rather oddshaped collars and a top-hat that wasn't exactly the same kind as other people's. Of course the children didn't see all this at first. In fact the first thing they noticed about the old gentleman was his hand.

It was one morning as they sat on the fence waiting for the Green Dragon, which was three and a quarter minutes late by Peter's Waterbury watch that had been given him on his last birthday.

"The Green Dragon's going where Father is," said Phyllis; "if it were a really real dragon, we could stop it and ask it to take our love to Father."

"Dragons don't carry people's love," said Peter; "they'd be above it."

"Yes, they do, if you tame them thoroughly first. They fetch and carry like pet spaniels," said Phyllis, "and feed out of your hand. I wonder why Father never writes to us."

"Mother says he's been too busy," said Bobbie; "but he'll write soon, she says." "I say," Phyllis suggested, "let's all wave to the Green Dragon as it goes by. If it's a magic dragon, it'll understand and take our love to Father. And if it isn't, three waves aren't much. We shall never miss them."

So when the Green Dragon tore shrieking out of the mouth of its dark lair, which was the tunnel, all three children stood on the railing and waved their pocket-handkerchiefs without stopping to think whether they were clean handkerchiefs or the reverse. They were, as a matter of fact, very much the reverse.

And out of a first-class carriage a hand waved back. A quite clean hand. It held a newspaper. It was the old gentleman's hand.

*The Railway Children* by Edith Nesbit



1. What does the author suggest is the only link left to the children's old life?
  - A countryside
  - B trains
  - C the old gentleman
  - D Three Chimneys
  - E Green Dragon

2. What is the main subject of the second paragraph?
  - A It is about the arrival and departure times of the trains.
  - B It is about the noise of the trains passing.
  - C It is about the names the children gave the trains.
  - D It is about the number of trains that visit the station.
  - E It is about trains they had travelled on.

3. Where did the children stand to watch the trains arrive and leave the station?

---

---

---

4. What was the first thing the children noticed about the old gentleman in the third paragraph? (Line 13)

---

5. 'It was one morning as they sat on the fence' (Line 14).

In the sentence above, which word is the verb?

---





6. Why do you think the old gentleman is of interest to the children?  
**Write your answer in a full sentence.**

---

---

---

7. How many minutes late is the Green Dragon, according to Peter's Waterbury watch? (Lines 14–15)

---

8. Which word is closest in meaning to 'reverse' in line 27?

- A Go backward
- B Opposite
- C Upturn
- D Change
- E Alter

### Grammar: Nouns, Verbs, Tenses

In the questions below, choose the most appropriate word to complete the passage.  
Circle your answer.

9. The Sydney Opera House is a world-renowned building found in Sydney, Australia. It is a place where famous shows and concerts take place. It is \_\_\_\_\_ on Bennelong Point directly next to the harbour, so it boasts fantastic views.

A. location      B. locater      C. locate      D. located      E. locates

10. Maggie Aderin-Pocock is a British space scientist and science \_\_\_\_\_. Her acclaimed work has ranged from making novel, bespoke, scientific instruments including hand-held land mine detectors and optical sub-systems for spacecraft, to co-hosting the BBC mainstay astronomy programme, The Sky at Night.

A. educator      B. teaches      C. education      D. teach      E. educations





11. Hideyo Noguchi was born in Fukushima, Japan in 1876. He was a doctor at the Institute of Infectious Diseases. In 1900, he \_\_\_\_\_ to the United States of America to work as a research assistant looking into poisonous snakes.
- A. moves      B. moving      C. moved      D. move      E. mover
12. Florence Nightingale was born in 1820 to an affluent \_\_\_\_\_ family. From a young age, she would go to the village neighbouring her family's estate to help the poor and ill.
- A. Britannia      B. British      C. Albion      D. Britain      E. Brit
13. Lewis Latimer was born in Massachusetts, United States of America in 1848. His parents had been enslaved and \_\_\_\_\_ to escape to freedom. He served in the navy during the American Civil War and after this, worked in a law firm.
- A. managed      B. manages      C. managing      D. manage      E. manager
14. Mary Somerville was born in Scotland in 1780. As a child, she was taught to read the Bible but her education was minimal, mainly focusing on skills that were deemed appropriate for a girl at the time, such as needlework and playing the piano. Despite this, Mary became \_\_\_\_\_ in reading and took it upon herself to learn Latin.
- A. interested      B. inter      C. interests      D. interest      E. interesting
15. Penguins are a species of \_\_\_\_\_ that live in the Southern Hemisphere. One of the things that makes them unique is their incredible swimming ability.
- A. fish      B. rodent      C. bird      D. reptile      E. mammal

**Punctuation: Commas, Hyphens, Parentheses & Dashes**

In the questions below, look for a punctuation mistake in the sentence. Select the group of words with the mistake. If there is no mistake, circle N.

- 16 Thomas (the man who worked at the station hadn't seen the missing ticket.

<b>A</b>	<b>B</b>	<b>C</b>	<b>D</b>	<b>N</b>
----------	----------	----------	----------	----------

- 17 Quick – we must set off for the airport immediately.

<b>A</b>	<b>B</b>	<b>C</b>	<b>D</b>	<b>N</b>
----------	----------	----------	----------	----------

- 18 Mum asked us to buy eggs, milk, bread tomatoes and chicken.

<b>A</b>	<b>B</b>	<b>C</b>	<b>D</b>	<b>N</b>
----------	----------	----------	----------	----------





## Plurals

In the questions below, write the correct plural for the word in brackets.

19 The friends visited six \_\_\_\_\_ (**country**) as they travelled through Europe.

**Answer:** .....

20 The \_\_\_\_\_ (**child**) explored the museum on their school trip.

**Answer:** .....

**END OF INTERIM PAPER 1 ENGLISH**

© Explore Learning Standard Format Levels 4-6 Test Book **Page 11**





## INTERIM TEST 1 – VR

- Interim Test 1 – VR test includes 20 questions.
- You have **10 minutes** to complete this test.
- Circle the correct answer on your test paper.

In the questions below, move **one** letter from the word on the left to the word on the right, to create **two** new words. The letters **must not** be rearranged. Both new words must make sense. Choose the letter that moves.

- pound                      moth

A. p                      B. o                      C. u                      D. n                      E. d
- thrust                      sift

A. t                      B. r                      C. s                      D. h                      E. u
- beaker                      state

A. b                      B. e                      C. a                      D. k                      E. e
- shimmer                      tanks

A. s                      B. m                      C. i                      D. e                      E. h

In the sentence below, one word in capitals has had **three consecutive letters taken out**. These three letters on their own make **one correctly spelt word**, without changing the order. Choose the three-letter word from the options below.

- Chicken, milk and cheese are all foods that are high in **PEIN**.

A. rat                      B. pat                      C. rot                      D. lap                      E. rip
- The shop gives discount if you buy **MULLE** copies.

A. tip                      B. eat                      C. tap                      D. cap                      E. map



7. We were **SKING** to the teacher about upcoming exams.

- A. oat                      B. eat                      C. pat                      D. pea                      E. tat

Find the **two** words, one from each group, that are most opposite in meaning. Select the **two** words from the options below.

8. (limited, sequence, sturdy)                      (indifferent, boundless, prepare)

- A. limited                      X. indifferent  
B. sequence                      Y. boundless  
C. sturdy                      Z. prepare

9. (enthusiastic, advance, eager)                      (retreat, earnestly, lead)

- A. enthusiastic                      X. retreat  
B. advance                      Y. earnestly  
C. eager                      Z. lead

10. (demonstrate, duty, integrated)                      (secluded, exhibit, manifest)

- A. demonstrate                      X. secluded  
B. duty                      Y. exhibit  
C. integrated                      Z. manifest

Find the **two** words, one from each group, that will complete the sentence in the best way. Select the **two** words from the options below.

11. Scales is to (height, weight, length) as thermometer is to (width, depth, temperature)

- A. height                      X. width  
B. weight                      Y. depth  
C. length                      Z. temperature





12. cat is to (cub, milk, kitten) as deer is to (Christmas, fawn, field)

- |           |              |
|-----------|--------------|
| A. cub    | X. Christmas |
| B. milk   | Y. fawn      |
| C. kitten | Z. field     |

13. knits is to (stink, scarf, socks) as live is to (evil, bad, gloves)

- |          |           |
|----------|-----------|
| A. stink | X. evil   |
| B. scarf | Y. bad    |
| C. socks | Z. gloves |

In the questions below, find the number that continues the series in the most sensible way.

14. 1045, 820, 595, 370, 145, ?

- |        |        |        |       |       |
|--------|--------|--------|-------|-------|
| A. -80 | B. 120 | C. -76 | D. 80 | E. 98 |
|--------|--------|--------|-------|-------|

15. 1, 3, 7, 15, 31, ?

- |       |       |       |       |       |
|-------|-------|-------|-------|-------|
| A. 93 | B. 12 | C. 45 | D. 75 | E. 63 |
|-------|-------|-------|-------|-------|

16. -62, -36, -10, 16, 42, ?

- |       |       |       |       |       |
|-------|-------|-------|-------|-------|
| A. 66 | B. 48 | C. 57 | D. 62 | E. 68 |
|-------|-------|-------|-------|-------|

17. 6, 14, 30, 62, 126, ?

- |        |        |        |        |        |
|--------|--------|--------|--------|--------|
| A. 260 | B. 254 | C. 258 | D. 252 | E. 261 |
|--------|--------|--------|--------|--------|

18. Cara is triple the age that Hamza was last year. Denzel is four years older than Hamza was three years ago. Logan is double the age of Denzel. Hamza is 19 next year.

**Who is the second oldest?**

- |         |          |           |          |
|---------|----------|-----------|----------|
| A. Cara | B. Hamza | C. Denzel | D. Logan |
|---------|----------|-----------|----------|







19. Hassan, Poppy, Callie and Dillon all fancied a takeaway for dinner so they went to the drive-through. Hassan, Dillon and Callie all got fries. Poppy got mozzarella dippers. Poppy and Callie got a beef burger. Dillon got chicken nuggets as he doesn't like beef. Hassan got a fish burger. Everyone who got fries also got a fizzy drink.

**Who got fries, a beef burger and a fizzy drink?**

- A. Hassan      B. Poppy      C. Callie      D. Dillon      E. Nobody

20. Matilda and Ruben together have 30 vinyl records. Matilda and Lucy have 24 vinyl records. Altogether the children have 42 vinyl records.

**How many vinyl records does Matilda have?**

- A. 8      B. 11      C. 16      D. 12      E. 14

**END OF INTERIM PAPER 1 VR**

© Explore Learning Standard Format Levels 4-6 Test Book Page 15





# INTERIM TEST 1 – NVR

- Interim Test 1 – NVR test includes 24 questions.
- You have **15 minutes** to complete this test.
- Circle the correct answer on your test paper.

In the questions below, choose the figure that completes the series.

1.

---

A.

B.

C.

D.

E.

2.

---

A.

B.

C.

D.

E.





3.

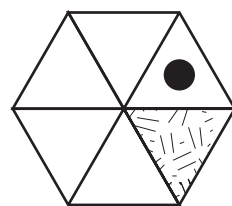
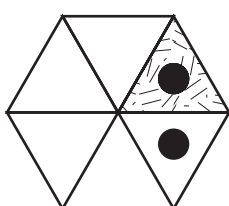
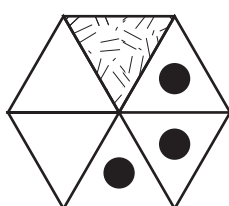
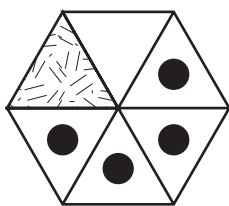

\_\_\_\_\_

A.

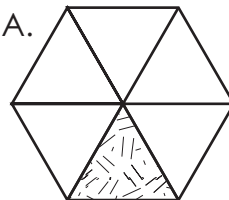

B.

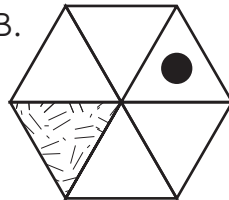

C.

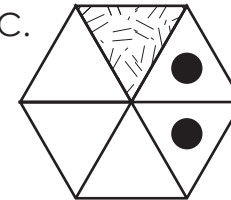

D.

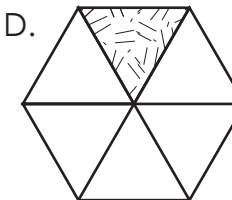

E.

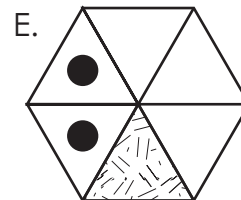

4.

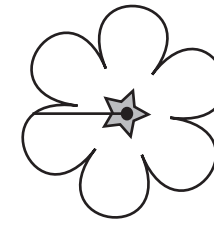
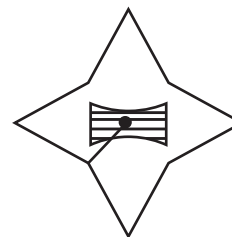
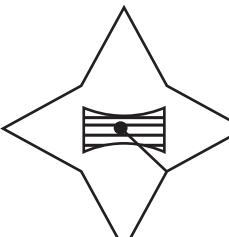
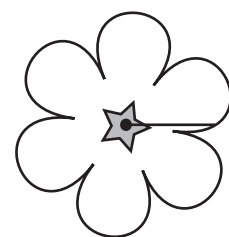

\_\_\_\_\_

A.

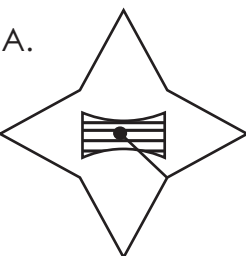

B.

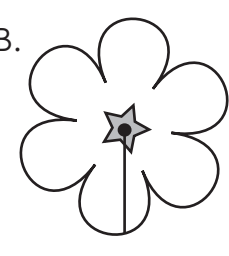

C.

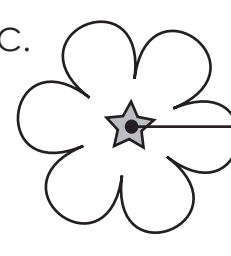

D.

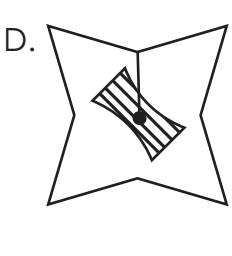

E.

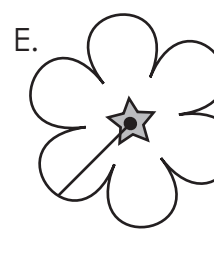

In the questions below, choose the figure that is the odd one out.

5.

A.

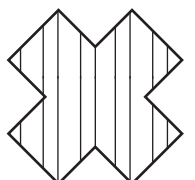

B.

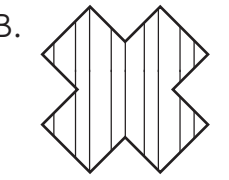

C.

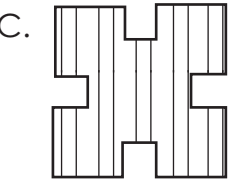

D.

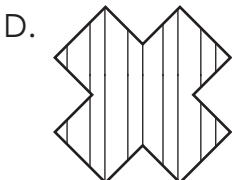

E.

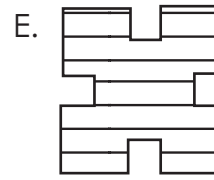

6.

A.

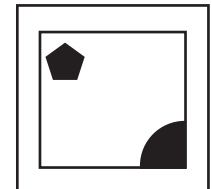

B.

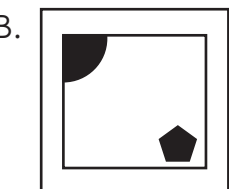

C.

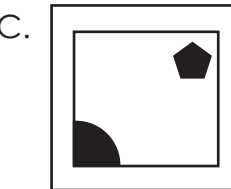

D.

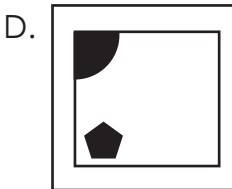

E.

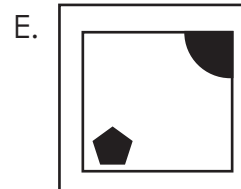

7.

A.

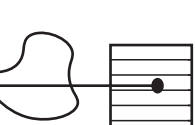

B.

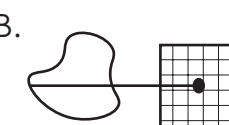

C.

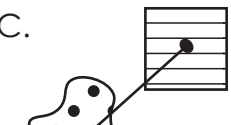















D.







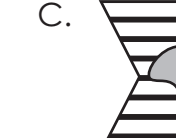



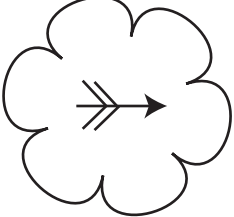
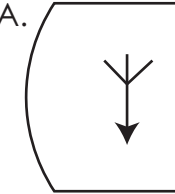

E.

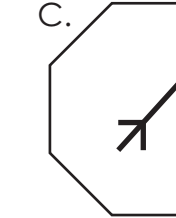
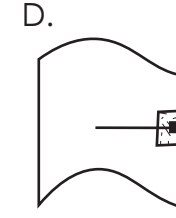
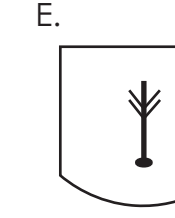

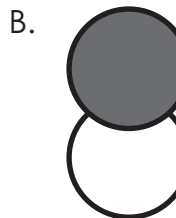

8. A.  B.  C.  D.  E. 
9. A.  B.  C.  D.  E. 
10. A.  B.  C.  D.  E. 

In the questions below, choose the answer option that is most similar to the figures in the question.

11.  
- A.  B.  C.  D.  E. 
12.  
- A.  B.  C.  D.  E. 





13.

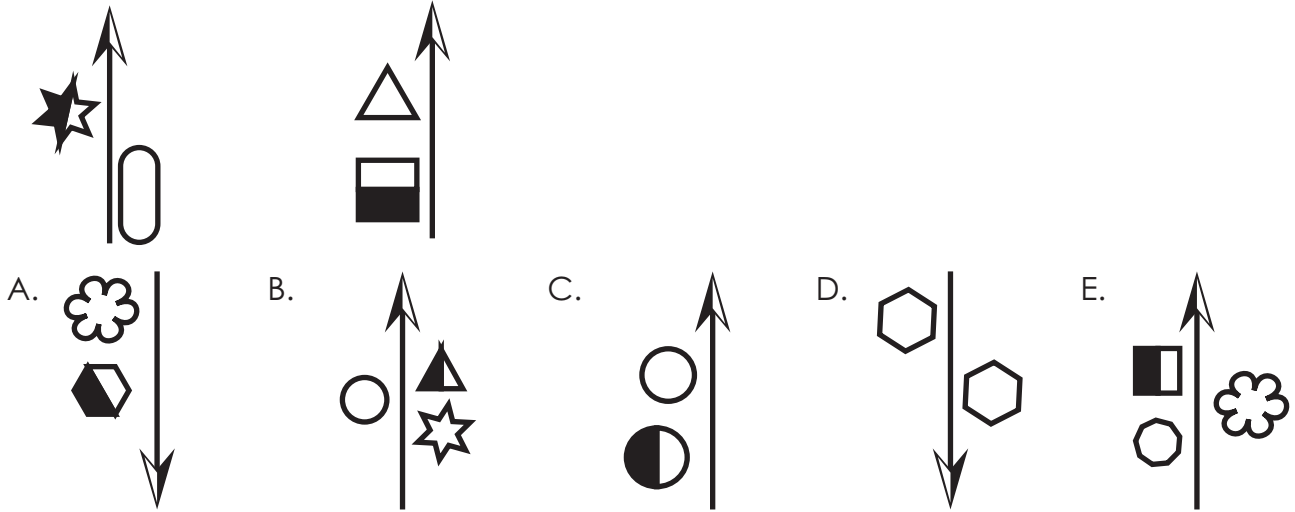

In the questions below, choose the missing code.

14.

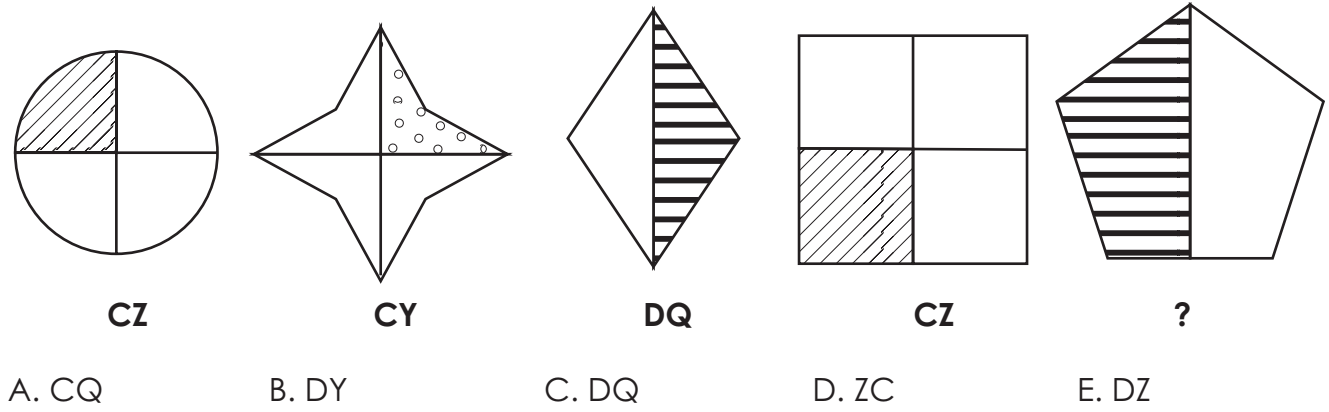

15.

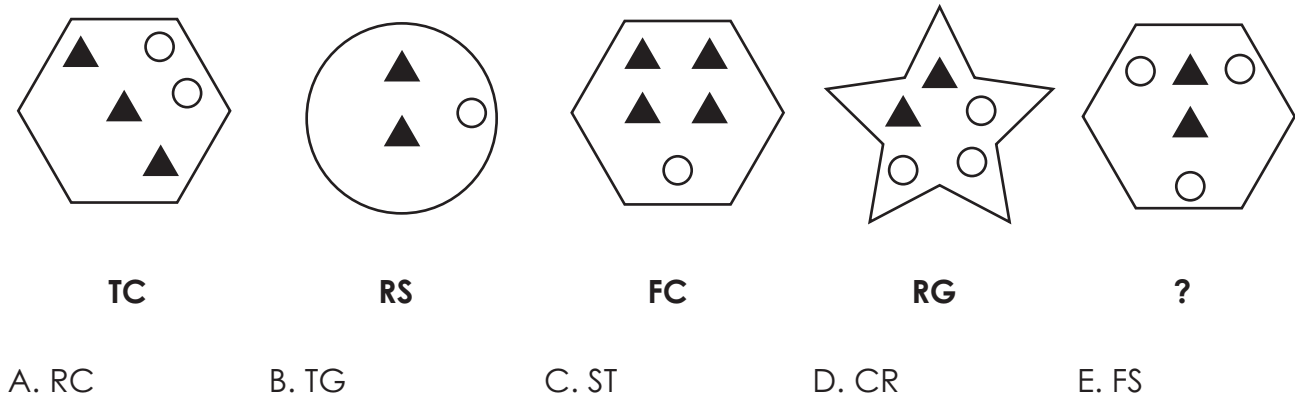



16.



FAH



XDH

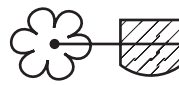

XAL

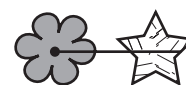

FVH

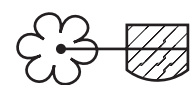

?

A. FAH

B. XAH

C. FAL

D. XDL

E. XAL

17.

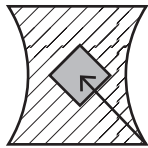

GHB

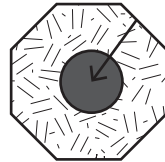

KJP



CHB



GJW

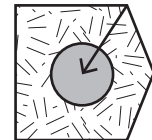

?

A. CHP

B. KJB

C. CJW

D. GJB

E. CJP

18.

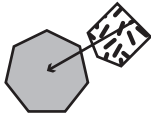

THV



SOV



THZ



SLZ



?

A. THV

B. TOZ

C. SOZ

D. THZ

E. SLV





In the questions below, choose the figure that completes the second pair in the same way as the first pair.

19.

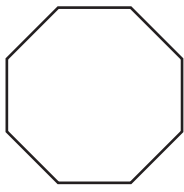

is to



as

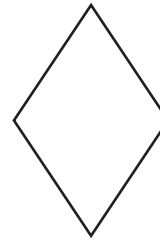

is to...

A.

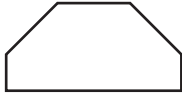

B.

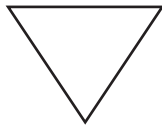

C.



D.

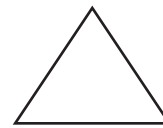

E.

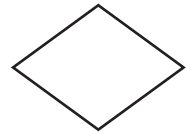

20.



is to

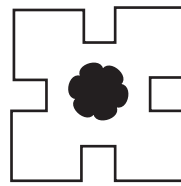

as



is to...

A.

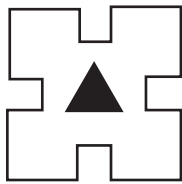

B.

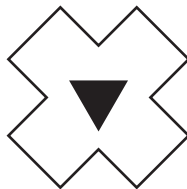

C.



D.



E.

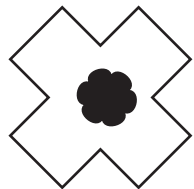

21.

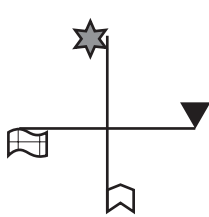

is to

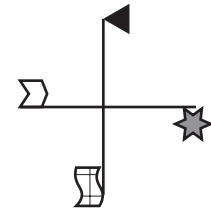

as

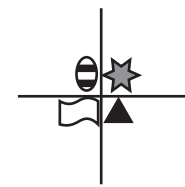

is to...

A.



B.

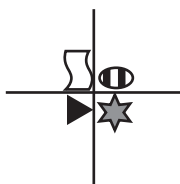

C.



D.



E.

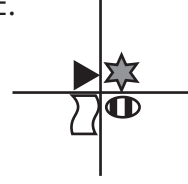



In the questions below, choose the figure that should fill the empty square.

22.

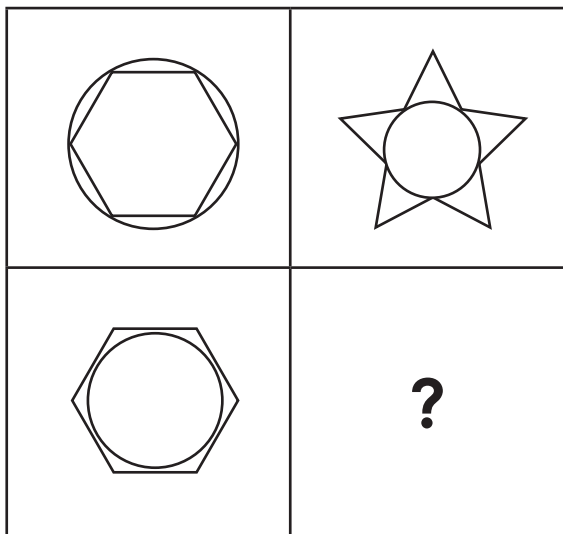

- A.
- B.
- C.
- D.
- E.

23.

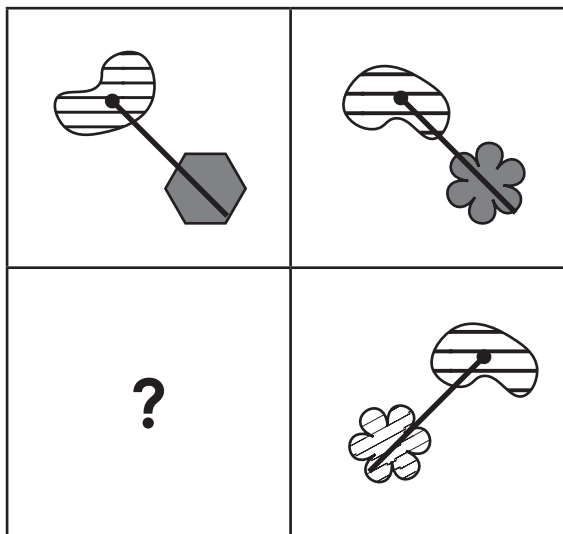

- A.
- B.
- C.
- D.
- E.







24.

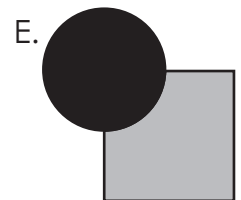
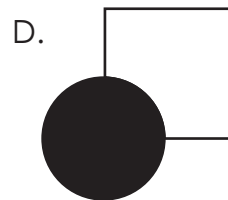
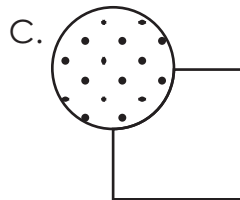
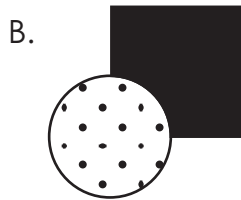
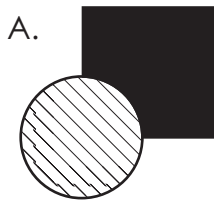
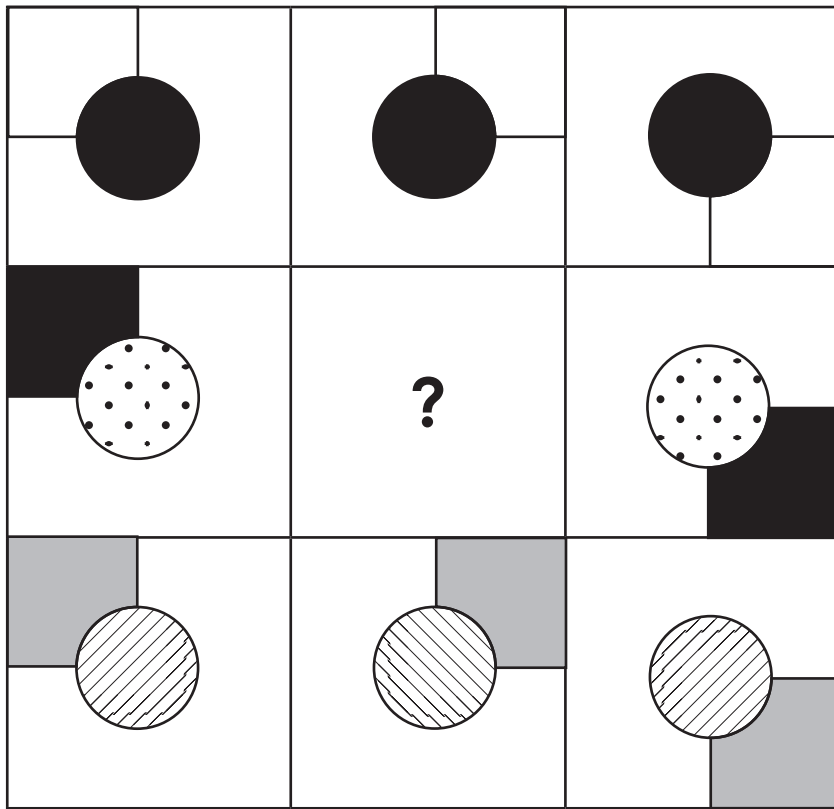

END OF INTERIM PAPER 1 NVR





# SELF REFLECTION

Take some time to reflect on your review test experience. Although they may sometimes feel stressful, exams can also be valuable learning opportunities.

## Your preparation

How confident did you feel going into the exam?



Did you prepare / revise for the test in any way?

---

---

## Your performance

Did you understand and follow the instructions given for the exam?

<input type="checkbox"/>	<input type="checkbox"/>
yes	no

Did you have enough time to answer all the questions in the exam?

<input type="checkbox"/>	<input type="checkbox"/>
yes	no

Which topics were you most confident answering?

---

---

Which topics were you least confident answering?

---

---

What emotions did you feel during the exam?

---

---

## What might you do differently next time?

In preparation for your next exam, write down one thing you will keep doing and one thing you will change for next time.

Keep	Change



## INTERIM TEST 2 – MATHS

- Interim Test 2 – Maths includes 17 questions.
- You have **15 minutes** to complete this test.
- Write your answers on the lines provided or circle the correct answer on your test paper.

1. What is 0.47 as a percentage?

**Answer:** \_\_\_\_\_

2. Find 30% of 340.

**Answer:** \_\_\_\_\_

3. A clothes shop has a mid-season sale. A coat costing £45 has a 20% discount. What is the discounted price of the coat in £?

**Answer:** \_\_\_\_\_

4. In a number square, each row, column and diagonal must add up to the same total. In the questions below, write the number that should be in place of the question mark.

?		7
13	9	5
	1	

**Answer:** \_\_\_\_\_

5.

26	5	
	17	23
?		8

**Answer:** \_\_\_\_\_

6.

6	27	
21	?	
18		

**Answer:** \_\_\_\_\_

Use the graph below to answer questions 7–9.

A school asked all their students to vote for their favourite sport. The bar chart below shows the results.

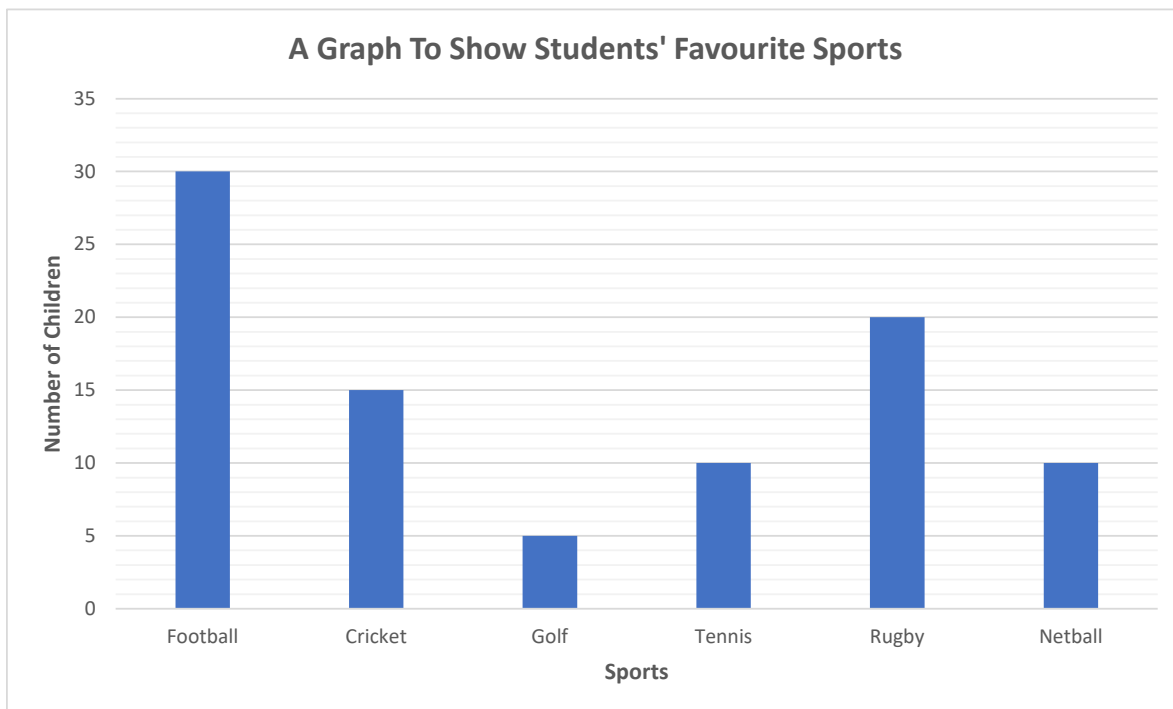

7. How many students are in the school?

**Answer:** \_\_\_\_\_

8. How many more children voted for rugby than tennis?

**Answer:** \_\_\_\_\_

9. Which two sports received the same number of votes?

**Answer:** \_\_\_\_\_

10. What is the mean of the data below?

**14, 8, 7, 18, 23**

**Answer:** \_\_\_\_\_

11. What is the range of the data below?

**50, 45, 39, 52, 65, 48, 33, 58, 52**

**Answer:** \_\_\_\_\_

12. Anisa has recorded how long she spent revising for her exams each day after school. Here is a record of time spent revising:

Monday	Tuesday	Wednesday	Thursday	Friday
80 minutes	120 minutes	45 minutes	100 minutes	95 minutes

What is the median amount of time she spent revising in minutes?

**Answer:** \_\_\_\_\_

13. Fence panels are 1.5 metres wide. The perimeter of the garden is 45 metres. How many panels are needed to put a fence around the garden?

**Answer:** \_\_\_\_\_

14. Jessica needs to send 15 letters. A stamp costs £0.75. She only has £6. How many letters is she unable to send?

**Answer:** \_\_\_\_\_

15. Each luggage compartment on the train takes 12 suitcases. Today there are 80 suitcases on the train. How many compartments will be full?

**Answer:** \_\_\_\_\_

16. What is the area of this shape?

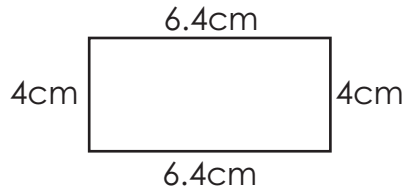

**Answer:** \_\_\_\_\_cm<sup>2</sup>

17. A rectangle has a length of 16cm and a breadth of 8cm. What is its perimeter?

**Answer:** \_\_\_\_\_cm

**END OF INTERIM PAPER 2 MATHS**



## INTERIM TEST 2 – ENGLISH

- Interim Test 2 – English test includes 15 questions.
- You have **15 minutes** to complete this test.
- Write your answers on the lines provided or circle the correct answer on your test paper.

**Read the poem then answer the questions that follow.**

### *I Wandered Lonely as a Cloud* by William Wordsworth

I wandered lonely as a cloud  
That floats on high o'er vales and hills,  
When all at once I saw a crowd,  
A host, of golden daffodils;

- 5 Beside the lake, beneath the trees,  
Fluttering and dancing in the breeze.

Continuous as the stars that shine  
And twinkle on the milky way,  
They stretched in never-ending line

- 10 Along the margin of a bay:  
Ten thousand saw I at a glance,  
Tossing their heads in sprightly dance.

The waves beside them danced; but they  
Out-did the sparkling waves in glee:

- 15 A poet could not but be gay,  
In such a jocund company:  
I gazed – and gazed – but little thought  
What wealth the show to me had brought:

For oft, when on my couch I lie

- 20 In vacant or in pensive mood,  
They flash upon that inward eye  
Which is the bliss of solitude;  
And then my heart with pleasure fills,  
And dances with the daffodils.

1. What word in the first stanza tells you there are a lot of daffodils?

---



2. Why does the speaker compare himself to a cloud in the first line?

---

---

---

3. Choose the word that is a synonym of 'wandered'.

- A thought
- B strolled
- C remain
- D settle
- E float

4. What is being compared to the stars in the sky in stanza 2?

---

5. **'Tossing their heads in sprightly dance' (line 12)**

What literary device is this an example of?

---

6. Using the context of the poem, choose the word that best defines the word 'jocund'. (Line 16)

- A cheerful
- B pensive
- C curious
- D admiration
- E sullen





7. What is the significance of the phrase 'inward eye' in the fourth stanza?

---

---

---

**Spelling: Tricky Words**

In these sentences there are some spelling mistakes. In each question, there is either one mistake or no mistake. Find the group of words with the mistake in it. If there is no mistake, circle N.

8. I guarante that you'll love this product or you'll get your money back!

<b>A</b>	<b>B</b>	<b>C</b>	<b>D</b>	<b>N</b>
----------	----------	----------	----------	----------

9. We tried to get tickets, but unfortunatley they were already sold out.

<b>A</b>	<b>B</b>	<b>C</b>	<b>D</b>	<b>N</b>
----------	----------	----------	----------	----------

10. You will receive a discount if you spend over £50.

<b>A</b>	<b>B</b>	<b>C</b>	<b>D</b>	<b>N</b>
----------	----------	----------	----------	----------

**Punctuation: Colons, Semicolons & Apostrophes**

In these sentences there are some punctuation mistakes. In each question, there is either one mistake or no mistake. Find the group of words with the mistake in it. If there is no mistake, circle N.

11. The two brothers' toy cars were lost in the garden.

<b>A</b>	<b>B</b>	<b>C</b>	<b>D</b>	<b>N</b>
----------	----------	----------	----------	----------

12. I have lived in a range of places: Madrid, Rome and Manchester.

<b>A</b>	<b>B</b>	<b>C</b>	<b>D</b>	<b>N</b>
----------	----------	----------	----------	----------



## Homophones

In the questions below, choose the correct homophone to complete the sentence. Mark the letter on your answer sheet.

13. I stood in \_\_\_\_\_ of their courage and determination.

- A. or                      B. awe                      C. oar

14. The \_\_\_\_\_ of the flowers was very strong and made me sneeze.

- A. scent                      B. sent                      C. cent

15. The doctor advised rest to give the injury time to \_\_\_\_\_.

- A. he'll                      B. heel                      C. heal

END OF INTERIM PAPER 2 ENGLISH





## INTERIM TEST 2 – VR

- Interim Test 2 – VR test includes 20 questions.
- You have **10 minutes** to complete this test.
- Circle the correct answer on your test paper.

In the questions below, find the letters that will complete the sentence in the best way. There is an alphabet line below to help you.

**A B C D E F G H I J K L M N O P Q R S T U V W X Y Z**

1. QR is to AH as AZ is to \_\_\_

- A. LP                      B. KP                      C. JQ                      D. JO                      E. JP

2. KJ is to VI as AB is to \_\_\_

- A. LA                      B. KA                      C. MB                      D. MZ                      E. KZ

3. SS is to UA as FF is to \_\_\_

- A. GO                      B. IN                      C. HO                      D. GN                      E. HN

In the questions below, find **two** words, **one** from each group, that together make **one** correctly spelt word, without changing the order of the letters. The word from the first group always comes first. Choose **both** words from the options below.

4. (sent straw book)

(berry house word)

- A. sent                      X. berry  
B. straw                      Y. house  
C. book                      Z. word



5. (over bottom sure) (word some coat)
- A. over X. word
- B. bottom Y. some
- C. sure Z. coat
6. (new crest proud) (found front foul)
- A. new X. found
- B. crest Y. front
- C. proud Z. foul
7. (scar weak ten) (flow fold frown)
- A. scar X. flow
- B. weak Y. fold
- C. ten Z. frown

In these question, letters stand for numbers. Use the code to work out the answer to the calculation. Choose the correct letter as your answer.

8. A = 5 B = 1 C = 8 D = 3 E = 6

$$(E \times C) + (2 \times B) \div 10 =$$

9. A = 18 B = 12 C = 19 D = 11 E = 14

$$B + D + E - C =$$

10. A = 38 B = 7 C = 3 D = 6 E = 8

**Subtract the sum of B and C from the product of D and E.**

11. A = 4 B = 3 C = 105 D = 9 E = 108

**Find the product of ADB and subtract B.**





In the questions below, find **one** letter that will complete the word in front of the brackets and begin the word after the brackets. The **same letter** must fit into both sets of brackets.

12. CLAS (\_\_\_\_) EAT      FIS (\_\_\_\_) OPE

A. P                      B. T                      C. H                      D. M                      E. S

13. MEA (\_\_\_\_) APE      CAR (\_\_\_\_) UNE

A. T                      B. K                      C. P                      D. S                      E. L

14. KINDRE (\_\_\_\_) ROVE      KIN (\_\_\_\_) EVISE

A. E                      B. T                      C. S                      D. A                      E. D

Find the **two** words, one from each group, that are most similar in meaning. Select the **two** words from the options below.

15. (incessant durable sturdy)                      (continual season alternative)

A. incessant    X. continual

B. durable    Y. season

C. sturdy     Z. alternative

16. (ebullient athletic sluggish)                      (lazy competitive exuberant)

A. ebullient    X. lazy

B. athletic    Y. competitive

C. sluggish     Z. exuberant

17. (sociable amiable withdrawn)                      (unfriendly introverted silent)

A. sociable     X. unfriendly

B. amiable    Y. introverted

C. withdrawn    Z. silent



Work out the correct word to complete the sentence. The word on the left in bold is a clue. It rhymes with a synonym of the missing word, but not the word itself.

18. **empower** It rained last night but it was just a \_\_\_\_\_.
- A. season      B. shower      C. flower      D. sprinkle      E. flood
19. **thrive** He was not sure if the fire was still \_\_\_\_\_ after dousing the flames.
- A. alive      B. flourishing      C. extinct      D. president      E. drive
20. **squeal** They're convinced that the painting is \_\_\_\_\_.
- A. real      B. counterfeit      C. genuine      D. surreal      E. bogus

END OF INTERIM PAPER 2 VR



# INTERIM TEST 2 – NVR

- Interim Test 2 – NVR test includes 20 questions.
- You have **15 minutes** to complete this test.
- Circle the correct answer on your test paper.

In the questions below, choose the figure that should fill the empty space.

1.

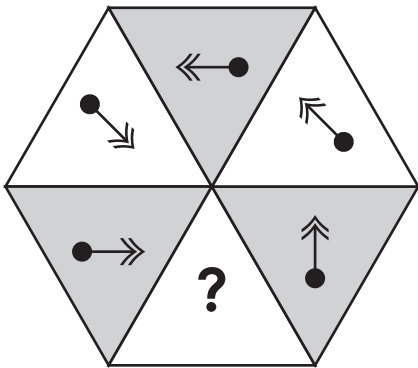

A.

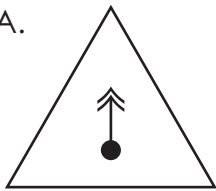

B.

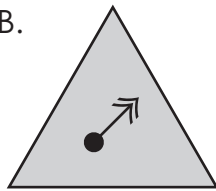

C.

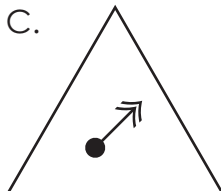

D.

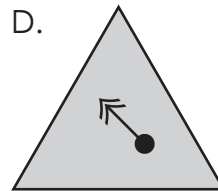

E.

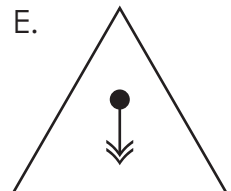

2.

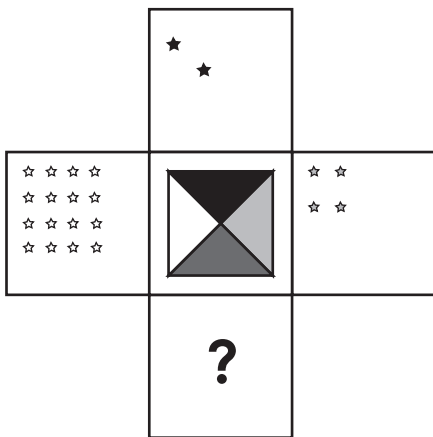

A.



B.



C.



D.



E.





In the questions below, look at the shape on the left. In which drawing on the right is it hidden? (Note: it is the same size and is facing the same direction.)

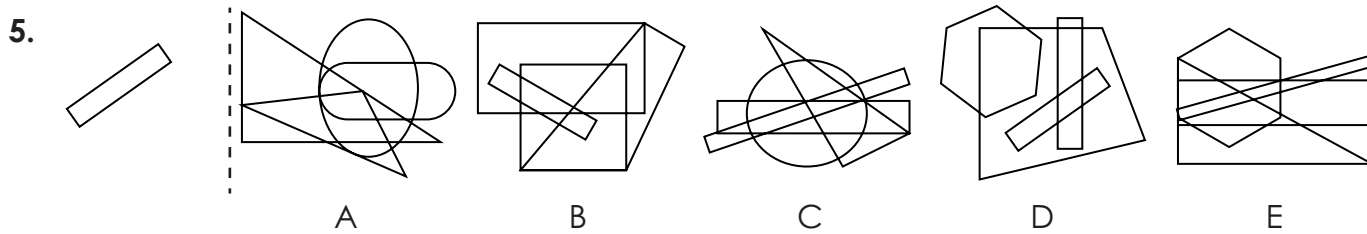
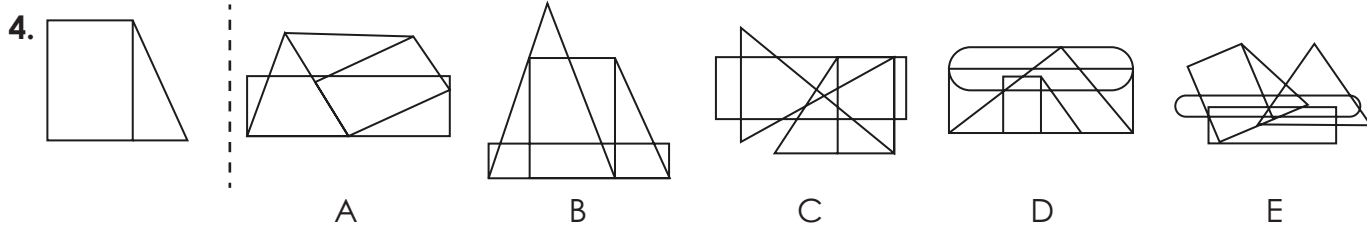
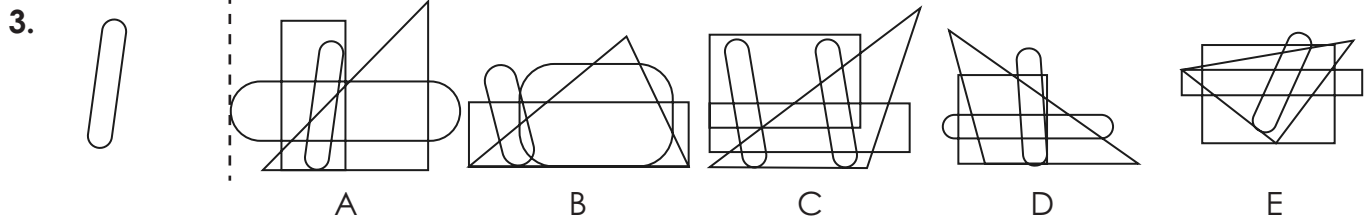

In the questions below, choose the answer option that combines the two figures. The figures may change position, but will not rotate.

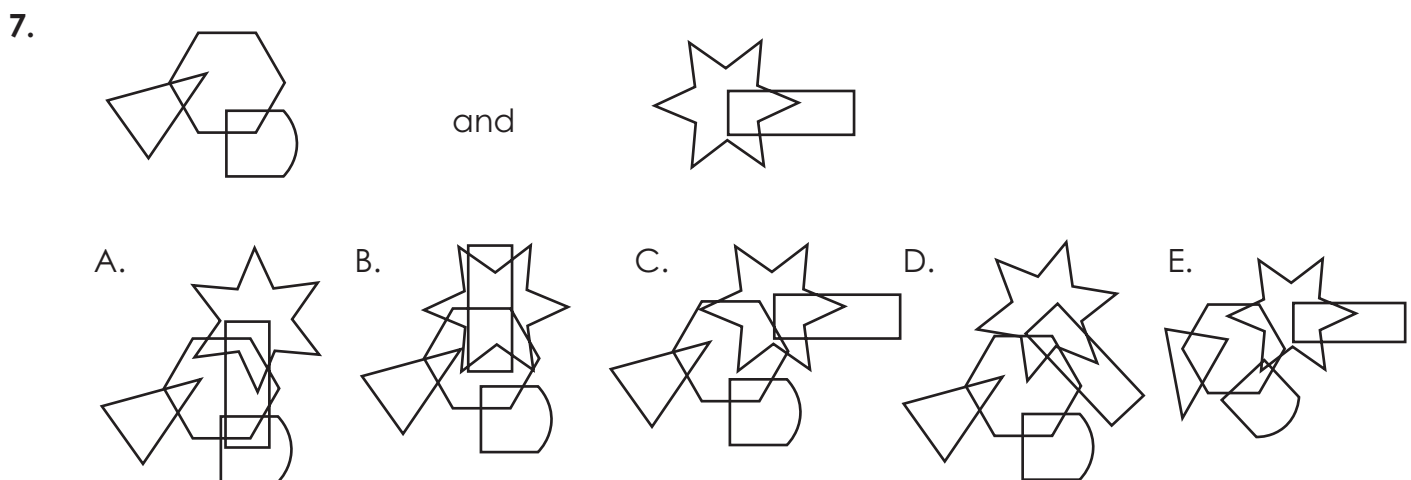
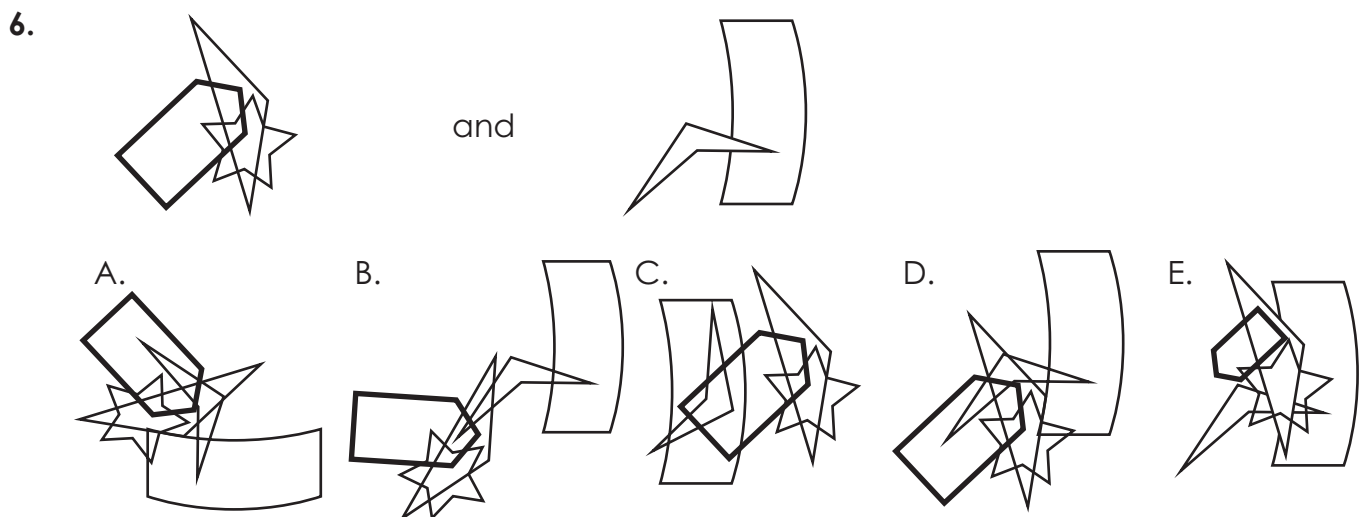





8.



and

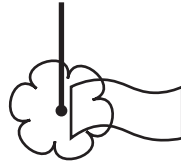

A.

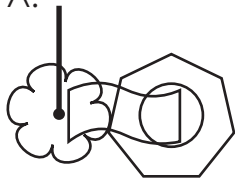

B.

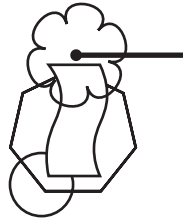

C.

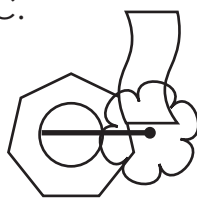

D.



E.

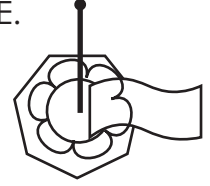

In the questions below, which composite shape is created when all the shapes are joined by the corresponding letters?

9.

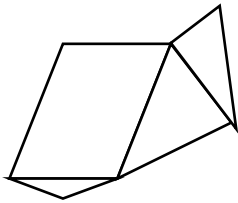
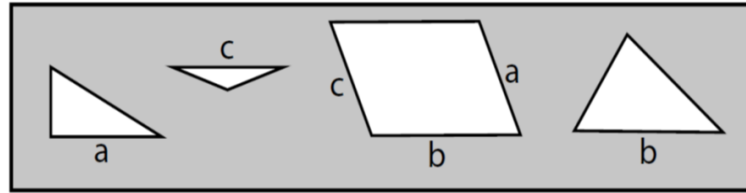

A.

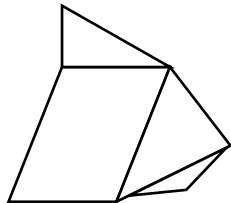

B.

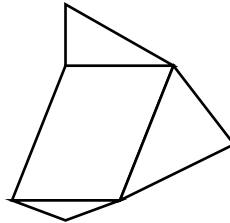

C.

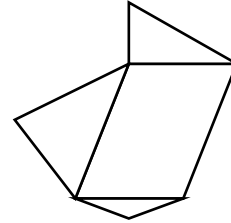

D.

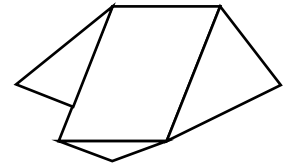

E.

10.

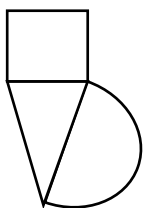
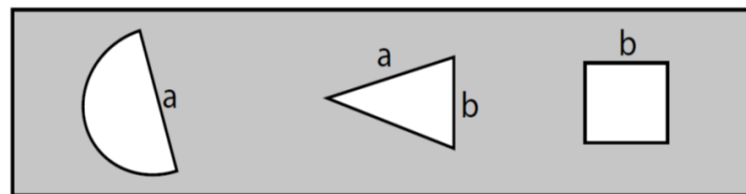

A.

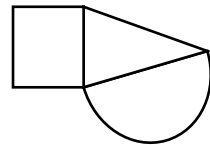

B.

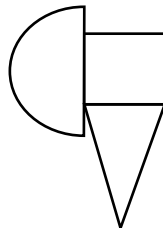

C.

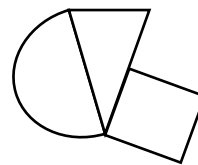

D.

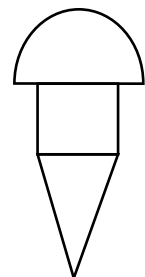

E.





11.

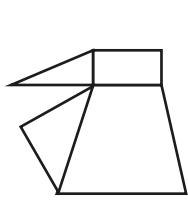
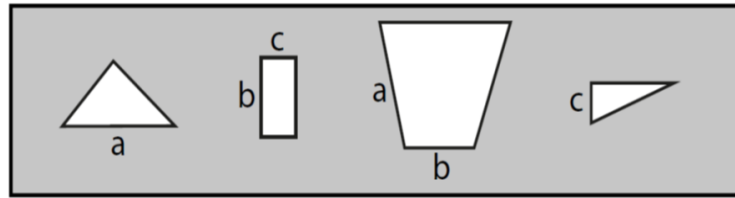

A.

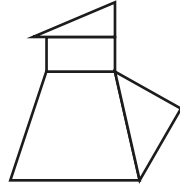

B.

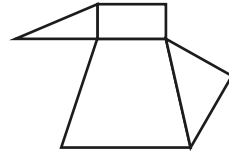

C.

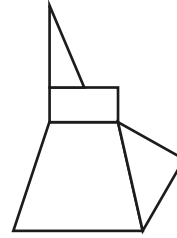

D.

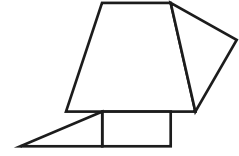

E.

12.

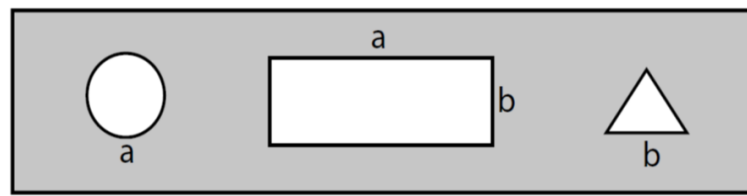

A.

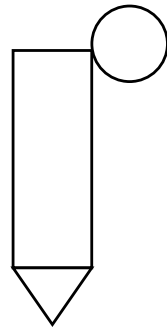

B.

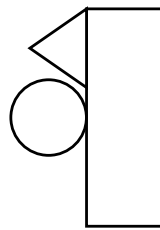

C.

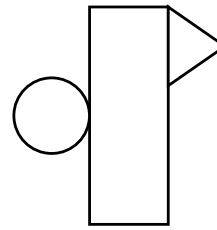

D.

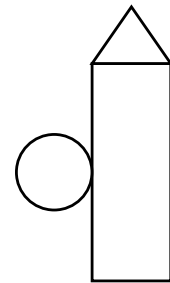

E.

Which option is a plan view of the 3D shape on the left?

13.

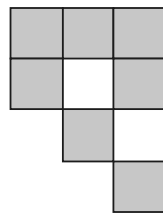
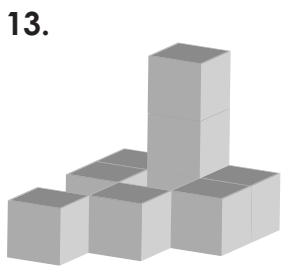

A.

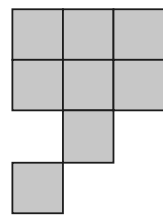

B.

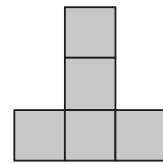

C.

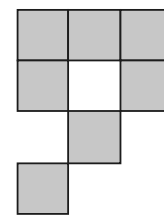

D.

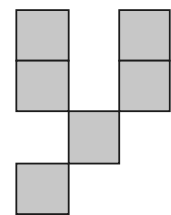

E.

14.

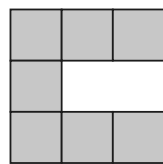
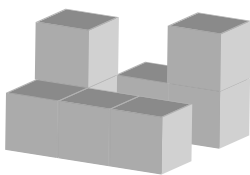

A.

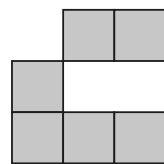

B.



C.

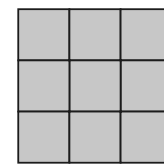

D.

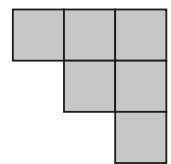

E.





15.

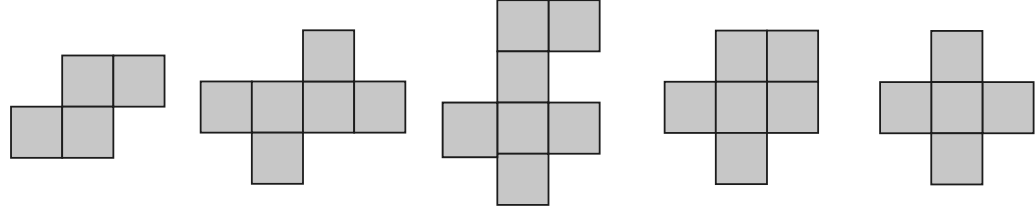
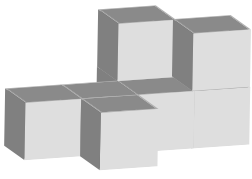

A. B. C. D. E.

16.

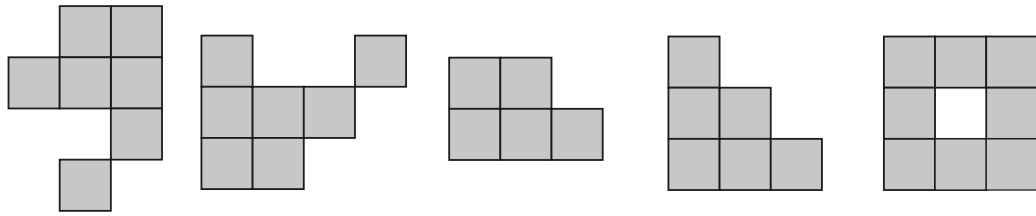
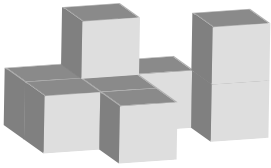

A. B. C. D. E.

Look at the cube on the left. Which net matches the cube?

17.

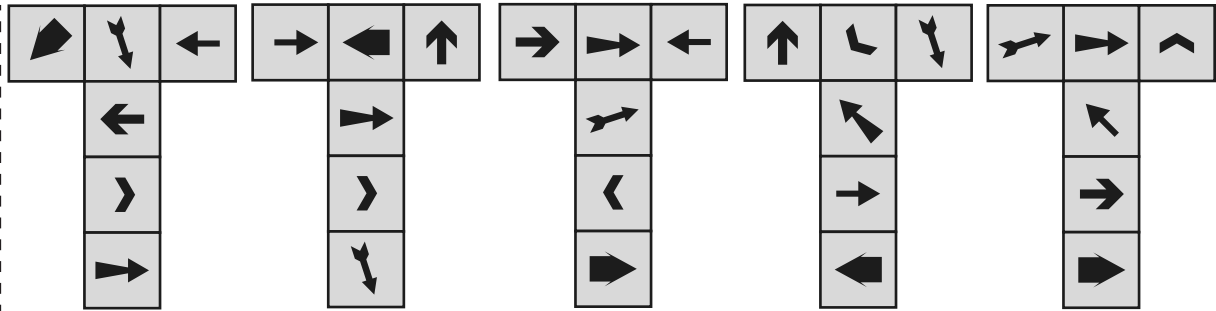
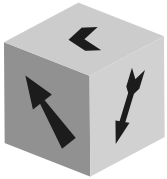

A. B. C. D. E.

18.

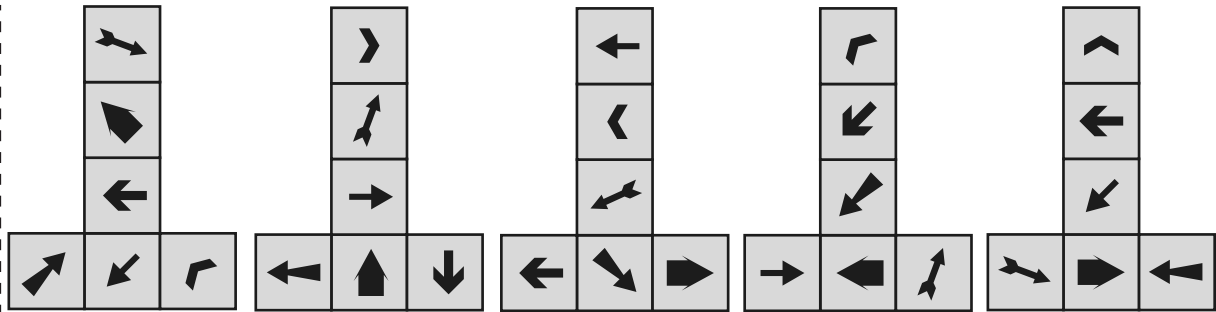
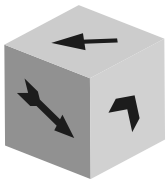

A. B. C. D. E.





19.

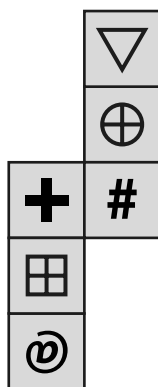

A.

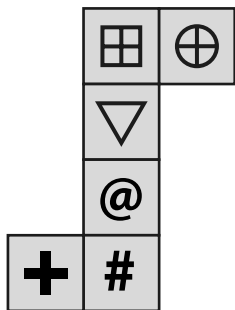

B.

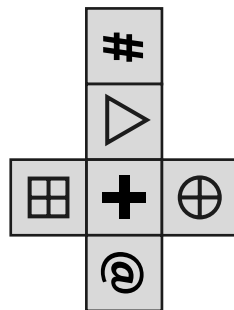

C.

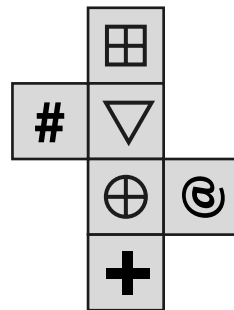

D.

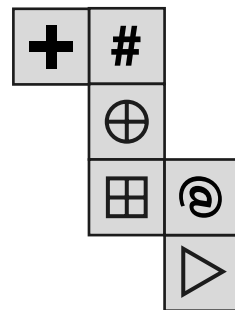

E.

20.

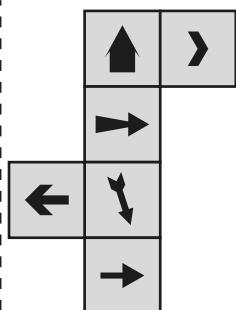
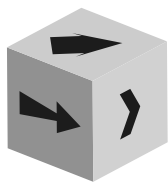

A.

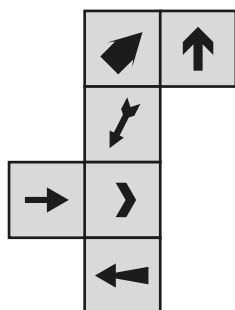

B.

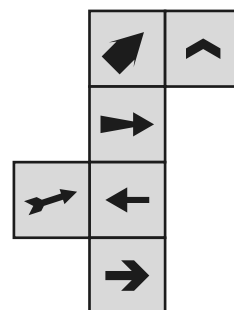

C.

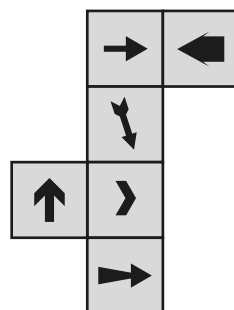

D.

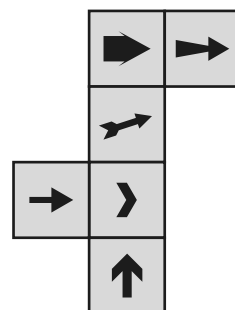

E.

END OF INTERIM PAPER 2 NVR





# SELF REFLECTION

Take some time to reflect on your review test experience. Although they may sometimes feel stressful, exams can also be valuable learning opportunities.

## Your preparation

How confident did you feel going into the exam?



Did you prepare / revise for the test in any way?

---

---

## Your performance

Did you understand and follow the instructions given for the exam?

<input type="checkbox"/>	<input type="checkbox"/>
yes	no

Did you have enough time to answer all the questions in the exam?

<input type="checkbox"/>	<input type="checkbox"/>
yes	no

Which topics were you most confident answering?

---

---

Which topics were you least confident answering?

---

---

What emotions did you feel during the exam?

---

---

## What might you do differently next time?

In preparation for your next exam, write down one thing you will keep doing and one thing you will change for next time.

Keep	Change



## INTERIM TEST 3 – MATHS

- Interim Test 3 – Maths includes 21 questions.
- You have **18 minutes** to complete this test.
- Write your answers on the lines provided or circle the correct answer on your test paper.

1. What is the probability of the spinner landing on a prime number. Write your answer as a fraction in its simplest form.

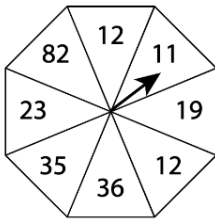

**Answer:** \_\_\_\_\_

2. Imagine a classroom in which each student either completely believes or does not believe at all in the existence of a teapot orbiting around the Sun between Mars and Jupiter, and where the proportion of believers is  $\frac{3}{7}$ . Write the ratio of teapot believers to teapot non-believers in this classroom.

**Answer:** \_\_\_\_\_ : \_\_\_\_\_

3. A class has boys to girls in the ratio of 2:5. There are 12 more girls than boys. How many boys and girls are in the class?

**Answer:** \_\_\_\_\_ boys and \_\_\_\_\_ girls

4. The ratio of red balls to blue balls in a ball pit is 9:4. If there are 20 blue balls, how many red balls will there be?

**Answer:** \_\_\_\_\_

5. What is the probability you will pick a hearts card from a deck of 52 cards, in its simplest form?

**Answer:** \_\_\_\_\_

6. The ratio of blue and red bricks in the Lego box is 4:5. There are 30 red bricks. How many blue bricks are there?

**Answer:** \_\_\_\_\_



7. There are 30 people in a cafe. 10 are children and the others are adults. One person is going to receive a free drink. What is the probability of an adult receiving the free drink?

**Answer:** \_\_\_\_\_

8. A bag contains 5 red marbles, 4 green marbles, and 3 blue marbles. What is the probability of selecting a green marble from the bag?

**Answer:** \_\_\_\_\_

9. The radius of this circle is 46mm. What is the length of AB in mm?

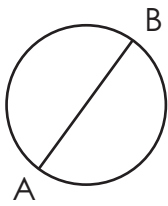

**Answer:** \_\_\_\_\_ mm

10. One of the angles in a right-angled triangle is  $64^\circ$ . What is the size of the smallest angle in degrees?

**Answer:** \_\_\_\_\_ $^\circ$

11. What is the order of rotational symmetry of the shape below?

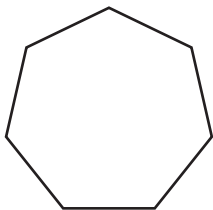

**Answer:** \_\_\_\_\_

12. How many edges does a square-based pyramid have?

**Answer:** \_\_\_\_\_





13. Which 3D shape can be formed from the net below?

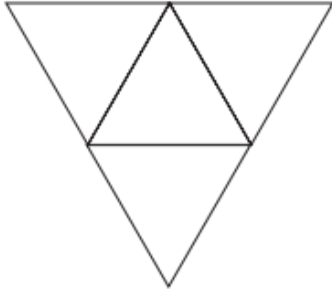

Answer: \_\_\_\_\_

14. Triangle ABC is translated three squares down and two squares left. What are the coordinates of the new position of A?

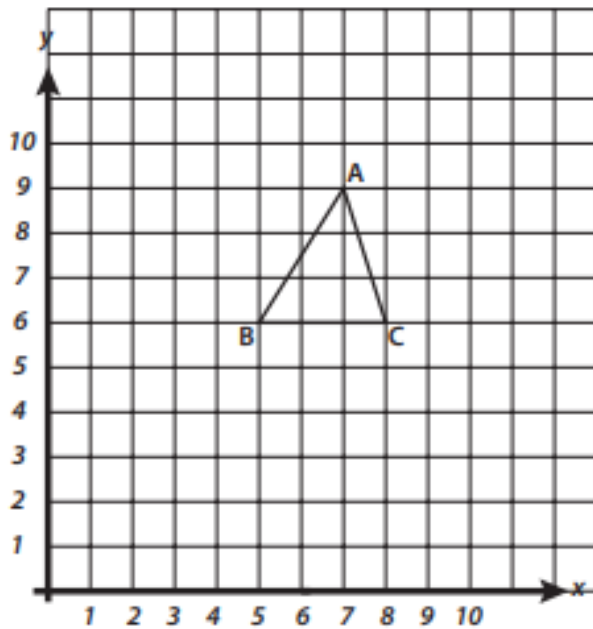

Answer: \_\_\_\_\_

15. If  $a = 6$ ,  $b = 5$  and  $c = 2$        $(4a-3b) + 7c =$

Answer: \_\_\_\_\_





16. A jug contains 1.5 litres of juice. If you pour out 650 millilitres, how much juice is left in the jug?

**Answer:** \_\_\_\_\_ litres

17. The volume of a rectangular box is  $240 \text{ cm}^3$ . Its length is 8cm and its width is 5cm. What is the height of the box?

**Answer:** \_\_\_\_\_ cm

18. What is the volume of the cuboid below?

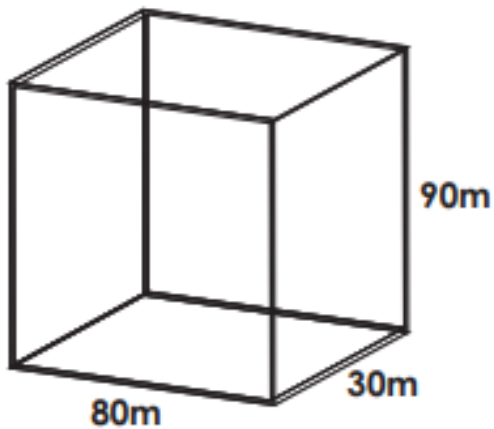

**Answer:** \_\_\_\_\_  $\text{m}^3$

19. Which of these is the next triangular number: **1, 3, 6, 10, 15, 21, ?**

**Answer:** \_\_\_\_\_

20. What is the next number in this sequence: **4, 9, 19, 39, 79, ?**

**Answer:** \_\_\_\_\_

21. What is the next number in this sequence:  **$1 \frac{1}{2}$ ,  $2 \frac{1}{4}$ , 3,  $3 \frac{3}{4}$ ,  $4 \frac{1}{2}$ , ?**

**Answer:** \_\_\_\_\_

**END OF INTERIM PAPER 3 MATHS**



## INTERIM TEST 3 – ENGLISH

- Interim Test 3 – English test includes 15 questions.
- You have **15 minutes** to complete this test.
- Answers should be marked on the answer sheet provided on Page 69, not on the test paper.

**Read the extract then answer the questions that follow.**

### **The Incredible Machine**

Everyone has a favourite attraction at an amusement park, and I am no different. However, unlike most people, who seem to prefer roller coasters, my favourite ride is a little more gentle. Every time I go to an amusement park, I absolutely have to ride the Ferris wheel.

- 5 The Ferris wheel is simple and yet also quite complex. That is, riding it is easy, but how it works is complicated. A series of carts are attached to a wheel, which is attached to a rim. That rim rotates vertically around an axis, and gravity keeps the carts upright. As simple as the ride seems, only advanced engineers can make Ferris wheels that are both safe and fun.

### **What it Lacks in Thrills...**

- 10 While the Ferris wheel is not as thrilling as a roller coaster, it is still very exciting. The fact of being high in the air makes it so much more entertaining than a lot of rides. I mean, how often do you hang that high up in daily life?

Nevertheless, I have to admit, I don't seek Ferris wheels out because of their excitement. Rather, I find them very relaxing. At the top of the Ferris wheel you get beautiful sights of the park. You also get a sense of calm that you don't get in the hustle and bustle of the park below.

### **It Happened at the World's Fair**

- 15 The first Ferris wheel was made by and named after George Washington Gale Ferris, Jr. He designed it for the Chicago World's Fair in 1893. It was the tallest attraction there, standing 264 feet high.

- 20 However, visitors to the fair were impressed by the size of the ride, as well as the mechanics of it. In 1893, anything that was not turned by hand was considered a sight to see. And the wheel, which was a machine, was truly incredible to see. Furthermore, as one visitor put it, the wheel was amazing because it seemed to be missing support. That is, it did not look like it could stand on its own. And yet it did and even rotated!

### **They Keep Reaching Higher and Higher**

Ferris wheel technology has only improved since then. Most of today's Ferris wheels are much larger than that first one. The largest in the world is the "Singapore Flyer", which stands slightly more than twice as tall as George Ferris's wheel.

- 25 Today, the Ferris wheel is the most common amusement park ride. But that does not mean you should take them for granted. Instead, be thankful for Ferris's invention. The next time you're at an amusement park, don't just look up at the impressive wheel in the sky on your way to a newer attraction, take it for a spin!





1. Choose a synonym for the word 'attraction'. (Line 1)
  - A sense
  - B park
  - C ride
  - D vision
  - E appeal
  
2. Choose the best antonym for the word 'complex'. (Line 4)
  - A impressive
  - B beautiful
  - C exciting
  - D simple
  - E intricate
  
3. What does the author like best about Ferris wheels?
  - A The impressive engineering and beauty of them.
  - B The excitement and thrills they guarantee.
  - C The beautiful sights and relaxation they allow.
  - D The fact that most amusement parks have one.
  - E They were designed as much to be seen as to be ridden.
  
4. The passage was most likely written to:
  - A Describe the author's favourite amusement park rides.
  - B Explain the original design of Ferris wheels and how they work today.
  - C Describe the history of Ferris wheels and why they are so popular.
  - D Inform the reader where they can find Ferris wheels.
  - E Explain the history of Ferris wheels and why the author likes them.





5. According to the information in the passage, how tall is the tallest Ferris wheel in the world?

---

6. What does the heading: **'They Keep Reaching Higher and Higher'** suggest?

---

---

7. What does the author advise you to do at the end of the passage?

---

---

### Spelling: Silent Letters

The words below each have a silent letter in them. Write the silent letter on the line provided.

8. scenery

---

9. design

---

### Metaphors & Personification

In the questions below, the sentences contain either a metaphor or personification. Choose the best explanation for the metaphor or personification. If there is no metaphor or personification, choose N.

10. He is a shining star.

- A. He has very shiny skin.
- B. His clothes glow in the dark.
- C. He is very polite and positive.
- D. He is misbehaving and rude.
- N. No metaphor or personification.



11. The light danced on the surface of the water.

A. The sunlight is reflecting off the water, making it sparkle.

B. The sun is having dance lessons in the water.

C. The light is plunging into the water and making it bright.

D. The light is making the water rough and choppy.

N. No metaphor or personification.

### Grammar

Identify the part of the sentence that contains the **object**. If there is no object, choose N.

12. Joe played his first game of rugby since breaking his arm.

A	B	C	D	N
---	---	---	---	---

Identify the part of the sentence that contains the **subordinate clause**. If there is no subordinate clause, choose N.

13. On sports day Freddie won a medal for the race although he didn't win.

A	B	C	D	N
---	---	---	---	---

Identify the part of the sentence that contains the **adverbial**. If there is no adverbial, choose N.

14. Bobbi eats toast and jam for their breakfast every day.

A	B	C	D	N
---	---	---	---	---

Identify the part of the sentence that contains the **relative pronoun**. If there is no relative pronoun, choose N.

15. Can you take me to gymnastics, which is in the next village?

A	B	C	D	N
---	---	---	---	---

END OF INTERIM PAPER 3 ENGLISH



## INTERIM TEST 3 – VR

- Interim Test 3 – VR test includes 20 questions.
- You have **10 minutes** to complete this test.
- Circle the correct answer on your test paper.

There are three pairs of words. Complete the third pair so they have the same connection as the first two pairs.

1. (eager, age) (start, tar) (tower, \_\_\_\_\_)

- A. owe      B. tow      C. row      D. too      E. rot

2. (robust, sob) (rather, eat) (beasts, \_\_\_\_\_)

- A. bat      B. tab      C. tea      D. set      E. beat

A four-letter word is hidden at the end of one word and the beginning of the next word in the sentence. Find the pair of words that contains the hidden word.

3. The local milkman is very busy.

- A. The local      B. local milkman      C. milkman is      D. is very      E. very busy

The three words in the second group should go together in the same way as the three in the first group. Choose the missing word.

4. agency (change) banish / entity (\_\_\_\_) enable

- A. ninety      B. talent      C. tenant      D. neaten      E. niblet

Find the number that will complete the sum correctly.

5.  $33 \div 11 + 15 = 56 - (\text{____})$

- A. 36      B. 38      C. 34      D. 37      E. 39

The three numbers in each group are related to each other in the same way as the other two groups. Find the number that completes the last group.

6. (3, [10], 1) (2, [11], 5) (3, [ ], 4)

- A. 11                      B. 12                      C. 14                      D. 7                      E. 13

7. (6, [10], 14) (12, [17], 22) (9, [ ], 23)

- A. 14                      B. 16                      C. 32                      D. 18                      E. 7

8. (2, [8], 2) (3, [9], 1) (1, [ ], 6)

- A. 12                      B. 7                      C. 5                      D. 8                      E. 6

In each question, there are two pairs of words. You must select a word from the options below that will go equally well with both pairs.

9. (perfume, scent) (anger, infuriate)

- A. smell                      B. crazy                      C. floral                      D. fragrance                      E. incense

The words below are a jumbled sentence with one extra word. Identify the superfluous word from the sentence.

10. peanut toast one I butter on my like

- A. peanut                      B. toast                      C. one                      D. butter                      E. like

11. moor pouring ran mud the I rain over the in

- A. moor                      B. pouring                      C. ran                      D. mud                      E. over

12. read had I time I music to wish more

- A. read                      B. had                      C. time                      D. music                      E. more

Two words have had one letter removed and their remaining letters mixed up. The same letter has been removed from both words. Unscramble the letters and work out which letter is missing.

13. The atrwe kept the tips from their htfs at the restaurant.

- A. i                      B. e                      C. w                      D. d                      E. v



14. If we bniome the ingredients we will be able to make the aesk.

- A. e                      B. c                      C. b                      D. s                      E. m

The alphabet is given to help you. Find the pair of letters that continues the series in the most sensible way. Choose one pair from the answers below.

**A B C D E F G H I J K L M N O P Q R S T U V W X Y Z**

15. AE BF CG DH EI

- A. SB                      B. FG                      C. GH                      D. AR                      E. FJ

16. AC DD GF JI MM

- A. PR                      B. MO                      C. NN                      D. ON                      E. PQ

**Three** of the **five** words listed below are related in some way. Find the **two** words that do not go with these three.

17. (calf, cow, puppy, dog, kitten)

- A. calf                      B. cow                      C. puppy                      D. dog                      E. kitten

**A B C D E F G H I J K L M N O P Q R S T U V W X Y Z**

18. If the code for MEANT is JCBQX, what does BYUHR mean?

- A. AGENT                      B. EATEN                      C. TAKEN                      D. TALES                      E. ENACT

19. If MGEAX means LEASH, what does XJETU mean?

- A. WHILE                      B. WHEEL                      C. WHALE                      D. WHOLE                      E. WELSH

20. There are four words below and only three codes provided. Three of the four words are given in code. The codes are not written in the same order as the words. What is the word for the code 16432?

- |          |          |          |          |
|----------|----------|----------|----------|
| AMUSE    | PAUSE    | CAUSE    | SPACE    |
| 15632    | 36412    | 56412    |          |
| A. CASES | B. PAINT | C. LONER | D. PEACH |
|          |          |          | E. SAUCE |

**END OF INTERIM PAPER 3 VR**







# INTERIM TEST 3 – NVR

- Interim Test 3 – NVR test includes 10 questions.
- You have **5 minutes** to complete this test.
- Circle the correct answer on your test paper.

Look at the folded piece of paper with holes punched in it. Which option shows what the paper will look like when it is unfolded?

1.

A

B

C

D

E

2.

A

B

C

D

E





3.

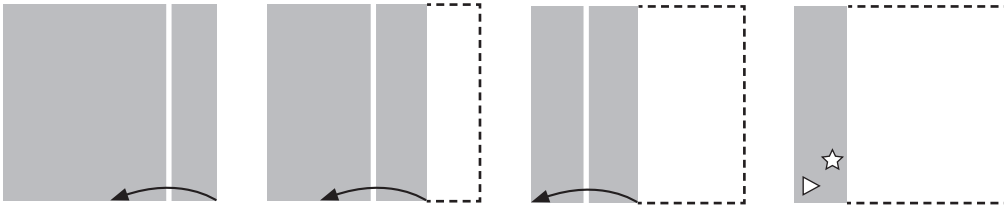

A

B

C

D

E

4.

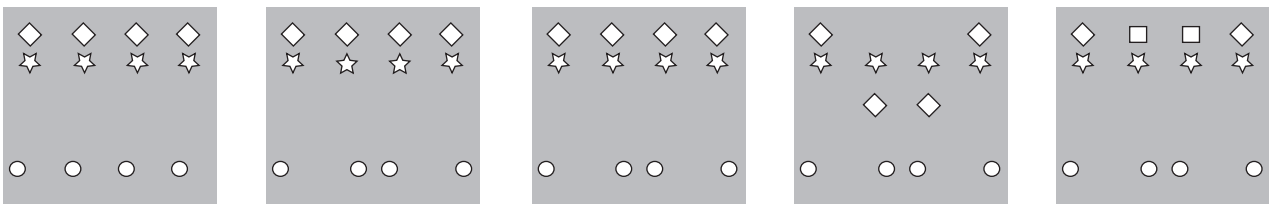
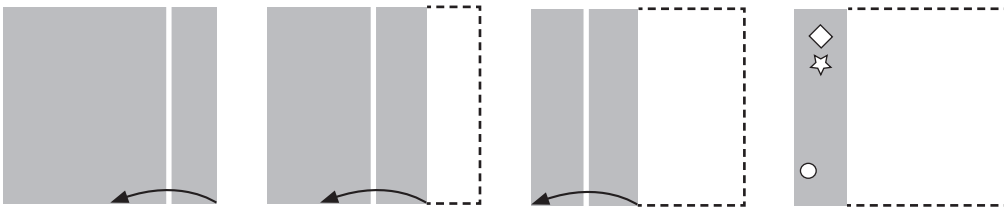

A

B

C

D

E

In the questions below, look at the shape on the left. Identify the identical shape on the right.

5.

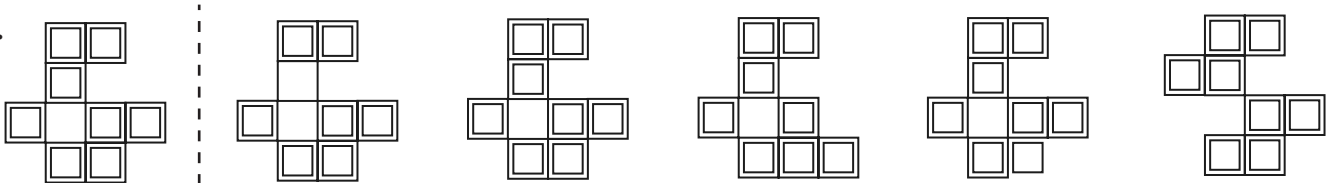

A

B

C

D

E

6.

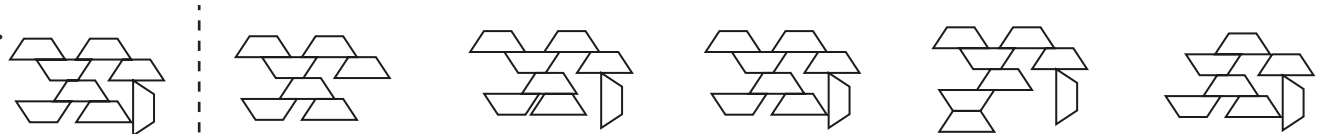

A

B

C

D

E

7.

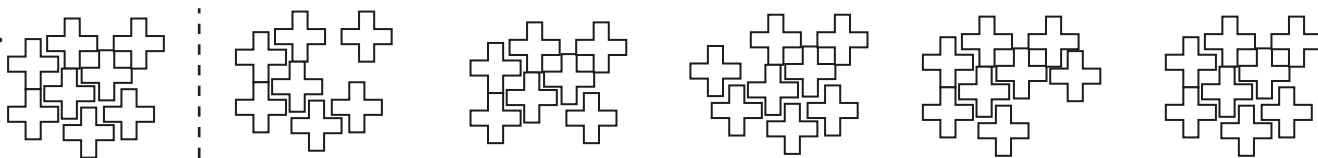

A

B

C

D

E





8. Which shape in Group 2 corresponds to shape number 3 from Group 1?

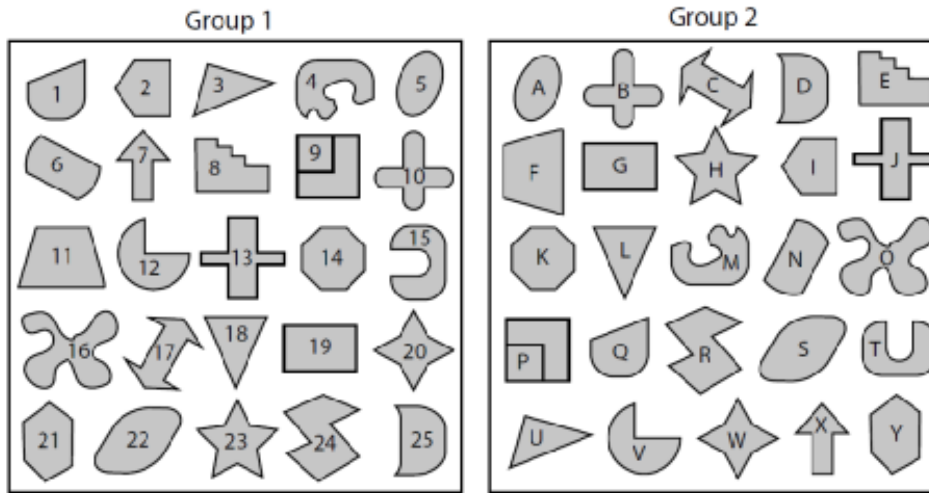

- A. Y      B. L      C. U      D. J      E. D

9. Which shape in Group 2 corresponds to shape number 21 from Group 1?

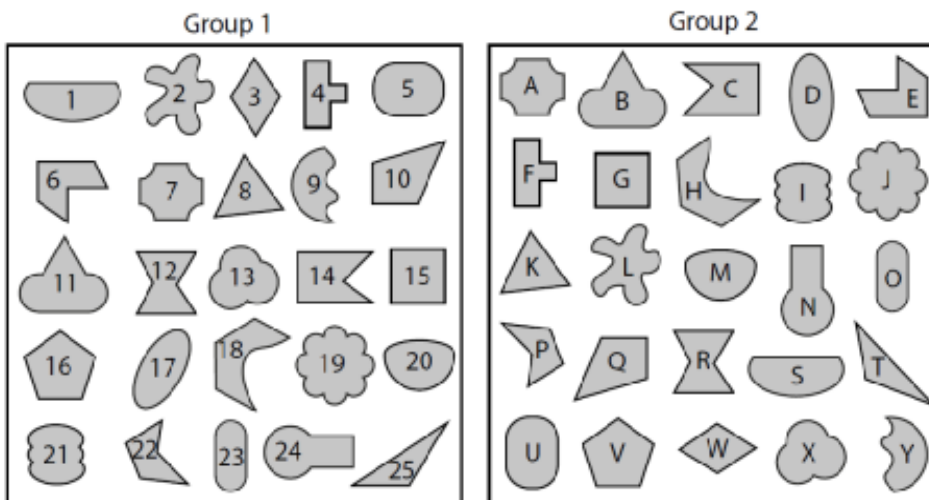

- A. I      B. J      C. L      D. X      E. Y

10. Which shape in Group 2 corresponds to shape number 14 from Group 1?

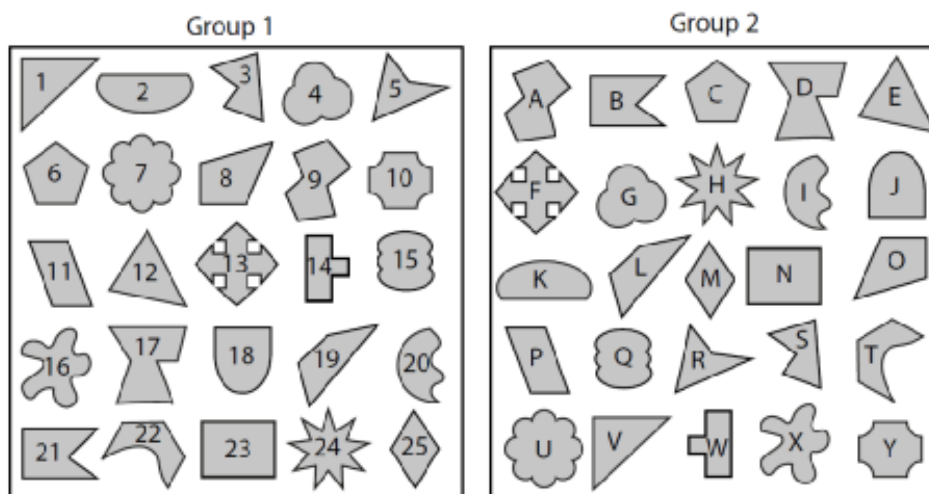

- A. R      B. F      C. I      D. W      E. T





In the questions below, which composite shape is created when all the shapes are joined by the corresponding letters?

11.

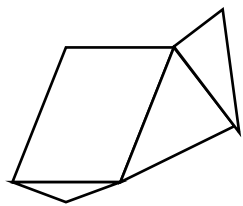
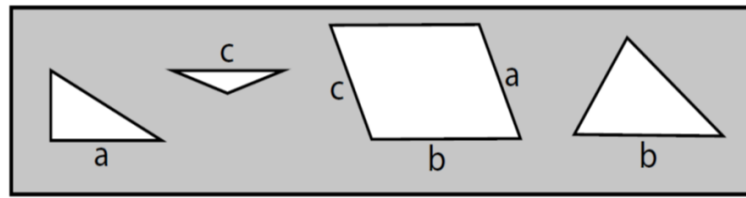

A.

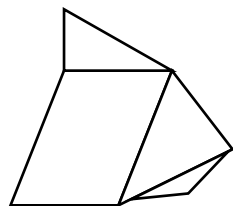

B.

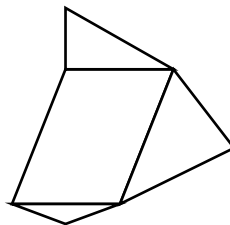

C.

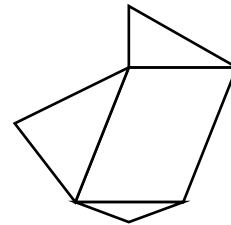

D.

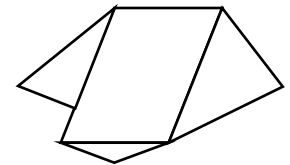

E.

12.

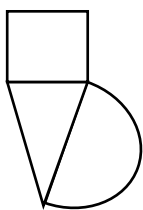
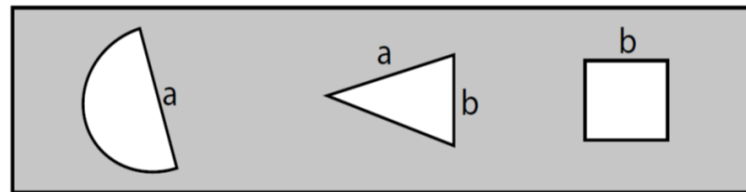

A.

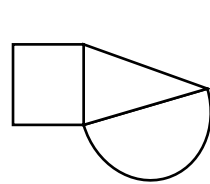

B.

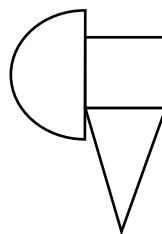

C.

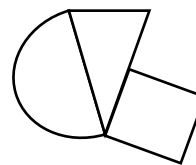

D.

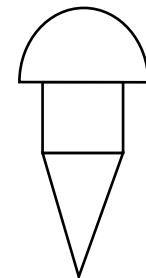

E.

13.

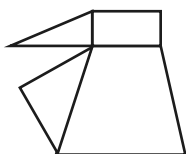
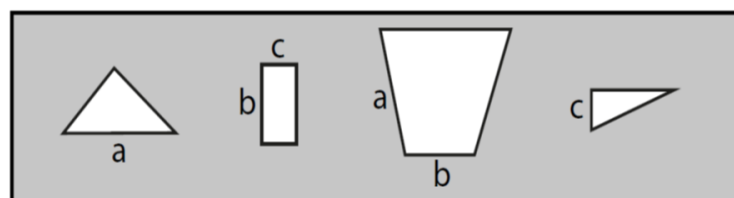

A.

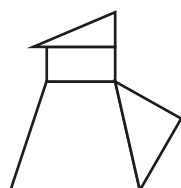

B.

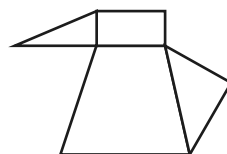

C.

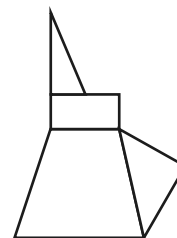

D.

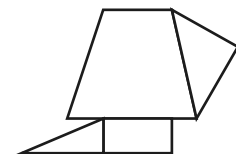

E.





14.

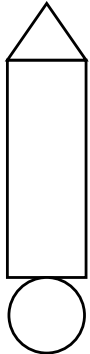
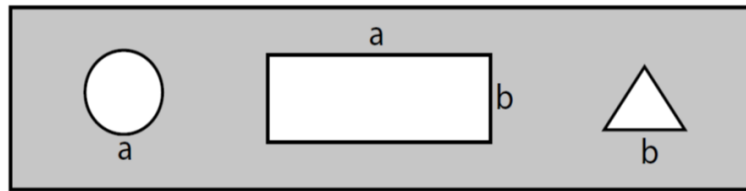

A.

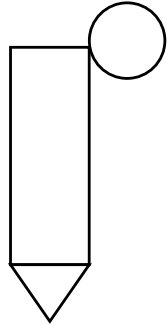

B.

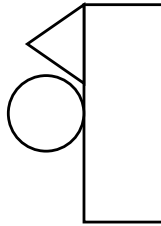

C.

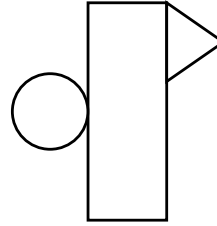

D.

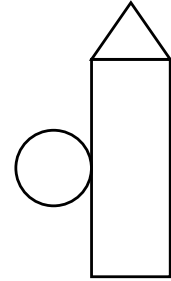

E.

On the left of each question, there are five triangles arranged in order. One of these triangles has been left empty.

Decide which of the five triangles on the right should take the place of the empty triangle.

15.



A



B



C



D



E

16.

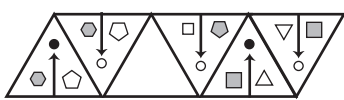

A



B



C



D



E

17.

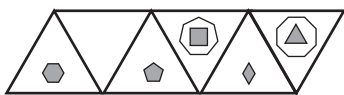

A

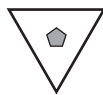

B



C



D



E





In each question, there are two large triangles, each made up of four small triangles. One of the small triangles has been left empty.

Decide which of the five figures should fill the empty triangle.

18.

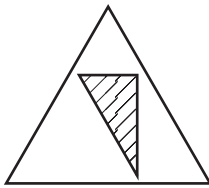
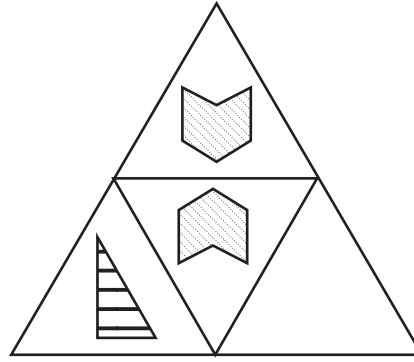
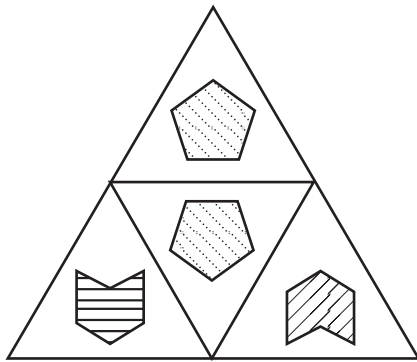

A

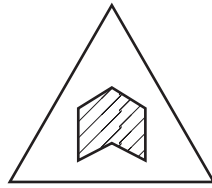

B

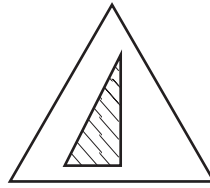

C

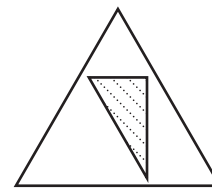

D

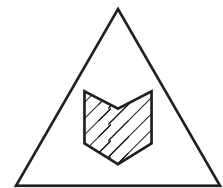

E

19.

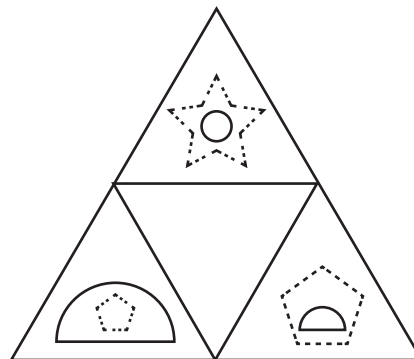
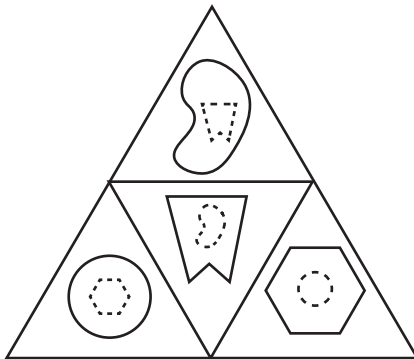

A

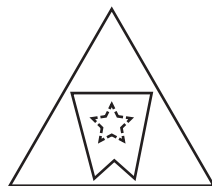

B



C

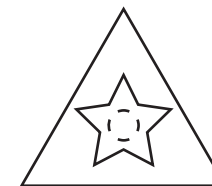

D

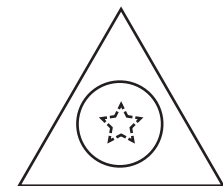

E





20.

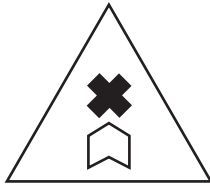
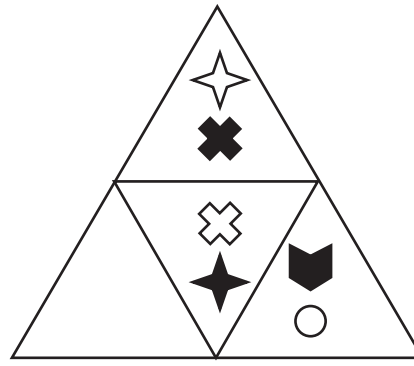
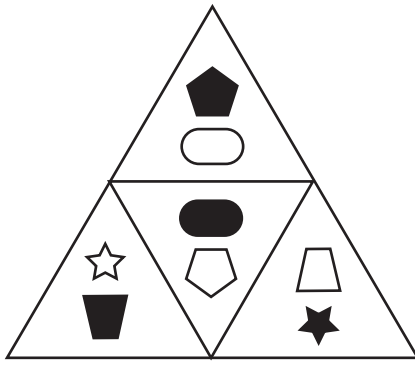

A

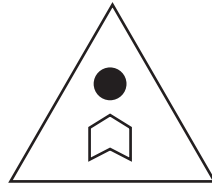

B

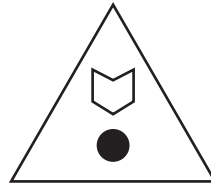

C

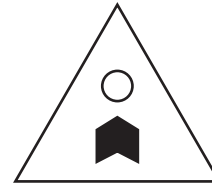

D

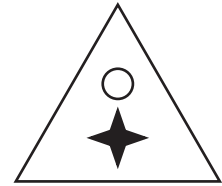

E

END OF INTERIM PAPER 3 NVR





# SELF REFLECTION

Take some time to reflect on your review test experience. Although they may sometimes feel stressful, exams can also be valuable learning opportunities.

## Your preparation

How confident did you feel going into the exam?



Did you prepare / revise for the test in any way?

---

---

## Your performance

Did you understand and follow the instructions given for the exam?

<input type="checkbox"/>	<input type="checkbox"/>
yes	no

Did you have enough time to answer all the questions in the exam?

<input type="checkbox"/>	<input type="checkbox"/>
yes	no

Which topics were you most confident answering?

---

---

Which topics were you least confident answering?

---

---

What emotions did you feel during the exam?

---

---

## What might you do differently next time?

In preparation for your next exam, write down one thing you will keep doing and one thing you will change for next time.

Keep	Change



# Mock Paper A – Maths

**Read the instructions carefully.**

1. Write your answer for each question on the line provided, or circle the correct answer when you are given answer options.
2. You will have **50 minutes to answer 50 questions**.
3. You may find some of the questions difficult. If you cannot do a question, do not waste time on it, but go on to the next questions. If you are not sure of an answer, choose the one you think is best.
4. Work as quickly and as carefully as you can.
5. Make sure you can see a clock.
6. Allocate enough time to check your answers at the end.

1. Mr Wiggin's supermarket bill is £22.38. At the checkout the bill is reduced by £1.77 by using a voucher. What is the new amount he has to pay?

**Answer:** £ \_\_\_\_\_

2. Which number is divisible by both 6 and 9?

**Answer:** \_\_\_\_\_

3. Look at this thermometer. What temperature does the arrow point to in Celsius?

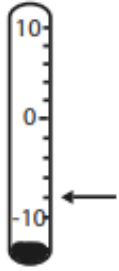

**Answer:** \_\_\_\_\_°

4. On Tuesday night at 7pm there were 167 people in the Olympiad Sports Hall. 102 people came by car. The rest walked or got the bus. How many walked or got the bus in total?

**Answer:** \_\_\_\_\_

5. Light bulbs cost 79p each. How much will 6 light bulbs cost?

**Answer:** £ \_\_\_\_\_

6. Which of the letters below has 2 lines of symmetry?

A. S

B. A

C. T

D. X

E. N

7. Laura is decorating cupcakes. She needs 36 chocolate sprinkles per cupcake. How many sprinkles does she need for 100 cupcakes?

**Answer:** \_\_\_\_\_

8. The local library is moving into a new building. Each packing box holds 80 books. They have 780 books in the non-fiction section. How many boxes will they need?

**Answer:** \_\_\_\_\_

9. Chandni has one £2 coin, two £1 coins, three 50 pence coins, four 5 pence coins and three pennies. How much money does she have altogether?

**Answer:** \_\_\_\_\_

10. What is the numeral for eight hundred and seventy-two thousand?

**Answer:** \_\_\_\_\_

11. What is  $4^3$  equivalent to?

- A.  $4 \times 3$       B.  $3 \times 3 \times 3 \times 3$       C.  $4 \times 4 \times 4$       D. 100      E.  $4 \times 3 \times 3$

12. At a pie-eating contest, each of the 9 contestants ate  $\frac{1}{3}$  of a huge pie each. How many pies were eaten in total?

**Answer:** \_\_\_\_\_

13. Complete the sequence: 12, 24, \_\_\_\_, 48, 60, 72.

**Answer:** \_\_\_\_\_

As part of a school's safety campaign, children in a class were asked how they got to school.

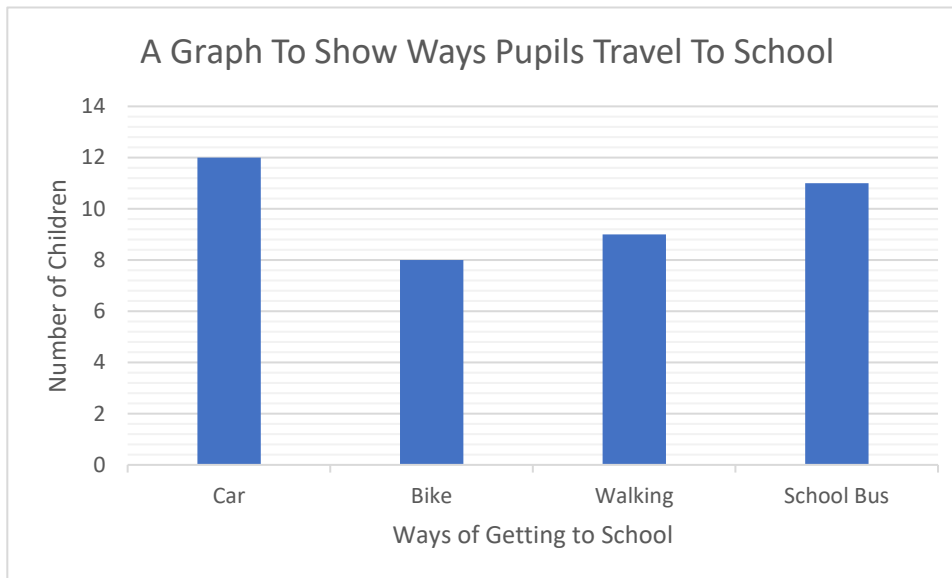

14. How many children got the school bus?

**Answer:** \_\_\_\_\_

15. What was the total number of children surveyed?

**Answer:** \_\_\_\_\_

16. When surveyed the following year, double the amount of children walked to school. How many children is that?

**Answer:** \_\_\_\_\_

17. When every box is filled in on this grid, each row, each column and each diagonal adds up to 15. Which number should be in the box with the question mark?

2	9	4
	1	?

Answer: \_\_\_\_\_

18. Give the coordinates of point A on the grid below

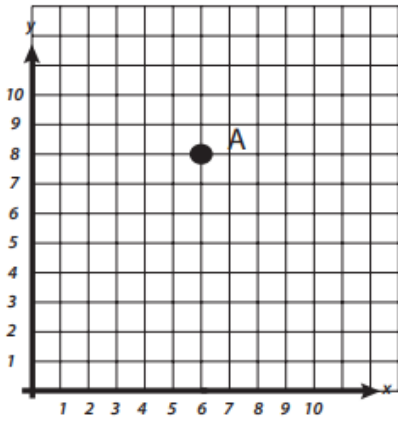

Answer: \_\_\_\_\_

19. What number is shown on the number line below?

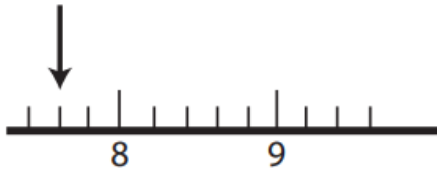

Answer: \_\_\_\_\_

20. These are the months of the year:

January	February	March	April
May	June	July	August
September	October	November	December

What fraction of the months end with the letter Y? Write your answer in its simplest form.

Answer: \_\_\_\_\_

Use the graph below to answer questions 21 and 22.

Plot and name the coordinates: A (2,2) B (4,5) C (7,5) D (9,2). Join the points.

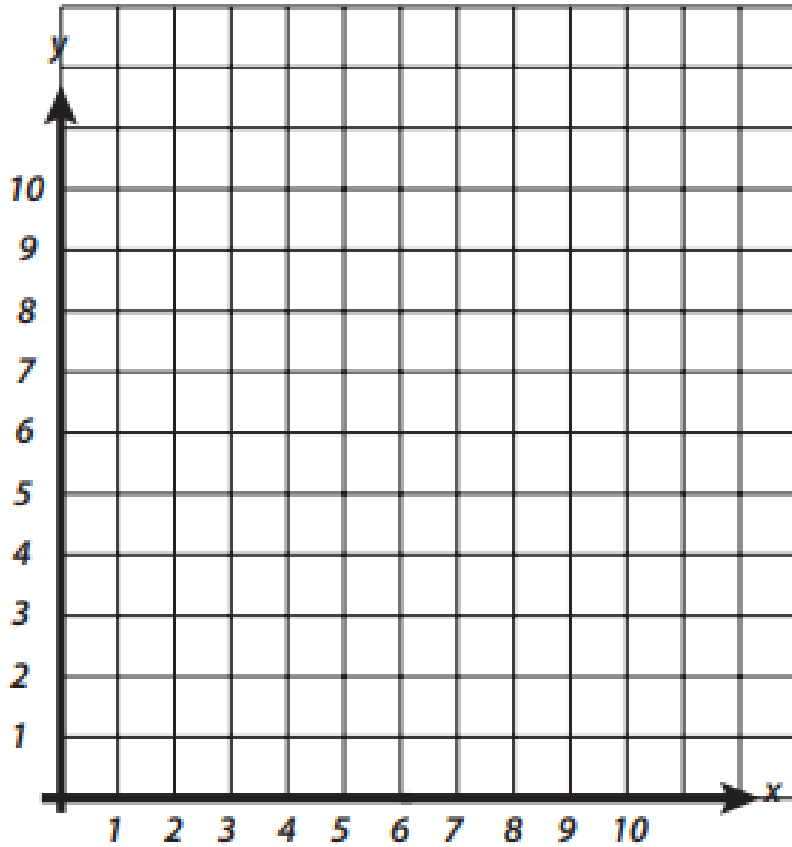

21. What is the name of the shape you have drawn?

**Answer:** \_\_\_\_\_

22. Which of the following statements is correct about the shape you have just drawn?

A. Line AB is perpendicular to Line CD.

B. Line AD is parallel to Line BC.

C. Line AD is perpendicular to Line BC.

D. Line AB is a horizontal line.

E. Line BC is the same length as Line AD.

23. 200 families visit an adventure park.  $\frac{2}{5}$  of them pay by card. How many families is that?

**Answer:** \_\_\_\_\_



24. What is the perimeter of the shape below?

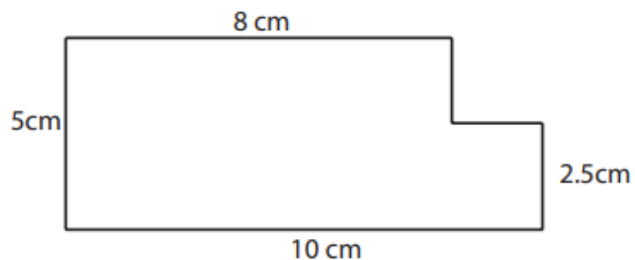

Answer: \_\_\_\_\_ cm

25. What is the area of the shape above?

Answer: \_\_\_\_\_ cm<sup>2</sup>

26. Complete the function machine below

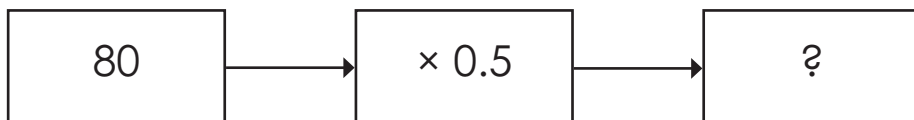

Answer: \_\_\_\_\_

27. How many faces and edges does this cube have?

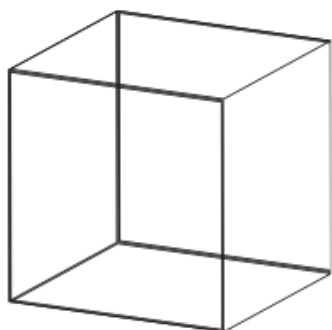

- A. 4 faces, 8 edges.
- B. 6 faces, 12 edges.
- C. 8 faces, 12 edges.
- D. 6 faces, 10 edges.
- E. 6 faces, 14 edges.



28. Abi, Belinda, Carol and Diane are all sisters. Diane is the eldest by 2 years and is also double the age of Belinda, the youngest sister. Carol is 10, which is 4 years older than Belinda. Abi is 7. Which statement is true?

- A. Diane is the youngest.
- B. Belinda is older than Abi.
- C. Diane is 12 years old.
- D. Abi is 10.
- E. Carol is 4 years old.

29. The image below is the net for which shape?

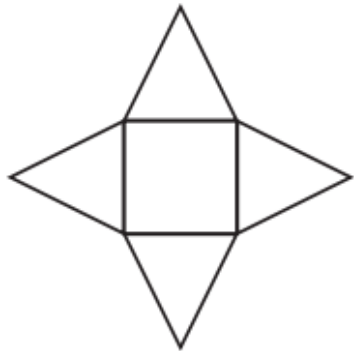

Answer: \_\_\_\_\_

30. Which shape does not have reflectional symmetry?

- A.
- B.
- C.
- D.
- E.

31. Which of these numbers is not a multiple of 7?

- A. 35
- B. 84
- C. 62
- D. 77
- E. 21

32. Solve the equation:  $5x + y = z$     $z = 110$     $y = 10$     $x = ?$

Answer: \_\_\_\_\_



33. Which is the equivalent ratio to 3:36?

- A. 2:10      B. 1:18      C. 6:60      D. 4:5      E. 1:12

34. Which has the largest value?

- A. 10% of 100      B. 90% of 40      C. 25% of 80      D. 75% of 60      E. 20% of 50

Use the image below to answer questions 35 and 36.

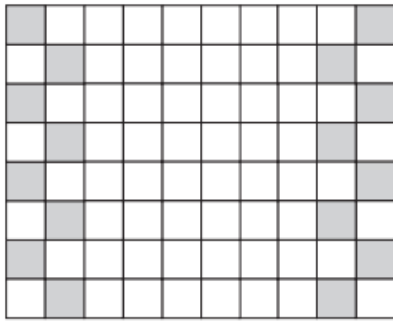

35. What is the area of the whole shape above?

**Answer:** \_\_\_\_\_ cm<sup>2</sup>

36. What percentage of the shape above is shaded grey?

**Answer:** \_\_\_\_\_

37. The product of two numbers is 44. The difference between the two numbers is 20. What are the two numbers?

**Answer:** \_\_\_\_\_

38. The table below shows the number of miles covered each day on a walking tour of the Scottish Highlands.

Day	Number of miles
Mon	?
Tues	6
Wed	6
Thurs	5
Fri	6
Sat	4
Sun	3

The mean is 5. The mode is 6. How many miles did they walk on Monday?

**Answer:** \_\_\_\_\_





39. Complete the following equation.

$$25 \times 5 - 20 = 10 \times y + 5 \quad y =$$

**Answer:** \_\_\_\_\_

40. Approximately how much water would you need to fill an average bath?

- A. 8,000 centilitres      B. 800 litres      C. 80 litres      D. 8,000 litres      E. 8,000 millilitres

Below are the results of a group in a science test.

77%	45%	66%	75%	90%	81%	69%	88%
-----	-----	-----	-----	-----	-----	-----	-----

41. What is the range of the results shown?

**Answer:** \_\_\_\_\_

42. If the pass mark for the group above is 70%, what fraction of the group passed the test?

**Answer:** \_\_\_\_\_

43. Cups cost £2.25 and spoons cost £0.50. How much will Jasleen need to pay altogether to get 8 of each?

**Answer:** £ \_\_\_\_\_

44. Which of the numbers below has the lowest value?

- A. 82.35      B. 82.035      C. 82.305      D. 82.005      E. 82.03

45. The temperature yesterday lunchtime was 4°C. Last night at its coldest point the temperature had fallen by 11°C. What was the lowest temperature last night?

**Answer:** \_\_\_\_\_

46. There are 640 scouts in the town of Gwentle.  $\frac{5}{8}$  of the scouts have camped out at night. How many of the scouts haven't?

**Answer:** \_\_\_\_\_

47. A bus due to arrive at 10:20a.m. is 14 minutes late on Monday. The bus arrives a further 14 minutes late per day. What time does the bus arrive on Friday?

**Answer:** \_\_\_\_\_

48. If you are facing NE and you turn  $90^\circ$  clockwise, in which direction are you facing now?

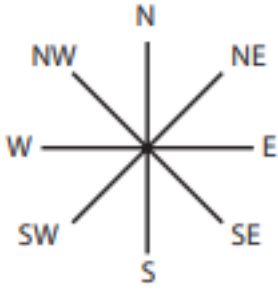

Answer: \_\_\_\_\_

49. What is the square root of 64?

Answer: \_\_\_\_\_

50. The parallelogram below has two angles marked. If  $x$  measures  $125^\circ$ , what is the size of angle  $y$ ?

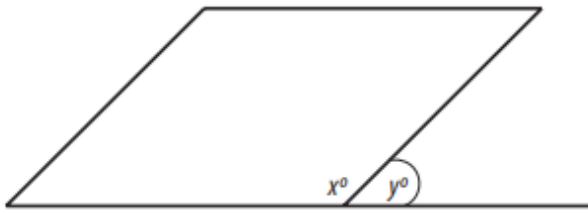

Answer: \_\_\_\_\_

END OF TEST



# SELF REFLECTION

Take some time to reflect on your review test experience. Although they may sometimes feel stressful, exams can also be valuable learning opportunities.

## Your preparation

How confident did you feel going into the exam?



Did you prepare / revise for the test in any way?

---

---

## Your performance

Did you understand and follow the instructions given for the exam?

<input type="checkbox"/>	<input type="checkbox"/>
yes	no

Did you have enough time to answer all the questions in the exam?

<input type="checkbox"/>	<input type="checkbox"/>
yes	no

Which topics were you most confident answering?

---

---

Which topics were you least confident answering?

---

---

What emotions did you feel during the exam?

---

---

## What might you do differently next time?

In preparation for your next exam, write down one thing you will keep doing and one thing you will change for next time.

Keep	Change

# Mock Paper A – English

## Read the instructions carefully.

1. You have a passage to read and then answer some questions about it. You can look back at the passage to check your answers as many times as you want.
2. There are three sections of spelling, punctuation and grammar exercises to do.
3. Write your answer for each question on the line provided, or circle the correct answer when you are given answer options.
4. You have **50 minutes to answer 56 questions**.
5. You may find some of the questions difficult. If you cannot do a question, do not waste time on it, but go on to the next questions. If you are not sure of an answer, choose the one you think is best.
6. Work as quickly and as carefully as you can.
7. Make sure you can see a clock.
8. Allocate enough time to check your answers at the end.

Read the extract then answer the questions that follow.

### Schools' Step-By-Step Guide to Fairtrade

Fairtrade is a way of buying and selling products that helps make the world a better place. It is a system that ensures that the people who produce the products we buy are treated fairly. It started in the 1960s when people became concerned about the way farmers and workers were being treated in developing countries. Fairtrade helps these farmers and workers get a fair price for their products, so they can have better working conditions and a better life for themselves and their families. When a product is labeled as 'Fairtrade', it means that the farmers or workers who produced it were paid a fair price for their work. This price is determined by the Fairtrade organisation, and it takes into account the cost of living in that country. Fairtrade also ensures that the workers have safe working conditions and that they are not being exploited. According to the Fairtrade Foundation's annual report for 2019–2020, sales of Fairtrade products in the UK reached £1.7 billion, representing a 20% increase from the previous year. We've made a great start towards a better trade system for farmers in the developing world. But we've still got a long way to go, and we need more people to come with us in making the small steps towards a fairer world.

### The World's Biggest Fairtrade Breakfast

Did you know that your breakfast has travelled a long way before it reaches your plate? Every year, people all over the world come together to celebrate Fairtrade by participating in the 'World's Biggest Fairtrade Breakfast'. This event is a way for people to enjoy a delicious breakfast while supporting Fairtrade products. By participating in this event, people can show their support for Fairtrade and help raise awareness about the importance of fair trade practices. World Fair Trade Day is the annual celebration for the whole Fairtrade movement internationally and is held on the second Saturday in May every year. We will be taking part in the World's Biggest Fairtrade Breakfast and we hope you will too! Start your day of Fairtrade as soon as you get up, with as many Fairtrade products as possible for breakfast! You could include products such as Fairtrade certified coffee, tea, sugar, juice, jams, chocolate spread and honey.

### Fairtrade in School

Fairtrade is not only important for farmers and workers in developing countries but also for students like you! Many schools across the world have become Fairtrade schools, which means they have made a commitment to support Fairtrade products. By supporting Fairtrade in schools, students can help promote fairness, social responsibility and sustainable farming practices. School uniforms are a requirement for many students around the world, but have you ever thought about where they come from? By choosing to buy Fairtrade school uniforms, we can ensure that the cotton used to make them was produced in a fair and sustainable way. Cotton is one of the most widely traded commodities in the world, but cotton farmers often face challenges in getting a fair price for their products. Many cotton farmers live in developing countries and approximately 75% live in poverty. Fairtrade helps cotton farmers to reduce their environmental impact and increase their yields. Due to the high demand for Fairtrade cotton, its cultivation uses about 50% of all chemical pesticides used in agriculture.

Some schools have even made a commitment to use Fairtrade uniforms, helping to create a more socially responsible and sustainable learning environment for students. School uniforms with Fairtrade cotton are now in many stores. But we can do more:

- Make a display about the difference Fairtrade makes to the lives of producers. Put it somewhere prominent so students, staff, parents / carers and visitors can see it.
- Ask your local uniform shop or retailer to stock Fairtrade cotton uniforms.
- Show them your school is interested in Fairtrade. You could do this with letters, a visit or even a presentation, to explain to them what Fairtrade means and how important it is to you.



## Section 1

1. What is Fairtrade?
  - A A type of clothing brand.
  - B A sustainable farming practice.
  - C A movement promoting ethical trade.
  - D A type of coffee.
  - E A type of chocolate.
  
2. From what you have read, who does Fairtrade benefit?

---

---

3. When did Fairtrade start?

---

---

4. According to the text, what does the Fairtrade organisation take into account when determining price?

---

---

5. According to the Fairtrade Foundation's annual report for 2019–2020, sales of Fairtrade products in the UK reached £1.7 billion. What percentage increase was this on the previous year?

---

---





6. What is meant by 'your breakfast has travelled a long way before it reached your plate'? (Line 14)
- A You live a long way from the supermarket.
  - B Your dining room is a long way from the fridge.
  - C The food is produced by farmers in developing countries miles away.
  - D Your supermarket home delivery takes a long time to arrive.
  - E You order food items that are delivered direct, from all around the world.

7. When is World Fair Trade Day?

---

8. Which of these products is not listed in the text as being available under the Fairtrade mark?

- A coffee
- B tea
- C sugar
- D flour
- E honey

9. Which material is described as 'one of the most widely traded commodities in the world'?

---

---

10. How does Fairtrade help cotton farmers?

---

---





11. Use the context of the text to choose the most suitable definition for 'commodity'?  
(Line 31)
- A material
  - B cotton
  - C farmer
  - D production
  - E essential
12. What percentage of cotton farmers live in poverty?
- A 50%
  - B 75%
  - C 25%
  - D 10%
  - E 90%
13. What does the term 'sustainable farming practices' mean?
- A Farming practices that are harmful to the environment.
  - B Farming practices that are not economically viable.
  - C Farming practices that meet the needs of the present without compromising the ability of future generations to meet their own needs.
  - D Farming practices that are not compatible with modern technology.
  - E Farming practices that do not consider the impact on local communities.
14. Which of these is not a step the article recommends that schools take to encourage buying Fairtrade cotton?
- A Make a display about Fairtrade.
  - B Force all parents / carers to buy only Fairtrade uniforms.
  - C Give a presentation on Fairtrade.
  - D Ask local uniform shops to stock Fairtrade cotton uniforms.
  - E Write letters on Fairtrade.







15. What type of writing is this extract?
- A Fiction
  - B Autobiography
  - C Fairy tale
  - D Informative text
  - E Fable
16. Which of these words is a synonym for 'annual'? (Line 19)
- A yearly
  - B weekly
  - C daily
  - D monthly
  - E every other year
17. Use the context of the text to choose the best definition for 'yields'. (Line 34)
- A revenue
  - B crops
  - C produce
  - D money
  - E reputation
18. In the context of the extract, which of the words below is the closest synonym for 'cultivate'?
- A grow
  - B picked
  - C consumed
  - D sold
  - E retail





**19.** What is meant by 'put it somewhere prominent'? (Line 40)

---

---

**20.** Who is the text written for?

---

---



## Section 2: Spelling

In these sentences there are some spelling mistakes. In each question there is either one mistake or no mistake. Find the group of words with the mistake in it. If there is no mistake, choose N.

21. "Wear are you going at this time of night?" asked the police officer.

A	B	C	D	N
---	---	---	---	---

22. Sylvia has been the lead danser at the Lancet Dance School for 3 years.

A	B	C	D	N
---	---	---	---	---

23. The auther, Roald Dahl, wrote more than fifty books in his lifetime.

A	B	C	D	N
---	---	---	---	---

24. She had a mischievous sense of humour and a broad smile.

A	B	C	D	N
---	---	---	---	---

25. He started moving to the rhythm of the music, swaying across the room.

A	B	C	D	N
---	---	---	---	---

26. As winter hit, the trees started to loose their leaves.

A	B	C	D	N
---	---	---	---	---

27. At the farm, I saw horses poking there heads over their stable doors.

A	B	C	D	N
---	---	---	---	---

28. It's pouring down and I've forgotton my umbrella – what a nuisance!

A	B	C	D	N
---	---	---	---	---

29. I couldn't believe my luck – the offer was to good to refuse!

A	B	C	D	N
---	---	---	---	---

30. They booked an expensive Italian restarant to celebrate their anniversary.

A	B	C	D	N
---	---	---	---	---

31. February is the only month that can have 28 days.

A	B	C	D	N
---	---	---	---	---

32. Even though he was exhausted, he perseved and finished the marathon.

A	B	C	D	N
---	---	---	---	---

### Section 3: Punctuation

In these sentences there are some punctuation errors. In each question there is either one mistake or one piece of missing punctuation. Find the group of words with the mistake in it. If there is no mistake, choose N.

33. "Oli has a set routine in the morning" Mrs Davis explained to the dog walker.

A	B	C	D	N
---	---	---	---	---

34. We needed to buy bananas strawberries and yoghurt to make smoothies.

A	B	C	D	N
---	---	---	---	---

35. "Stop" cried the instructor. "You are too close to the edge of the cliff."

A	B	C	D	N
---	---	---	---	---

36. Why do airports pose a risk to our environment?

A	B	C	D	N
---	---	---	---	---

37. We're looking for a dog friendly hotel in the Lake District.

A	B	C	D	N
---	---	---	---	---

38. She is coming to our house after work around 5 o clock.

A	B	C	D	N
---	---	---	---	---



39. They're planning a family holiday in Europe in the summer.

A	B	C	D	N
---	---	---	---	---

40. You are required to bring the following items, socks, hat and gloves.

A	B	C	D	N
---	---	---	---	---

41. I went to the cinema with Lara (my sister) to see the new action movie.

A	B	C	D	N
---	---	---	---	---

42. How many days are there in one year!

A	B	C	D	N
---	---	---	---	---

43. The dog's fur was dirty and matted after jumping in the pond.

A	B	C	D	N
---	---	---	---	---

44. We could go fishing on Saturday; you could borrow a rod from my dad.

A	B	C	D	N
---	---	---	---	---

### Section 4: Grammar

Choose the correct word or short phrase to complete each sentence. Each sentence must make sense and use Standard English.

45. The hikers had \_\_\_\_\_ it was late before they had set off.

- A. no                      B. now                      C. know                      D. known                      E. knowing

46. The dog was chasing \_\_\_\_\_ own tail.

- A. it                      B. it's                      C. its                      D. is                      E. it is





47. Yesterday Miles and his brother \_\_\_\_\_ like cat and dog.  
 A. fight      B. fought      C. fought      D. had fought      E. fought

48. Mount Everest is the \_\_\_\_\_ mountain in the world.  
 A. tall      B. taller      C. tallest      D. most tall      E. mostest tall

49. While the children were walking, \_\_\_\_\_ feet got wet in the puddles.  
 A. they      B. theyre      C. they're      D. their      E. its

50. The Christmas lights in town \_\_\_\_\_ going to be switched on on Saturday.  
 A. we're      B. were      C. where      D. was      E. will

Identify the part of the sentence that contains the **subject**.

51. The firefighter reached the scene in time to extinguish the fire.

A	B	C	D	E
---	---	---	---	---

52. After lunch, I will do some shopping for my elderly neighbours.

A	B	C	D	E
---	---	---	---	---

Identify the part of the sentence that contains a **preposition**.

53. Mr Patel poured the steaming hot chocolate into his flask.

A	B	C	D	E
---	---	---	---	---

54. We rode along the sea shore on our new bicycles.

A	B	C	D	E
---	---	---	---	---





Identify the part of the sentence that contains an **onomatopoeic word**.

55. The lightning flashed and the thunder rumbled in the distance.

A	B	C	D	E
---	---	---	---	---

56. He sprayed the paint evenly over the surface.

A	B	C	D	E
---	---	---	---	---

**END OF TEST**





# SELF REFLECTION

Take some time to reflect on your review test experience. Although they may sometimes feel stressful, exams can also be valuable learning opportunities.

## Your preparation

How confident did you feel going into the exam?



Did you prepare / revise for the test in any way?

---

---

## Your performance

Did you understand and follow the instructions given for the exam?

<input type="checkbox"/>	<input type="checkbox"/>
yes	no

Did you have enough time to answer all the questions in the exam?

<input type="checkbox"/>	<input type="checkbox"/>
yes	no

Which topics were you most confident answering?

---

---

Which topics were you least confident answering?

---

---

What emotions did you feel during the exam?

---

---

## What might you do differently next time?

In preparation for your next exam, write down one thing you will keep doing and one thing you will change for next time.

Keep	Change



# Mock Paper A – VR

## Read the instructions carefully.

1. This is a multiple-choice paper.
2. The paper contains a number of different types of question. Each question types starts with an explanation of what to do.
3. Some questions require more than one answer to be marked. Read the instructions carefully.
4. Circle the correct answer or answers.
5. You have **60 minutes to answer 80 questions**.
6. You may find some of the questions difficult. If you cannot do a question, do not waste time on it, but go on to the next questions. If you are not sure of an answer, choose the one you think is best.
7. Work as quickly and as carefully as you can.
8. Make sure you can see a clock.
9. Allocate enough time to check your answers at the end.



In the questions below, move **one** letter from the word on the left to the word on the right, to create **two** new words. The letters **must not** be rearranged. Both new words must make sense. Choose the letter that moves.

1. greater father

A. g B. e C. a D. t E. r

2. swinging heat

A. w B. i C. n D. g E. n

3. cause bond

A. c B. a C. u D. s E. e

4. wheat shin

A. w B. h C. e D. a E. t

In the sentence below, one word in capitals has had **three consecutive letters taken out**. These three letters on their own make **one correctly spelt word**, without changing the order. Choose the three-letter word from the options below.

5. She was WING red wellington boots and a matching red hat.

A. ink B. eat C. has D. ear E. ash

6. The suitcase has a separate COMTMENT for valuable items.

A. par B. pat C. lip D. cap E. map

7. Some animals MIGE annually in search of food.

A. rip B. pat C. kit D. rat E. lap

Two words have had one letter removed and their remaining letters mixed up. The same letter has been removed from both words. Unscramble the letters and work out which letter is missing.

8. The team wedo the boat down the irev.

A. m B. s C. r D. n E. c





9. He oepshd his aheter shoes until they shone.

- A. g                      B. r                      C. u                      D. n                      E. l

10. The obcerb repaired the ehe on the broken boot.

- A. m                      B. l                      C. h                      D. f                      E. r

In the questions below, find the number that continues the series in the most sensible way.

11. 12, 32, 44, 76, 120, ?

- A. 196                      B. 180                      C. 201                      D. 178                      E. 191

12. -18, -36, -72, -144, -288, ?

- A. -336                      B. -497                      C. -576                      D. -675                      E. -688

13. 16, 41, 66, 91, 116, ?

- A. 140                      B. 136                      C. 143                      D. 141                      E. 139

14. 3, 15, 51, 159, 483, ?

- A. 1,449                      B. 1,398                      C. 1,502                      D. 1,450                      E. 1,455

15. Sasha is double the age that Jasper was three years ago. Jasper is 8. Nala is four years younger than Sasha. Krish is four years older than Nala. Who is six years old?

- A. Sasha                      B. Jasper                      C. Nala                      D. Krish                      E. Nobody

16. Isla, Hamza, Tara and Kamran are all friends from school. They went on a trip to the beach. They all found some beautiful shells to take home. Isla found two more than Hamza. Kamran found four fewer than Isla. Tara found the same amount as Isla. Hamza found 14. Who found fewer shells than Hamza?

- A. Kamran                      B. Hamza                      C. Isla                      D. Tara                      E. Nobody

17. My watch is 12 minutes fast. My train, which should have arrived at 5:26 p.m., is eight minutes late. What time does my watch show when the train arrives?

- A. 5:26pm                      B. 5:46pm                      C. 5:29pm                      D. 5:48pm                      E. 5:40pm





18. Sarah keeps three pet snakes. One snake eats two mice every seven days. How many mice will Sarah need to feed all her snakes for four weeks?
- A. 21                      B. 23                      C. 14                      D. 12                      E. 24

Find the **two** words, one from each group, that are most similar in meaning. Select the **two** words from the options below.

19. (genuine, inclination, isolation)    (repel, fake, sincere)

- |                |            |
|----------------|------------|
| A. genuine     | X. repel   |
| B. inclination | Y. fake    |
| C. isolation   | Z. sincere |

20. (monotonous, modest, meticulous)    (attentive, careless, aspiration)

- |               |               |
|---------------|---------------|
| A. monotonous | X. attentive  |
| B. modest     | Y. careless   |
| C. meticulous | Z. aspiration |

21. (nostalgic, disdain, anxious)    (sentimental, immediate, inhale)

- |              |                |
|--------------|----------------|
| A. nostalgic | X. sentimental |
| B. disdain   | Y. immediate   |
| C. anxious   | Z. inhale      |

22. (delirious, predilection, ponderous)    (preference, dislike, compel)

- |                 |               |
|-----------------|---------------|
| A. delirious    | X. preference |
| B. predilection | Y. dislike    |
| C. ponderous    | Z. compel     |





Find the **two** words, one from each group, that are most opposite in meaning.

**23.** (narrative, compile, chaos) (dismantle, assemble, compose)

- |              |              |
|--------------|--------------|
| A. narrative | X. dismantle |
| B. compile   | Y. assemble  |
| C. chaos     | Z. compose   |

**24.** (virtuous, hinder, polite) (courteous, curt, insolent)

- |             |              |
|-------------|--------------|
| A. virtuous | X. courteous |
| B. hinder   | Y. curt      |
| C. polite   | Z. insolent  |

**25.** (release, tirade, emphasis) (attack, calm, liberate)

- |             |             |
|-------------|-------------|
| A. release  | X. attack   |
| B. tirade   | Y. calm     |
| C. emphasis | Z. liberate |

Find **two** words, **one** from each group, that together make one correctly spelt word, without changing the order of the letters. The word from the first group always comes first.

**26.** (goose, base, unit) (stand, ball, bat)

- |          |          |
|----------|----------|
| A. goose | X. stand |
| B. base  | Y. ball  |
| C. unit  | Z. bat   |





27. (pepper, spice, mill) (salt, table, mint)
- A. pepper X. salt
- B. spice Y. table
- C. mill Z. mint
28. (straw, black, butter) (bread, scotch, post)
- A. straw X. bread
- B. black Y. scotch
- C. butter Z. post
29. (hand, here, head) (line, circle, neck)
- A. hand X. line
- B. here Y. circle
- C. head Z. neck

Find the **two** words, one from each group, that will complete the sentence in the best way.

30. smart is to (clothes, trams, interview) as time is to (emit, watch, travel)
- A. clothes X. emit
- B. trams Y. watch
- C. interview Z. travel
31. peace is to (pace, waves, tranquil) as retract is to (confirm, withdraw, prolong)
- A. pace X. confirm
- B. waves Y. withdraw
- C. tranquil Z. prolong





32. dolphin is to (pod, whale, fin) as giraffe is to (neck, shoots, tower)

- |          |           |
|----------|-----------|
| A. pod   | X. neck   |
| B. whale | Y. shoots |
| C. fin   | Z. tower  |

Work out the correct word to complete the sentence. The word on the left in bold, is a clue. It rhymes with a synonym of the missing word, but not the word itself.

33. **sure** Made from solid iron, the gate was sure to \_\_\_\_\_ any bad weather.

- |            |          |           |             |          |
|------------|----------|-----------|-------------|----------|
| A. survive | B. break | C. endure | D. withdraw | E. force |
|------------|----------|-----------|-------------|----------|

34. **fluff** The fabric varies in texture from \_\_\_\_\_ to fine.

- |          |         |           |          |           |
|----------|---------|-----------|----------|-----------|
| A. silky | B. soft | C. fluffy | D. rough | E. coarse |
|----------|---------|-----------|----------|-----------|

35. **bloat** The mission is to transport medical supplies to \_\_\_\_\_ areas of the globe.

- |           |          |            |             |            |
|-----------|----------|------------|-------------|------------|
| A. remote | B. faint | C. central | D. isolated | E. popular |
|-----------|----------|------------|-------------|------------|

There are three pairs of words. Complete the third pair so they have the same connection as the first two pairs.

36. (water, raw) (rides, sir) (taste, \_\_\_\_\_)

- |         |        |        |          |         |
|---------|--------|--------|----------|---------|
| A. eats | B. ate | C. eat | D. eaten | E. east |
|---------|--------|--------|----------|---------|

37. (player, real) (flares, seal) (draped, \_\_\_\_\_)

- |         |          |         |         |         |
|---------|----------|---------|---------|---------|
| A. dear | B. dread | C. pear | D. deer | E. read |
|---------|----------|---------|---------|---------|

38. (spoon, son) (beast, bat) (meant, \_\_\_\_\_)

- |        |        |         |        |        |
|--------|--------|---------|--------|--------|
| A. met | B. man | C. mate | D. men | E. mat |
|--------|--------|---------|--------|--------|

Find the pair of letters that continues the series in the most sensible way. Choose one pair from the answers below.

**A B C D E F G H I J K L M N O P Q R S T U V W X Y Z**

39. PA, SC, XG, EM, NU, ?

- |       |       |       |       |       |
|-------|-------|-------|-------|-------|
| A. ZC | B. AE | C. ZE | D. YE | E. YD |
|-------|-------|-------|-------|-------|





40. IB, KE, IC, KF, ID, ?

- A. KG                      B. FC                      C. KB                      D. ID                      E. IB

41. KR, NU, SZ, ZG, IP, ?

- A. UC                      B. SA                      C. TB                      D. DB                      E. TA

42. HB, JD, GA, IC, FZ, ?

- A. HC                      B. IJ                      C. GY                      D. HB                      E. GA

A **four-letter word** is hidden at the **end** of one word and the **beginning** of the next word in the sentence. Find the pair of words that contains the hidden word.

43. This apple added a sweetness to the pie.

- A. this apple      B. apple added      C. added a      D. sweetness to      E. the pie

44. She told her superhero fanatic, older brother about the movie.

- A. she told      B. fanatic older      C. older brother      D. about the      E. the movie

45. Eva thought the hotel seemed a little rundown.

- A. Eva thought      B. thought the      C. hotel seemed      D. seemed a      E. a little

The words below are a jumbled sentence with one extra word. Identify the superfluous word from the sentence.

46. spoonfuls two I tea like milk in my sugar of

- A. in                      B. tea                      C. milk                      D. sugar                      E. two

47. looked I sights in area the researched best the

- A. in                      B. sights                      C. area                      D. best                      E. looked

48. was mist dawn weather there an at eerie

- A. was                      B. mist                      C. eerie                      D. weather                      E. dawn







The three words in the second group should go together in the same way as the three in the first group. Choose the missing word.

49. threat (either) winter / phrase ( \_\_\_\_\_ ) custom

- A. author      B. assort      C. aspect      D. actors      E. ashore

50. mobile (belong) single / fabric ( \_\_\_\_\_ ) gather

- A. breach      B. breath      C. bright      D. crater      E. beach

51. review (inside) fiends / filled ( \_\_\_\_\_ ) street

- A. lister      B. litter      C. filler      D. letter      E. relief

**Three** of the **five** words listed below are related in some way. Find the two words that do not go with these three.

52. (orange, fruit, red, yellow, banana)

- A. orange      B. fruit      C. red      D. yellow      E. banana

53. (cheese, cow, farm, cream, milk)

- A. cheese      B. cow      C. farm      D. cream      E. milk

54. (thriller, film, comedy, book, romance)

- A. thriller      B. film      C. comedy      D. book      E. romance

There is an alphabet line to help you. Find the letters that will complete the sentence in the best way.

**A B C D E F G H I J K L M N O P Q R S T U V W X Y Z**

55. ST is to AN as UT is to ?

- A. BN      B. CN      C. CO      D. DN      E. DM

56. ZF is to NK as WX is to ?

- A. LC      B. JD      C. KB      D. KC      E. LB

57. XW is to EJ as ON is to ?

- A. UA      B. VA      C. UZ      D. ZA      E. WA





58. SS is to UA as FF is to

- A. HN                      B. GO                      C. IN                      D. GN                      E. HO

Find the number that will complete the sum correctly.

59.  $13 \times 7 = 8 \times (\underline{\quad}) + 11$

- A. 19                      B. 12                      C. 8                      D. 14                      E. 10

60.  $156 \div 12 = 98 - 39 - (\underline{\quad})$

- A. 46                      B. 48                      C. 47                      D. 42                      E. 44

61.  $12 \times 9 + 2 = 11 \times (\underline{\quad})$

- A. 15                      B. 13                      C. 12                      D. 10                      E. 11

There are two pairs of words. You must select a word from the options below that will go equally well with both pairs.

62. (cod, haddock)                      (drum, trombone)

- A. cymbal                      B. bass                      C. tuna                      D. sea                      E. tuba

63. (promise, commitment)                      (catch, gain)

- A. truth                      B. ball                      C. law                      D. contract                      E. throw

64. (rainforest, grassland)                      (abandon, leave)

- A. place                      B. land                      C. mountains                      D. ocean                      E. desert

65. (activity, plan)                      (protrude, jut)

- A. draw                      B. kit                      C. project                      D. rock                      E. aim

The three numbers in each group are related to each other in the same way as the other two groups. Find the number that completes the last group.

66. (3, [15], 27)                      (1, [11], 5)                      (2, [ ], 8)

- A. 6                      B. 4                      C. 22                      D. 10                      E. 12

67. (3, [14], 4)                      (6, [24], 6)                      (8, [ ], 5)

- A. 26                      B. 36                      C. 24                      D. 12                      E. 40





68. (3, [20] , 7) (5, [4] , 1) (3, [ \_ ] , 2)
- A. 1                      B. 10                      C. 12                      D. 5                      E. 6

In these question, letters stand for numbers. Use the code to work out the answer to the calculation. Choose the correct letter as your answer.

69. **A = 5    B = 1    C = 8    D = 3    E = 6**
- (C + D + B) ÷ 2 =
- A. A                      B. B                      C. C                      D. D                      E. E

70. **A = 8    B = 3    C = 4    D = 2    E = 6**
- Divide the product of CDE by A then subtract C.
- A. A                      B. B                      C. C                      D. D                      E. E

71. **A = 32    B = 4    C = 8    D = 24    E = 12**
- (C × E) ÷ B =
- A. A                      B. B                      C. C                      D. D                      E. E

Find **one** letter that will complete the word in front of the brackets and begin the word after the brackets. The **same letter** must fit into both sets of brackets.

72. COM ( \_\_\_ ) ONE                      LIM ( \_\_\_ ) AND
- A. E                      B. H                      C. T                      D. S                      E. B
73. TO ( \_\_\_ ) ARN                      JO ( \_\_\_ ) AWN
- A. Y                      B. L                      C. T                      D. B                      E. F
74. SO ( \_\_\_ ) ISH                      CLA ( \_\_\_ ) ANT
- A. D                      B. R                      C. F                      D. W                      E. P

**A B C D E F G H I J K L M N O P Q R S T U V W X Y Z**

75. If XQINKR means WOEFUL, what does GWPTUX mean?
- A. FLURRY                      B. FULLER                      C. FUNNEL                      D. FUMBLE                      E. FUTILE





**76.** If the code for OCELOT is PEITEZ, what does DQSTUX mean?

- A. COOLER      B. CLOSER      C. LOCKER      D. CLOSET      E. LOCKER

**77.** If OTXYJU means QUACKS, what does OTXGDT mean?

- A. QUAKES      B. QUAKED      C. QUAKER      D. QUAVER      E. QUARKS

There are four words below and only three codes provided. Three of the four words are given in code. The codes are not written in the same order as the words.

**78.** What is the code for the word MOIST?

- |          |          |          |          |
|----------|----------|----------|----------|
| MIDST    | HOIST    | TIMES    | MISTY    |
| 87035    | 46735    | 87351    |          |
| A. 86735 | B. 46035 | C. 87346 | D. 68735 |
|          |          |          | E. 87635 |

**79.** What is the code for the word HORDE?

- |          |          |          |          |
|----------|----------|----------|----------|
| HOARD    | HYDRO    | OTHER    | CHORD    |
| 35471    | 43018    | 42813    |          |
| A. 34187 | B. 35187 | C. 42813 | D. 43187 |
|          |          |          | E. 43087 |

**80.** What is the code for the word CLOSE?

- |          |          |          |          |
|----------|----------|----------|----------|
| LOOSE    | SCOPE    | CHOSE    | SCORE    |
| 41076    | 20046    | 15046    |          |
| A. 30741 | B. 40636 | C. 12046 | D. 47201 |
|          |          |          | E. 40547 |

**END OF TEST**





# SELF REFLECTION

Take some time to reflect on your review test experience. Although they may sometimes feel stressful, exams can also be valuable learning opportunities.

## Your preparation

How confident did you feel going into the exam?



Did you prepare / revise for the test in any way?

---

---

## Your performance

Did you understand and follow the instructions given for the exam?

<input type="checkbox"/>	<input type="checkbox"/>
yes	no

Did you have enough time to answer all the questions in the exam?

<input type="checkbox"/>	<input type="checkbox"/>
yes	no

Which topics were you most confident answering?

---

---

Which topics were you least confident answering?

---

---

What emotions did you feel during the exam?

---

---

## What might you do differently next time?

In preparation for your next exam, write down one thing you will keep doing and one thing you will change for next time.

Keep	Change

# Mock Paper A – NVR

**Read the instructions carefully.**

1. This is a multiple-choice paper.
2. Circle the correct answer.
3. There are four sections in this paper. These sections are timed separately. You will be told when to start, when to stop a section and when to move on to the next section. You will have **10 minutes to complete each section.**
4. The test lasts for **40 minutes in total.**
5. There are **80 questions in total.**
6. You may find some of the questions difficult. If you cannot do a question, do not waste time on it, but go on to the next questions. If you are not sure of an answer, choose the one you think is best.
7. Work as quickly and as carefully as you can.
8. Make sure you can see a clock.
9. Allocate enough time to check your answers at the end.



**Section 1 – You have 10 minutes to complete this section of the test.**

In the questions below, choose the figure that completes the sentence in the best way.

1.

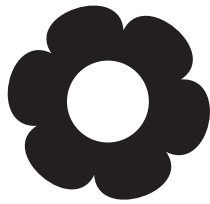

is to

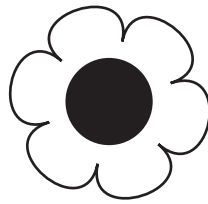

as

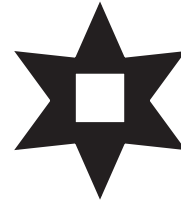

is to...

A.

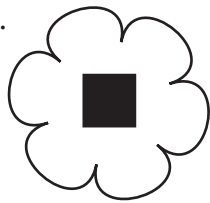

B.

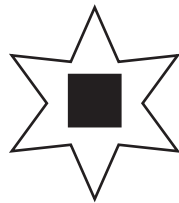

C.

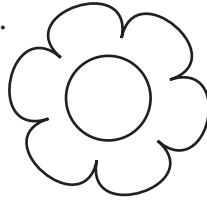

D.

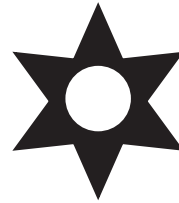

E.

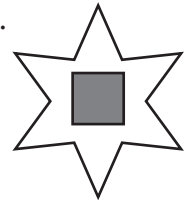

2.

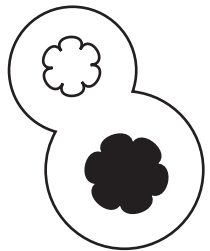

is to

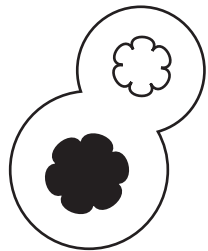

as

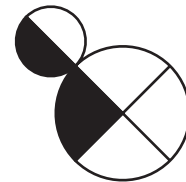

is to...

A.

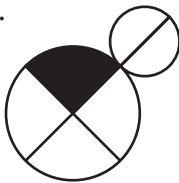

B.

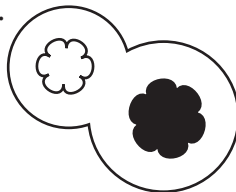

C.



D.

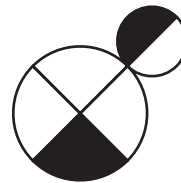

E.

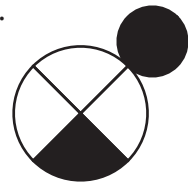

3.

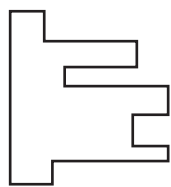

is to

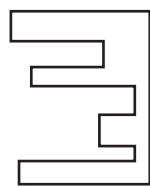

as

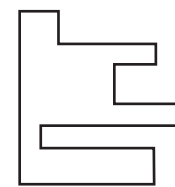

is to...

A.

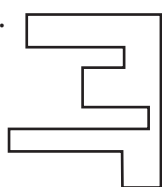

B.

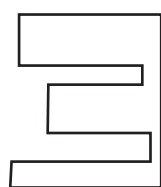

C.

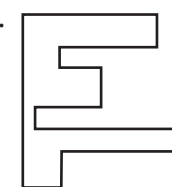

D.

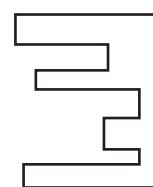

E.

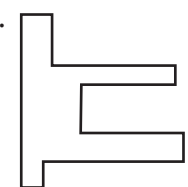



4.

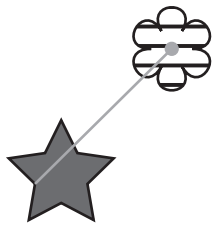

is to

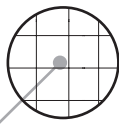

as

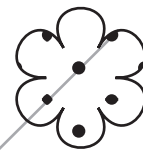

is to...

A.

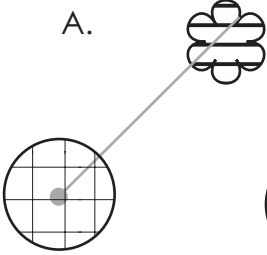

B.

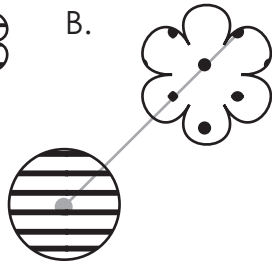

C.

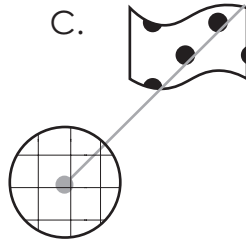

D.

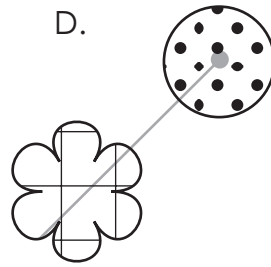

E.

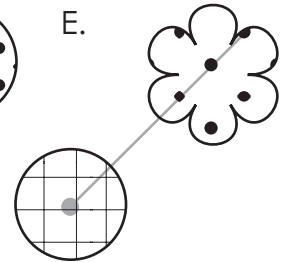

5.

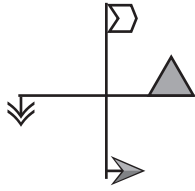

is to

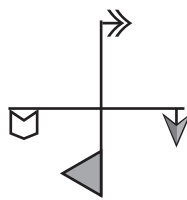

as

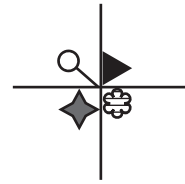

is to...

A.

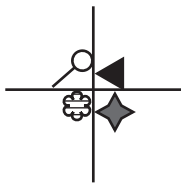

B.



C.



D.

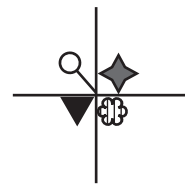

E.

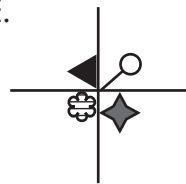

6.

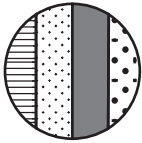

is to

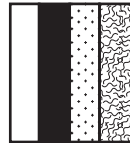

as

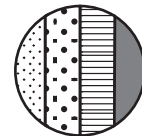

is to...

A.

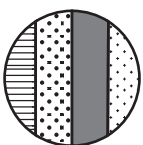

B.

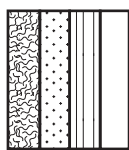

C.

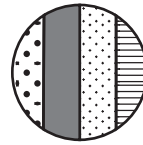

D.

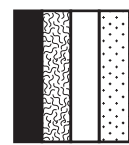

E.



7.

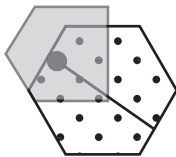

is to

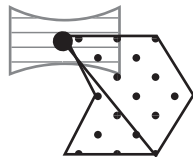

as

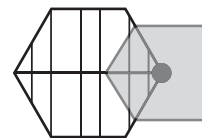

is to...

A.

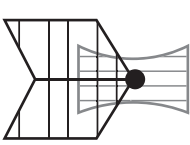

B.

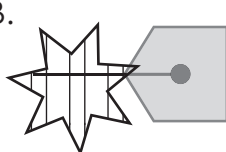

C.

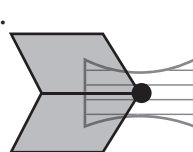

D.

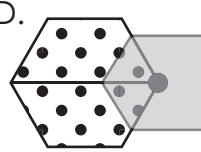

E.

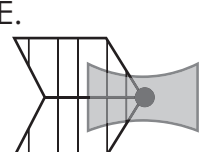





In the questions below, choose the figure that completes the series.

8.

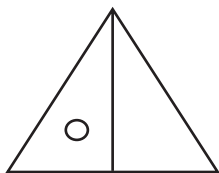

\_\_\_\_\_

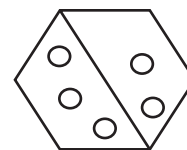
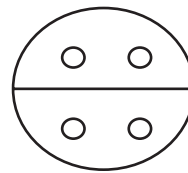
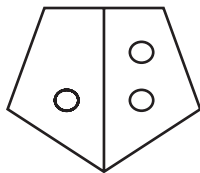

A.

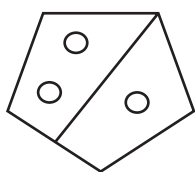

B.

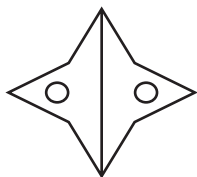

C.

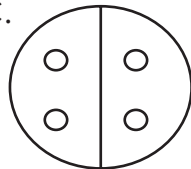

D.

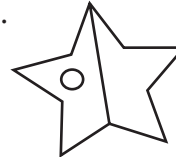

E.

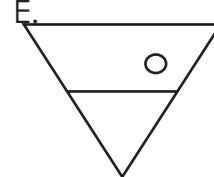

9.

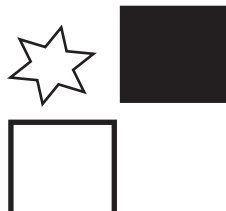
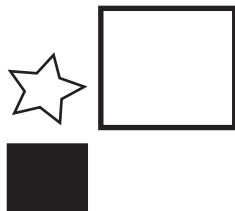

\_\_\_\_\_

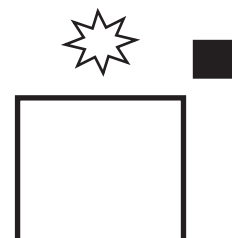

A.

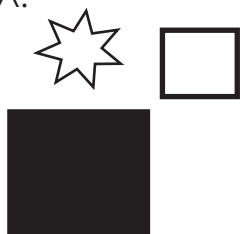

B.

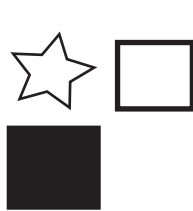

C.

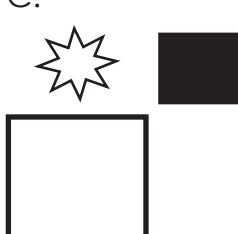

D.

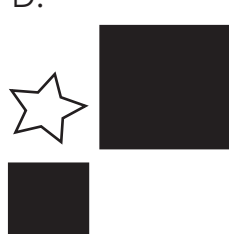

E.

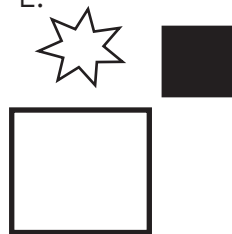

10.

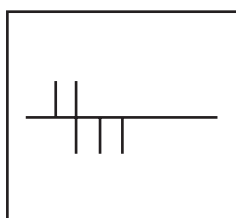
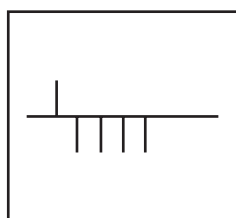

\_\_\_\_\_

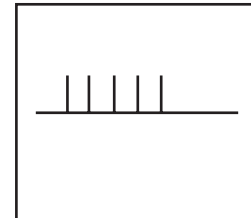
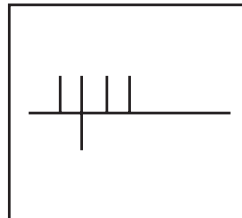

A.

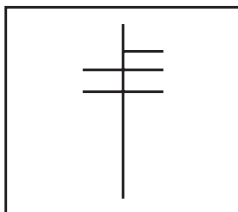

B.

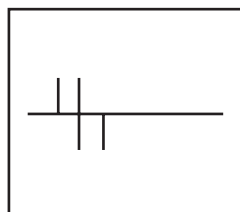

C.

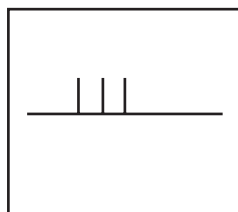

D.

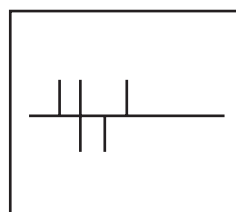

E.

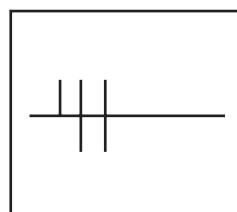



11.

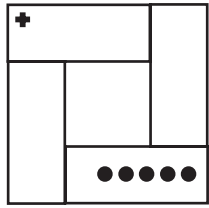

\_\_\_\_\_

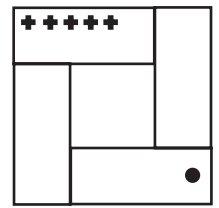
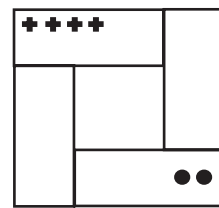
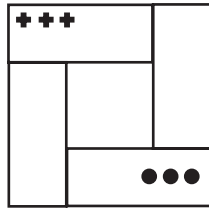

A.

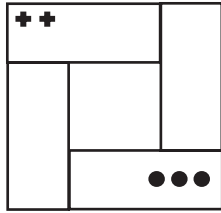

B.

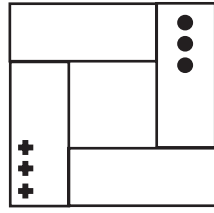

C.

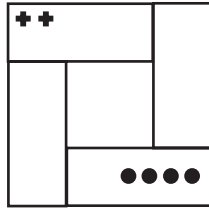

D.

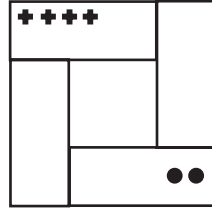

E.

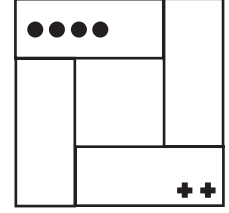

12.

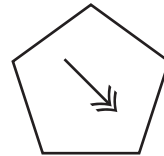
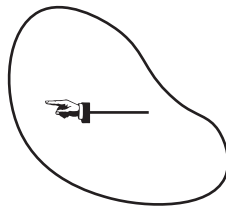
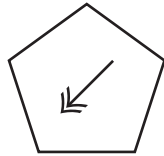
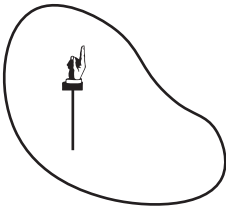

\_\_\_\_\_

A.

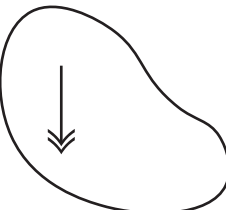

B.

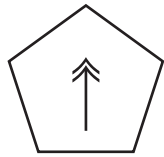

C.

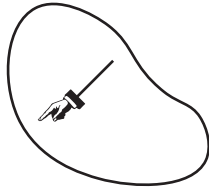

D.

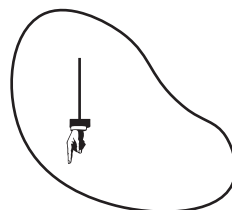

E.

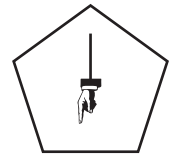

13.

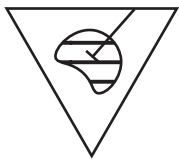

\_\_\_\_\_

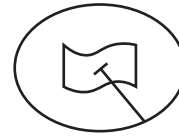

A.



B.



C.

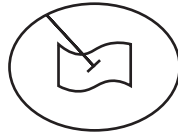

D.



E.

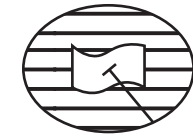



14.

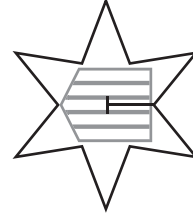
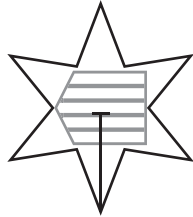
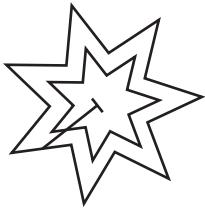

A.

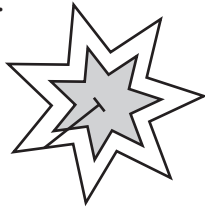

B.

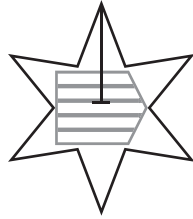

C.

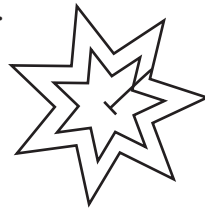

D.

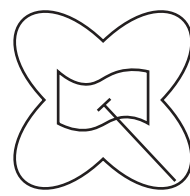

E.

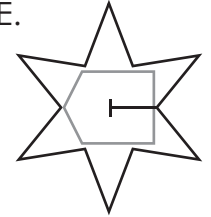

In the questions below, choose the figure that should fill the empty square.

15.

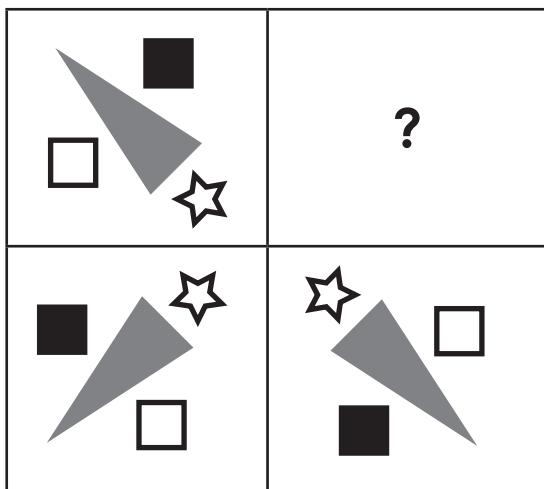

A.

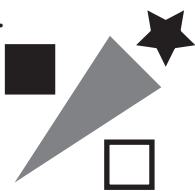

B.

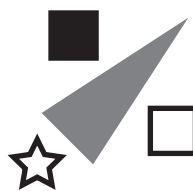

C.

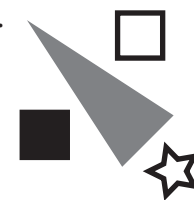

D.

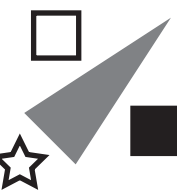

E.

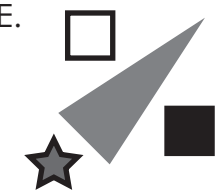



16.

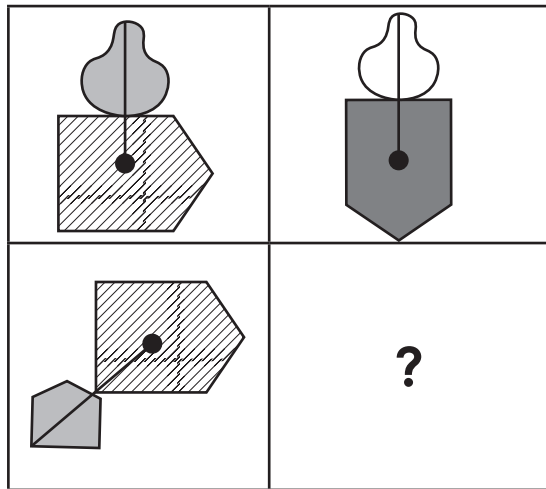

A.

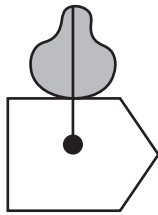

B.

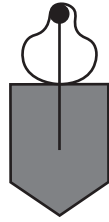

C.

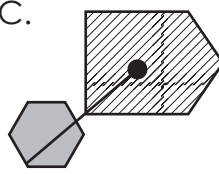

D.

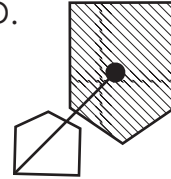

E.

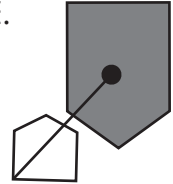

17.

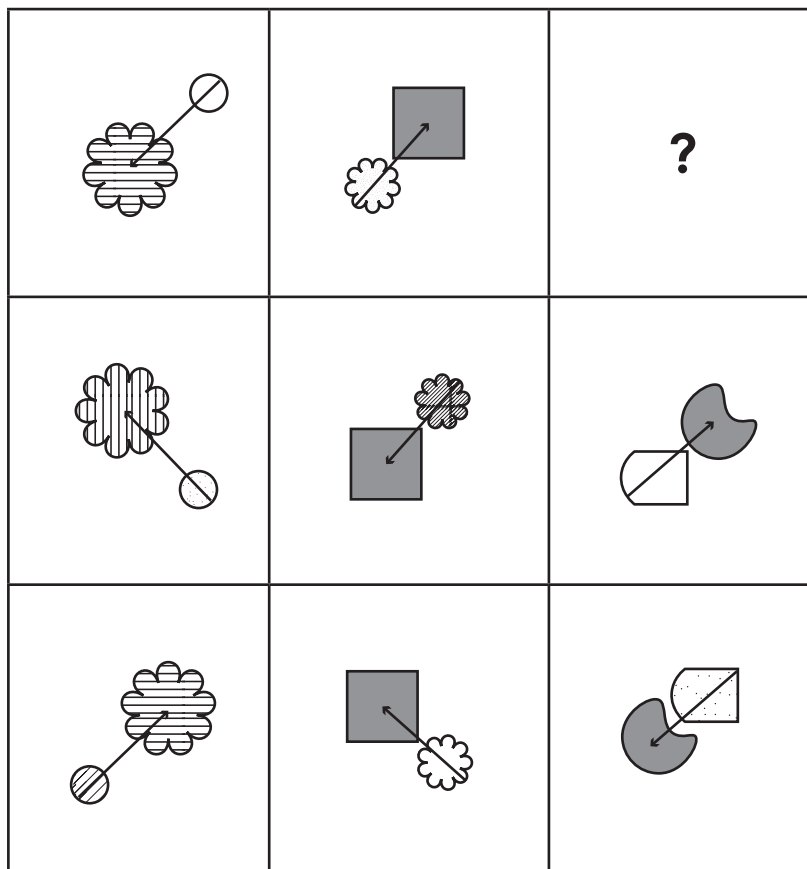

A.

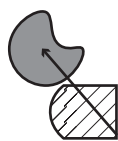

B.

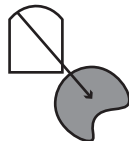

C.



D.

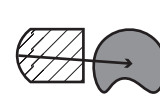

E.

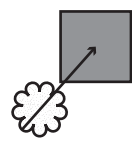



18.

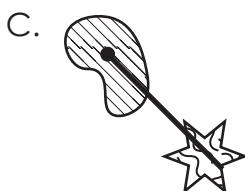
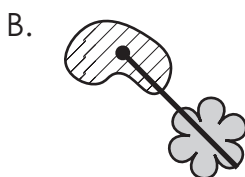
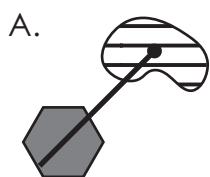
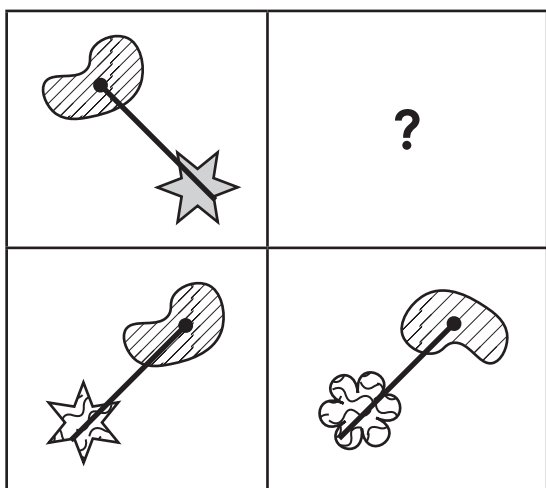

In the questions below, choose the figure that should fill the empty space.

19.

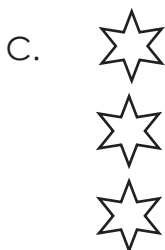
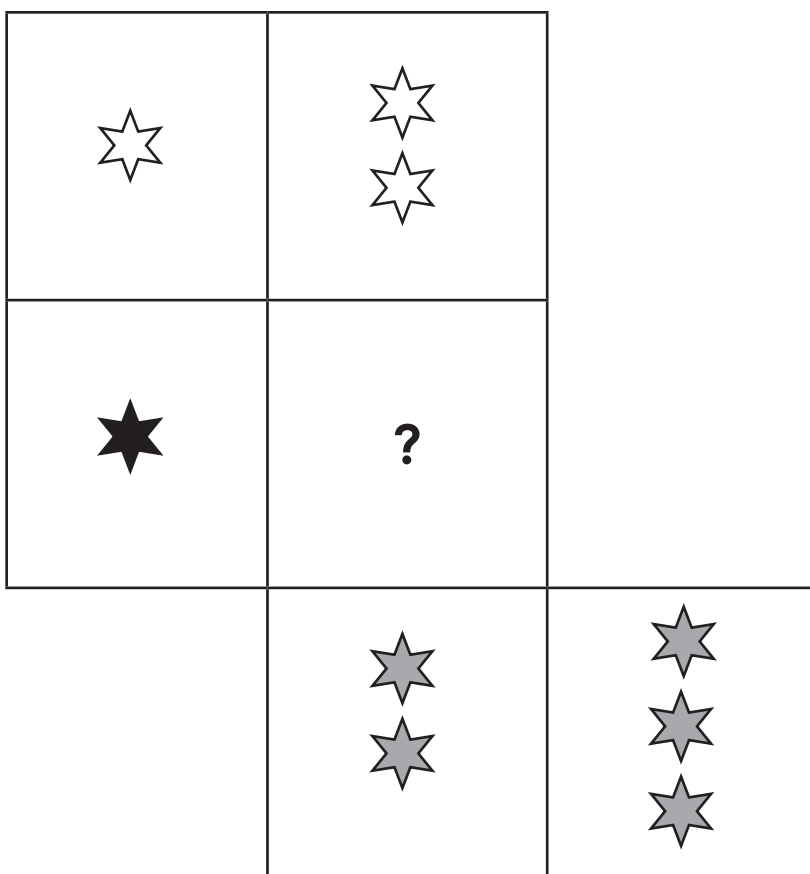



20.

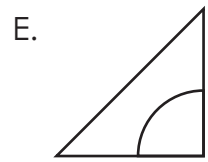
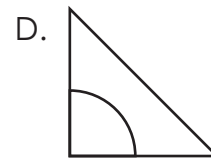
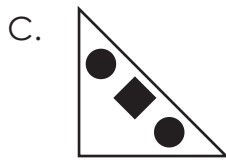
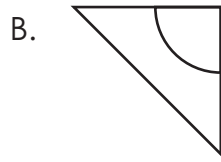
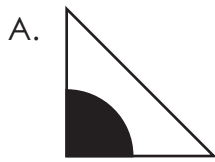
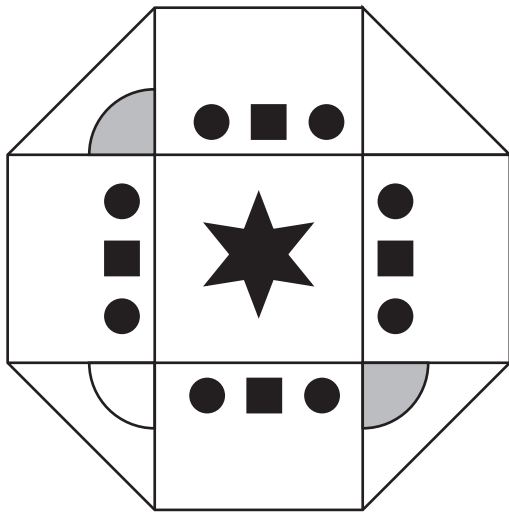

END OF SECTION 1





**Section 2 – You have 10 minutes to complete this section**

In the questions below, choose the missing code.

21.



**HT**

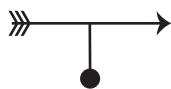

**PY**

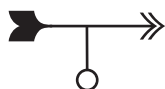

**LY**

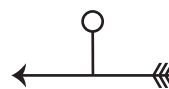

**PT**



**?**

A. HT

B. HY

C. LY

D. YH

E. PH

22.

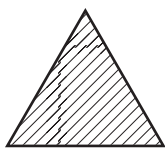

**NJ**

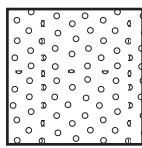

**AR**



**KX**

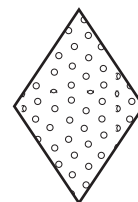

**AX**

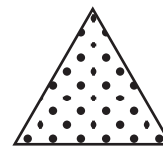

**?**

A. KJ

B. NX

C. AR

D. KR

E. AJ

23.

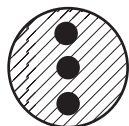

**TYZ**

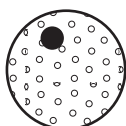

**BYA**



**BWS**



**UFV**



**?**

A. BWZ

B. TWS

C. UWZ

D. BFV

E. BFS

24.



**JRA**



**JCF**

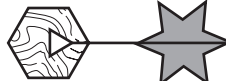

**EQA**



**HRD**



**?**

A. JCA

B. HQF

C. HRF

D. ERF

E. JQD





25.

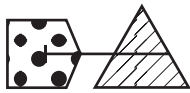

IAS



NES



NAM



IJS



?

A. IEM

B. NAS

C. IES

D. NJM

E. NEM

26.

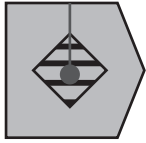

FDYT

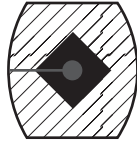

OALG

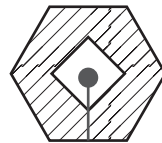

WARU



OXLT

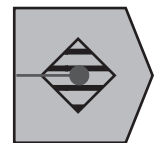

?

A. FALG

B. ODYT

C. FDYG

D. WDYG

E. OAYT

27.

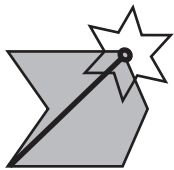

HPEL

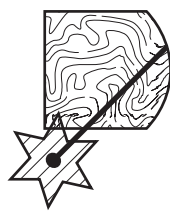

SQTI

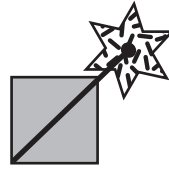

ZPWL

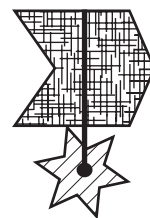

HFTB

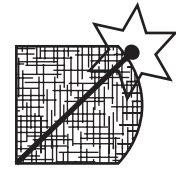

?

A. SFEL

B. HFTL

C. ZFTB

D. SFWL

E. HFTB

In the questions below, choose the figure that is the odd one out.

28.

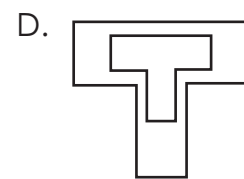
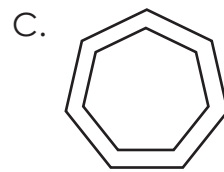
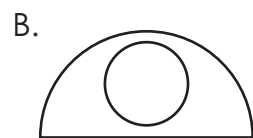

29.

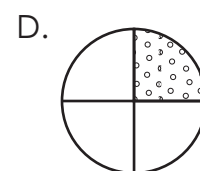
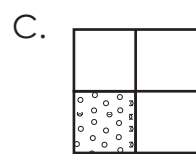
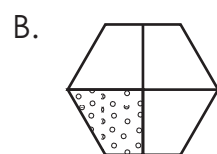
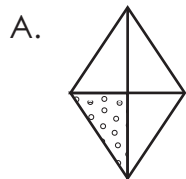



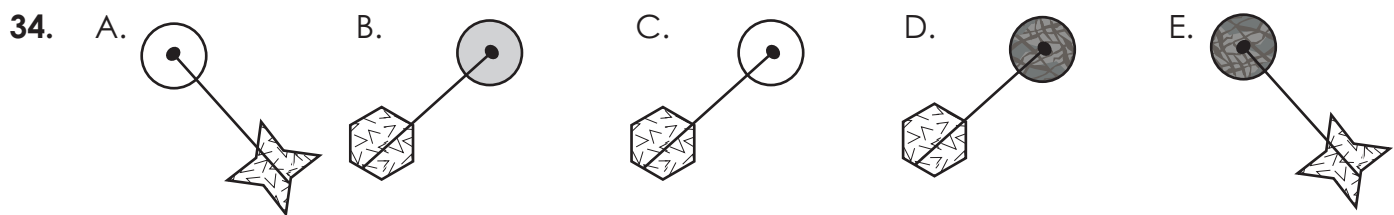
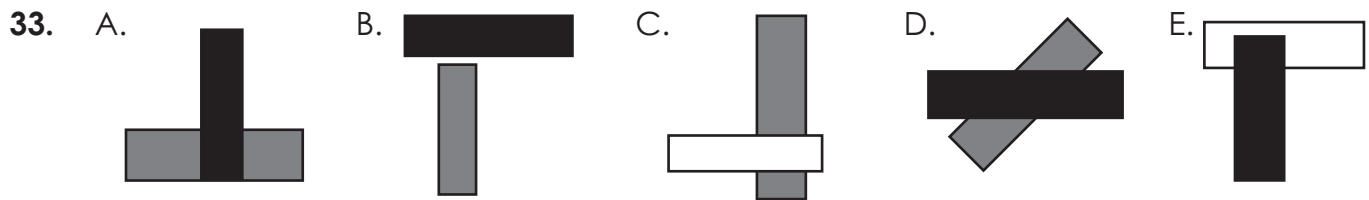
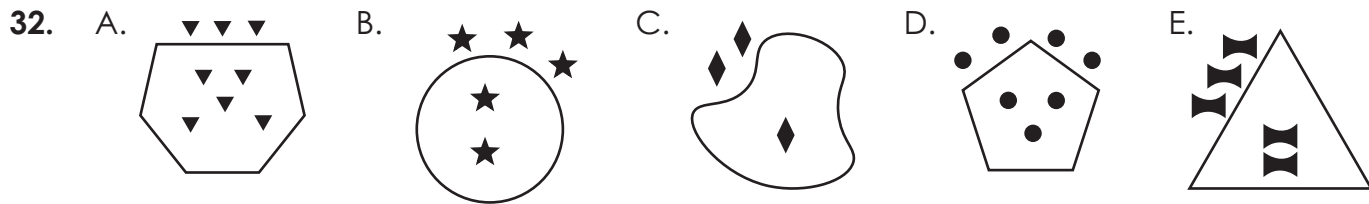
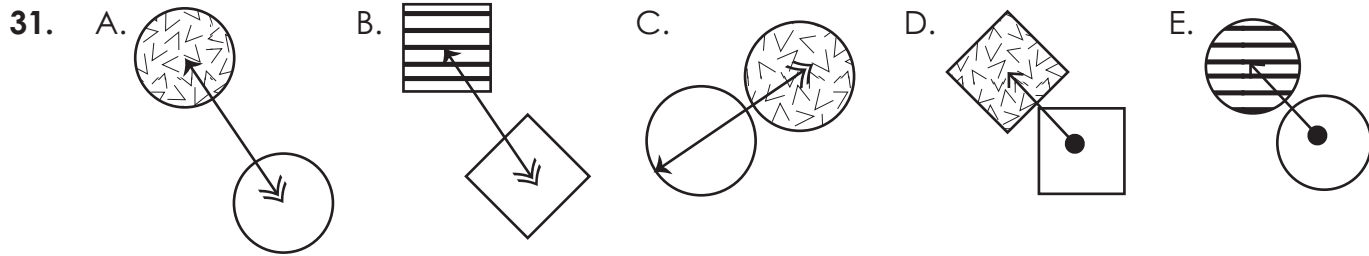
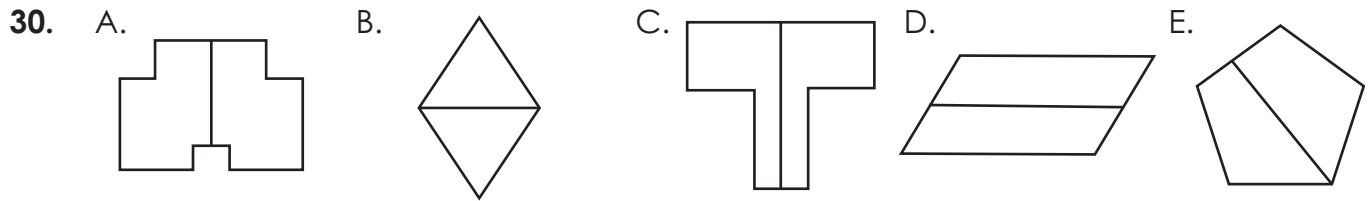

In the questions below, choose the answer option that is most similar to the figures in the question.

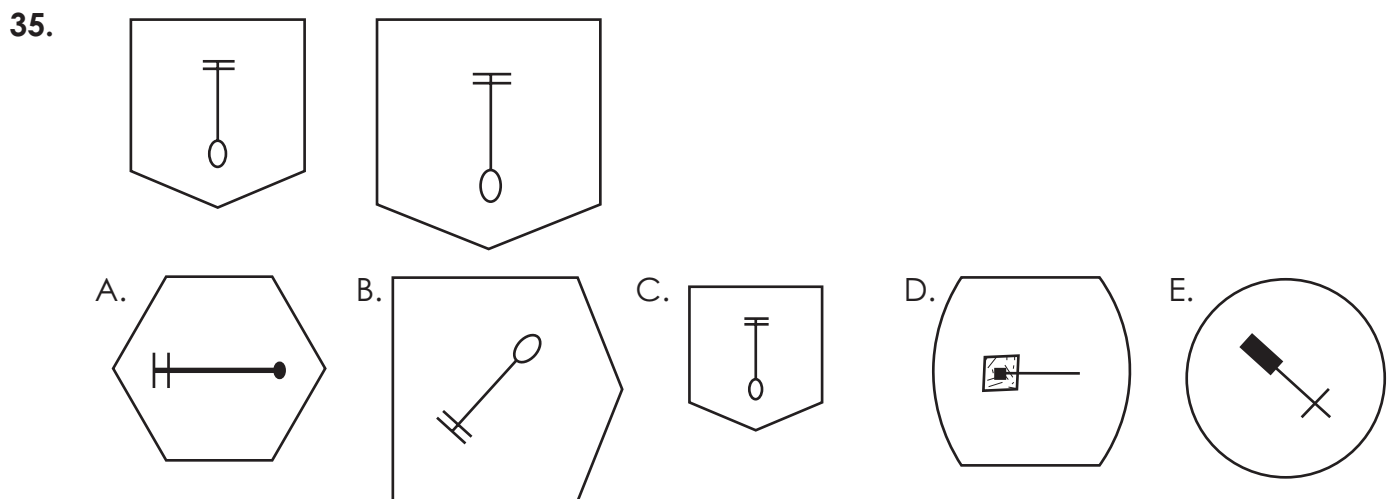



36.

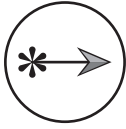
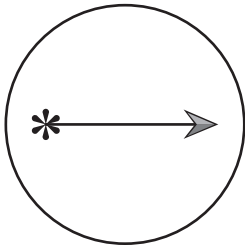

A.

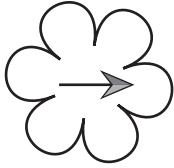

B.

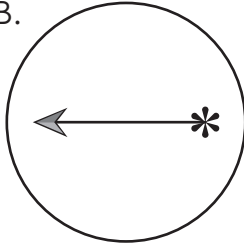

C.

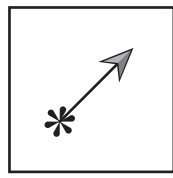

D.

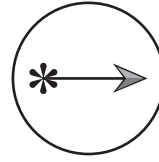

E.

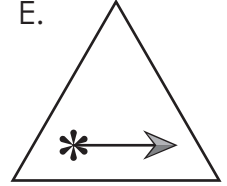

37.

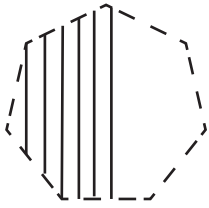

A.

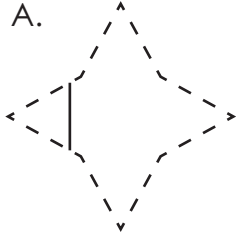

B.

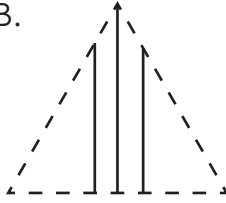

C.

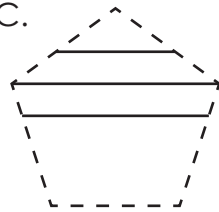

D.

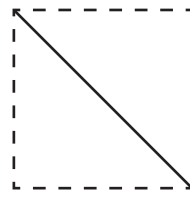

E.

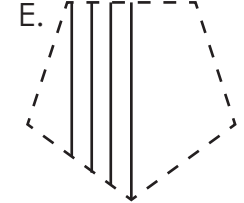

38.

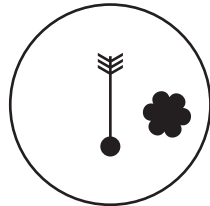
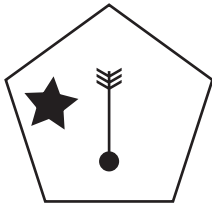

A.

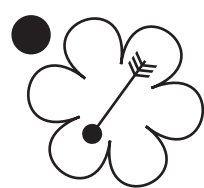

B.

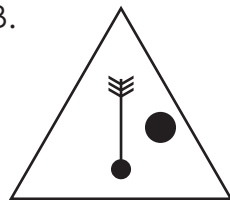

C.

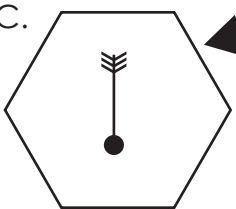

D.

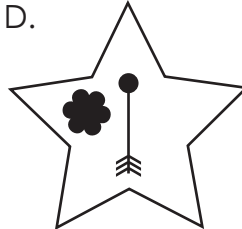

E.

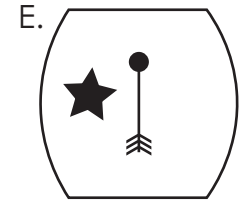



39.

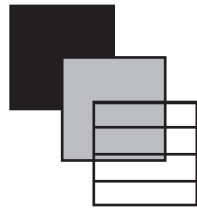

A.



B.



C.



D.



E.



40.

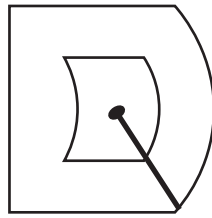
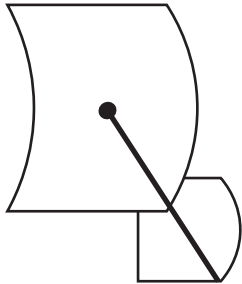

A.



B.

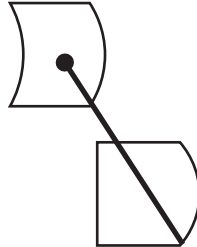

C.

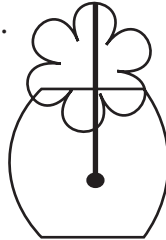

D.

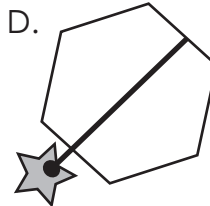

E.



END FOF SECTION 2

Section 3 – You have 10 minutes to complete this section.

In the questions below, look at the shape on the left. In which drawing on the right is it hidden? (Note: it is the same size and is facing the same direction.)

41.

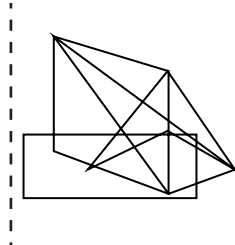

A

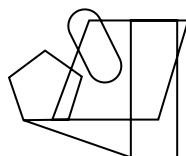

B

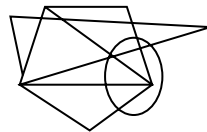

C

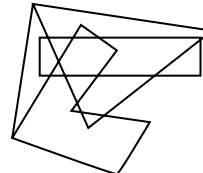

D

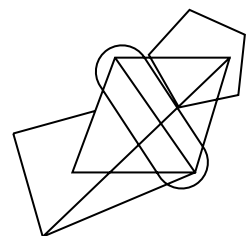

E



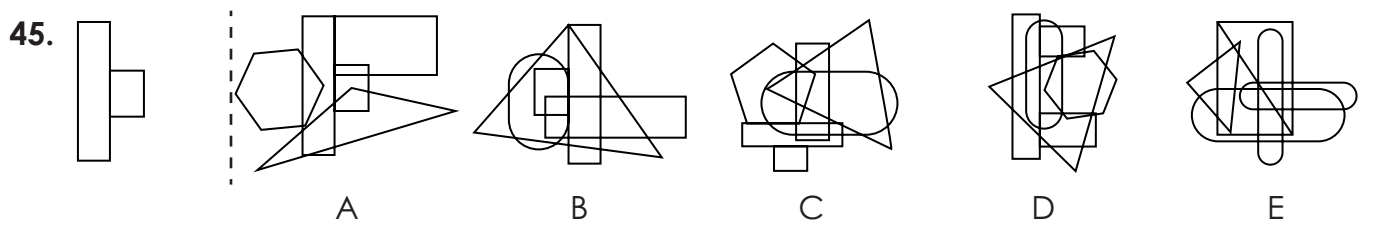
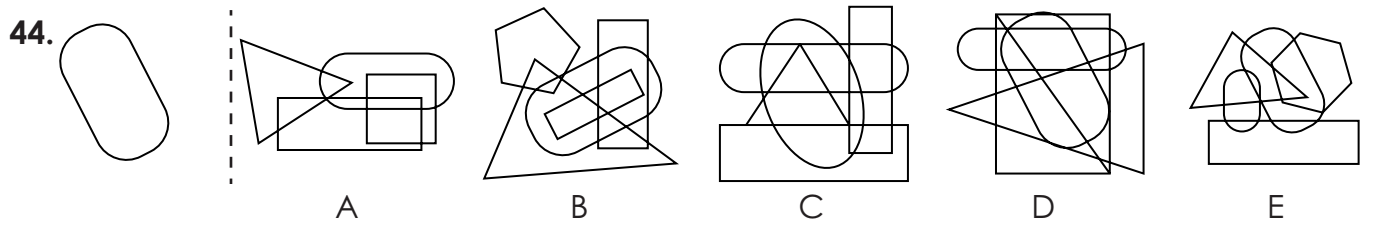
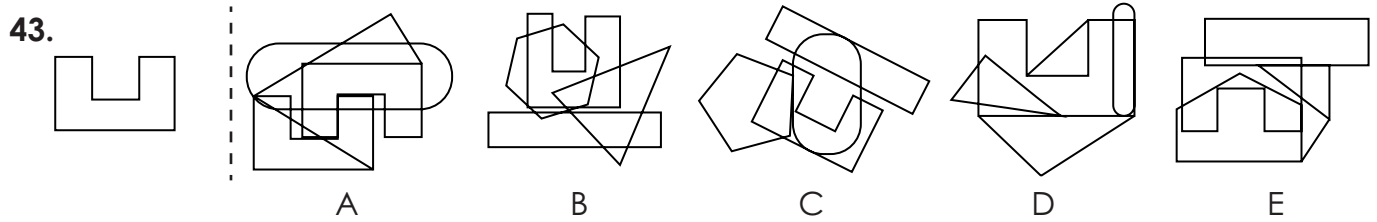
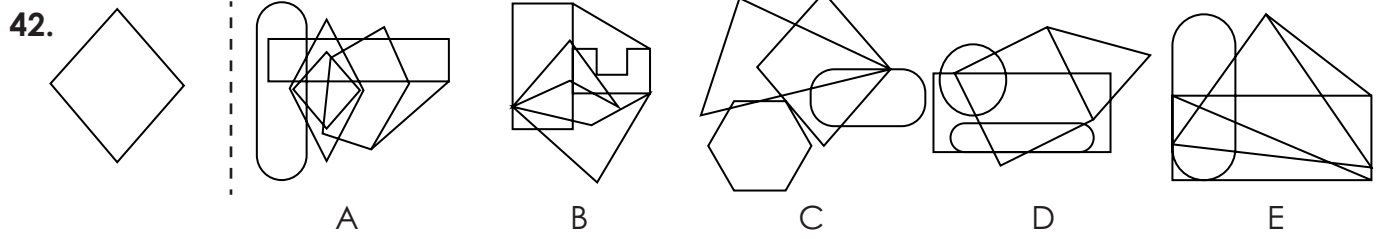

In the questions below, choose the answer option that combines the two figures. The figures may change position, but will not rotate.

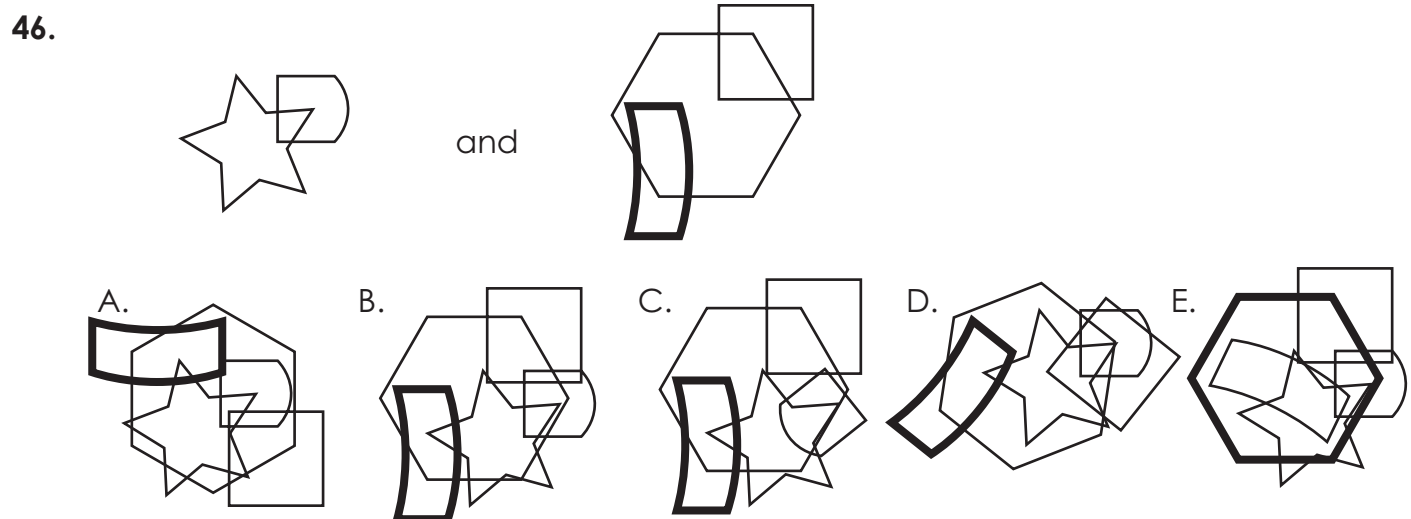



47.

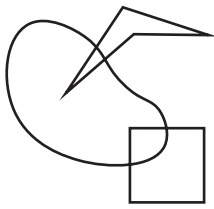

and



A.

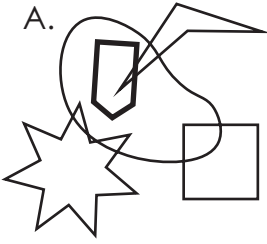

B.

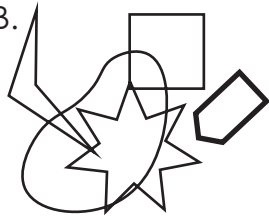

C.

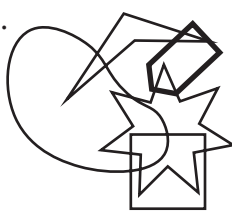

D.

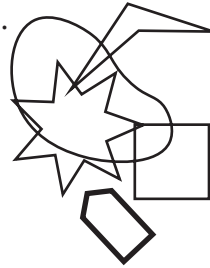

E.

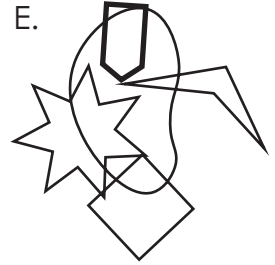

48.

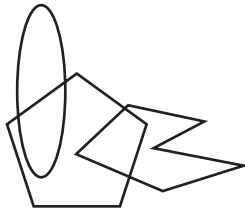

and

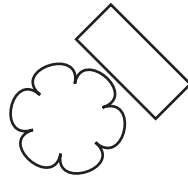

A.

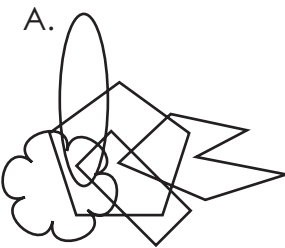

B.

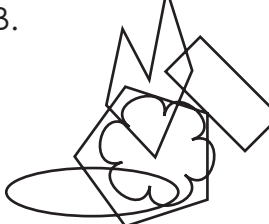

C.

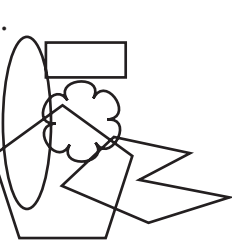

D.

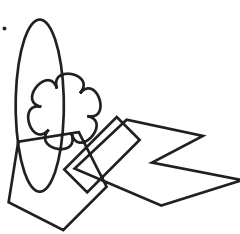

E.

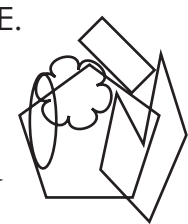

49.



and



A.



B.



C.

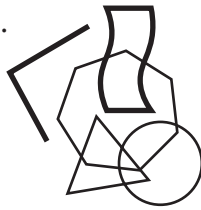

D.



E.



50.



and



A.

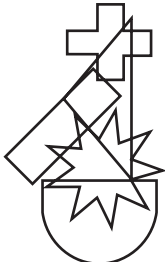

B.

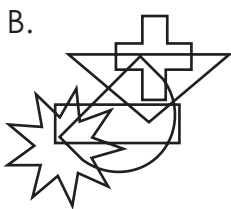

C.

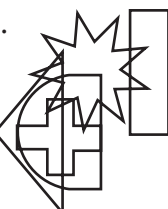

D.



E.

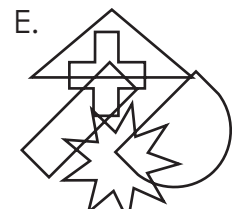



Which composite shape is created when all the shapes are joined by the corresponding letters?

51.

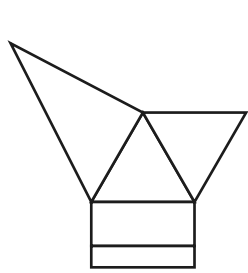
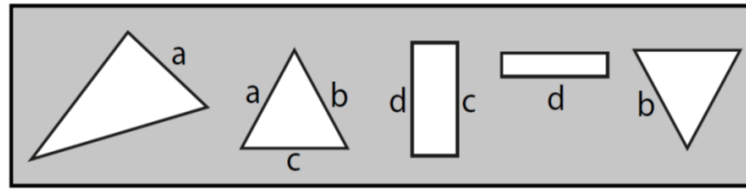

A

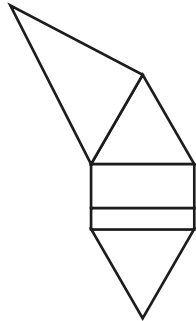

B

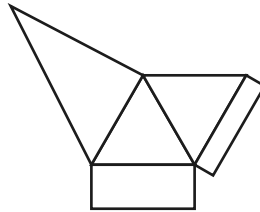

C

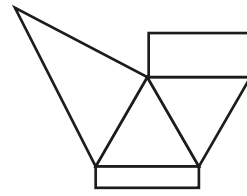

D

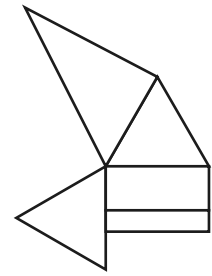

E

52.

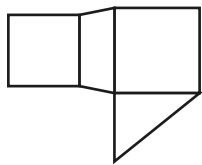
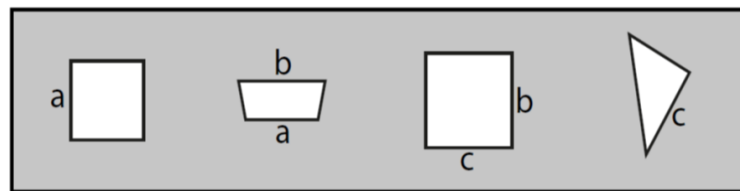

A

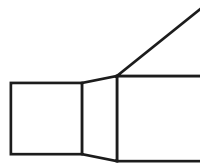

B

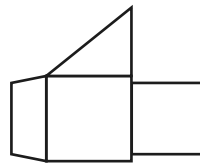

C

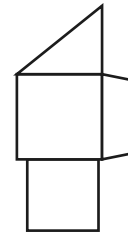

D

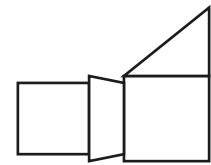

E

53.

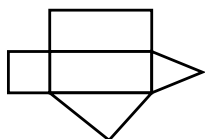
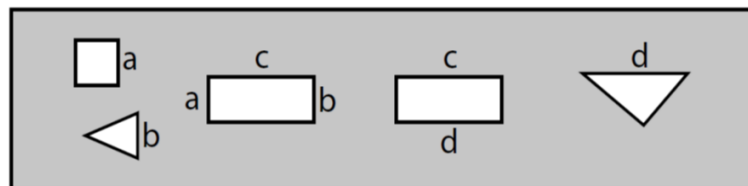

A

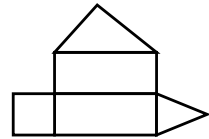

B

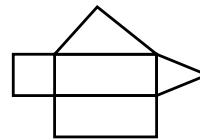

C

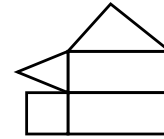

D

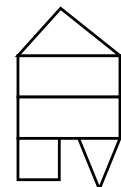

E





54.

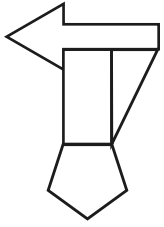
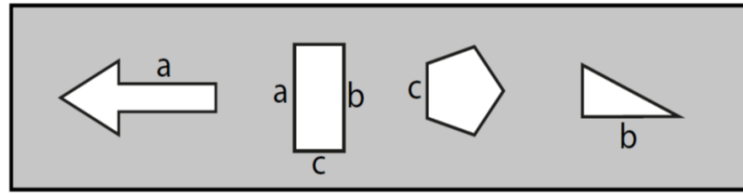

A

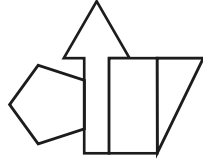

B

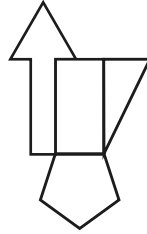

C



D

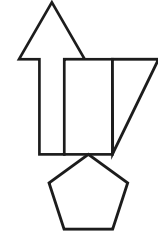

E

55.

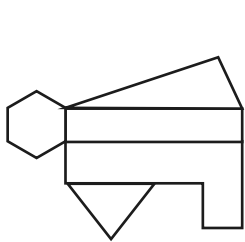
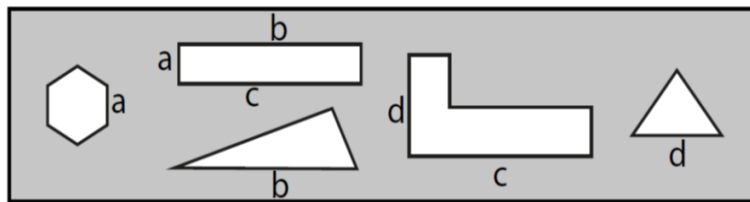

A

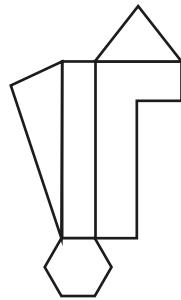

B

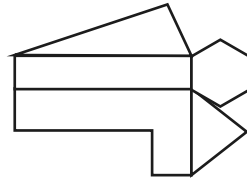

C

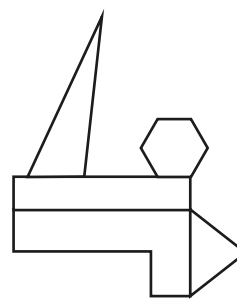

D

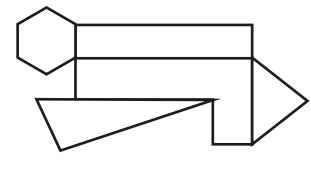

E

Which option is a plan view of the 3D shape on the left?

56.

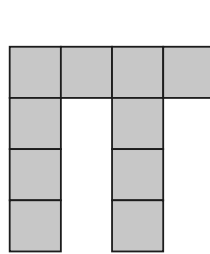
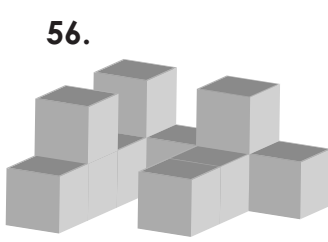

A

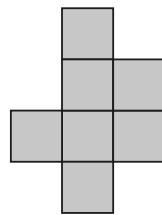

B

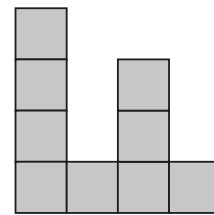

C

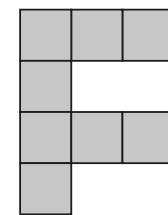

D

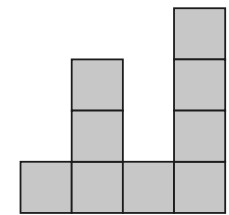

E

57.

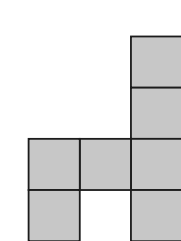
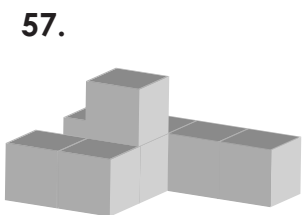

A



B



C

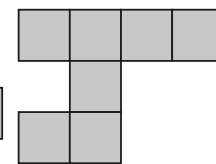

D

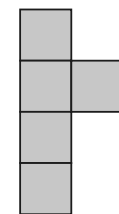

E





58.

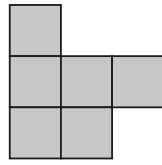
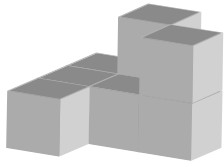

A

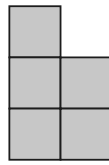

B

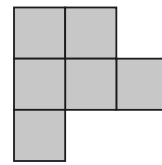

C

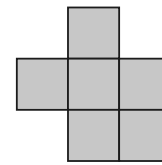

D

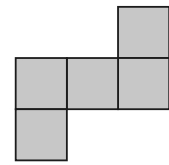

E

59.

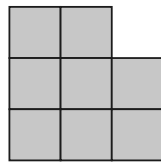
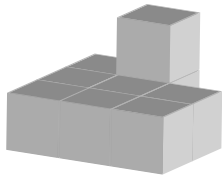

A

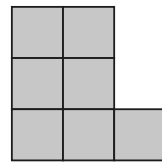

B

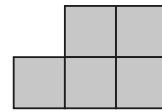

C

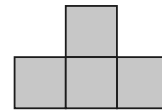

D

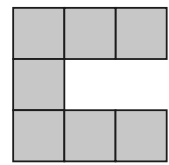

E

60.

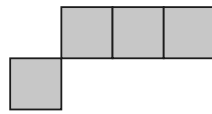
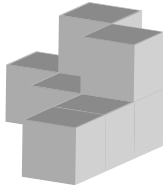

A

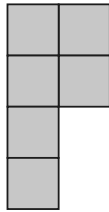

B

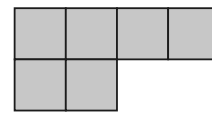

C

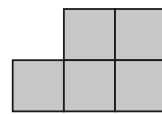

D

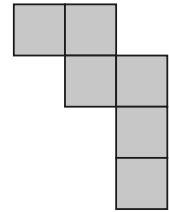

E

END OF SECTION 3







**Section 4 – You have 10 minutes to complete this section**

Look at the net on the left. Which cube matches the net?

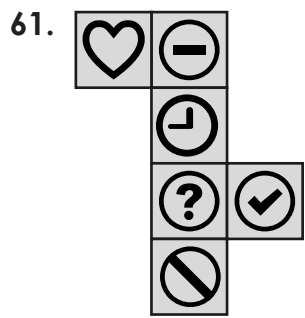

A



B



C

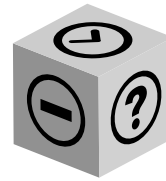

D

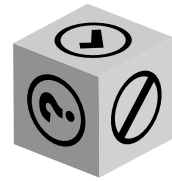

E

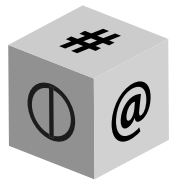
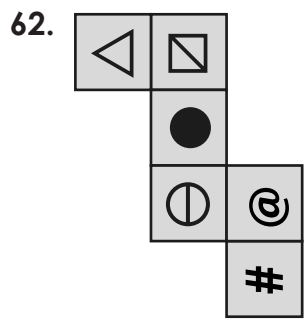

A

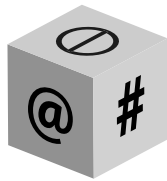

B

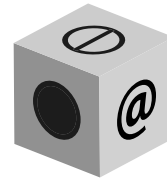

C

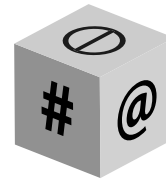

D

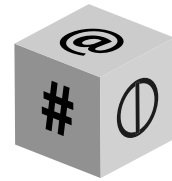

E

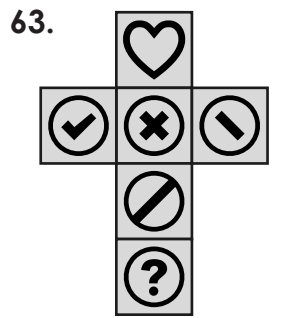

A



B



C

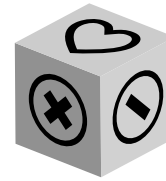

D



E

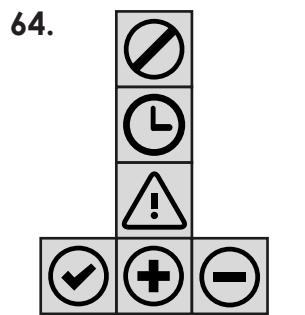

A

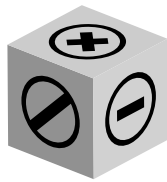

B



C



D

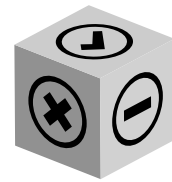

E





65.

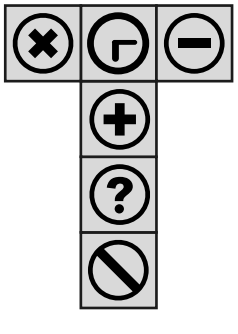

A



B



C

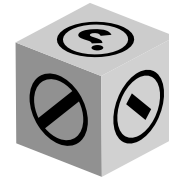

D



E

Look at the folded piece of paper with holes punched in it. Which option shows what the paper will look like when it is unfolded?

66.

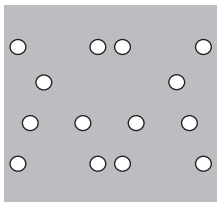
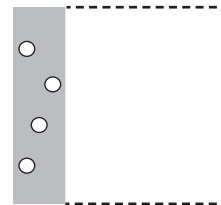
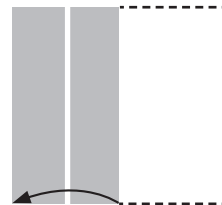
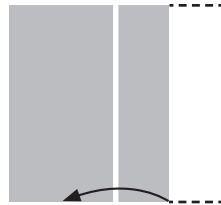
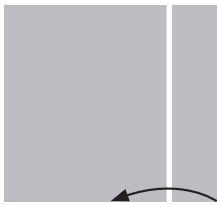

A

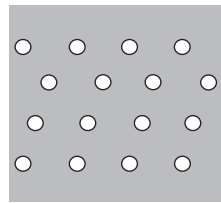

B

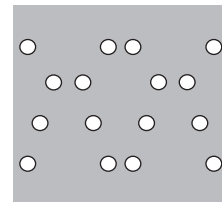

C

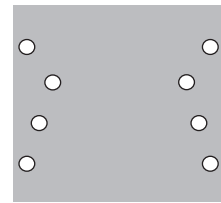

D

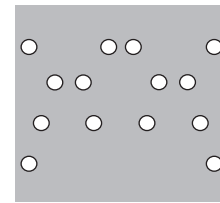

E

67.

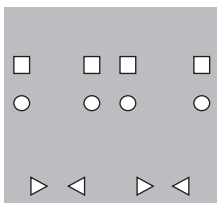
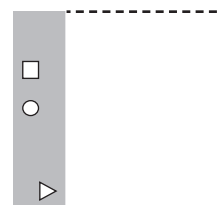
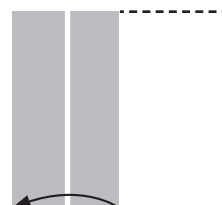
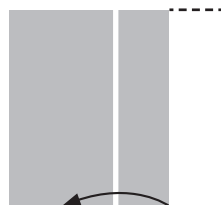
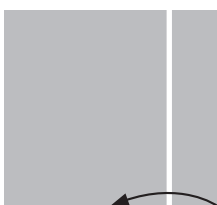

A

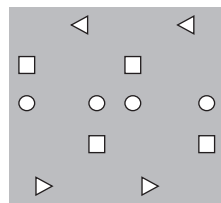

B

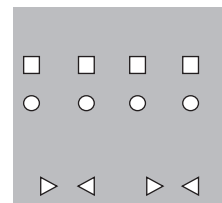

C

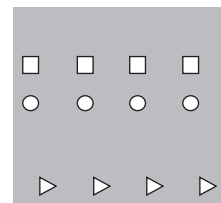

D

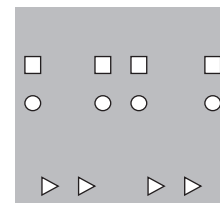

E





68.

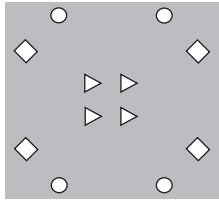
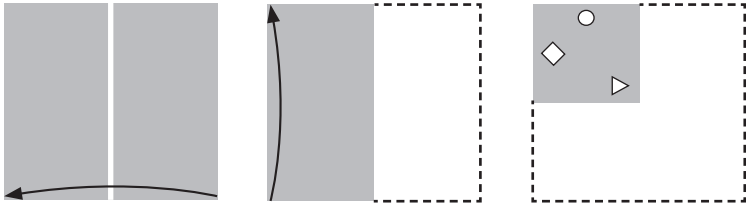

A

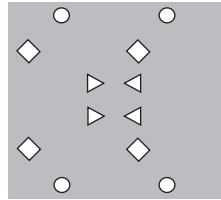

B

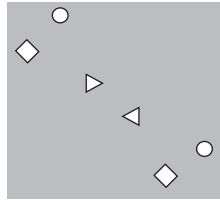

C

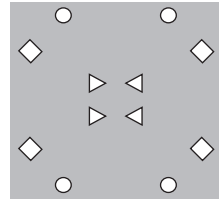

D

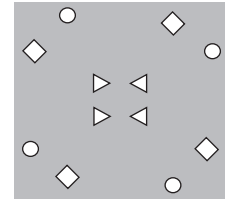

E

69.

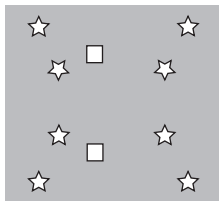
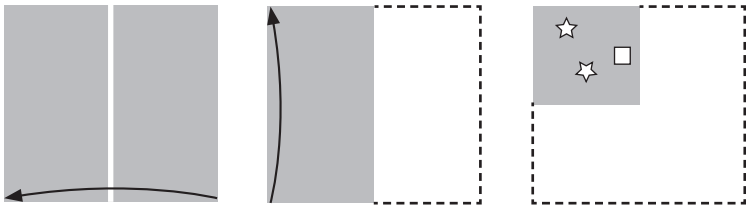

A

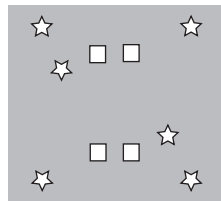

B

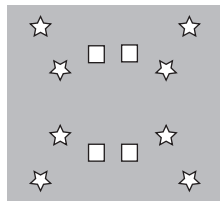

C

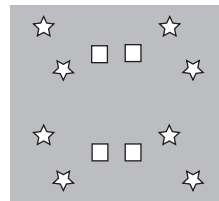

D

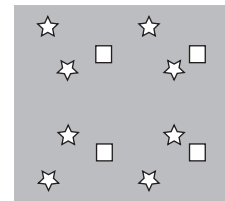

E

70.

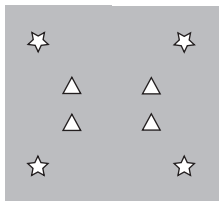
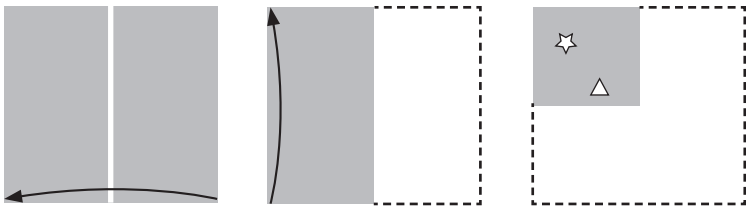

A

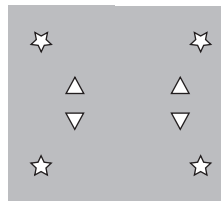

B

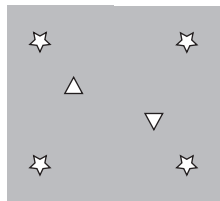

C

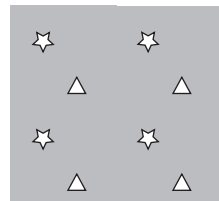

D

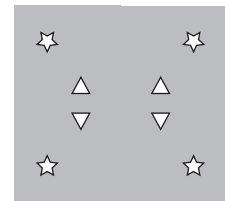

E





Look at the shape on the left. Identify the identical shape on the right.

71.



A



B



C



D



E

72.

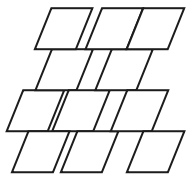
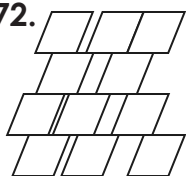

A

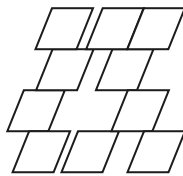

B

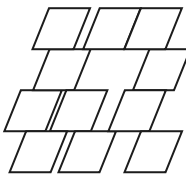

C

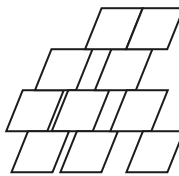

D

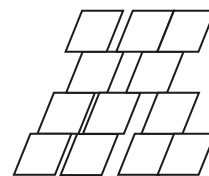

E

73.

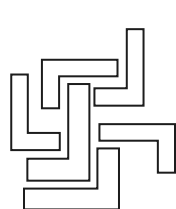
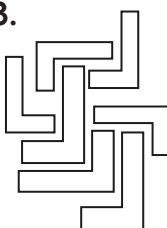

A

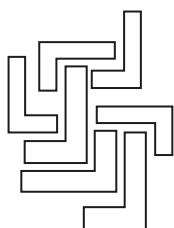

B

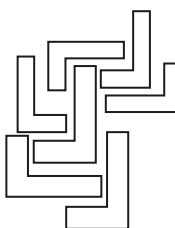

C

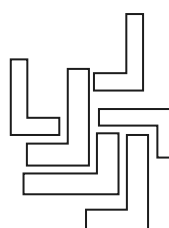

D

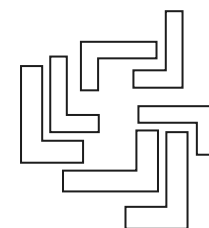

E

74.

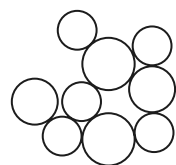
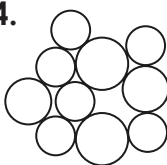

A

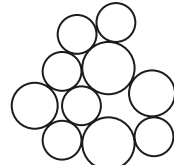

B

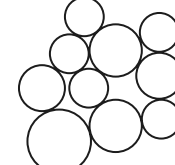

C

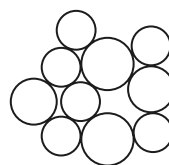

D

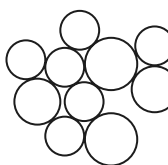

E

75.

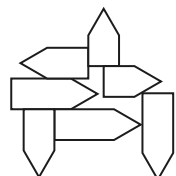
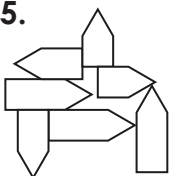

A

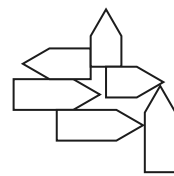

B

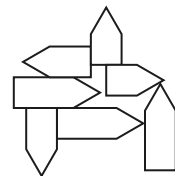

C

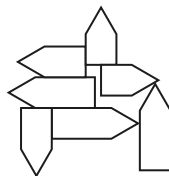

D

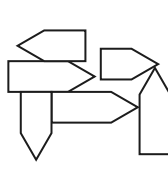

E

76.

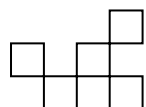
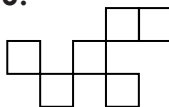

A

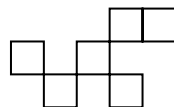

B

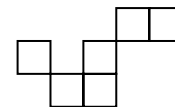

C

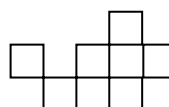

D

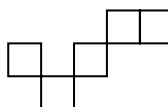

E

77.



A



B

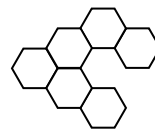

C



D



E



78. Which shape in Group 2 corresponds to shape number 18 from Group 1?

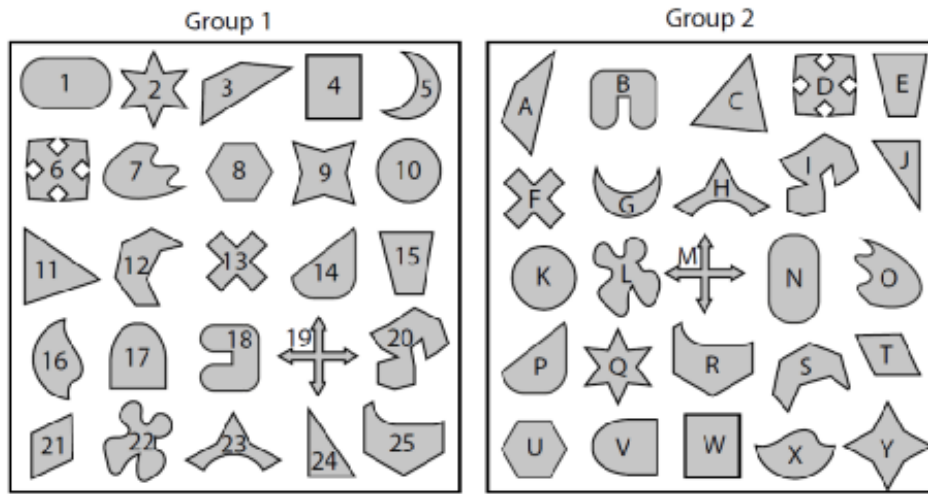

- A. V      B. D      C. U      D. B      E. Y

79. Which shape in Group 2 corresponds to shape number 21 from Group 1?

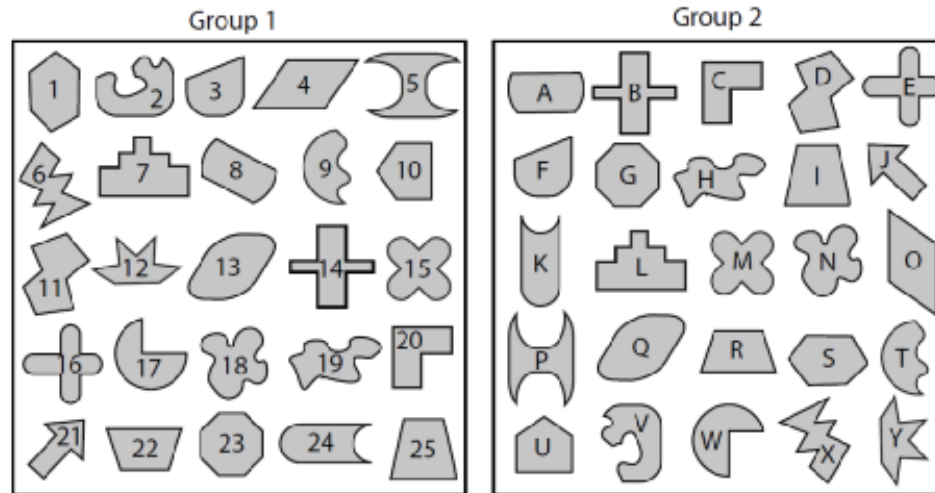

- A. I      B. J      C. L      D. X      E. Y

80. Which shape in Group 2 corresponds to shape number 22 from Group 1?

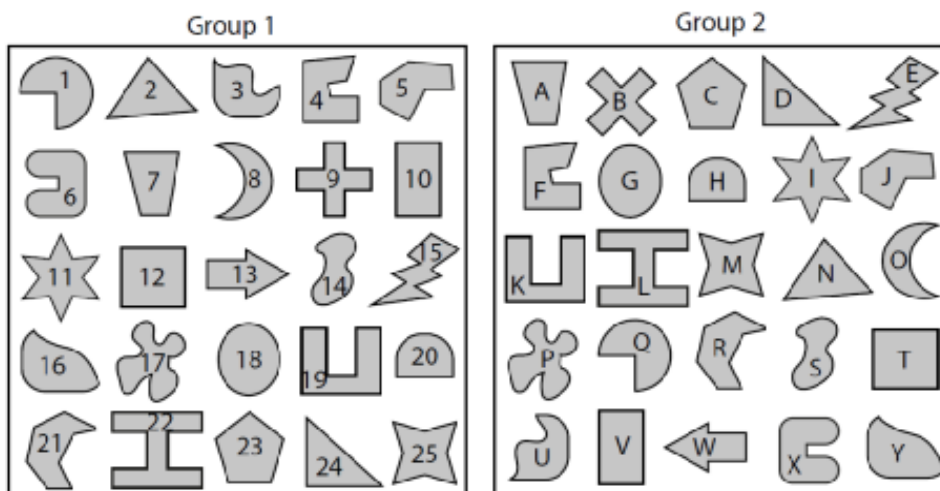

- A. L      B. F      C. K      D. X      E. B

**END OF SECTION 4**



# SELF REFLECTION

Take some time to reflect on your review test experience. Although they may sometimes feel stressful, exams can also be valuable learning opportunities.

## Your preparation

How confident did you feel going into the exam?



Did you prepare / revise for the test in any way?

---

---

## Your performance

Did you understand and follow the instructions given for the exam?

<input type="checkbox"/>	<input type="checkbox"/>
yes	no

Did you have enough time to answer all the questions in the exam?

<input type="checkbox"/>	<input type="checkbox"/>
yes	no

Which topics were you most confident answering?

---

---

Which topics were you least confident answering?

---

---

What emotions did you feel during the exam?

---

---

## What might you do differently next time?

In preparation for your next exam, write down one thing you will keep doing and one thing you will change for next time.

Keep	Change

# Mock Paper B – Maths

**Read the instructions carefully.**

1. Write your answer for each question on the line provided, or circle the correct answer when you are given answer options.
2. You will have **50 minutes to answer 50 questions**.
3. You may find some of the questions difficult. If you cannot do a question, do not waste time on it, but go on to the next questions. If you are not sure of an answer, choose the one you think is best.
4. Work as quickly and as carefully as you can.
5. Make sure you can see a clock.
6. Allocate enough time to check your answers at the end.

1. What is the value of 3 in 3,285,421?

**Answer:** \_\_\_\_\_

2. What is the highest common factor (HCF) of 30 and 40?

**Answer:** \_\_\_\_\_

3. Which shows  $4\frac{2}{5}$  as a mixed number?

A.  $8\frac{1}{5}$       B.  $7\frac{2}{5}$       C.  $8\frac{3}{5}$       D.  $8\frac{2}{5}$       E.  $9\frac{3}{5}$

4. Which of these fractions has the lowest value?

A.  $\frac{7}{8}$       B.  $\frac{3}{4}$       C.  $\frac{1}{4}$       D.  $\frac{1}{2}$       E.  $\frac{1}{8}$

5. 32 pints = ? gallons

**Answer:** \_\_\_\_\_gallons

6. Using the conversion table, convert the distance between the two houses from miles to km.



**Answer:** \_\_\_\_\_km

7. What is  $1.3\text{ l} - 1\text{ l}$ ?

**Answer:** \_\_\_\_\_ml

8. Round this number to the nearest whole number.

**2.812**

**Answer:** \_\_\_\_\_

9. If a coin is thrown 56 times, how many times is it likely to land on heads?

**Answer:** \_\_\_\_\_



10. Write  $\frac{45}{5}$  as a percentage.

**Answer:** \_\_\_\_\_%

11. Write 28% as a fraction in its simplest form.

**Answer:** \_\_\_\_\_

12. What is the missing prime factor of 40?

$$2 \times 2 \times 2 \times ?$$

**Answer:** \_\_\_\_\_

13. There are 400 books in the school library and 160 of them are non-fiction. What percentage are fiction?

**Answer:** \_\_\_\_\_%

14. This tally chart shows the results of a poll in a magazine for dog lovers. It asked people to vote for their favourite breed.

What is the difference in the number of votes between Labrador and Alsatian?

Type of Dog	Number of people
Spaniel	
Poodle	
Labrador	
Alsatian	
Yorkshire Terrier	

**Answer:** \_\_\_\_\_

15. Here are the number of shells Darcey collected from the beach over a week. What is the median?

**8, 9, 13, 8, 12, 13, 12**

**Answer:** \_\_\_\_\_

16. What is the lowest common multiple of 6 and 9?

**Answer:** \_\_\_\_\_

17. Multiply 0.2 by 24.

**Answer:** \_\_\_\_\_

18. At a GP clinic two doctors can see eight patients in an hour. How many patients can four doctors see in 30 minutes?

**Answer:** \_\_\_\_\_

19. Paul bought a book from the book shop, which cost £6.23. How much change did Paul get back if he paid with a £20 note?

**Answer:** £ \_\_\_\_\_

20. A box contains 2 red pens, 3 blue pens and 4 black pens. A pen is picked at random. What is the probability of picking a black pen?

A. 0

B.  $\frac{2}{9}$

C.  $\frac{4}{9}$

D.  $\frac{7}{9}$

E. 1

21. Ottoline threw a ball into the air three times. The first time she threw the ball 1.798 metres into the air. The second time she threw it 2.005 metres in the air and then the third time she threw it 1.998 metres into the air. What was the difference between her highest and lowest throw?

**Answer:** \_\_\_\_\_ metres

22. Find 28% of 200.

**Answer:** \_\_\_\_\_

23. What is the difference between the highest and lowest number of delays?

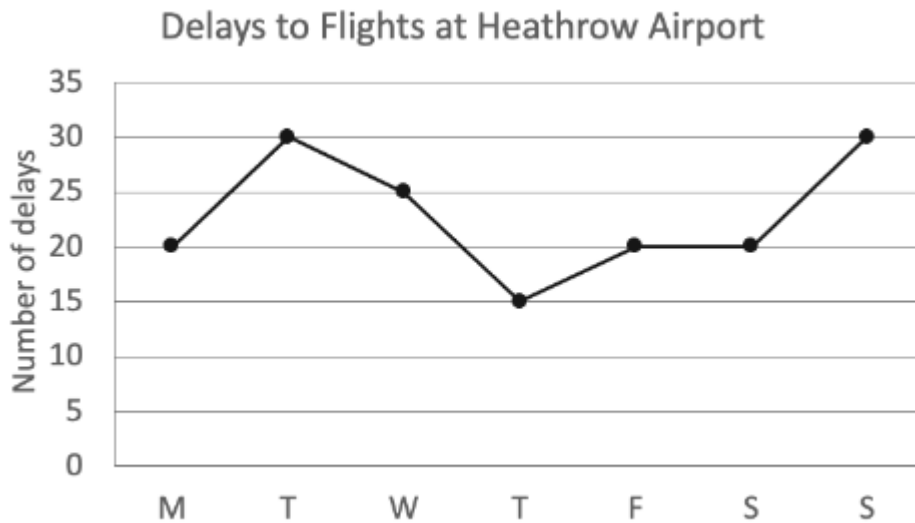

**Answer:** \_\_\_\_\_

24. Some adults were asked which countries they have visited.

Here is a Venn diagram showing the situation. How many adults visited France?

**G = Germany and F = France**

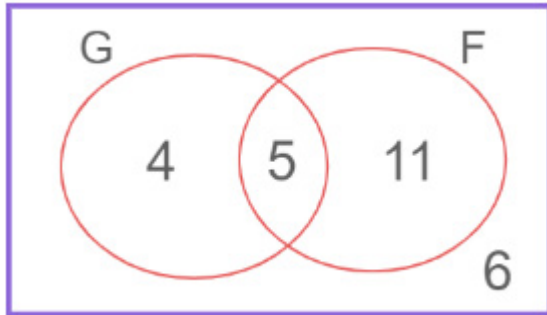

**Answer:** \_\_\_\_\_

25. A class of thirty students take a test. If five sixths of the class pass, how many students need to retake the test?

**Answer:** \_\_\_\_\_

26. If Fiona gets a full book of stickers for good behaviour from school, she will get a treat from her Mum. There are eight pages in a book and 20 stickers per page. If Fiona can earn a maximum of four stickers a day at school, what is the shortest amount of days at school before she can get her treat?

**Answer:** \_\_\_\_\_ days

27. The ratio of blue and black pens in the pen box is 3:4. There are 60 blue pens. How many black pens are there?

**Answer:** \_\_\_\_\_

28. Find the number that continues the sequence in the most sensible way.

**222, ?, 112, 72, 42, 22**

**Answer:** \_\_\_\_\_

29. Simplify the following expression:

**$2c + a - c$**

A.  $2c + a$       B.  $c + a$       C.  $2c + c$       D.  $c$       E.  $a$

30. Which is the numeral for five million, four hundred thousand and one?

A. 5,004,001      B. 5,400,001      C. 540,001      D. 5,000,401      E. 54,001

31. If a rectangle was drawn on the graph below and three of its vertices were (3,4), (8,4) and (3,7). What are the coordinates of the missing vertex?

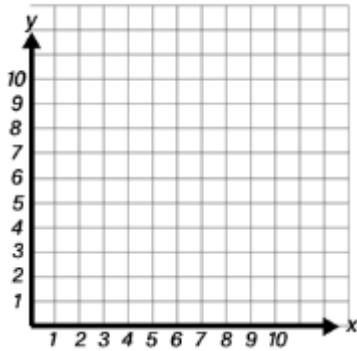

- A. (8, 8)      B. (8, 7)      C. (3, 8)      D. (4, 8)      E. (8, 3)

32. What are the coordinates of the HSS Minor?

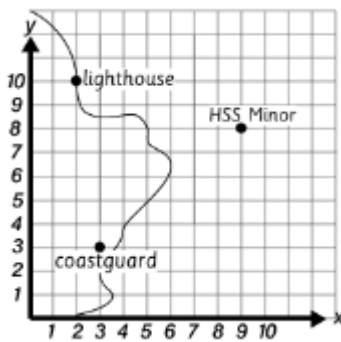

Answer: \_\_\_\_\_

33. Find the number that continues the series in the most sensible way.

13, 15, 18, 22, 27, ?

Answer: \_\_\_\_\_

34.  $a = 4$ ,  $b = 2$  and  $c = 8$

$3a + 5b - c = ?$

Answer: \_\_\_\_\_

35. A plastic container holds 1.7 litres and a bottle holds 1150ml. What is the difference in the capacity of the plastic container and the bottle?

Answer: \_\_\_\_\_ ml

36. One small cube has a volume of  $3\text{cm}^3$ . If a larger cube is made up of 16 of the smaller cubes, what will the volume of the larger cube be?

Answer: \_\_\_\_\_  $\text{cm}^3$

37. Find the number that continues the sequence in the most sensible way.

2, 4, 12, 48, 240, ?

Answer: \_\_\_\_\_

38. If this pentagonal prism has a length of 14cm and its pentagonal face has an area of  $25\text{cm}^2$ , what is its volume?

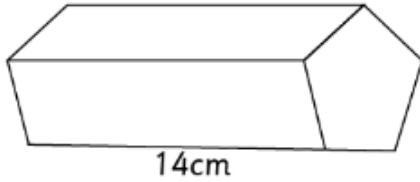

Answer: \_\_\_\_\_  $\text{cm}^3$

39. Write an equation that says that the length of the blue line on top is the same as the length of the black line at the bottom.

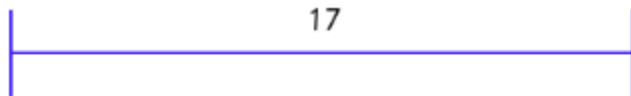

- A.  $17 + 16 = y$     B.  $17 = 16 + y$     C.  $y + 17 = 16$     D.  $17 - y = 6$     E.  $6 + 1 = 7$

40. Which of the following letters has no lines of symmetry?

- A. T    B. Q    C. X    D. O    E. Y

41. What is the order of rotational symmetry of this shape?

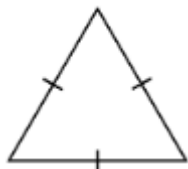

- A. 0    B. 5    C. 3    D. 1    E. 2

42. My dad was born in MCMLXX. What year was he born?

- A. 2000    B. 1970    C. 1963    D. 1982    E. 1980

43. Which of these is the next triangular number?

1, 3, 6, 10, 15, 21, ?

- A. 26    B. 28    C. 36    D. 40    E. 45

44. What is the next square number?

**25, 36, 49, ?**

- A. 64                      B. 62                      C. 58                      D. 56                      E. 52

45. What is the mean of this set of numbers?

**22, 43, 17, 10, 9, 35, 11**

**Answer:** \_\_\_\_\_

46. Suzie is 12 and Angela is 8. Their aunt gives them £60 to be shared in the ratio of their ages. How much will Angela get?

**Answer:** £ \_\_\_\_\_

47. Rachel drew a picture of the school playground using a scale of 1 cm to 10m. On the plan the playground is 4cm long. What is the real length of the playground?

**Answer:** \_\_\_\_\_m

48. Here are the scores of a contest:

Contest Scores									
10,	11,	11,	12,	13,	14,	14,	14,	14,	15

What is the mode of these scores?

**Answer:** \_\_\_\_\_

49. Here is a coach timetable.

Explore Travel – coach timetable			
London	07:30	10:30	13:30
Chelmsford	09:02	12:05	15:06
Ipswich	10:18	13:20	16:25
Norwich	12:05	15:08	18:15

Sid is planning to catch the 13:30 coach from London to Ipswich.

The coach arrived in Ipswich 25 minutes late and it took Sid 12 minutes to reach his final destination.

At what time did Sid arrive? Give your answer using the 24-hour clock.

**Answer:** \_\_\_\_\_

50. This pie chart shows the number of children who go to different after-school clubs on Mondays. Green is Art, Blue is Choir and Yellow is Football.

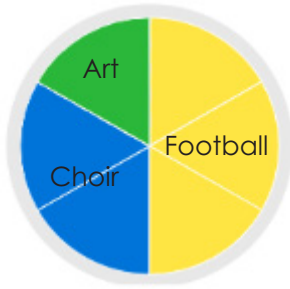

There are 24 children who go to Football club.

How many children go to Art club on Monday?

**Answer:** \_\_\_\_\_

# Mock Paper B – English

**Read the instructions carefully.**

1. You have a passage to read and then answer some questions about it. You can look back at the passage to check your answers as many times as you want.
2. There are three sections of spelling, punctuation and grammar exercises to do.
3. Write your answer for each question on the line provided, or circle the correct answer when you are given answer options.
4. You have **50 minutes to answer 56 questions**.
5. You may find some of the questions difficult. If you cannot do a question, do not waste time on it, but go on to the next questions. If you are not sure of an answer, choose the one you think is best.
6. Work as quickly and as carefully as you can.
7. Make sure you can see a clock.
8. Allocate enough time to check your answers at the end.





**Read the extract from *Jo's Boys* by Louisa M. Alcott then answer the questions that follow.**

This was the beginning of the summer holiday, and it was curious to see what a pleasant little stir Dan's and Emil's coming made in the quiet life of the studious community; for they seemed to bring a fresh breeze with them that enlivened everyone. Many of the collegians remained during vacation; and Plumfield and Parnassus did their best to make these days  
5 pleasant for them, since most came from distant States, were poor, and had few opportunities but this for culture or amusement. Emil was hail-fellow-well-met with men and maids, and went rollicking about in true sailor fashion; but Dan stood rather in awe of the 'fair girl-graduates', and was silent when among them, eyeing them as an eagle might a flock of doves. He got on better with the young men, and was their hero at once. Their  
10 admiration for his manly accomplishments did him good; because he felt his educational defects keenly, and often wondered if he could find anything in books to satisfy him as thoroughly as did the lessons he was learning from Nature's splendidly illustrated volume. In spite of his silence, the girls found out his good qualities, and regarded 'the Spaniard', as they named him, with great favour; for his black eyes were more eloquent than his tongue,  
15 and the kind creatures tried to show their friendly interests in many charming ways.

He saw this, and endeavoured to be worthy of it—curbing his free speech, toning down his rough manners, and watching the effect of all he said and did, anxious to make a good impression. The social atmosphere warmed his lonely heart, the culture excited him to do his best, and the changes which had taken place during his absence, both in himself and  
20 others, made the old home seem like a new world. After the life in California, it was sweet and restful to be here, with these familiar faces round him, helping him to forget much that he regretted, and to resolve to deserve more entirely the confidence of these good fellows, the respect of these innocent girls.

So there was riding, rowing, and picnicking by day, music, dancing, and plays by night;  
25 and everyone said there had not been so gay a vacation for years. Bess kept her promise, and let the dust gather on her beloved clay while she went pleasuring with her mates or studied music with her father, who rejoiced over the fresh roses in her cheeks and the laughter which chased away the dreamy look she used to wear. Josie quarrelled less with Ted; for Dan had a way of looking at her which quelled her instantly, and had  
30 almost as good an effect upon her rebellious cousin. But Octoo did even more for the lively youth, who found that her charms entirely eclipsed those of the bicycle which had been his heart's delight before. Early and late he rode this untiring beast, and began to gain flesh—to the great joy of his mother, who feared that her beanstalk was growing too fast for health.

Demi, finding business dull, solaced his leisure by photographing everybody he could induce to sit or stand to him, producing some excellent pictures among many failures; for he had a pretty taste in grouping, and endless patience. He might be said to view the world through the lens of his camera, and seemed to enjoy himself very much squinting at his fellow beings from under a bit of black cambric. Dan was a treasure to him; for he took  
40 well, and willingly posed in his Mexican costume, with horse and hound, and all wanted copies of these effective photographs. Bess, also, was a favourite sitter; and Demi received a prize at the Amateur Photographic Exhibition for one of his cousin with all her hair about her face, which rose from the cloud of white lace draping the shoulders. These were freely handed round by the proud artist; and one copy had a tender little history yet to be told.





## Section 1

1. What was the impact of Dan's and Emil's arrival on the community during summer vacation?

---

---

---

2. Choose one alternative word for the word 'rejoiced', as used in the context of the text.

- A cried
- B loving
- C delighted
- D devastation
- E pained

3. How did Emil behave among the students during the vacation?

---

---

---

4. How did Dan feel about the 'fair girl-graduates'?

---

---

---





5. Why did Dan try to curb his free speech and tone down his rough manners?

---

---

---

6. How did the social atmosphere affect Dan?

---

---

---

7. What hobby did Demi take up during the vacation?

---

---

8. What is the below quote an example of?

**'Plumfield and Parnassus did their best'**

- A alliteration
- B an idiom
- C personification
- D a rhetorical question
- E imagery





9. In paragraph three, what three things are said to be done in the day?

---

---

---

10. Choose one alternative word for the word 'rebellious', as used in the context of the text.

- A docile
- B submissive
- C excitable
- D pretentious
- E defiant

11. What time of year is this passage set?

---

---

12. In the below quote, which word is a proper noun?

**'After the life in California, it was sweet and restful to be here...'**

- A sweet
- B California
- C here
- D be
- E After





**13.** Choose one alternative word for the word 'eclipsed', as used in the context of the text.

- A** outshone
- B** inshined
- C** created
- D** forgotten
- E** fought

**14.** Select the correct meaning of the word 'patience'.

- A** An act of resigning from a job or office.
- B** Allow oneself to enjoy the pleasure of.
- C** Having or showing a friendly, generous, and considerate nature.
- D** The ability to accept delay, suffering, or annoyance without complaining or becoming angry.
- E** Generous in giving to those in need.

**15.** How did the girls view Dan, and what nickname did they give him?

---

---

---

**16.** Select the correct meaning of the word 'defects'.

- A** A shortcoming, imperfection or lack.
- B** A narrow space between two surfaces that have broken or been moved apart.
- C** An allotted place in an arrangement or scheme.
- D** Cause (someone) to deviate from an intended purpose.
- E** Prevent (someone) from concentrating on something.





17. For what did Demi receive a prize for at the Amateur Photographic Exhibition?

---

---

---

18. Why was Octoo important to Ted during the vacation?

---

---

---

19. What did Josie and Ted quarrel less about during the vacation?

---

---

---

20. Select the correct meaning of the word '**quelled**'.

- A Subdue or silence (someone).
- B Resolve or reach an agreement about (an argument or problem).
- C Fasten (something) securely in a particular place or position.
- D (Of lines) tend to meet at a point.
- E Bring together or into contact so that a real or notional link is established.



## Spelling Exercise

This exercise contains **spelling** mistakes. On each numbered line there is either **one** mistake or **no mistake**. Find the group of words with the mistake in it and mark its letter on your answer sheet. **If there is no mistake, mark N.**

21. Tyla went to the hairdresser to get her hair cut. She had two inches taken off.

A	B	C	D	N
---	---	---	---	---

22. I needed to go to the library to save a few files that I need for school.

A	B	C	D	N
---	---	---	---	---

23. Four thieves broke into my friend's house this weekend and took their necklace.

A	B	C	D	N
---	---	---	---	---

24. When I went to the dentist, the dentist said my teeth were very clean.

A	B	C	D	N
---	---	---	---	---

25. My friend Jerry likes to crack his knuckles and it makes a horrid noise!

A	B	C	D	N
---	---	---	---	---

26. Our downstairs toilet was overflowing so we had to call a plumber.

A	B	C	D	N
---	---	---	---	---

27. My dad enjoys reading the sports column in the newspaper every Saturday.

A	B	C	D	N
---	---	---	---	---

28. Yara fought for what she thought was right and went to the protest alone.

A	B	C	D	N
---	---	---	---	---

29. Chlorophyll is the substance that gives green plants their colour.

A	B	C	D	N
---	---	---	---	---



30. The dancers practised every day until they synchronised their movements.

A	B	C	D	N
---	---	---	---	---

31. The bees decided to have a mutiny against their queen.

A	B	C	D	N
---	---	---	---	---





## Punctuation Exercise

In this exercise there are some mistakes in the use of **punctuation**. On each numbered line there is either **one** mistake or **no mistake**. Find the group of words with the mistake in it and mark its letter on your answer sheet. **If there is no mistake, mark N.**

32. After the movie, we went, to the nearby café for some snacks.

A	B	C	D	N
---	---	---	---	---

33. "Make a move—and fast!" said Gerry, who thought the monster was near.

A	B	C	D	N
---	---	---	---	---

34. The cat, who often causes trouble knocked over the vase.

A	B	C	D	N
---	---	---	---	---

35. He had many hobbies: such as painting, playing the guitar and hiking.

A	B	C	D	N
---	---	---	---	---

36. When I go to bed in the evening, I like to read a book to relax and unwind

A	B	C	D	N
---	---	---	---	---

37. It is important to keep your eye on the prize if you want to win?

A	B	C	D	N
---	---	---	---	---

38. Lets meet up for dinner next week because I'm going to be in town!

A	B	C	D	N
---	---	---	---	---

39. On the farm I visited, a gold ring dangled from a cow's nose.

A	B	C	D	N
---	---	---	---	---

40. Remember to bring the essentials for the trip: sunscreen and your passport.

A	B	C	D	N
---	---	---	---	---



41. She wanted to buy the following items - eggs, milk, bread and cheese.

A	B	C	D	N
---	---	---	---	---

42. I wanted to go to the grocery store today. (It was closed for renovations).

A	B	C	D	N
---	---	---	---	---

43. For my snack, my brother packed me an apple some crisps and a drink.

A	B	C	D	N
---	---	---	---	---



## Grammar Exercise

In this exercise, choose the correct word or short phrase to complete each sentence. Each sentence must make sense and use Standard English.

44. I wish I had \_\_\_\_\_ how cold it was going to be before coming.  
A. know      B. knew      C. known      D. now      E. new
45. We \_\_\_\_\_ all going to watch the Christmas lights being turned on tonight.  
A. where      B. were      C. wear      D. we're      E. was
46. Hopefully \_\_\_\_\_ are going to enjoy the swimming pool tomorrow.  
A. their      B. there      C. they're      D. they      E. the
47. Queen Elizabeth II's \_\_\_\_\_ lasted from the industrial age to the Internet age.  
A. rain      B. ren      C. wren      D. rein      E. reign
48. On Sports Day, Maya \_\_\_\_\_ the ball as far as she could!  
A. through      B. thorough      C. threw      D. throw      E. throne
49. The day after my birthday, I used my money to \_\_\_\_\_ some toys.  
A. buy      B. bye      C. by      D. bi      E. bide
50. Can you please go to the kitchen and \_\_\_\_\_ me a glass of squash?  
A. pore      B. pour      C. paw      D. poor      E. pair

**Identify the part of the sentence that contains the object.**

51. They bought a new shiny laptop yesterday to use for studying.

A	B	C	D	N
---	---	---	---	---

52. My friend Freda placed her new book on the wooden table.

A	B	C	D	N
---	---	---	---	---

**Identify the part of the sentence that contains an adverb.**

53. The police officer told the person in the blue car to stop driving fast.

A	B	C	D	N
---	---	---	---	---

54. I need to drink my tea quite quickly as I have a train to catch.

A	B	C	D	N
---	---	---	---	---

**Identify the part of the sentence that contains a pronoun.**

55. Tom was working hard to complete a coding course, which he enjoyed a lot.

A	B	C	D	N
---	---	---	---	---

56. The boy tried on the shorts and looked at himself in the mirror.

A	B	C	D	N
---	---	---	---	---

## Mock Paper B – VR

### Read the instructions carefully.

1. This is a multiple-choice paper.
2. The paper contains a number of different types of question. Each question types starts with an explanation of what to do.
3. Some questions require more than one answer to be marked. Read the instructions carefully.
4. Circle the correct answer or answers.
5. You have **60 minutes to answer 80 questions**.
6. You may find some of the questions difficult. If you cannot do a question, do not waste time on it, but go on to the next questions. If you are not sure of an answer, choose the one you think is best.
7. Work as quickly and as carefully as you can.
8. Make sure you can see a clock.
9. Allocate enough time to check your answers at the end.



In the questions below, move **one** letter from the word on the left to the word on the right, to create **two** new words. The letters **must not** be rearranged. Both new words must make sense. Choose the letter that moves.

1. feast                      palm  
A. f                      B. e                      C. a                      D. s                      E. t
  
2. wheat                      corn  
A. w                      B. h                      C. e                      D. a                      E. t
  
3. court                      vice  
A. c                      B. o                      C. u                      D. r                      E. t
  
4. clean                      plum  
A. c                      B. l                      C. e                      D. a                      E. n
  
5. stage                      sock  
A. s                      B. t                      C. a                      D. g                      E. e
  
6. abroad                      rise  
A. a                      B. b                      C. r                      D. o                      E. d
  
7. mainly                      char  
A. m                      B. a                      C. i                      D. n                      E. l

Find the pair of letters that continues the series in the most sensible way. Choose one pair from the answers below.

**A B C D E F G H I J K L M N O P Q R S T U V W X Y Z**

8. CD, RG, HK, YP, QV, ?  
A. JC                      B. KD                      C. KC                      D. IC                      E. ID





9. TE, UG, WJ, ZN, DS, ?  
A. JV                      B. IX                      C. PR                      D. IY                      E. CT
10. DB, FE, JJ, PQ, XZ, ?  
A. JI                      B. HL                      C. HK                      D. IH                      E. KK
11. CI, OT, BF, PS, EG, ?  
A. UV                      B. VT                      C. TV                      D. VU                      E. TU
12. ER, FS, GT, HU, IV, ?  
A. KE                      B. JZ                      C. NI                      D. JW                      E. NP
13. VL, LW, CI, UV, NJ, ?  
A. GX                      B. GW                      C. HW                      D. HY                      E. FX
14. YE, OO, FZ, XL, QY, ?  
A. LM                      B. KN                      C. KM                      D. LL                      E. JN

Read the following information, then find the correct answer to the question.

15. Miguel is at a baseball game at a large stadium. The stadium's total capacity is 50,000 seats. During this game, 65% of the stadium's seats are occupied by fans. How many seats are occupied by fans?  
A. 35,000                      B. 33,750                      C. 32,500                      D. 34,000                      E. 32,000
16. Emily, Jack, Sarah and Liam participated in an art competition. They all painted beautiful pictures. Emily painted two more pictures than Jack. Liam painted three fewer pictures than Emily. Sarah painted the same number of pictures as Emily. Jack painted 10 pictures. Who painted fewer pictures than Jack?  
A. Emily                      B. Jack                      C. Sarah                      D. Liam                      E. Nobody
17. Maya's watch is 7 minutes slow. Her appointment, which should have started at 15:45, is running 10 minutes late. What time does Maya's watch show when the appointment starts?  
A. 15:55                      B. 16:02                      C. 15:42                      D. 15:48                      E. 15:28





Find the **two** words, one from each group, that are most similar in meaning. Select the **two** words from the options below.

**18.** (palatable, liked, odious) (abhorrent, sector, flavoured)

A. palatable X. abhorrent

B. liked Y. sector

C. odious Z. flavoured

**19.** (adroit, amateurish, industrial) (cooking, adept, revision)

A. adroit X. cooking

B. amateurish Y. adept

C. industrial Z. revision

**20.** (celebrate, melancholy, nostalgic) (happy, jovial, lugubrious)

A. celebrate X. happy

B. melancholy Y. jovial

C. nostalgic Z. lugubrious

**21.** (offensive, applause, courteous) (respectful, label, abhorrent)

A. offensive X. respectful

B. applause Y. label

C. courteous Z. abhorrent

**22.** (indulge, forgo, guile) (spoil, unemployed, condemn)

A. indulge X. spoil

B. forgo Y. unemployed

C. guile Z. condemn







23. (biblical, renounce, candour) (sincerity, chest, energetic)

- |             |              |
|-------------|--------------|
| A. biblical | X. sincerity |
| B. renounce | Y. chest     |
| C. candour  | Z. energetic |

24. (substantial, idle, obsession) (dynamic, vibrant, indolent)

- |                |             |
|----------------|-------------|
| A. substantial | X. dynamic  |
| B. idle        | Y. vibrant  |
| C. obsession   | Z. indolent |

Find **two** words, **one** from each group, that together make one correctly spelt word, without changing the order of the letters. The word from the first group always comes first.

25. (sing, via, short) (duct, lid, draw)

- |          |         |
|----------|---------|
| A. sing  | X. duct |
| B. via   | Y. lid  |
| C. short | Z. draw |

26. (down, stag, unit) (mate, hood, play)

- |         |         |
|---------|---------|
| A. down | X. mate |
| B. stag | Y. hood |
| C. unit | Z. play |

27. (work, port, attain) (bidden, point, end)

- |           |           |
|-----------|-----------|
| A. work   | X. bidden |
| B. port   | Y. point  |
| C. attain | Z. end    |





28. (chess, nation, discord) (course, ant, path)

- |            |           |
|------------|-----------|
| A. chess   | X. course |
| B. nation  | Y. ant    |
| C. discord | Z. path   |

29. (loath, liquid, phone) (ate, sand, show)

- |           |         |
|-----------|---------|
| A. loath  | X. ate  |
| B. liquid | Y. sand |
| C. phone  | Z. show |

30. (deter, had, new) (rent, unity, way)

- |          |          |
|----------|----------|
| A. deter | X. rent  |
| B. had   | Y. unity |
| C. new   | Z. way   |

31. (wrong, ball, addition) (yard, park, hard)

- |             |         |
|-------------|---------|
| A. wrong    | X. yard |
| B. ball     | Y. park |
| C. addition | Z. hard |

In the sentence below, one word in capitals has had **three consecutive letters taken out**. These three letters on their own make **one correctly spelt word**, without changing the order. Choose the three-letter word from the options below.

32. The cosy blanket wrapped around her, gave her a feeling of MTH on the chilly night.

- |        |        |        |        |        |
|--------|--------|--------|--------|--------|
| A. war | B. tar | C. spy | D. top | E. pry |
|--------|--------|--------|--------|--------|





**33.** Practising every day gave Mia an ADTAGE in the school spelling competition.

- A. van                  B. oat                  C. ant                  D. ego                  E. ewe

**34.** After winning the game, Alex's friends all ran to him and EMBRD him with joy.

- A. aim                  B. ant                  C. eat                  D. ace                  E. bet

**35.** A squirrel quickly ran up the tree and sat on a high BCH to eat its nut.

- A. ran                  B. yet                  C. wit                  D. tap                  E. jug

**36.** The brave explorers set off on a long VOY across the ocean to discover new lands.

- A. end                  B. ebb                  C. eat                  D. and                  E. age

**37.** During the video game, there was a GCH that made the character move in a funny way.

- A. how                  B. lit                  C. bop                  D. you                  E. cut

**38.** The beautiful rainbow gave Lily the INSPIION to paint a colourful picture.

- A. net                  B. hot                  C. rat                  D. lid                  E. hay

In the questions below, find the number that continues the series in the most sensible way.

**39.** 11, 45, 17, 39, 23, ?

- A. 33                  B. 29                  C. 37                  D. 41                  E. 27

**40.** 2, 5, 4, 10, 16, 20, ?

- A. 40                  B. 38                  C. 32                  D. 256                  E. 56

**41.** 11, 24, 14, 21, 17, ?

- A. 18                  B. 20                  C. 15                  D. 24                  E. 21





42. 19, 23, 29, 31, 37, ?

- A. 43                      B. 39                      C. 42                      D. 44                      E. 41

43. 8, 32, 12, 48, 28, ?

- A. 28                      B. 112                      C. 8                      D. 104                      E. 96

44. -25, -13, -16, -4, -7, ?

- A. -3                      B. -8                      C. 5                      D. 3                      E. 0

45. 6, 10, 15, 21, 28, ?

- A. 36                      B. 45                      C. 34                      D. 30                      E. 35

A **four-letter word** is hidden at the **end** of one word and the **beginning** of the next word in the sentence. Find the pair of words that contains the hidden word.

46. Sarah felt proud when she solved the maths problem all by herself.

- A. Sarah felt              B. proud when              C. she solved              D. the maths              E. by herself

47. Zara had a great idea to make a birdhouse for the back garden.

- A. Zara had              B. great idea              C. to make              D. a birdhouse              E. the back

48. Somewhere in the park, there was a hidden treasure waiting to be discovered.

- A. Somewhere in              B. the park              C. there was              D. a hidden              E. waiting to

49. The rocket soared high into the sky, leaving a trail of sparkles as it went.

- A. The rocket              B. soared high              C. sky leaving              D. of sparkles              E. it went

50. The lizard that can change its colour to blend in with its surroundings is a chameleon.

- A. lizard that              B. can change              C. colour to              D. blend in              E. with its





51. It's important to admit when you make a mistake so you can learn and do better next time.  
A. It's important    B. to admit    C. you make    D. mistake so    E. do better
52. We added lemonade and ice to our drinks to cool us down on the hot day.  
A. We added    B. and ice    C. our drinks    D. us down    E. hot day

In these question, letters stand for numbers. Use the code to work out the answer to the calculation. Choose the correct letter as your answer.

53. **A = 2    B = 24    C = 6    D = 12    E = 4**

$$(B \times A) \div E =$$

- A. A    B. B    C. C    D. D    E. E

54. **A = 26    B = 15    C = 4    D = 34    E = 12**

$$(B \times C) - A =$$

- A. A    B. B    C. C    D. D    E. E

55. **A = 3    B = 13    C = 8    D = 6    E = 12**

$$(C + A + B) \div 2 =$$

- A. A    B. B    C. C    D. D    E. E

56. **A = 2    B = 4    C = 6    D = 8    E = 0**

Divide the product of ABC by D then subtract C.

- A. A    B. B    C. C    D. D    E. E

57. **A = 7    B = 9    C = 5    D = 4    E = 11**

$$(A + D + B) \div C =$$

- A. A    B. B    C. C    D. D    E. E

58. **A = 3    B = 1    C = 10    D = 6    E = 5**

$$(B \times D \times E) \div A =$$

- A. A    B. B    C. C    D. D    E. E





59. A = 21    B = 3    C = 6    D = 4    E = 17

$$(C \times D) + B - C =$$

A. A

B. B

C. C

D. D

E. E

In each question, there are two pairs of words. You must select a word from the options below that will go equally well with both pairs.

60. (settle, trade)

(reduce, sink)

A. lesson

B. agree

C. contract

D. lower

E. stipulate

61. (rapid, short)

(keen, clever)

A. smart

B. quick

C. agile

D. cunning

E. swift

62. (point, direct)

(uncover, expose)

A. perform

B. display

C. lead

D. show

E. compass

63. (job, ability)

(purchase, contract)

A. buy

B. trade

C. deal

D. skill

E. employ

64. (divide, share)

(discrete, other)

A. slice

B. detach

C. distinct

D. sever

E. separate

65. (field, prairie)

(obvious, apparent)

A. simple

B. plain

C. express

D. meadow

E. modest

66. (winning, head)

(direct, show)

A. lead

B. race

C. commence

D. ahead

E. empower

67. (endure, persist)

(conclusion, ending)

A. final

B. last

C. closing

D. remain

E. unveil





There is an alphabet line to help you. Find the letters that will complete the sentence in the best way.

**A B C D E F G H I J K L M N O P Q R S T U V W X Y Z**

68. SR is to DE as CB is to ?

- A. MO      B. NN      C. NO      D. MN      E. ON

69. LM is to MA as WX is to ?

- A. YK      B. XL      C. XK      D. WM      E. XM

70. OP is to PI as ST is to ?

- A. UM      B. TM      C. SL      D. SN      E. UN

71. LK is to XG as CD is to ?

- A. NA      B. PZ      C. OA      D. PY      E. OZ

72. GF is to TU as PO is to?

- A. DE      B. BE      C. DD      D. CD      E. CC

73. LK is to TY as IH is to?

- A. RU      B. RW      C. QV      D. PV      E. QW

74. JK is to QY as EF is to?

- A. KS      B. KU      C. LT      D. LS      E. KT

Find **one** letter that will complete the word in front of the brackets and begin the word after the brackets. The **same letter** must fit into both sets of brackets.

75. HEA ( \_\_\_ ) ORE      CLA ( \_\_\_ ) INT

- A. P      B. T      C. D      D. L      E. M





76. FOR ( \_\_\_ ) UST

A. B                      B. D

CUR ( \_\_\_ ) ANGLE

C. L                      D. T                      E. M

77. SWA ( \_\_\_ ) OUT

A. L                      B. T

REA ( \_\_\_ ) ACK

C. P                      D. B                      E. R

78. SWA ( \_\_\_ ) UFF

A. T                      B. M

SLA ( \_\_\_ ) ARN

C. Y                      D. R                      E. B

79. SLA ( \_\_\_ ) INT

A. L                      B. T

HEA ( \_\_\_ ) END

C. P                      D. D                      E. M

80. HER ( \_\_\_ ) ASH

A. S                      B. W

CLA ( \_\_\_ ) ARE

C. B                      D. D                      E. M





# Mock Paper B – NVR

**Read the instructions carefully.**

1. This is a multiple-choice paper.
2. Circle the correct answer.
3. There are four sections in this paper. These sections are timed separately. You will be told when to start, when to stop a section and when to move on to the next section. You will have **10 minutes to complete each section.**
4. The test lasts for **40 minutes in total.**
5. There are **80 questions in total.**
6. You may find some of the questions difficult. If you cannot do a question, do not waste time on it, but go on to the next questions. If you are not sure of an answer, choose the one you think is best.
7. Work as quickly and as carefully as you can.
8. Make sure you can see a clock.
9. Allocate enough time to check your answers at the end.







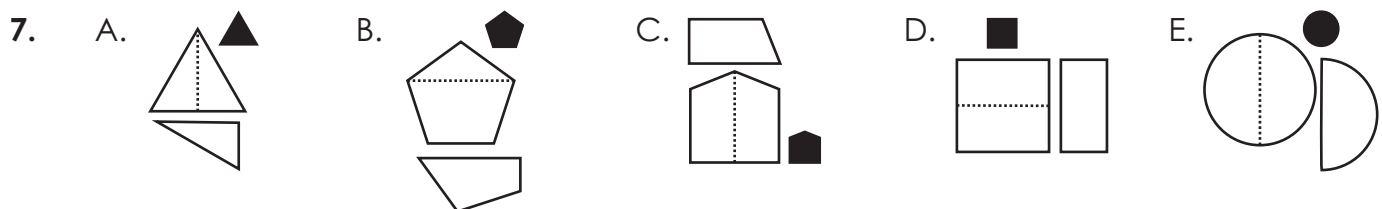
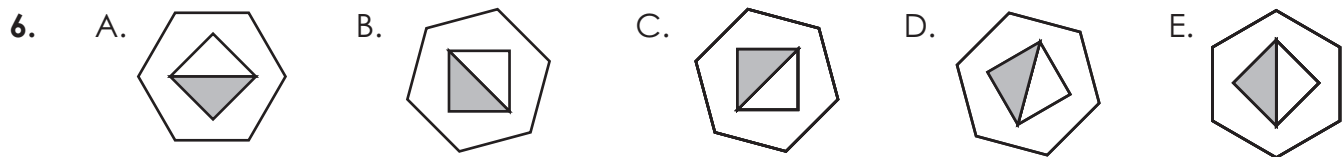
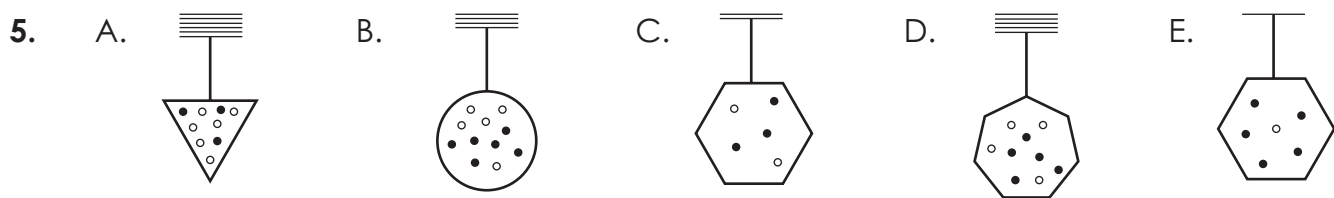
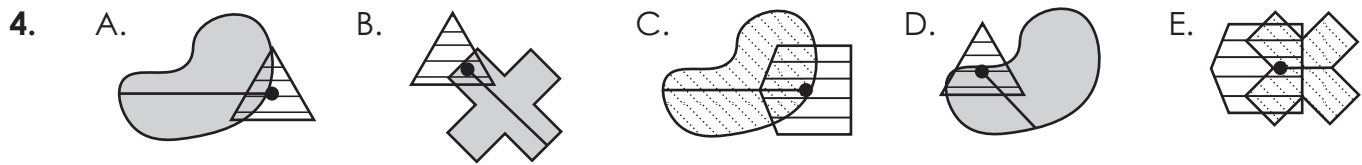
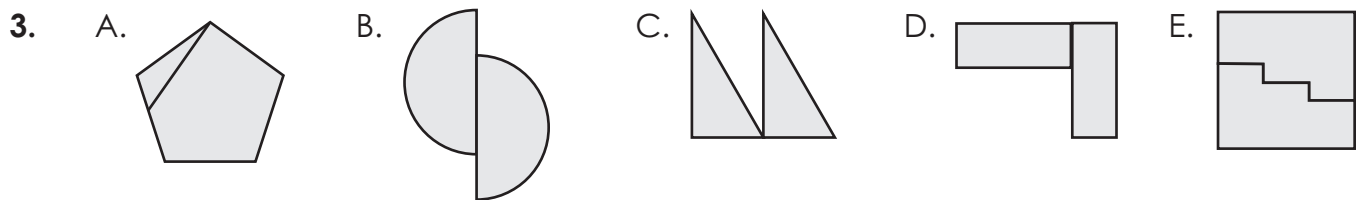
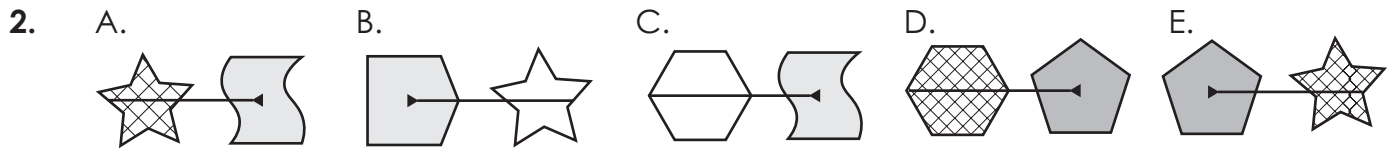
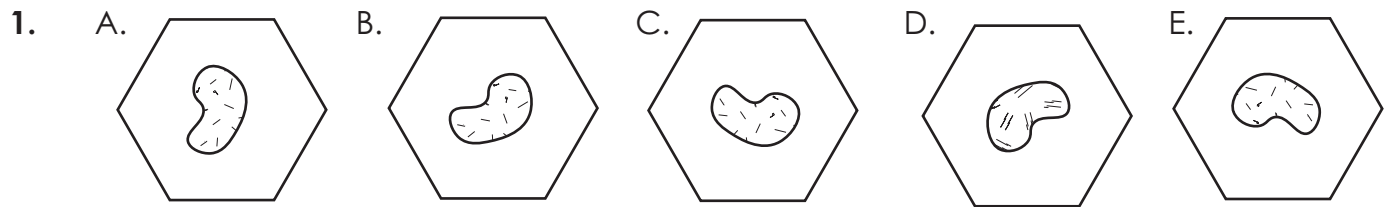





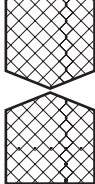
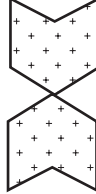

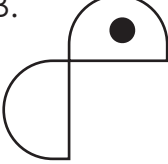







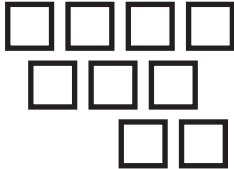

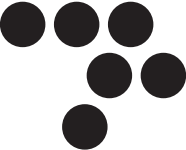

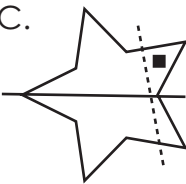
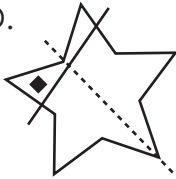

**Section 1 – You have 10 minutes to answer this section**

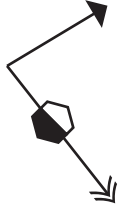
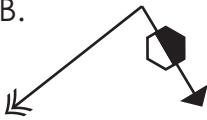
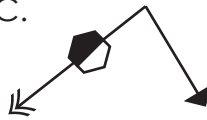
In the questions below, choose the figure that is the odd one out.

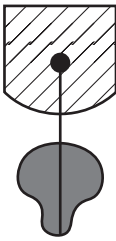
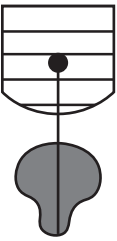
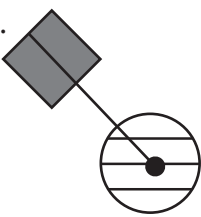
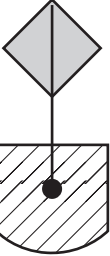
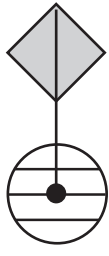
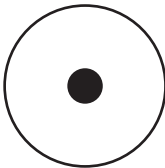
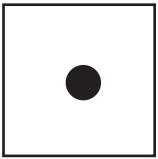

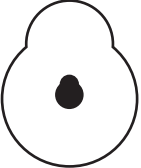

8. A.  B.  C.  D.  E. 
9. A.  B.  C.  D.  E. 
10. A.  B.  C.  D.  E. 
11. A.  B.  C.  D.  E. 
12. A.  B.  C.  D.  E. 
13. A.  B.  C.  D.  E. 
14. A.  B.  C.  D.  E. 
15. A.  B.  C.  D.  E. 



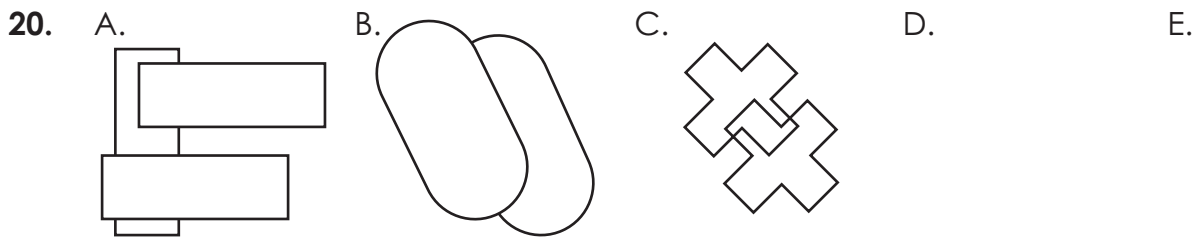
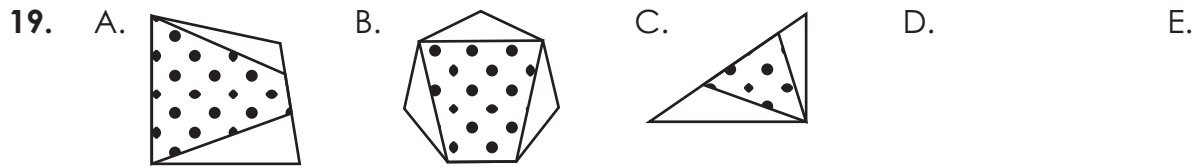
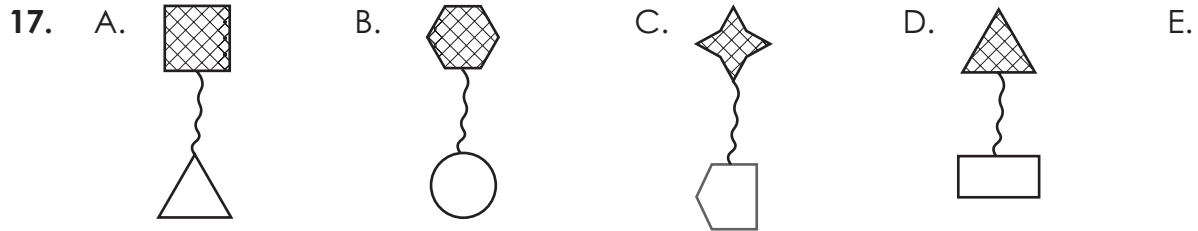

End of Section 1  
Turn over for Section 2





**Section 2 – You have 10 minutes to complete this section**

In the questions below, choose the missing code.

21.

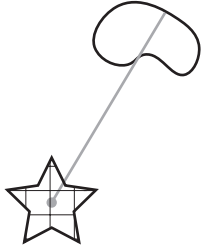

**SW**



**TX**



**UX**

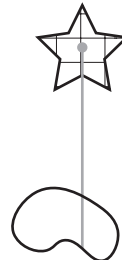

**SX**

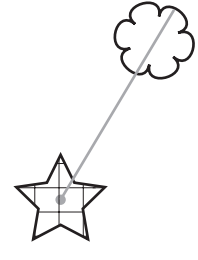

**?**

A. TW

B. SW

C. UW

D. UX

E. TX

22.

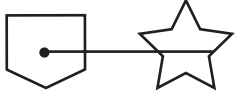

**PH**

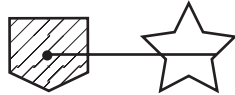

**PI**



**PJ**

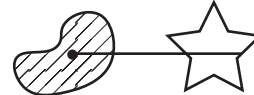

**QI**

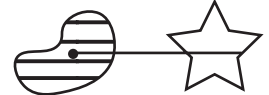

**?**

A. PJ

B. QJ

C. QI

D. PI

E. QH

23.

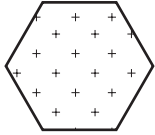

**LF**

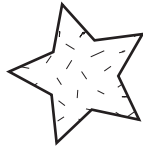

**JW**

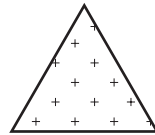

**LD**



**RC**

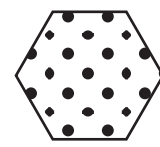

**?**

A. RF

B. LC

C. JD

D. LF

E. RD

24.

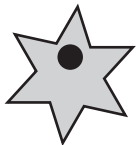

**VS**



**PXA**



**VQJ**



**KSB**

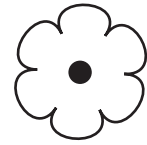

**?**

A. KXA

B. PSB

C. VSA

D. PXJ

E. VXA





25.



**YCV**

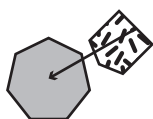

**YFH**



**NCH**



**NBV**



**?**

A. NCV

B. YFV

C. YCH

D. NCV

E. YCV

26.



**PG**

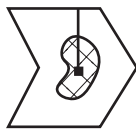

**QG**



**PK**



**PL**



**?**

A. PK

B. QG

C. QK

D. QL

E. PG

27.



**MUHP**



**NVIP**

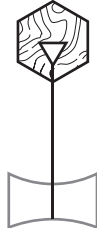

**OVHQ**

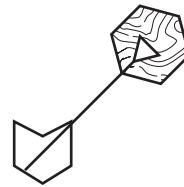

**?**

A. NUHP

B. MVHP

C. OUIP

D. NUHQ

E. MVHQ

28.

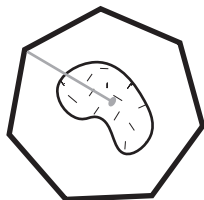

**NXR**

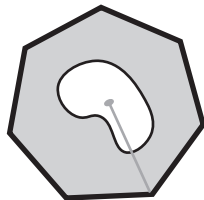

**OYS**

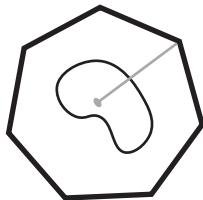

**NYT**

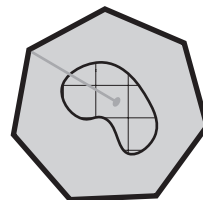

**OZR**

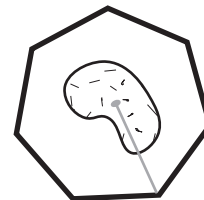

**?**

A. OYS

B. OXS

C. NXS

D. NYR

E. NZT

29.

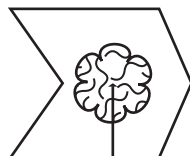

**GT**

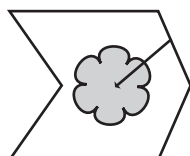

**EU**

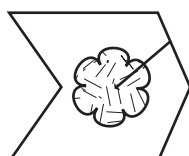

**FU**

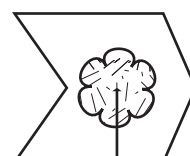

**?**

A. ET

B. GU

C. GT

D. FT

E. FU





30.

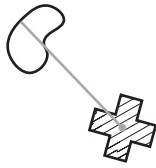

TI

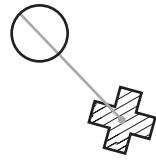

MI

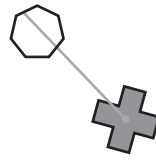

NJ

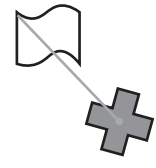

TJ

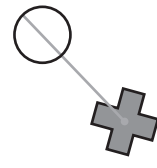

?

A. NI

B. TI

C. MJ

D. MI

E. TJ

31.

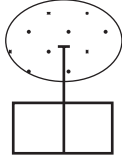

BI

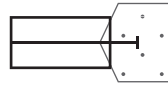

CJ

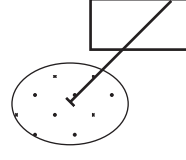

BK

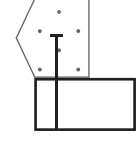

?

A. CI

B. JB

C. CK

D. CJ

E. BK

32.

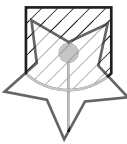

OD

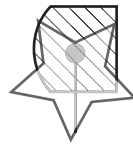

OE

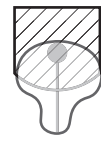

PD

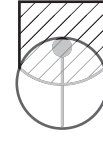

QD

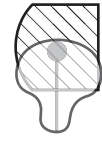

?

A. PD

B. QE

C. DQ

D. PE

E. EP

33.



EWP

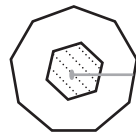

EXQ

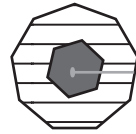

FYQ

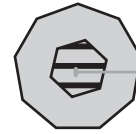

GWQ

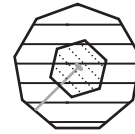

?

A. EXP

B. FXP

C. FWP

D. GWP

E. GXQ

34.

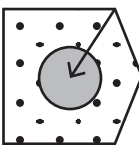

SCH



XBO

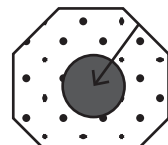

VBH



SCN

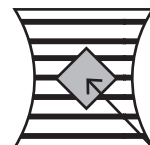

?

A. VXO

B. SCO

C. XBN

D. XCN

E. VBN





35.

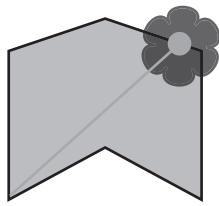

RAK

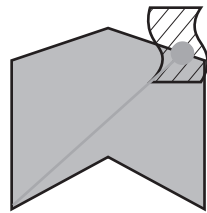

RBL

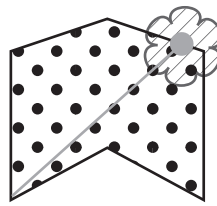

SAL

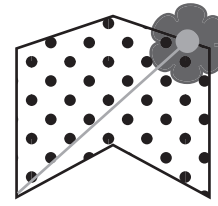

?

A. SAB

B. RAL

C. SAK

D. SAL

E. RBK

36.

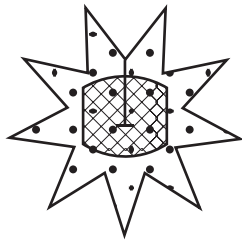

THX

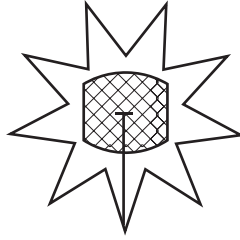

TIY

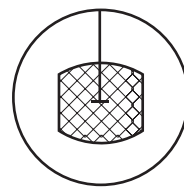

UIX

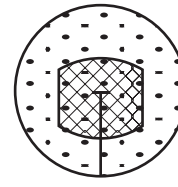

?

A. TIX

B. UHX

C. TXH

D. TXY

E. UHY

37.



SJPG

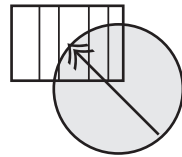

SKQH



TJRH

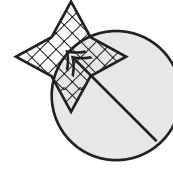

?

A. SJPH

B. TJQH

C. SKPH

D. SJPG

E. TJPH

38.

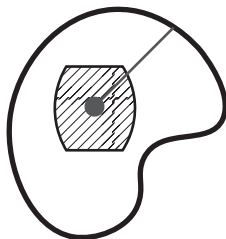

OAHU



OBIV

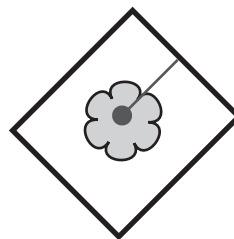

PBJU

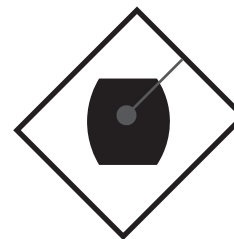

?

A. OAJU

B. PAIU

C. OBIV

D. PAJV

E. PBIU







39.

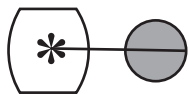

**OAEX**



**OBFY**



**PBGX**



**?**

A. OAFX

B. OBGY

C. OAGY

D. PAGX

E. PBGY

40.

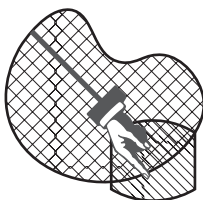

**NQCW**

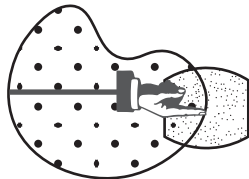

**OQDX**

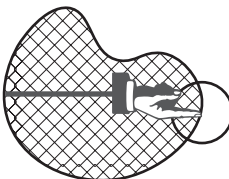

**NREX**

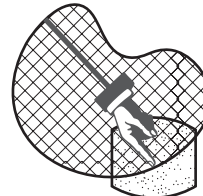

**?**

A. OQCW

B. NQEW

C. NQDW

D. OQDX

E. NRDW

**End of Section 2  
Turn over for Section 3**





**Section 3 – You have 10 minutes to complete this section**

In the questions below, choose the figure that completes the series.

41.

A.

B.

C.

D.

E.

42.

43.





44.

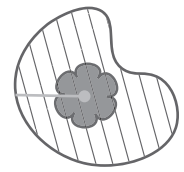
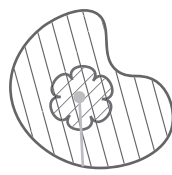
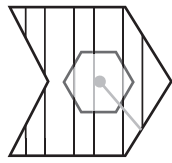
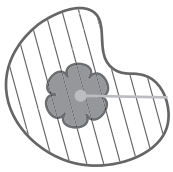

A.

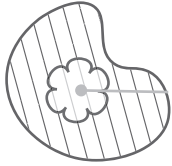

B.

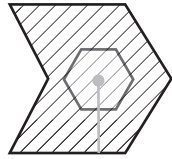

C.



D.



E.

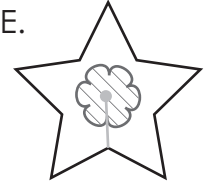

45.

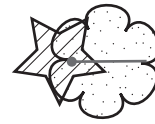
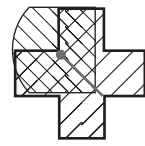
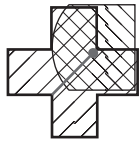

A.



B.

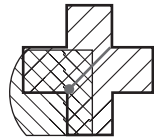

C.

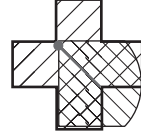

D.



E.

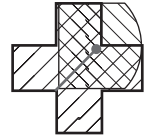

46.

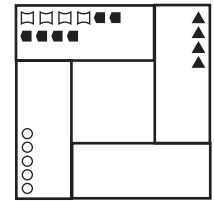
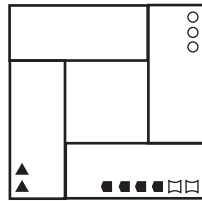
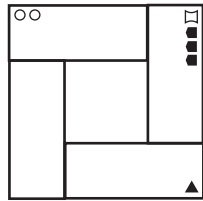
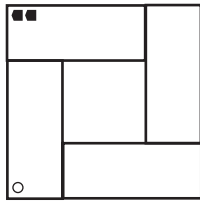

A.

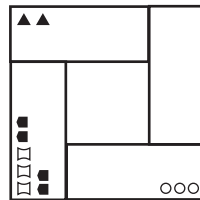

B.

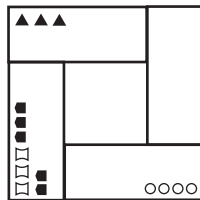

C.

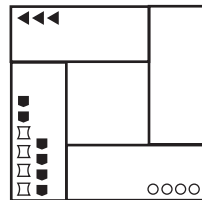

D.

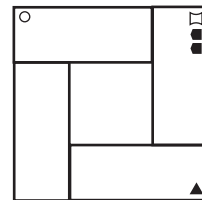

E.

47.

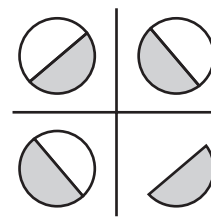
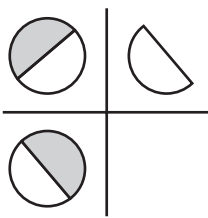
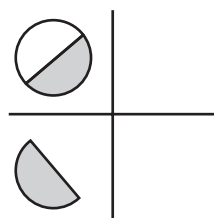
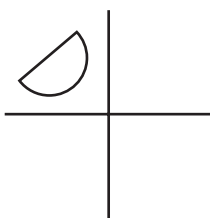

A.

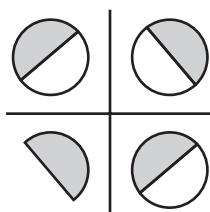

B.

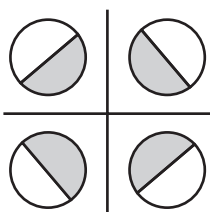

C.

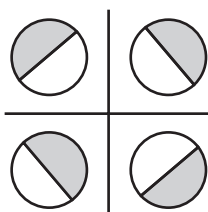

D.

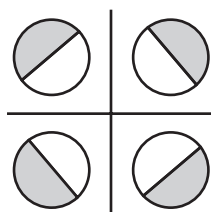

E.

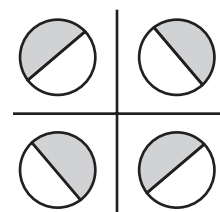



48.



A.



B.



C.



D.



E.



49.

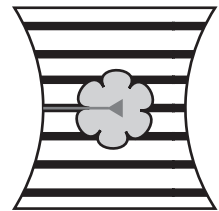
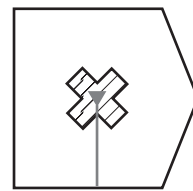
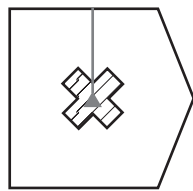
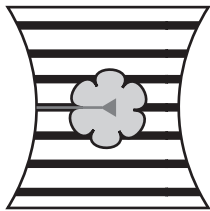

A.

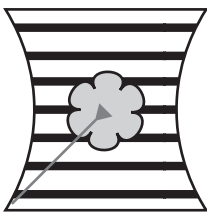

B.



C.

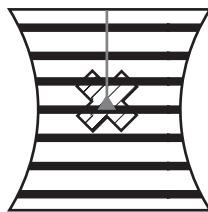

D.

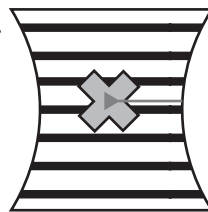

E.

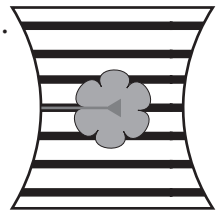

50.

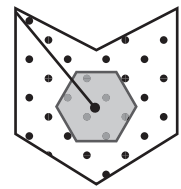
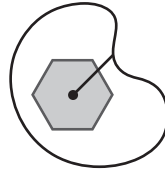
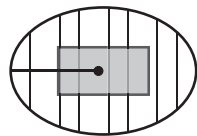
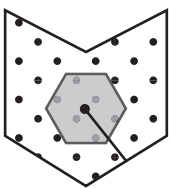

A.

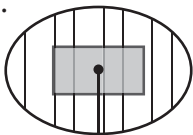

B.

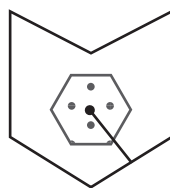

C.

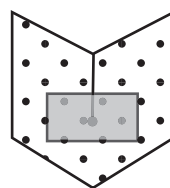

D.

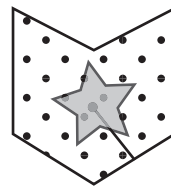

E.

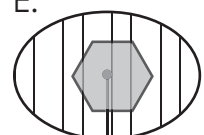

51.

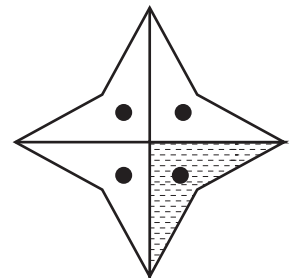
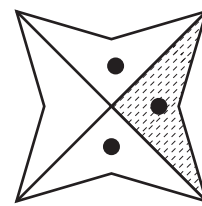
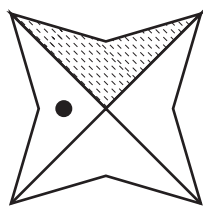
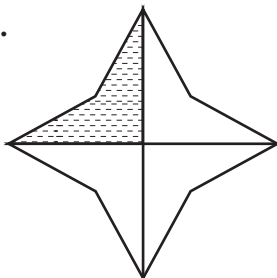

A.

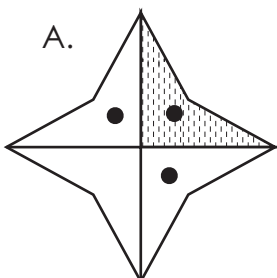

B.

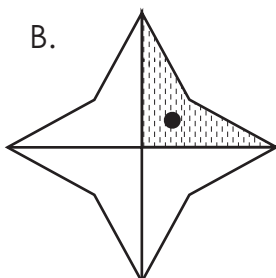

C.

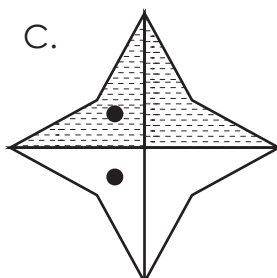

D.

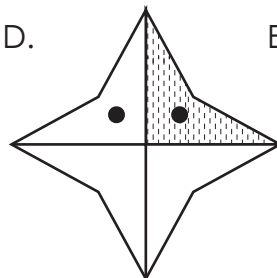

E.

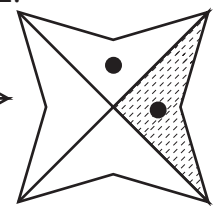



52.

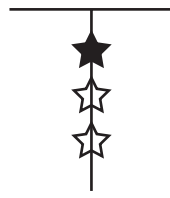

A.

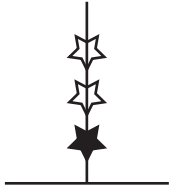

B.



C.

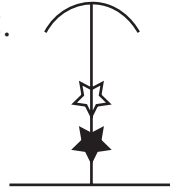

D.



E.

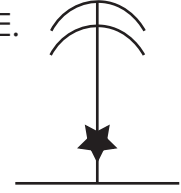

53.

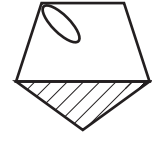
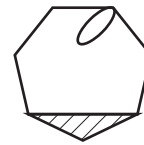
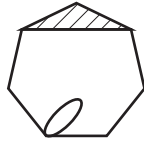
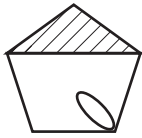

A.

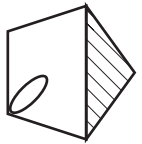

B.

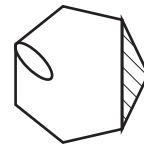

C.

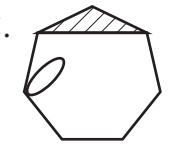

D.

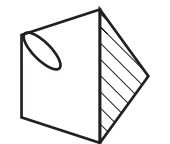

E.

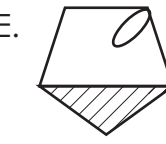

54.

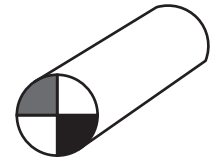
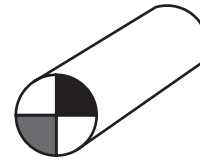
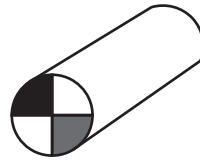
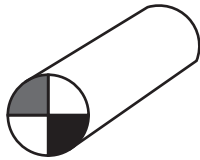

A.

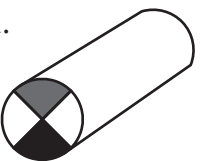

B.

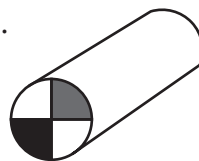

C.

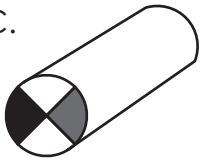

D.

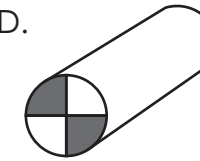

E.



55.

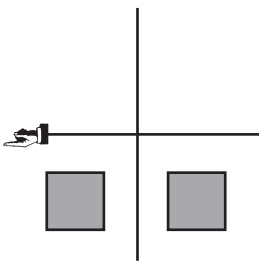
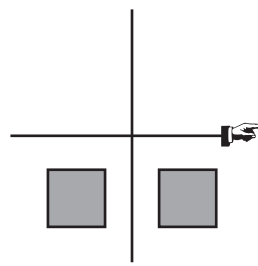
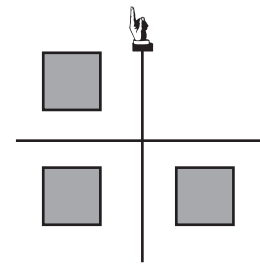
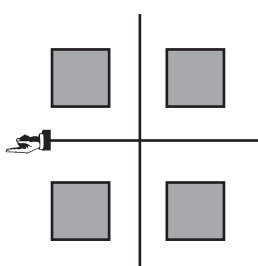

A.

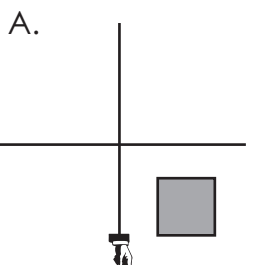

B.

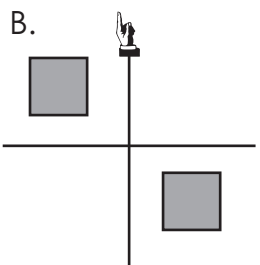

C.

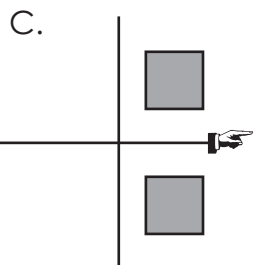

D.

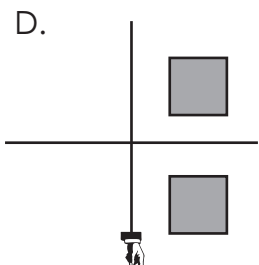

E.

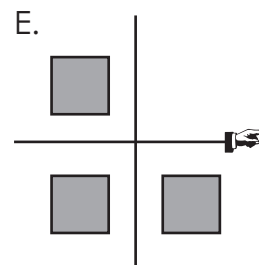



56.

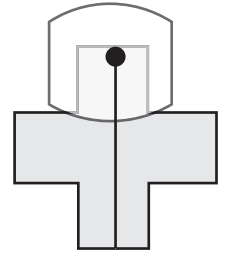
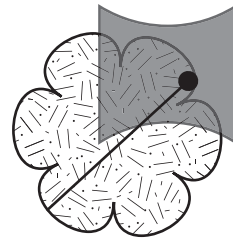
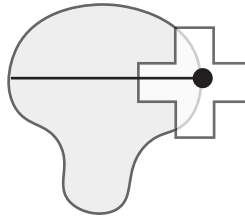
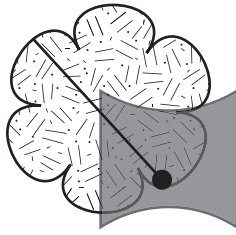

\_\_\_\_\_

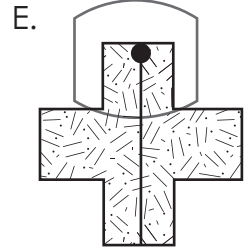
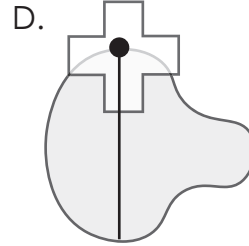
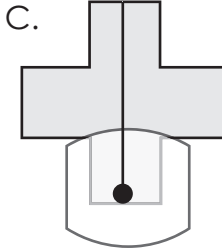
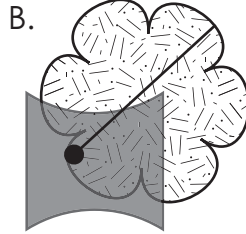
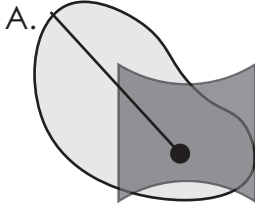

57.

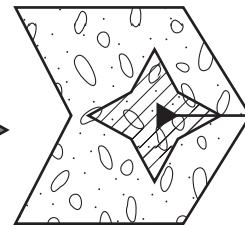
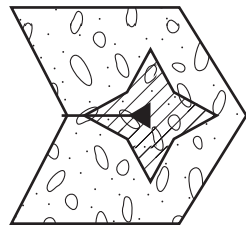
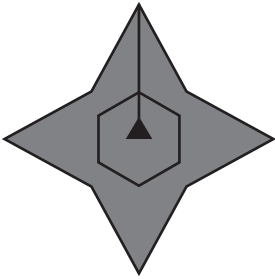

\_\_\_\_\_

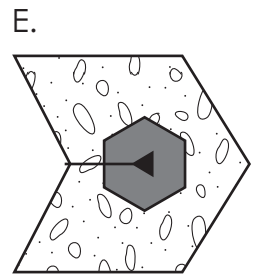
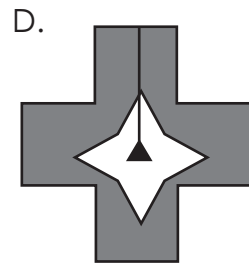
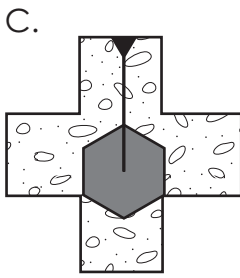
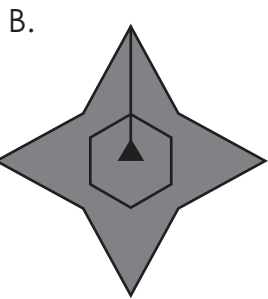
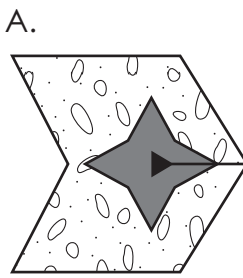

58.

\_\_\_\_\_

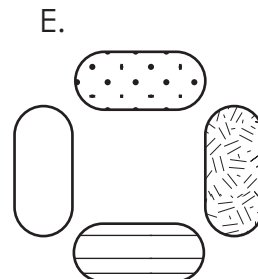
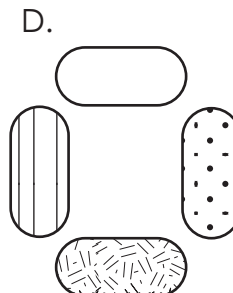
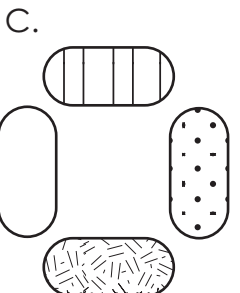
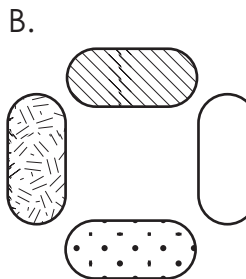
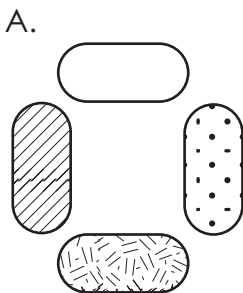
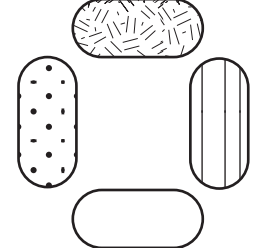
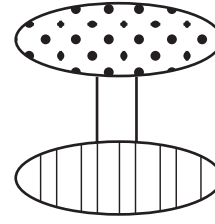
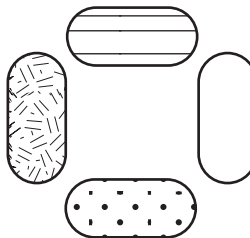
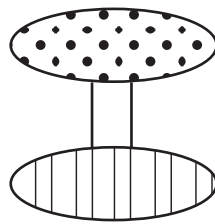



59.

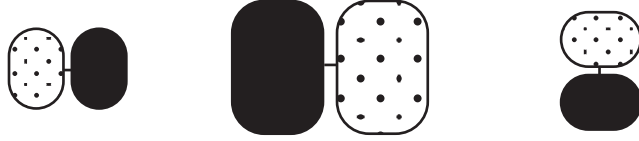

\_\_\_\_\_

- A.
- B.
- C.
- D.
- E. \_\_\_\_\_

60.

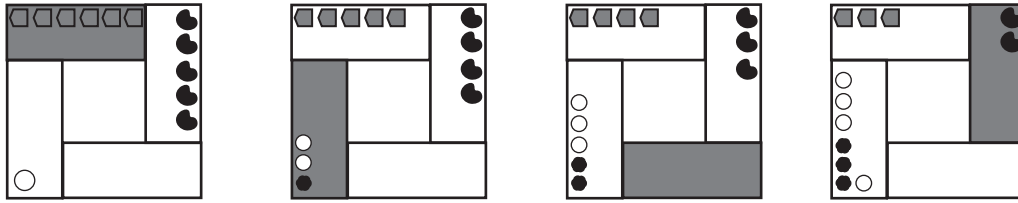

\_\_\_\_\_

- A.
- B.
- C.
- D.
- E. \_\_\_\_\_

**End of Section 3  
Turn over for Section 4**



**Section 4 – You have 10 minutes to complete this section**

In the questions below, choose the answer option that is most similar to the figures in the question.

61.

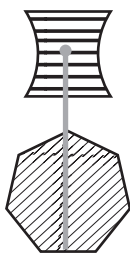
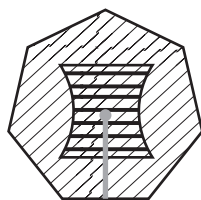

A.

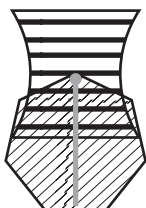

B.

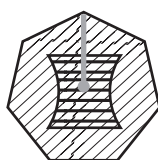

C.

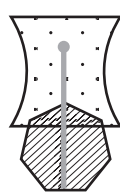

D.

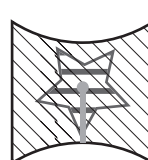

E.

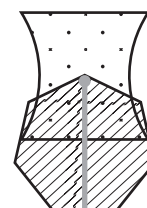

62.



A.

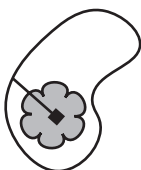

B.

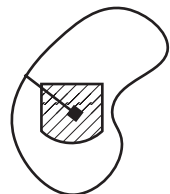

C.

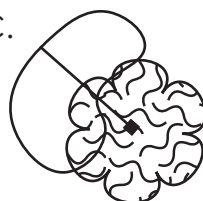

D.



E.



63.

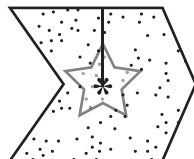
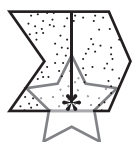

A.



B.



C.

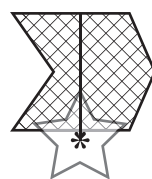

D.



E.



64.

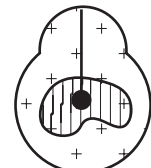

A.

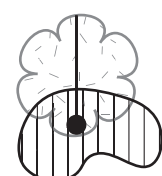

B.

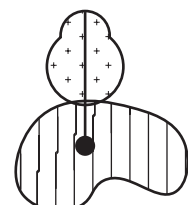

C.

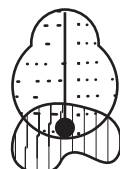

D.



E.

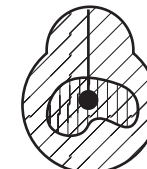





65.



A.

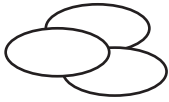

B.



C.

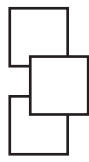

D.



E.



66.

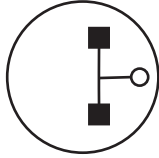
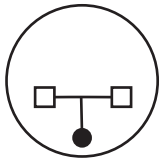

A.

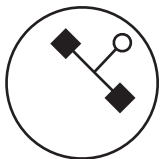

B.

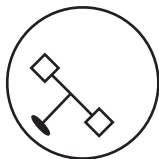

C.

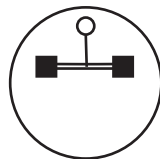

D.

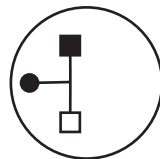

E.

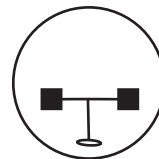

67.

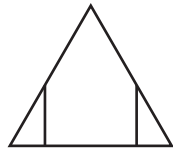
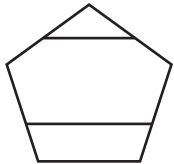

A.

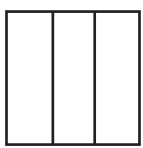

B.



C.

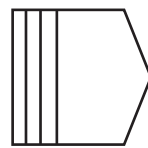

D.

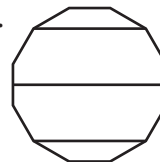

E.

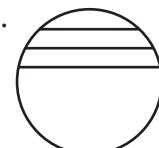

68.

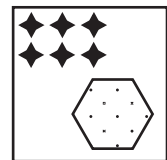

A.

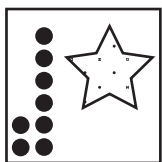

B.

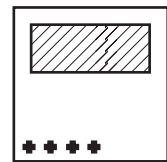

C.

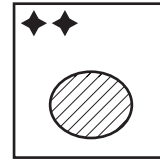

D.

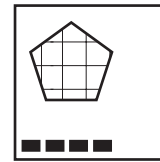

E.

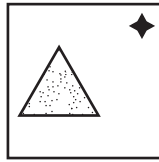



69.

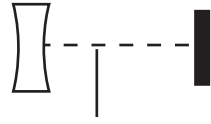

A.



B.



C.



D.



E.



70.

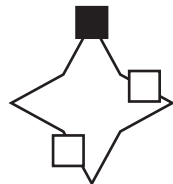
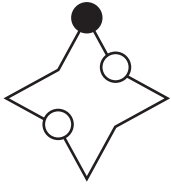

A.

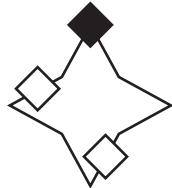

B.

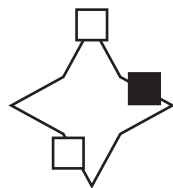

C.

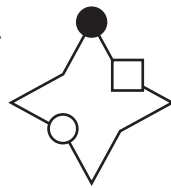

D.

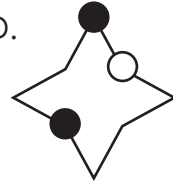

E.

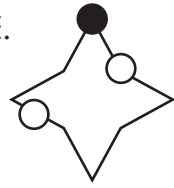

71.

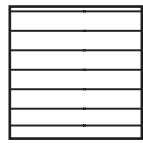
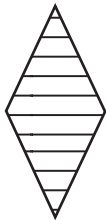

A.

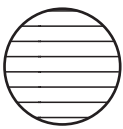

B.

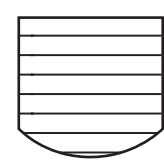

C.



D.

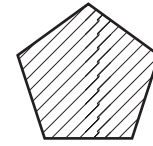

E.

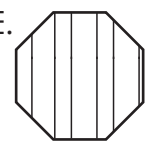

72.

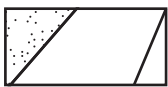

A.



B.

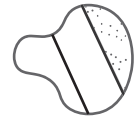

C.

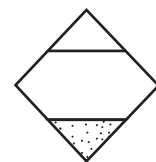

D.

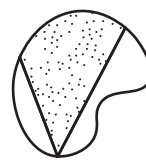

E.

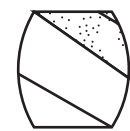

73.



A.

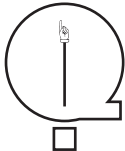

B.

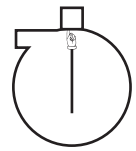

C.

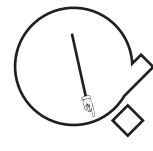

D.

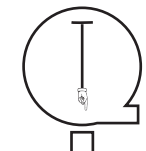

E.





74.



A.



B.



C.



D.



E.



75.

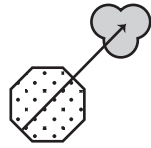
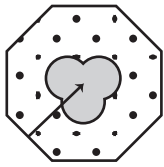

A.

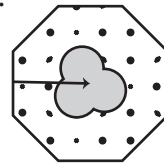

B.

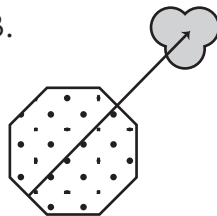

C.

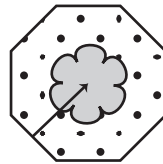

D.

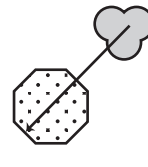

E.

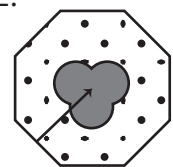

76.

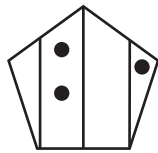
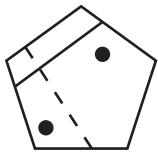

A.

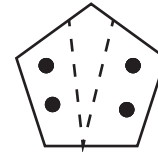

B.

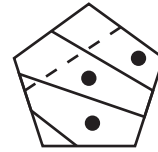

C.

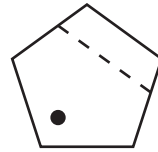

D.

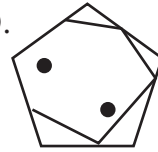

E.

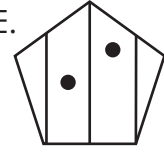

77.

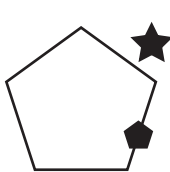
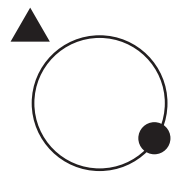

A.

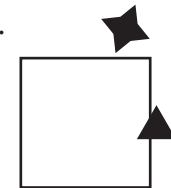

B.

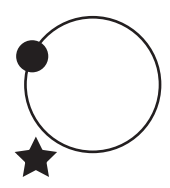

C.



D.



E.





78.



A.



B.

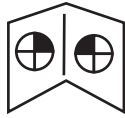

C.



D.



E.



79.



A.



B.



C.



D.



E.



80.

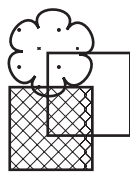
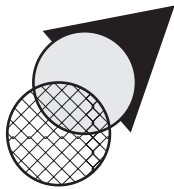

A.



B.

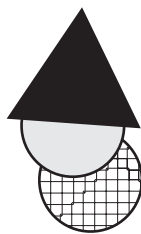

C.

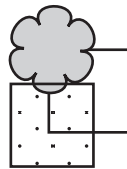

D.



E.

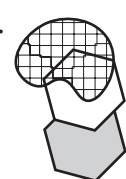

End of Section 4





# SELF REFLECTION

Take some time to reflect on your review test experience. Although they may sometimes feel stressful, exams can also be valuable learning opportunities.

## Your preparation

How confident did you feel going into the exam?



Did you prepare / revise for the test in any way?

---

---

## Your performance

Did you understand and follow the instructions given for the exam?

<input type="checkbox"/>	<input type="checkbox"/>
yes	no

Did you have enough time to answer all the questions in the exam?

<input type="checkbox"/>	<input type="checkbox"/>
yes	no

Which topics were you most confident answering?

---

---

Which topics were you least confident answering?

---

---

What emotions did you feel during the exam?

---

---

## What might you do differently next time?

In preparation for your next exam, write down one thing you will keep doing and one thing you will change for next time.

Keep	Change





**Explore**  
LEARNING



1ELLPS10299