

Suitable for the following Rinnai INFINITY models:

- A16 (REU-A1620WG-ZK)
- A20 (REU-A2024WG-ZK)
- A24 (REU-A2426WG-ZK)
- A26 (REU-A2626WG-ZK)
- EF26 (REU-E2626W-ZK)

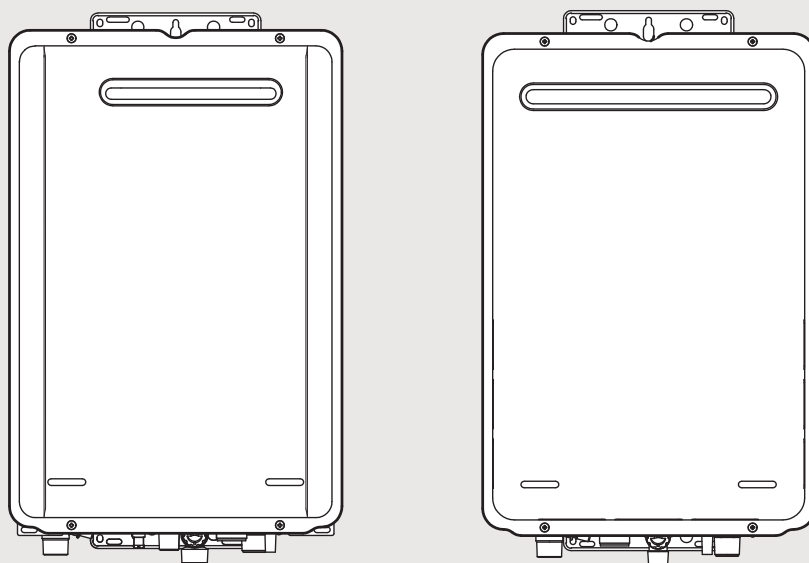

## **INFINITY EF26 and A-Series continuous flow water heaters**

### Installation guide

**Rinnai**

---

# Important

---

This appliance must be installed in accordance with:

- Manufacturer's installation instructions
- Current AS/NZS 3000, AS/NZS 3500, AS/NZS 5601.1 and G12/AS1

For use with Natural Gas or Universal LPG as indicated on the appliance.

Not suitable as a spa or swimming pool heater.

Not suitable for hydronic applications.

Not suitable for commercial or solar applications.

Not suitable for locations greater than 1000 m above sea level.

Appliance must be installed, commissioned and serviced by an authorised person, being in New Zealand a licensed gasfitter.

## **Warning**

Improper installation, adjustment, alteration, service and maintenance can cause property damage, personal injury or loss of life.

For more information about buying, using, and servicing of Rinnai appliances call: 0800 RINNAI (0800 746 624).

Rinnai New Zealand Limited  
105 Pavilion Drive, Mangere, Auckland  
PO Box 53177, Auckland Airport, Auckland 2150

Phone: (09) 257-3800  
Fax: (09) 257-3899  
Email: [info@rinnai.co.nz](mailto:info@rinnai.co.nz)  
Web: [rinnai.co.nz](http://rinnai.co.nz)  
[youtube.com/rinnainz](https://www.youtube.com/rinnainz)  
[facebook.com/rinnainz](https://www.facebook.com/rinnainz)

---

# Contents

---

Specification .....	4
Connections and fittings .....	5
Dimensions.....	6
Appliance location .....	8
General installation information .....	9
Water delivery temperature .....	10
Controller installation.....	11
EF26 condensate neutraliser tank and drain.....	12
Commissioning .....	14
Sideways flue diverter dip switch changes .....	15
PCB interface and functions .....	16
A-Series controller communication cables .....	18
EF26 controller communication cables.....	19

## Before installation

Unpack the appliance and check for damage. DO NOT install any damaged items.

Check all components and that the correct gas type has been supplied.

Get an overview of the steps required before starting the installation. Failure to follow these instructions could cause a malfunction of the appliance. This could result in serious injury and property damage.

These instructions apply only to the continuous flow water heater models listed on the front of this guide.

# Specification

Designed and made in Japan, the Rinnai INFINITY EF26 and A-Series are continuous flow gas hot water heaters with inbuilt frost protection. The EF26 is a condensing model. They have electronic ignition and require electricity to operate. They are factory set to 50 °C<sup>1</sup>.

## Scope of use

Suitable for **residential** applications only. They are designed to be externally mounted on an outside wall and located as close as practicable to the most frequently used hot water outlet(s), to reduce the delay for hot water delivery.

They are not suitable as a spa or swimming pool heater, and for hydronic heating. They are also not suitable as a gas boost for solar installations as the temperature cannot be set high enough.

Hard or acidic water will need to be treated to use this product.

## Specification summary

	<b>A16</b> REU-A1620WG-ZK	<b>A20</b> REU-A2024WG-ZK	<b>A24</b> REU-A2426WG-ZK	<b>A26</b> REU-A2626WG-ZK	<b>EF26</b> REU-E2626W-ZK
Thermal efficiency	80.5%	80.5%	81%	80.5%	91.5%
Hot water capacity	1.5-20 L/min	1.5-24 L/min	1.5-26 L/min	1.5-26 L/min	1.5-26 L/min
Hot water capacity at a 25° rise	16 L/min 960 L/h	20 L/min 1200 L/h	24 L/min 1440 L/h	26 L/min 1560 L/h	26 L/min 1560 L/h
Input	16.3-124 MJ/h	19.9-156 MJ/h	16.3-184 MJ/h	16.3-199 MJ/h	16.3-175 MJ/h
Output	27.8 kW	34.9 kW	42.0 kW	44.5 kW	44.5 kW
Weight	13 kg	14 kg	15 kg	15 kg	18 kg
Water, nominal operating pressure	120-1000 kPa	160-1000 kPa	200-1000 kPa	200-1000 kPa	220-1000 kPa
Ingress protection	IPX4	IPX4	IPX4	IPX4	IPX5
Power consumption:					
- Normal	47 W	58 W	56 W	65 W	63 W
- Standby	2 W	2 W	2 W	2 W	2 W
- Frost protection	68 W	68 W	68 W	68 W	92 W

## Safety devices

- Flame failure
- Boil-dry protection
- Overheat protection (OHS)
- Fusible link
- Pressure relief valve
- Combustion fan rpm check

## Line pressures

- NG 1.13-3.0 kPa
- LPG 2.75-3.0 kPa

Standing and flowing pressure must be less than 3.0 kPa.

<sup>1</sup> Maximum set temperature is 65 °C.

# Connections and fittings

## A-Series

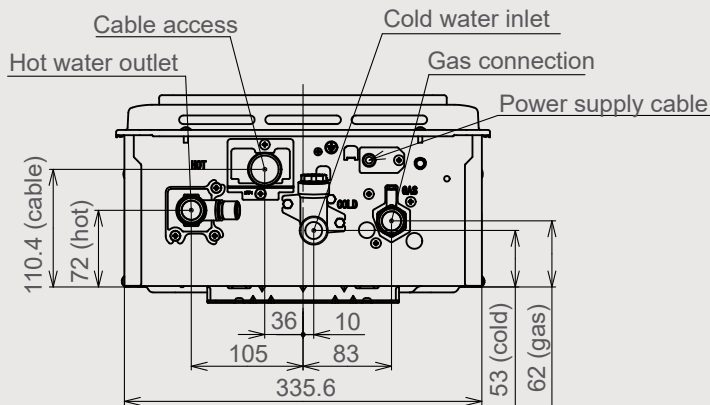

- From bottom of unit:
- Hot 41 mm (A16 39 mm)
  - Cable 29 mm
  - Gas 40 mm
  - Cold 50 mm

## EF26

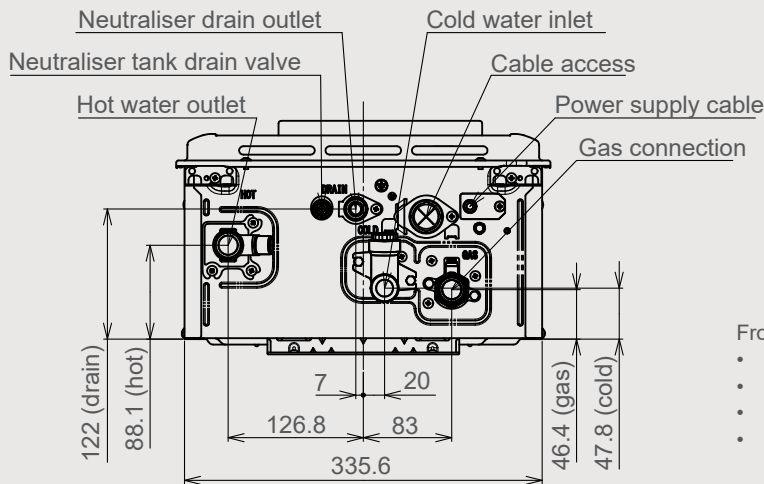

- From bottom of unit:
- Hot 41 mm
  - Cable 26 mm
  - Gas 38 mm
  - Cold 50 mm

		Hot	Cold	Gas	Condensate
A16 external	REU-A1620WG-ZK	R $\frac{1}{2}$ (15 mm)	R $\frac{1}{2}$ (15 mm)	R $\frac{3}{4}$ (20 mm)	N/A
A20 external	REU-A2024WG-ZK	R $\frac{3}{4}$ (20 mm)	R $\frac{3}{4}$ (20 mm)	R $\frac{3}{4}$ (20 mm)	N/A
A24 external	REU-A2426WG-ZK	R $\frac{3}{4}$ (20 mm)	R $\frac{3}{4}$ (20 mm)	R $\frac{3}{4}$ (20 mm)	N/A
A26 external	REU-A2626WG-ZK	R $\frac{3}{4}$ (20 mm)	R $\frac{3}{4}$ (20 mm)	R $\frac{3}{4}$ (20 mm)	N/A
EF26 external	REU-E2626W-ZK	R $\frac{3}{4}$ (20 mm)	R $\frac{3}{4}$ (20 mm)	R $\frac{3}{4}$ (20 mm)	R $\frac{1}{2}$ (15 mm)

### Service connection points

An approved full flow isolation valve and disconnection union **MUST BE** fitted to the cold water inlet. A non-return valve is not required unless stipulated by local regulations.

Isolation valves **MUST NOT** be fitted directly the appliance.

It may be necessary to fit a temperature limiting device for delivery to areas used primarily for the purposes of personal hygiene, refer page on 'Water delivery temperature' for more information.

Purge gas and cold water supply lines to remove air and swarf before final connection. Swarf in the gas or water supplies may cause damage, a common problem, which is not covered by warranty.

# Dimensions (mm)

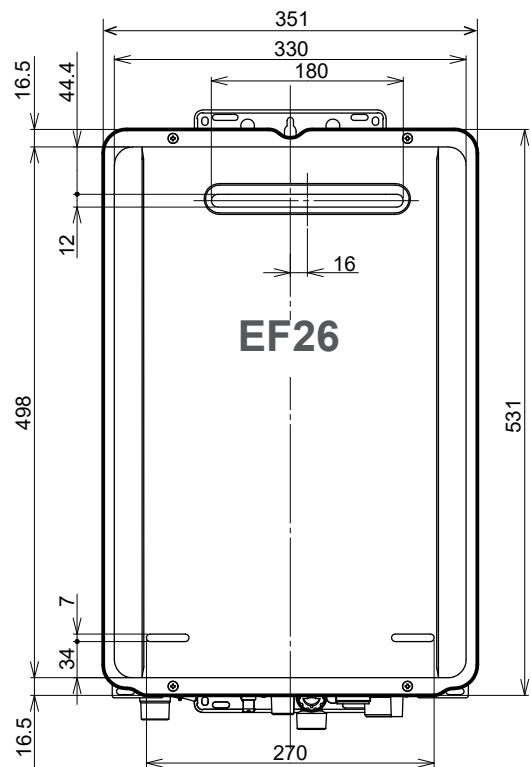
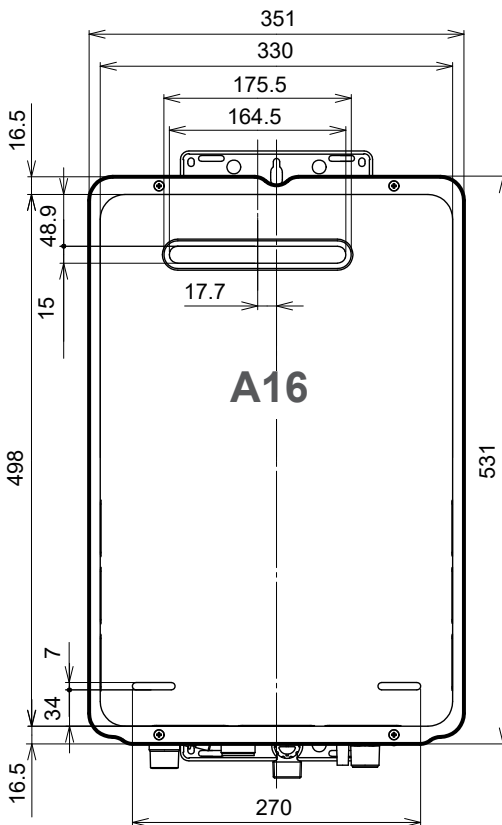
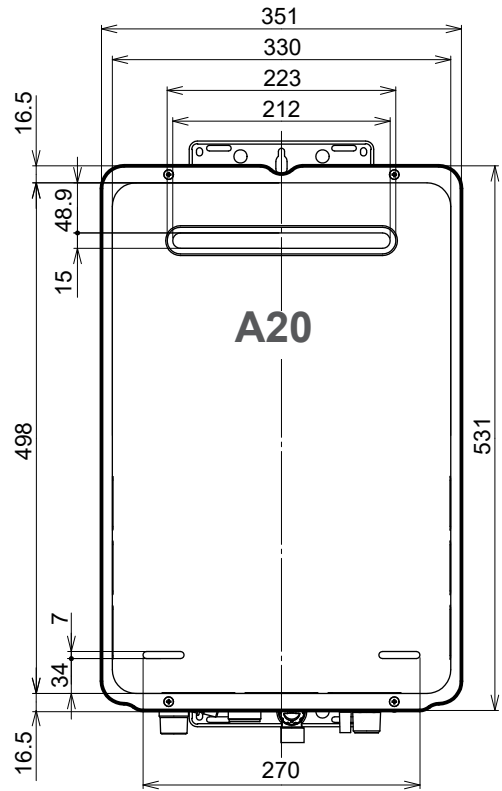
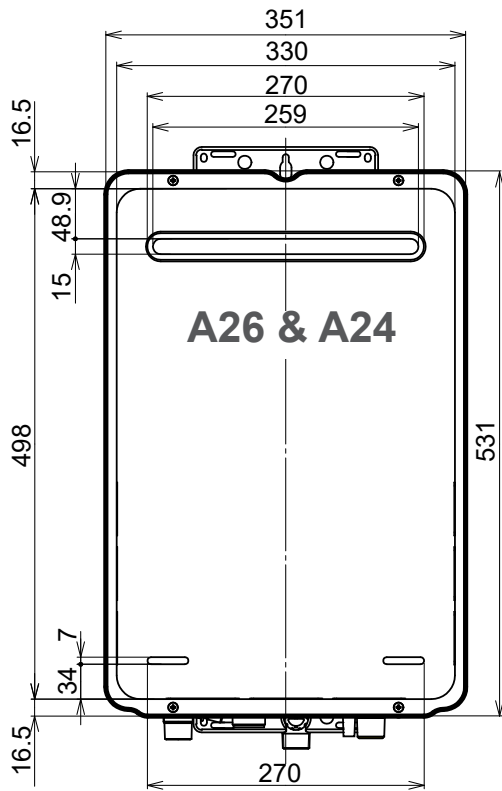

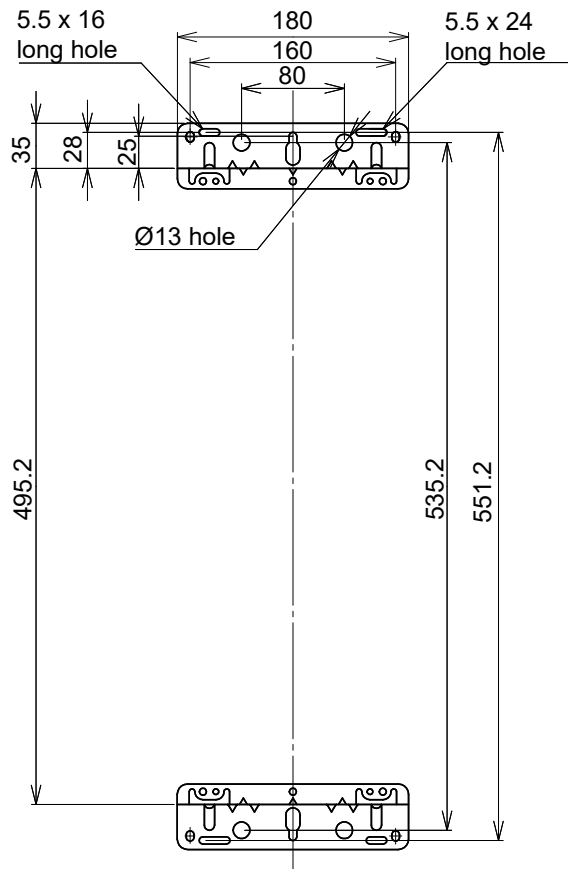
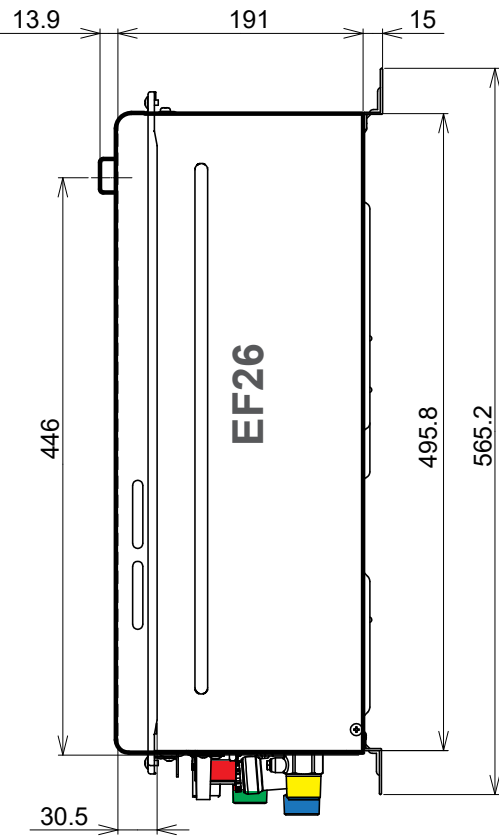
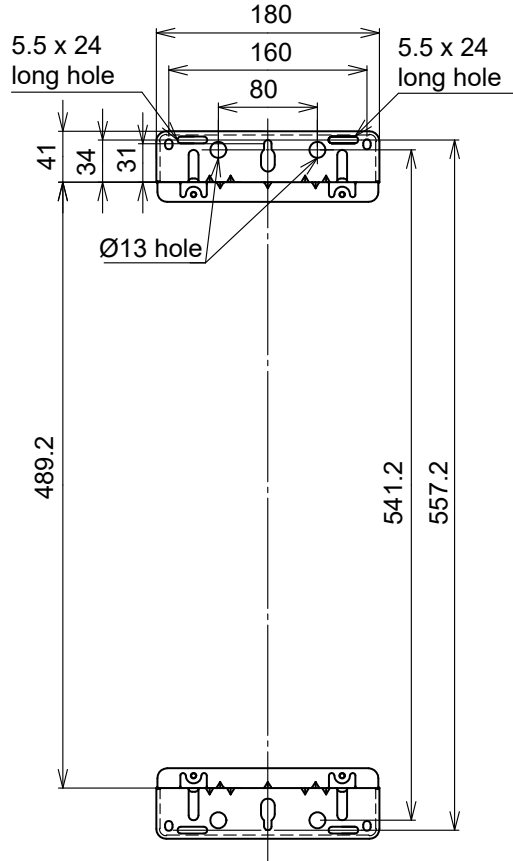
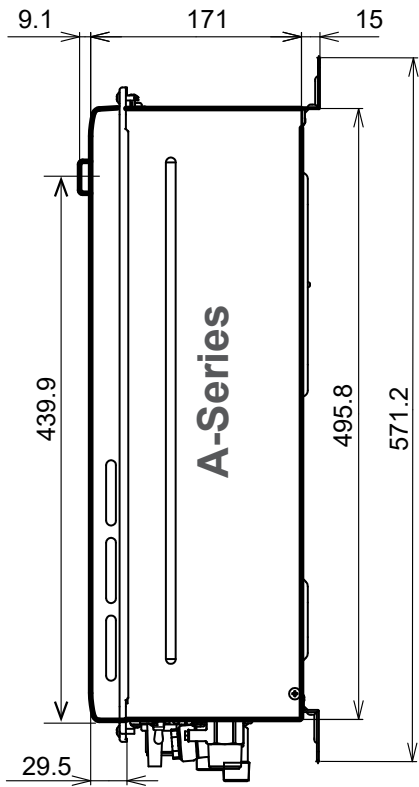

# Appliance location

This appliance is designed for outdoor installations only. It **MUST BE** located above ground in open air with natural ventilation, without stagnant areas, where gas leakage and products of combustion can be rapidly dispersed by wind and natural convection.

This appliance **MUST BE** placed as close as possible to the most frequently used hot water outlet(s) to minimise the delay for hot water delivery<sup>1</sup>. For installations where the distance between the water heater and outlets is considerable, a flow and return system can be used to minimise the waiting time for hot water delivery. Alternatively multiple appliances can be strategically placed to serve outlets with minimal delay.

An AC 230 V, 10 A earthed power point must be provided adjacent<sup>2</sup> to the appliance. This power point must be weatherproof. It must be clear of the gas and water connections to the appliance and also the flue exhaust and water pressure relief valve. The power cord of the appliance is 1.5 m long.

All appliances **MUST BE** installed to ensure access can be gained without hazard or undue difficulty for maintenance and servicing. Sufficient clearances shall allow access and removal of all serviceable components. Appliances should not be mounted more than 2.5 m above the ground or floor level unless the customer can arrange permanent and safe access, or can provide another means of safe access.

The appliance **MUST BE** mounted on a vertical structure with the water and gas connections on the underside pointing downwards.

Location of the flue terminal **MUST BE** in accordance with Section 6 and Figure 6.2 of AS/NZ 5601.

The E26 / A-Series are suitable for installations up to 1000 m above sea level. They are not suitable for alpine areas.

## Operating noise

Some people are susceptible to low level noise. INFINITY units operate at around 50-54 dB(A). This needs to be considered if locating the appliance near a bedroom.

## Horizontal obstructions

AS/NZS 5601 states a minimum horizontal clearance of 500 mm between a building structure and obstruction facing the terminal. At 500 mm the obstruction needs to be the full height of the unit, as shown below, and not a partial obstruction. A partial obstruction of less than 1 m could result in wind pushing the flue gases back into the flue terminal.

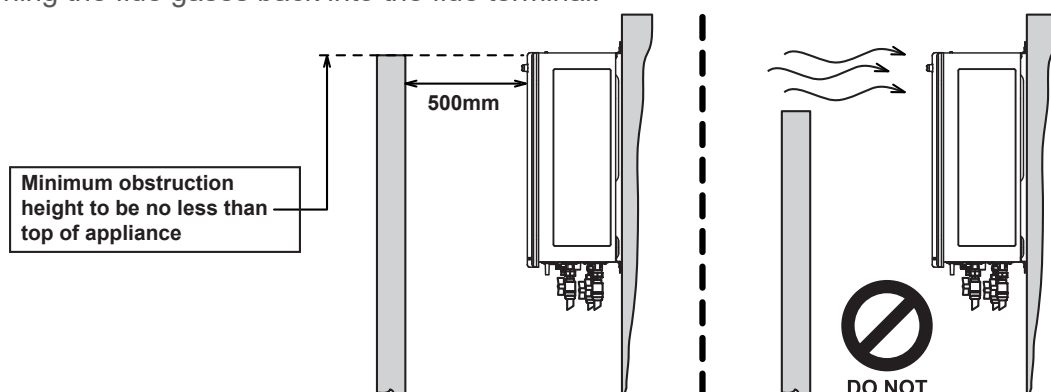

There **MUST** be **NO** partial obstructions to the appliance front cover or any other part of the appliance casing. This will avoid the appliance from failing to operate under windy conditions.

<sup>1</sup> Rinnai recommend a maximum pipe run of 10 m.

<sup>2</sup> Power point can be within the pipe cover if a pipe cover is installed—must comply with AS/NZS Wiring rules

# General installation information

## Securing the Rinnai INFINITY

The wall structure on which units are mounted **MUST BE** capable of supporting the weight of the appliance and associated pipe work.

Ensure that suitable fixing screws or bolts are used to secure the unit to the wall, in accordance with AS/NZS 5601 section 6. Wooden plugs shall not be used.

The top bracket has a keyhole slot so that the appliance can be positioned by hanging it on one screw. Once in position the appliance can be secured with appropriate fixings.

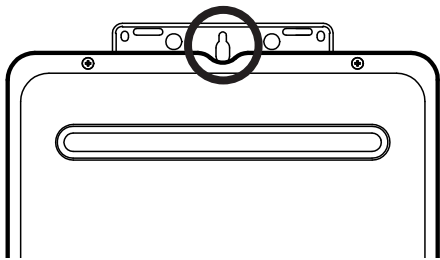

The appliance can be mounted directly against the wall or structure. There is no need to use non-combustible sheeting or leave an air gap between the appliance back panel and the wall or structure to meet the temperature hazard requirements of AS/NZS 5601.

## Pipe sizing

If the gas pipe sizing is insufficient the appliance won't perform properly. Gas pipe sizing must consider the gas input into this appliance as well as other gas appliances in the premises. The gas meter and regulator must be specified for this gas rate.

An approved sizing chart such as the one in AS/NZS 5601 should be used. Refer specification for gas consumption details.

Water pipe sizing and layout should be performed in accordance with AS/NZS 3500. All hot water pipe work should be insulated to optimise performance and energy efficiency.

## Water supply

The appliance is intended to be permanently connected to the water mains.

Refer specification for operational water pressure limitations. Approved pressure limiting valves may be required if the maximum rated water supply pressures are exceeded. To achieve the rated flow, the minimum water supply pressures must be met.

The water heaters will operate at lower pressures but will not achieve the rated flow. Contact Rinnai for gravity fed or low pressure installations.

Water chemistry and impurity limits are detailed in the operation guide within the warranty section. Most metropolitan water supplies fall within these requirements.

If you are unsure about the water quality contact your water authority. If sludge or foreign matter is present in the water supply, a suitable filter or strainer is required in the water supply to the water heater to prevent unwarranted damage and loss of performance.

## Frost protection

Frost protection operates automatically, as long as the appliance is connected to the electrical power supply, by activating when the temperature inside the unit drops below 3.5 °C<sup>1</sup>, and turns off once the temperature inside the unit reaches 7 °C<sup>1</sup>.

<sup>1</sup> Approximate temperatures

## Frost protection thermistor

The EF26 and A-Series models have an external thermistor to control frost protection. It is a small black indicator located on the bottom right hand side of the unit, directly underneath the cover screw (circled below). The frost protection thermistor needs to be exposed to the outside air to correctly function—do not insulate the frost protection circuit will not work correctly.

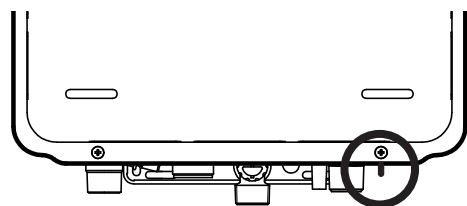

# Water delivery temperature

## Rinnai INFINITY units installed without controllers

**Diagram 1: Appliance set internally to 50 °C**

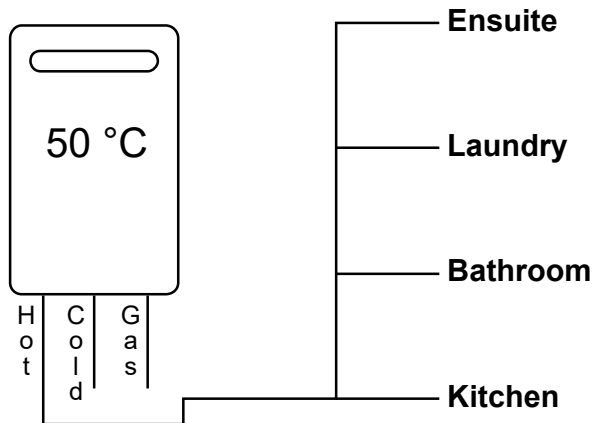

Minimum length of pipe from hot outlet to nearest sanitary fixture **for personal hygiene** - two metres.

**Diagram 2: Appliance set internally to greater than 50 °C**

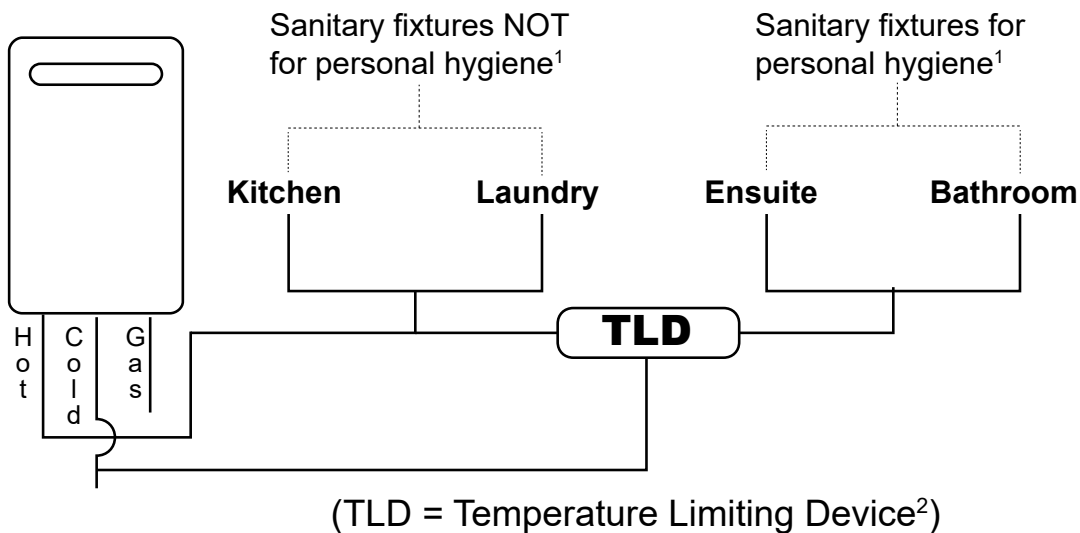

<sup>1</sup> Refer G12/AS1 6.14.1

<sup>2</sup> Refer G12/AS1 tables 8A and 8B for suitable valves for the application. For tempering valves of 8B ensure the manufacturer specifies them as suitable for use with continuous flow water heaters.

# Controller installation

The maximum number of controllers that can be fitted is **four**, refer water controller configurations section below.

## General information

Other manufacturers water controllers are NOT compatible with Rinnai water heaters. Water controllers MUST NOT be used with any solar boost water heater. Rinnai water controllers bought in from other countries are not compatible with Rinnai appliances sold in New Zealand.

Water controllers and transceivers (for those with wireless controllers) DO NOT contain serviceable parts and must only be serviced by an authorised person.

## Master controller

Only one master controller can be designated as a 'master' water controller. This water controller is normally used in the kitchen. The remaining controllers are 'sub-controllers' and are for use in bathrooms, toilets, and laundries. The temperature limit for all sub-controllers is 50 °C, this is a safety feature, to reduce the risk of burns in these areas. A master controller MUST NOT be installed in a bathroom.

## Water controller configurations

- A maximum of four Compact controllers (MC-601) can be fitted.
- Only one master controller can be installed. This can be a Kitchen Deluxe<sup>1</sup>, or any other Compact controller (MC-601).

<sup>1</sup> When a Kitchen Deluxe controller is fitted, it will always function as a master controller, this is the default setting and cannot be changed.

- In addition to a master controller, up to three additional controllers can be fitted

## Controller location

- Do not install water controllers near a heat source, such as a cook top, stove or oven. Heat steam, smoke, and hot oil may cause damage.
- Do not install water controllers outdoors unless protection from water/dust ingress and sunlight are provided.
- Do not install water controllers in direct sunlight.
- Do not install water controllers against a metal wall unless the wall is earthed in accordance with AS/NZS 3000.
- Water controllers must not be installed where chemicals such as benzene, alcohol, turpentine, hydrogen sulphide, ammonia, chlorine or other similar chemicals are in use.

The water controller is water resistant, however excessive exposure to water may result in damage. Durability is improved when positioned OUTSIDE the shower recess.

- Avoid direct exposure to water or steam as these may cause the controller to malfunction.
- Water controllers must be installed in shaded and clean locations. They should be fitted out of reach of children (suggested height 1.5 m from the floor), and installed at least 400 mm above the highest part of a sink, basin or bath.

When cleaning your water controller use only a damp cloth and mild detergent.

# EF26 condensate neutraliser tank and drain

The Rinnai INFINITY EF26 water heater generates condensate continuously at a rate of up to 5 litres per hour as a by-product of a highly efficient gas burner. This condensate has been neutralised by having an inbuilt condensate neutraliser kit.

## Important considerations for the neutraliser drain pipe

The content of AS/NZS 3500 'Temperature / Pressure Relief and Expansion Control Valve Drain Lines' has been used as a guide in preparing the information below.

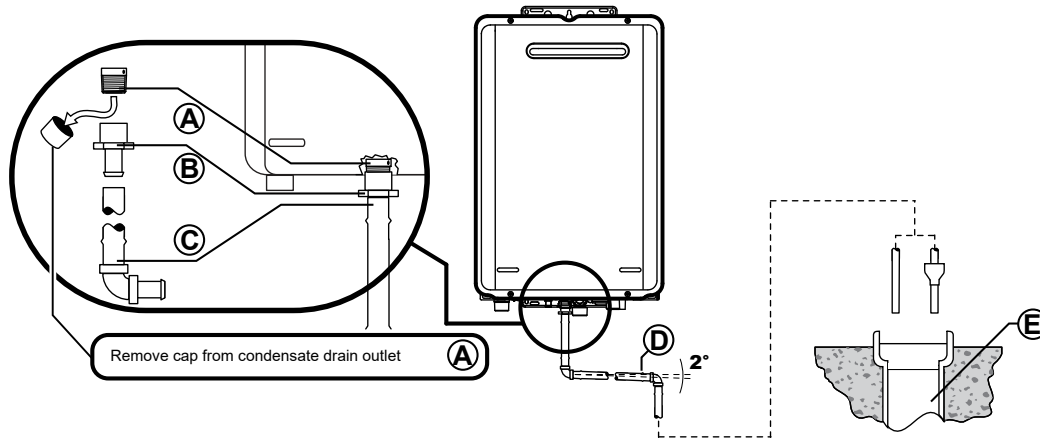

**A.** Water heater drain outlet connection, R $\frac{1}{2}$ " (15 mm) BSP male. Condensate / neutraliser drain outlet connection,  $\frac{1}{2}$ " (15 mm) BSP male nylon.

**N.B:** The black plastic shipping cap **MUST BE** removed from the condensate / neutraliser drain outlet prior to water heater operation.

**B.** PE R $\frac{1}{2}$ " BSP (15 mm) female to barbed irrigation system connector (13-19 mm) or equivalent plastic fitting<sup>1</sup>.

**C.** Drain pipe and fittings to match B.

**D.** Continuous fall of at least 2° from water heater to discharge point. Lengths and bends in accordance with the table below.

Lengths and changes of direction				
Max. length (m)	9	8	7	6
Max. changes of direction greater than 45°	3	4	5	6

**E.** Suitable points of discharge are deemed to be drains, sewers or pits. **DO NOT** discharge onto electrical connections, earth stakes, copper pipes, concrete paths or into a pond.

## Installation

The drain line **MUST NOT** discharge onto electrical connections, earth stakes, copper pipes, concrete paths or into a pond.

The point of discharge from each drain line shall be located so that the release of condensate / neutraliser does not cause a nuisance, is readily discernible and incurs no risk of damage to the building.

There shall be no tap, valve or other restrictions in any line.

Each line shall fall continuously from the valve to the approved point of discharge.

Drain lines shall not discharge into a storage water heater safe tray.

The end of the condensate line shall be:

- Not lower than 200 mm or higher than 300 mm above an unpaved surface; or
- Not lower than 75 mm, or higher than 300 mm above a gravel pit not less than 100 mm in diameter in a paved surface.
- Where discharging over a tundish or gully trap, drain lines shall have an air gap of a size at least twice the diameter of the drain line.

<sup>1</sup> Non-PE plastics will fail over time due to contact with the acidic condensate. Damage caused by installation of non-PE plastics will not be covered by warranty.

### **Interconnection of condensate drain lines**

Condensate / neutraliser drain lines from multiple water heaters may be joined together provided they conform with the requirements detailed on the previous page.

### **Common stack discharge**

Where individual water heaters are installed in a multi-storey building, the condensate / neutraliser drain lines may discharge into a common stack, subject to the following:

- The discharge from the common stack is to a tundish, having a discharge line, that is not less than the size of the common stack, directly connected to a fixture trap, and installed in connection with any adjacent soil or waste stack.
- The discharge point of the common stack is such that any discharge is readily visible and will not cause any nuisance.
- The common stack is vented by extending the pipe upwards, above the roof level.

### **Tundish drain lines**

The drain line from any tundish shall not be less than DN 20 or less than one size larger than that of the largest drain line discharging into a tundish. Tundish drain lines shall comply with the requirements detailed on the previous page.

### **Areas subject to freezing**

In areas where water pipes are prone to freezing, the drain pipe from any valve shall be insulated and not exceed 300 mm in length. It shall discharge into a tundish through an air gap of not less than 75 mm and not more than 150 mm measured from the outlet of the drain pipe to the rim of the tundish.

# Commissioning

AS/NZS 5601.1, clauses 2.6.8 and 6.11.2, states that every part of a gas installation shall be commissioned prior to initial use. It is the installer's responsibility to ensure all current AS/NZS 5601 requirements are met. The URL's provided are links to short videos on how key steps are performed.



The appliance operation must be tested after installation. Ensure the building occupants do not have access to the hot water outlets during this procedure.

## Please note

The Rinnai INFINITY EF26 and A-Series come with a factory preset outlet temperature of 50 °C. The high and low gas operating

pressures are also factory preset. Under normal conditions the operating pressures do not require adjustment during installation. Make adjustments **ONLY** if the unit is not operating correctly and all other possible causes for incorrect operation have been eliminated.

Inlet supply pressure to the appliance **MUST BE** checked and set within the operating parameters of the appliance in all instances.

If the appliance can not be adjusted to perform correctly call 0800 RINNAI (0800 746 624) for assistance.

## Commissioning steps

<b>1</b>	<b>Flush water pipes and gas line</b>	Before final connection of the water heater , flush the gas, hot and cold water supply lines. Swarf in the gas or water supplies may cause damage, a common problem, which is not covered by warranty.
<b>2</b>	<b>Connect the gas line</b>	
<b>3</b>	<b>Purge the gas line of air</b>	
<b>4</b>	<b>Final connection test</b>	
<b>5</b>	<b>Check supply pressure</b>	Operate ALL other gas appliances at their maximum rate. With all gas appliances on maximum the supply pressure must read between 1.13-3.0 kPa on Natural gas and on LPG 2.75-3.0 kPa.  If the pressure is lower, the gas supply is inadequate and the appliance will not operated to specification. It is the installer's responsibility to check the gas meter, service regulator and pipe work for correct operation and sizing, and rectify as required.
<b>6</b>	<b>PCB settings checked</b>	Refer sideways flue diverter information on the next page and the PCB interface layout and functions page.  PCB settings checked if the factory default temperature has been changed.  Dip switch settings checked if a sideways flue diverter is fitted.
<b>7</b>	<b>Operate and test for gas leaks</b>	Replace the appliance front cover otherwise the unit won't operate correctly, and operate and test for gas leaks using an electronic leak detector.
<b>8</b>	<b>Operational test</b>	Confirm the water flow and hot water delivery temperature using a thermometer.  If water controllers are fitted, it is necessary to test their operation through the complete range of functions, refer separate instructions provided with the water controllers.

**9 Check cold water inlet filter**

Inspect and clean the water inlet filter. This may need to be repeated to ensure the filter remains clear, especially on new installations.

If you feel the customer is capable of doing this check it would be beneficial to show them how to inspect and clean the water filter as well.

**10 Customer handover**

After testing is completed, explain to the customer the function and operation of the water heater and water controllers (if fitted).

Also talk to them about:

- The gas, power, and water connections
- How frost protection works
- Procedure for draining the water heater
- Where to find the data plate
- Maintenance and servicing

If the customer is not there try and contact them by phone to discuss these important points.

Ensure the installer details section is completed in the operation guide, the commissioning checklist has been completed and signed, and that the guide and checklist are left with the customer.

## Sideways flue diverter dip switch changes

When delivered ex-factory, by default SW1, SW2, SW3, and SW4 of the DipSW are set to the OFF position.

If a sideways flue diverter is installed onto the water heater, SW1 and SW3 of the DipSW must be set to the ON position.

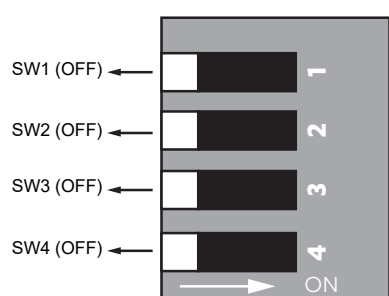

Default dip switch settings as they are ex-factory.

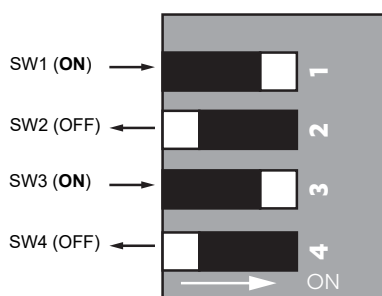

Dip switch settings required for a sideways flue diverter installation.

The dip switch change for a sideways flue diverter is required to increase the combustion fan speed, which helps overcome the friction losses from having a sideways flue diverter installed on the water heater.

# PCB interface and dip switch settings

The PCB interface and dip switch settings must only be changed by a licensed gasfitter. They have been provided as there may be a requirement to change the temperature of the water delivered from the water heater or change the dip switch settings if fitting a sideways flue diverter.



Care must be taken when changing the temperature or dip switch settings as they can be easily switched or bumped into the wrong position. Fully check the operation of the water heater before leaving including the temperature of the water delivered.

The cover of the water heater will need to be removed to carry out this operation. As this will expose live mains voltage wiring **please disconnect the power supply before removing the front cover.**

We wish to draw your attention to the requirements of the New Zealand Building Code and compliance document G12/AS1. This requires that water delivered to sanitary fixtures be no more than 50 °C. Increasing the water heater set temperature will require that you protect all sanitary fixtures to which the appliance is plumbed with suitable tempering valves or something similar.

Rinnai will accept no liability for issues arising out of the use of this information.

If you have any doubts about the performance of the water heater, please contact Rinnai by phoning 0800 RINNAI (0800 746 624).

The following information details settings for the Rinnai INFINITY EF26 and A-Series models only. They are not applicable for other models.

## Basic operation of the PCB interface

- To place the PCB into programming mode press PB2 until the LED digital display shows 1, noting that the current set value will be displayed shortly afterwards.
- To alter a value press PB4, each press of the button will select the next available value.
- To change to another menu, press PB3, each press of the button will select the next available menu.
- To exit the programming mode and save the selected settings press PB2 until the LED display goes blank.

## Note:

- If no buttons are pressed the PCB will automatically exit programming mode after 10 mins.
- Exiting programming mode sets the value last viewed as the current value.

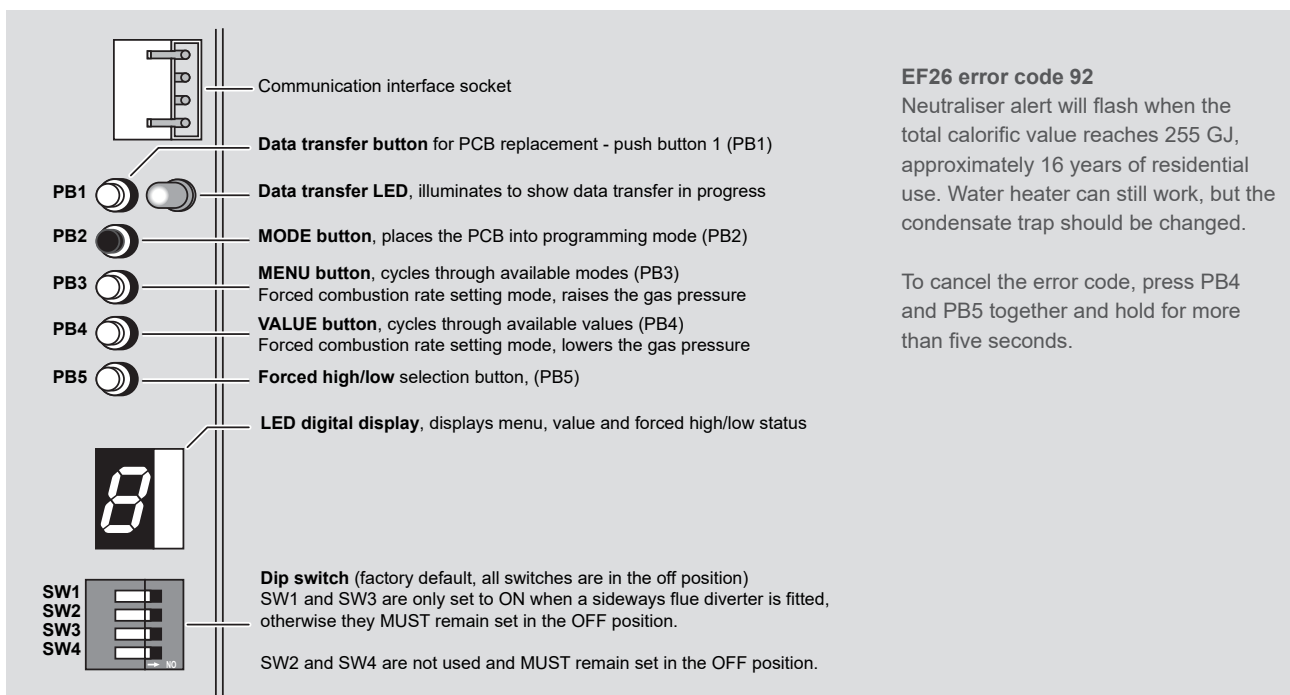

Menu	Menu description	Value							
		A	b	C	d	E	F	H	J
1	Gas type	ULPG	NG	N/A	N/A	N/A	N/A	N/A	N/A
2	Model	2626	2426	2024	1620	N/A	N/A	N/A	N/A
3	Fixed / Max. temp	55 °C	65 °C	60 °C	50 °C	42 °C	40 °C	N/A	N/A
4	OFF water flow rate	+ 3 °C	+ 6 °C	N/A	N/A	N/A	N/A	N/A	N/A
5	50 °C delivery adjustment temp.	Tset-2 °C	Tset+0 °C	Tset+1 °C	Tset+2 °C	Tset+3 °C	Tset+4 °C	N/A	N/A
6	Remote controller safe program	ON	OFF	N/A	N/A	N/A	N/A	N/A	N/A
7	OHS	No	Yes	N/A	N/A	N/A	N/A	N/A	N/A
8	<b>EF26 only</b> Condensation prevention on manifold	Default							
9	<b>A24/A26 only</b> Fan revolution	180 Hz	100 Hz	Setting change to reduce fan noise if customer states unit is too noisy (Ver. 7, PCB label G)					
0	Post fan time	65 sec	120 sec	240 sec	480 sec	To reduce the HEX temp. after combustion			

If the settings are changed, please note these on this sheet for future reference. These will be needed if a PCB replacement is required and a manual data transfer is needed.

 Dark shaded sections = default setting

#### Parameter setting notes

- 2: Values in Menu 2 cannot be adjusted.
- 4: Menu 4 OFF water flow rate  
The temperature of the outgoing hot water is monitored by a built-in sensor. If the temperature of the outgoing hot water rises more than 3 °C (default, or 6 °C if 4b) above the selected temperature shown on the digital monitor or the preset limit when water controllers are fitted, the burner will automatically go out.
- 6: Menu 6 Remote controller safe program  
Factory default is ON. If a controller has been continuously connected for more than six hours, the PCB automatically defaults to controller only mode, making the assumption that the water heater will always be connected to and operated by a controller. This means if a controller is disconnected, the inbuilt safe program will only allow the unit to deliver a maximum temperature of 42 °C. If this safe program is not needed, change menu 6 from A (ON) to b (OFF).
- 7: OHS for solar applications  
N/A for New Zealand models, this is for Australian models only that have different temperature settings. Please remember that the A-Series and the EF26 are not suitable and will not be warranted for solar applications.
- 8: Prevention of condensation on the manifold (EF26 only)  
If exhaust gases go back into the combustion chamber, condensation on the manifold nozzle causes error 11. To prevent this, the post-fan time (fan revolution after combustion) can be controlled as follows.

8	Prevention of condensation on the manifold	A	b	C	d
	Post fan time	Outside temp. > 15 °C → 15 sec. Outside temp. ≤ 15 °C → 120 sec.	15 sec	240 sec	480 sec
	Post fan revolution	X (Hz), X depends on the model, e.g. 180 Hz	X (Hz)	X(Hz) + 50 Hz	X(Hz) + 50 Hz

# A-Series controller communication cables

Wired water controllers operate at an extra low voltage (12 V DC) which is supplied from the water heater, a 10 m long communication cable is supplied for connection to the water heater. Only Rinnai supplied communication cables may be used.

The water heater end of the cables is fitted with spade terminals. Only two pairs of cables (four spade connectors in total) may be terminated. When attaching three or four cables it is necessary to join the cable terminators as shown below.

For each pair cut off the existing spade connectors and re-terminate each pair into a new spade connector (A). Spade connectors are available from your local electrical component retailer

Single cables can be used when terminating up to two communication cables.

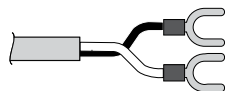

Paired cables are to be used when terminating three or four communication cables.

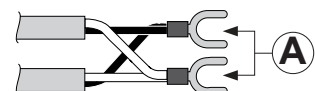

## Connecting one or two communication cables

Follow steps one through five below to terminate the cables to the water heater.

## Connecting three or four communication cables

To connect three or four cables, separate all the cables to be fitted into pairs.

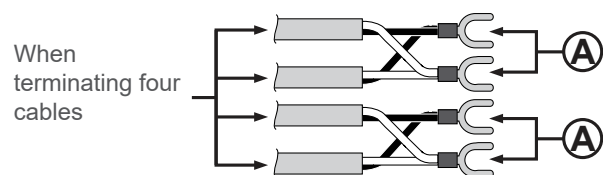
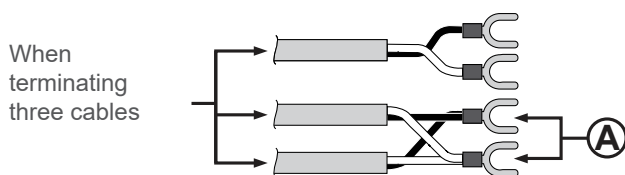

Follow steps one through five below to terminate the joined cable pairs to the water heater.

1. Isolate the power supply by switching the power point off and removing the power plug of the water heater from the electric power socket.
2. Removing the retaining screw of the cable connector at the base of the unit.
3. Swing the cable connector door open and thread the cable through the weather seal of the cable access hole, allowing sufficient cable length so that the sheath of the cable can be secured with the cable clamp supplied with the transceiver.
4. Loosen the screw terminals and connect the cable spade connectors to these terminals and re-tighten.

Polarity is not important, either wire colour can be connected to either terminal.

5. Return the cable connector to the original position, taking care not to damage the cable wires in the process, and replace the retaining screw.

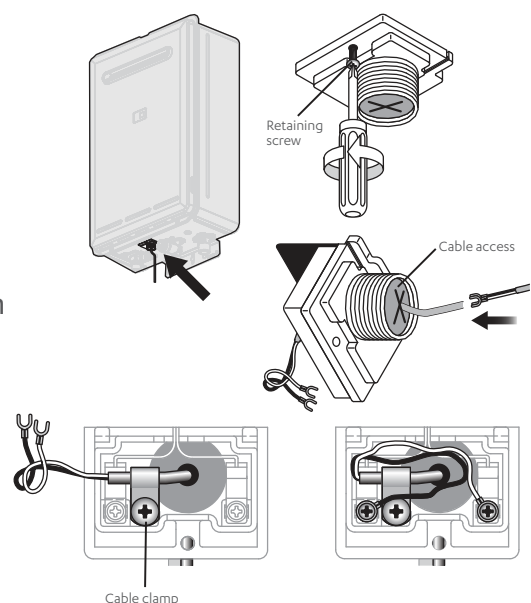

# EF26 controller communication cables

Wired water controllers operate at an extra low voltage (12 V DC), which is supplied from the water heater. A 10 m long communication cable is supplied for connection to the water heater. Only Rinnai supplied communication cables may be used.



## Connecting communication cables to the mini-plug

DO NOT attempt to connect water controller cables to the mini-plug when it is plugged into the PCB unless the power to the water heater is switched OFF, otherwise damage to electrical components may occur.

Water controllers are connected to the PCB by a dedicated pre-wired mini-plug.

Standard electrical cable connectors can be used to terminate the water controller wires to those on the mini-plug. The existing spade connectors, of the communication cables, will need to be removed prior to termination. Controllers are not polarity sensitive, however to avoid confusion it is recommended that like coloured wires be terminated together.

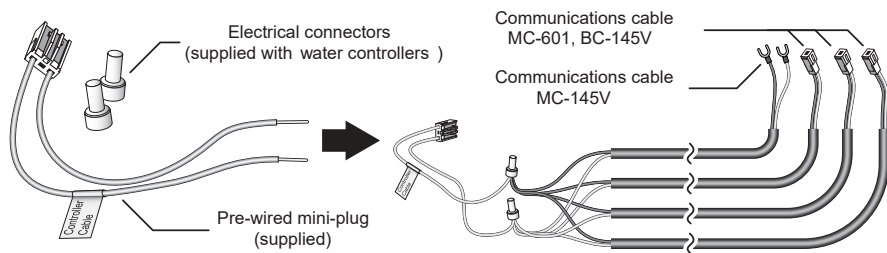

## Connecting communication cables to the PCB (refer image below)

DO NOT attempt to connect the mini-plug or water controller cables to the water heater unless the power to the water heater is switched OFF, otherwise damage to electrical components may occur.

1. Isolate the power supply by switching the power point off and removing the water heater plug from the power socket.
2. Remove the front cover of the appliance.
3. Insert the mini-plug and the connected water controller cables through the cable access at the base of the appliance. Ensure the cable connectors are located inside the appliance for protection.
4. Locate the PCB (bottom right of the appliance), and carefully move the plastic safety cover out of the way.
5. Locate the accessory port socket (bottom front of PCB).
6. Plug the mini-plug into the accessory port socket, the plug and socket are keyed so that they can only be plugged into the one direction).

7. Proceed with the water controller installation and connect the communication cables to the controllers.

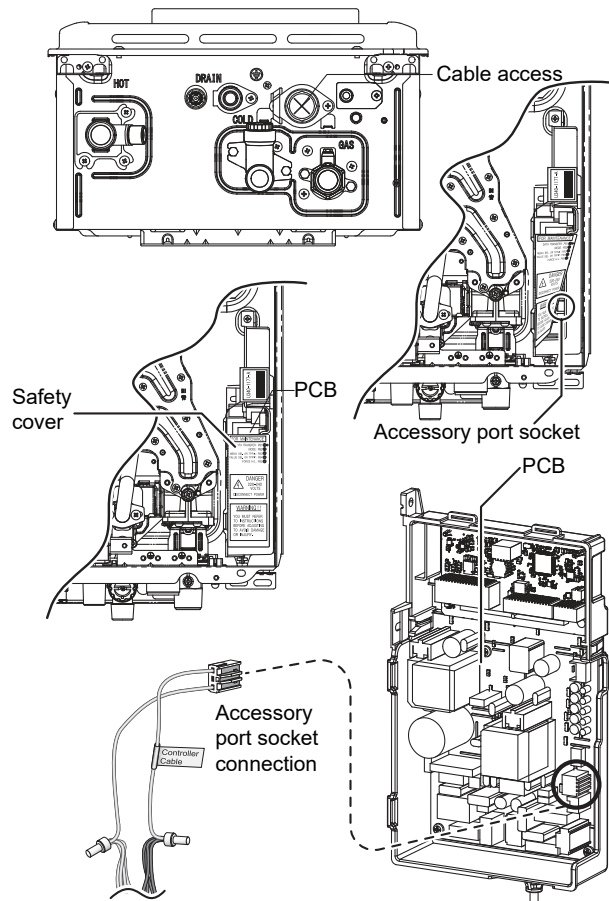

**Rinnai.co.nz**

Tel: 0800 746 624  
<http://www.youtube.com/rinnainz>  
<http://facebook.com/rinnainz>

Installation guide

U340-1336X02(01)  
REU-A/E(NZ)